

## ENERGYPLUS MODEL-BASED PREDICTIVE CONTROL (EPMPC) BY USING MATLAB/SIMULINK AND MLE+

Jie Zhao<sup>1</sup>, Khee Poh Lam<sup>1</sup>, B. Erik Ydstie<sup>2</sup>

<sup>1</sup>Center for Building Performance and Diagnostics, School of Architecture

<sup>2</sup>Department of Chemical Engineering, College of Engineering  
Carnegie Mellon University, Pittsburgh, Pennsylvania, USA 15213

### ABSTRACT

Current model-based building control research often uses first-principle or linear identification based building and system model. The detailed high-order EnergyPlus model has rarely been used due to the data interoperability issue and its “black-box” properties. This paper proposes an EnergyPlus Model-based Predictive Control (EPMPC) system to control the under floor air distribution system in a multi-zone open office. The exhaustive search optimization algorithm is utilized in the Matlab/Simulink environment via MLE+ co-simulation tool. Comparing to the baseline control system, by using EPMPC, the HVAC energy consumption can be reduced by 18.9% while maintaining the occupant Predicted Mean Vote (PMV).

### INTRODUCTION

Research shows more than 90% of office building’s life-cycle energy is operating energy (Cole and Kernan 1996). In the US, about 40% of the office building’s operating energy is consumed by heating, ventilation, and air conditioning (HVAC). Control strategy is a major factor that influences building HVAC operating energy usage.

Over the past 2-3 decades, there are numerous studies on model-based (or simulation-based) building control theories and applications, thanks to the new development of control technology and simulation tools. Particularly, the research on Model Predictive Control (MPC) (Garcia, Prett and Morari 1989) is a key focus.

Among the MPC studies, first principle-based linear models are widely used. The early studies focused on controlling HVAC system at the component level. (Wang and Jin 2000) developed an adaptive MPC controller for variable air volume (VAV) system. Simplified first principle-based models of the single-zone building and VAV system components were created. Similarly, (Yuan and Ronald 2006), (Dong 2010) (Moon and Kim 2010), (Morosan, et al. 2010), (Gyalistras 2010), (Castilla, et al. 2011), (Daum, Haldi and Morel 2011), (Hazyuk, Ghiaus and

Penhouet 2012) (Sturzenegger, et al. 2012) have developed MPC systems to control various building systems to minimize energy consumption and maintain indoor setpoint using first principle-based models.

Several MPC studies used linear identified models to optimize the building and system “black-box” model, including (Freire, et al. 2008) (Kolokotsa, et al. 2009) (Paris, et al. 2010) and (Privara, et al. 2011). The real-time experimental and/or simulation data were collected to identify the linear model parameters.

Most of the studies above suggest that MPC is an effective method to improve building system performance. However, several practical problems of the two model types are seldom discussed. (1) First principle-based models are suitable for single zone and simple geometry buildings, but are difficult to be applied to real buildings, which typically have multiple zones and irregular geometric shapes. (2) The linear identified models often require plenty of sensor data both at the system component level and in the indoor environment, which can have high temporal and financial cost. (3) Developing the two models requires high-level mathematical skills, which may not be a viable solution for daily building operation.

Building energy modeling tools can provide a feasible solution for the MPC research. For instance, EnergyPlus is a well-developed, validated, and constantly updated tool. It has high-order detailed building geometry and system modeling capability. Throughout the building life-cycle, if the system is changed, it is much easier for practitioners to update the EnergyPlus model than to update a first principle-based or linear identified model. However, currently, two difficulties of using EnergyPlus model prevent it to be widely utilized in the MPC research. First, data interoperability and time synchronization between EnergyPlus and other control system development tools can be an issue. Second, the “black-box” model optimization can be challenging to implement.

The difficulties might be the reasons why current MPC studies using simulation tools use simplified linear system models for optimization purpose at the same time. (Yahiaoui, et al. 2006) proposed a MPC

controller using ESP-r model to produce plant model. The simplified system model and control laws were implemented in Matlab/Simulink. (May-Ostendorp, et al. 2011) developed an MPC control system that was built in the Matlab environment and connected to EnergyPlus by writing and reading the text file. The control rules were generated by optimizing the window opening schedules to save energy. (Bernal, et al. 2012) introduced a control system that can link EnergyPlus model with Matlab/Simulink environment via MLE+. The first principle-based system model was optimized in Matlab/Simulink environment and the control performance was simulated in EnergyPlus.

Other existing model-based MPC studies using simulation tools combined other optimization tools to solve “black-box” optimization. The MPC system proposed by (Coffey, et al. 2010) and (Kummert, et al. 2011) utilized TRNSYS for plant modeling and GenOpt for optimization.

In this paper, an EnergyPlus model based predictive control system (EPMPC) is developed without using the simplified system model and the optimization tool. The EnergyPlus model is directly co-simulated and optimized with the control law in the Matlab/Simulink environment via MLE+. The exhaustive search algorithm is implemented in Matlab as the black-box optimization method. An air handler unit (AHU) of the under floor air distribution (UFAD) system is controlled in a multi-zone open office space. The system is simulated in two weeks using TMY3 weather file. A baseline logic control system is simulated with the same assumptions. The energy and multi-zone average predicted mean vote (PMV) of the two systems are compared. The result suggests that the EPMPC can reduce HVAC energy consumption by 18.9% while maintaining the occupant PMV within the (-0.5, +0.5) range.

## METHOD

### Building and systems modeling

A newly constructed two stories office building - Center for Sustainable Landscapes - in the city of Pittsburgh, Pennsylvania USA is modeled. The building is equipped with a central AHU with ground source heat pump as the cooling and heating source. The UFAD is used for the open office, conference rooms and other occupied spaces. The ceiling-based air distribution system is used for service spaces, such as restrooms, mechanical rooms, and storage rooms.

The ASHRAE 90.1-2007 baseline and design phase whole building models are created using DesignBuilder and EnergyPlus program under the “Design-Build-Operate Energy Information Modeling (DBO-EIM)” infrastructure (Zhao, et al. 2012). The key of the DBO-EIM infrastructure is to use the detailed design phase energy model throughout the entire building life cycle by validating

and adapting model assumptions during construction, commissioning and operation periods. Therefore, the model is expected to be “accurate” and easy-to-use for model-based building control systems in the daily operation to optimize energy and comfort. In this paper, the design phase model is applied in both the baseline and the EPMPC control. Figure 1 (a) and (b) illustrate the whole building and the first floor model view in the DesignBuilder program, respectively.

The design phase model result indicates that comparing to the ASHRAE 90.1-2007 baseline, cooling and heating peak load is reduced by 53.9%, and annual energy consumption is reduced by 39.8%. The annual energy use intensity (EUI) of the design case model is 86.0kWh/m<sup>2</sup>. More information on the modeling assumptions and results can be found in (Zhao, et al. 2012). One can conclude that the design case HVAC system is efficient with normal operation schedules. So it is worthwhile to explore advanced control strategies for this efficient system to further reduce the HVAC operation energy.

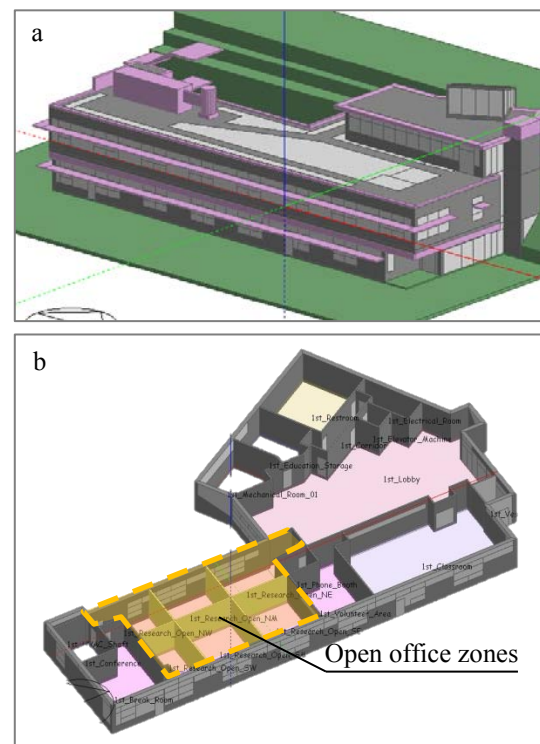

Figure 1 Model view in the DesignBuilder program (a. whole building view, b. 1st floor zoning view)

Figure 2 shows the model’s HVAC diagram, as well as the control and sensing points. Four types of control and sensing points are shown on the diagram. “AT” represents the air temperature control points with control laws implemented in Matlab. “RH” is controlled by the relative humidity setpoint of the desiccant dehumidification system in EnergyPlus, which is < 50% for occupied hours. “FR” represents the air flow rate of the outdoor air, the return air (and its bypass), and the supply air, which are controlled in the EnergyPlus based on the temperature setpoints

“AT”. “1/0” represents the binary control signal for the availability of the cooling and heating coils. “ZH” and “RT” represent the relative humidity and radiant temperature measurements in each different open office zone, as shown in Figure 1 (b). All the points shown on the diagram are measured in EnergyPlus using system node output function.

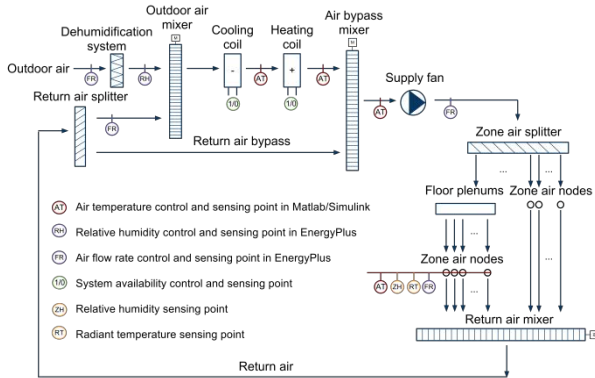

Figure 2 HVAC diagram and control/sensing points

### Baseline control

The goal of the baseline control is to set up a framework using Matlab/Simulink and EnergyPlus co-simulation to perform multi-zone PMV control and obtain the energy and thermal comfort performance of the logic control system. The MLE+ (version 1) is used as the data exchanger between Matlab/Simulink and EnergyPlus (Nghiem 2012).

Table 1

Assumptions for the baseline and EPMPC controls

		BASELINE	EPMPC
Zone control	Weekdays 7:00-20:00	PMV control: [-0.5, 0.5] Temperature control: [22, 24] °C	
	Weekends & weekdays 20:00-7:00	PMV control: [-2, 2] Temperature control: [18, 28] °C	
Comfort assumptions		met = 1.0, air speed = 0.137 m/s summer clo = 0.7, winter clo = 1.0	
Weather and schedules		TMY3, design case occupancy, lighting, and equipment schedules	.csv files with the same information as the Baseline's

As shown in Figure 1 (b), the 6 open office zones are the PMV control spaces. Other zones are controlled by conventional temperature setpoints. Table 1 lists the setpoints, comfort, weather and schedule assumptions.

Figure 3 shows the baseline control implementation schema. Two-loop cascade control is implemented in the co-simulation environment. At the central level, the AHU setpoint is controlled by both outdoor air temperature and average zone PMV feedback. At the zone level, air flow rate is controlled by adjusting

floor-based diffuser's damper position in EnergyPlus by the temperature setpoint calculated in Matlab/Simulink. Each zone can have different temperature setpoints based on its PMV. The air temperature, relative humidity and radiant temperature are calculated in EnergyPlus at each step.

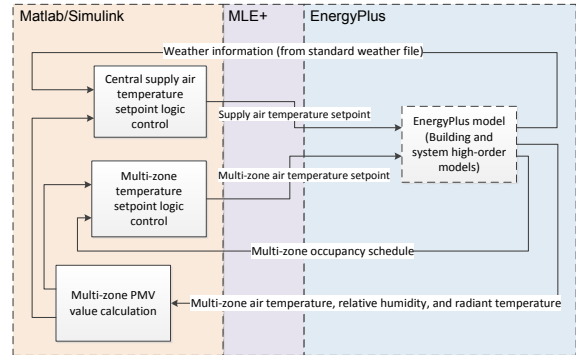

Figure 3 Baseline control implementation schema

### EPMPC problem description

The objective of the EPMPC is to maintain the same comfort criteria as the baseline and to minimize the HVAC energy consumption by optimizing the AHU supply air temperature. The objective function can be described as,

$$\min_x m \text{ in } c(x,t) \quad h(x,t) \quad f(x,t) \quad p(x,t) \quad (1)$$

subject to,

$$|MV| \begin{cases} 0, & f_{occ}(t) = 0 \\ , & \text{otherwise} \end{cases} \quad (2)$$

$$T_c(t) \in (14, 18) \quad (3)$$

$$T_h(t) \in (24, 32) \quad (4)$$

$$A_H * A_C = 0 \quad (5)$$

$$T_s(t) \in \begin{cases} (14, 20), & A_C = 1 \\ (24, 32), & A_C = 0 \end{cases} \quad (6)$$

$$t_{mode}(t) \geq 3600 \quad (7)$$

where,

$t$ , time (s);

$x$ , the optimized supply air temperature setpoint, (°C);

$J(t)$ , total HVAC system power at time  $t$ , (kW)

$Q_c(t)$ , power of the cooling system at time  $t$ , (kW);

$Q_h(t)$ , power of the heating system at time  $t$ , (kW);

$Q_f(t)$ , power of the supply air fan at time  $t$ , (kW);

$Q_p(t)$ , power of the water pumps at time  $t$ , (kW);

$f_{occ}(t)$ , occupancy status at time  $t$ , (kW);

$T_c(t)$ , cooling coil air outlet temperature setpoint at time  $t$ , (°C);

$T_h(t)$ , heating coil air outlet temperature setpoint at time  $t$ , (°C);

$A_H$ , availability of heating coil, (0, 1);

$A_C$ , availability of cooling coil, (0, 1);

$t_{mode}(t)$ , cooling/heating mode length at time  $t$ , (s).

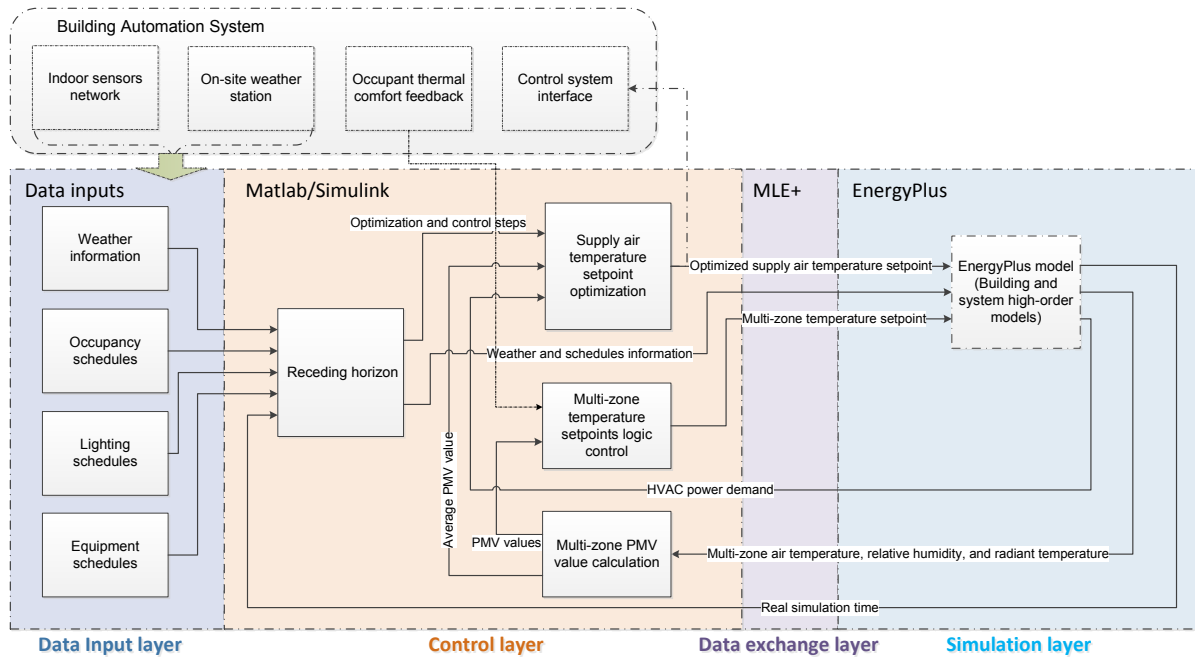

Figure 4 EPMPC control implementation schema

**EPMPC optimization**

The exhaustive search algorithm (or Brute-force algorithm) is chosen to solve the problem. First it is a “test-and-generate” algorithm, which works for the “black-box” simulation-based optimization (Kolda, et al. 2003). Second, the algorithm is suitable for the problem that has “reasonable” computation time (Sinha 2008). The EPMPC optimization problem has multiple constraints which results in a comparatively small search space. For example, in cooling mode, the search space for the cooling coil is from 14 to 18 °C. And for practical reasons, 0.5°C difference is a reasonable discrete interval. Therefore, the number of search steps is 9 for hourly control. And the optimization simulation period is 24 hours in accordance with the EnergyPlus run time. The exhaustive search time is feasible for real-time simulation.

Equations of (3-7) indicate the optimization problem has binary parameters, which needs to be separated into two modes: cooling mode and heating mode. The threshold is outdoor dry bulb temperature.

The constraints are handled by equation (8) to guarantee the thermal comfort performance is prioritized when the constraints are not met.

$$\begin{cases} J = \min(f_{\text{power}}(x, t)), & \text{if Eq.(2) is satisfied} \\ J = \min(|f_{\text{PMV}}(x, t)|), & \text{otherwise} \end{cases} \quad (8)$$

**EPMPC implementation**

Figure 4 shows the EPMPC control implementation schema. In the data input layer, weather, occupancy, lighting, and equipment information is contained in independent .csv files. The data is sent to the “receding horizon” module in Matlab and then to Energy Plus using the “External Interface - Actuator”

function to override the original configuration in the EnergyPlus model (Pang, et al. 2011).

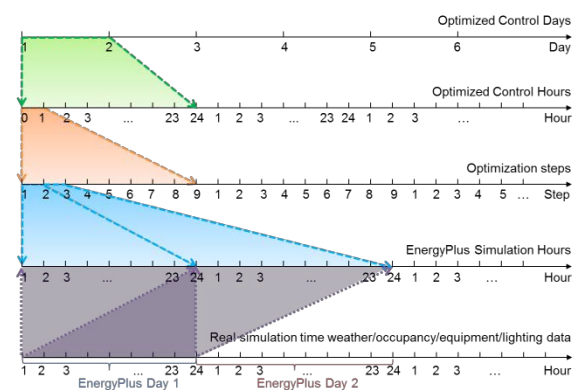

Figure 5 EPMPC receding horizon mechanism

It is essential and beneficial to override the weather and schedule data. First, the EPMPC needs to perform optimization in EnergyPlus, which will use the same day weather and schedule information multiple times to calculate one control step. Figure 5 illustrates the concept of “receding horizon” for EPMPC. For each control hour of a real day, multiple steps of simulation need to be completed using the same weather and schedule information but in different EnergyPlus simulation days. At the end of each simulation cycle, the optimization algorithm searches for the optimized control setpoint and potentially can send them to the building automation system (BAS) interface to perform real control in the building, as illustrated in Figure 4. The BAS modules are introduced but not implemented in this paper.

Second, using separate data inputs to override the weather and schedule information can facilitate the real-time control in real building operation. The data

files in “csv” or “dat” format can be easily updated with real-time information by linking with indoor sensors network and on-site weather station via the BAS, as shown in Figure 4.

The “supply air temperature setpoint optimization” module can calculate the optimized supply air temperature setpoint at each control step. The “multi-zone temperature setpoint logic control” and “multi-zone MV value calculation” modules are the same as the ones in the baseline control.

The “data exchange layer” performs data communication and time synchronization functions. In the “simulation layer”, the inputs of the EnergyPlus model are AHU yet-to-be-optimized setpoints, weather and schedule information, and multi-zone setpoints. The outputs are the HVAC power, multi-zone air temperature, relative humidity, and radiant temperature, as well as the real simulation time to be used in the “control layer”.

## RESULTS AND DISCUSSION

### Winter results

Figure 6 shows the supply air temperature, outdoor air temperature, and supply air mass flow rate of the baseline and the EPMPC in one typical winter week. The EPMPC can maintain an average lower supply air temperature and supply air mass flow rate than the baseline in the heating mode before 9am 01/12 and a higher supply air temperature in the cooling mode after 9am 01/12. It is common that in winter, due to occupancy, equipment, and other internal loads, the office building’s cooling load can exceed its heating load when the outdoor temperature rises.

Figure 7 illustrates the EPMPC HVAC power comparison between the baseline and EPMPC. Due to a lower heating supply air temperature, a higher cooling supply air temperature, and lower fan speed, the energy consumption reduction is 28.9%, as shown in Table 2. The energy saving is calculated by using TMY3 typical winter weather file.

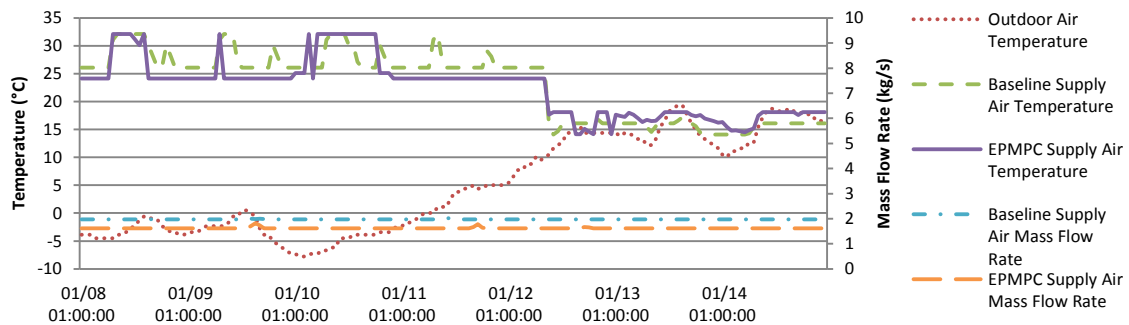

Figure 6 outdoor temperature and control variables of the baseline and EPMPC results in winter

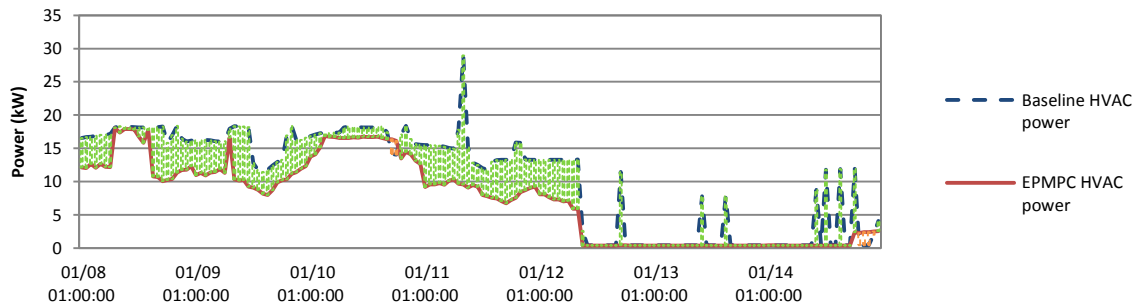

Figure 7 energy performance of the baseline and EPMPC results in winter

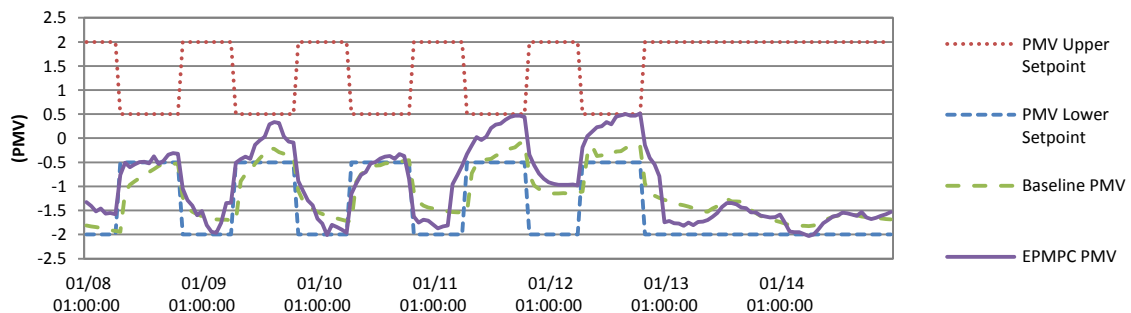

Figure 8 thermal comfort performance of the baseline and results EPMPC in winter



Table 2

One week HVAC energy consumption comparison

	Baseline energy (kWh)	EPMPC energy (kWh)	Energy savings
1 week simulation in winter	1784.8	1268.7	28.9%
1 week simulation in summer	1154.8	1123.8	2.7%
Total	2949.6	2391.5	18.9%

Figure 8 shows the average zone PMV comparison. In the first 3.5 heating days, the PMV is close to the lower setpoint, and in the last 2 occupied cooling days, the PMV is close to the upper setpoint. The EPMPC pushes the PMV close to the setpoint boundary to minimize energy.

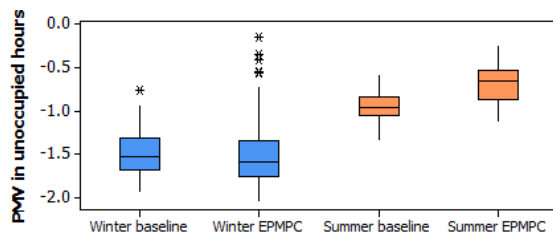

Figure 9 PMV distribution in unoccupied hours

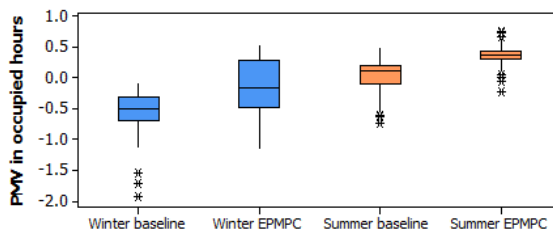

Figure 10 PMV distribution in occupied hours

In Figure 9, the winter median PMV in unoccupied hours is -1.60 (with a lower quartile of -1.76 and an upper quartile of -1.35) for the EPMPC, and -1.54 (with a lower quartile of -1.68 and an upper quartile of -1.32) for the baseline, respectively. The EPMPC makes majority of the unoccupied PMV lower than the baseline but still within the setpoint range.

In Figure 10, the winter median PMV in occupied hours is -0.15 (with a lower quartile of -0.48 and an upper quartile of 0.29) for the EPMPC, and -1.54 (with a lower quartile of -0.69 and an upper quartile of -0.32) for the baseline, respectively. And the PMV of the EPMPC has fewer low value outliers. Figure 10 implies the EPMPC has better ability to maintain PMV setpoints in winter occupied hours.

### Summer results

Supply air temperature, outdoor air temperature, and supply air mass flow rate of the baseline and the EPMPC are shown in Figure 11. Unlike the baseline, the EPMPC varies the supply air temperature setpoint more often. And in general, the supply air flow rate of the EPMPC is lower than that of the baseline, which implies the energy consumption decrease in the supply fan power.

Figure 12 shows the hourly power consumption profile of the two systems. Although it is difficult to see a general pattern of energy savings from the graph, the cumulative energy savings during one summer week is 2.7% as shown in Table 2.

The PMV value of the two systems is shown in Figure 13. Similar to the winter results, the PMV value is pushed towards the upper boundary during both the occupied and unoccupied hours. Figure 9 and 10 give a clearer picture on the PMV distribution. In the unoccupied hours, the EPMPC median PMV is -0.66 (with a lower quartile of -0.87 and an upper quartile of -0.54); the baseline median PMV is -0.97 (with a lower quartile of -1.05 and an upper quartile of -0.84). Similarly, in the occupied hours, the EPMPC median PMV is 0.37 (with a lower quartile of 0.30 and an upper quartile of 0.44); the baseline median PMV is 0.11 (with a lower quartile of -0.10 and an upper quartile of 0.20). The EPMPC has higher average PMV for energy saving purpose.

### Discussion

The results suggest that the EPMPC can reduce the HVAC energy consumption and maintain the occupant thermal comfort within (-0.5 +0.5) PMV range. However, potentially, EPMPC can be improved in the following aspects:

First, the optimization in the EPMPC is performed based on 1 hour control step, and the simulation is performed in 24 hours. It is expected that the energy and thermal comfort performance can be better if multiple control steps are optimized at each time step. The undershoot on 01/10 in Figure 8 and overshoot on 07/11 in Figure 13 might be avoided when the optimization horizon is longer. However, this further development will increase the computation time significantly.

Second, the model used in the baseline and EPMPC is the design stage model of the DBO-EIM schema. The occupancy, lighting and equipment schedules have not been calibrated. The model will be further validated when the building is in normal operation.

Third, the real occupant behavior has not been considered yet. Future work will focus on combining occupant presence model and occupant thermal comfort feedback data into the EPMPC.

Forth, passive strategies have not been considered in this study. Natural ventilation can be modeled in EPMPC and potential energy savings can be expected during mild weather conditions.

### CONCLUSION

An EnergyPlus Model based Predictive Control system is developed by using Matlab/Simulink and MLE+ co-simulation tool. In two weeks of winter and summer simulation using TMY3 weather file, comparing to the baseline logic control, which is also implemented using the same co-simulation method, the EPMPC can save HVAC operation energy by

18.9%. The occupant PMV value is as good as the baseline if not better.

The benefits of using the EnergyPlus model over the simplified first principle or identified linear model include: (1) it can model complex buildings and

systems; (2) it can be continuously updated with little cost and effort; (3) it requires less mathematics skills to manage in daily operation once the system has been developed.

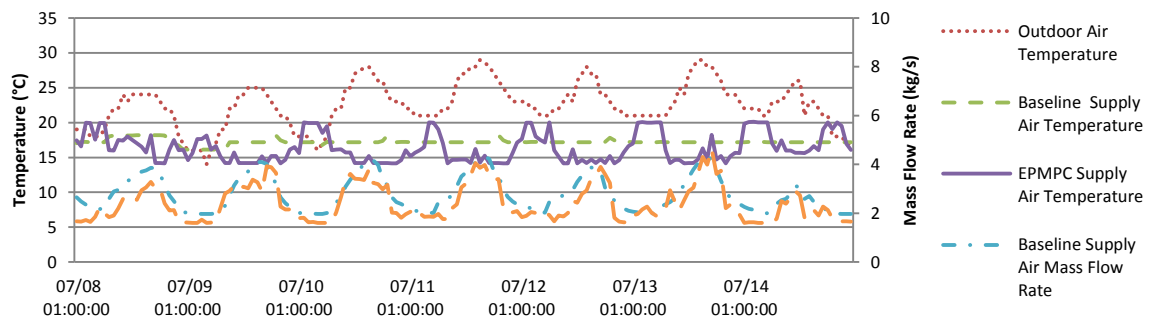

Figure 11 outdoor temperature and control variables of the baseline and EP MPC in summer

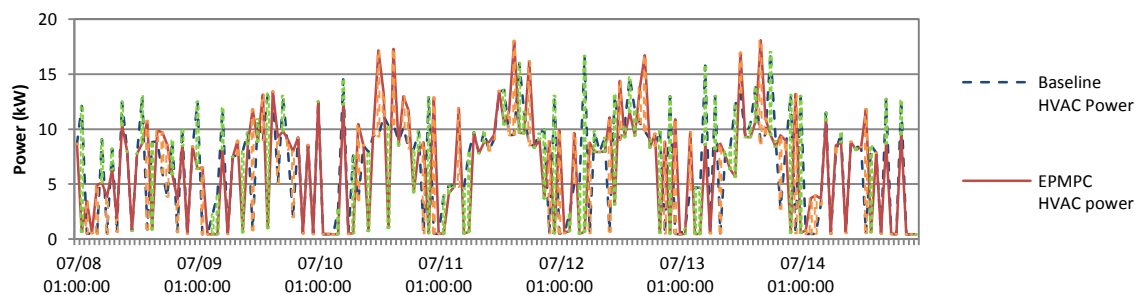

Figure 12 energy performance of the baseline and EP MPC in summer

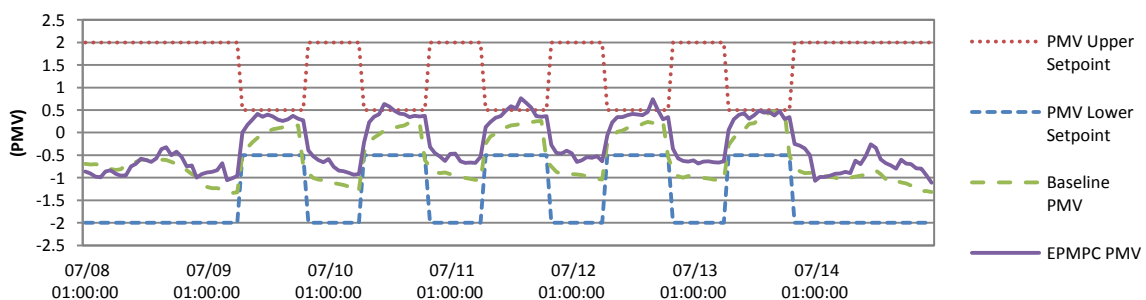

Figure 13 thermal comfort performance of the baseline and EP MPC in summer

## ACKNOWLEDGEMENT

The authors would like to acknowledge National Science Foundation-Emerging Frontiers in Research and Innovation (NSF-EFRI) for funding the study (Award#: 1038139), and the management team of Phipps Conservatory for their continuous support for the research.

## REFERENCES

Bernal, Willy, Madhur Behl, Truong Nghiem, and Rahul Mangharam. "MLE+: A Tool for Integrated Design and Deployment of Energy Efficient Building Controls." *4th ACM Workshop On Embedded Sensing Systems For Energy-Efficiency In Buildings, (BuildSys '12)*. Toronto, 2012.

Castilla, M., J. D. Alvarez, M. Berenguel, F. Rodriguez, J. L. Guzman, and M. Perez. "A comparison of thermal comfort predictive control strategies." *Energy and Buildings* 43 (2011): 2737-2746.

Coffey, Brian, Fariborz Haghighat, Edward Morofsky, and Edward Kutrowski. "A software framework for model predictive control with GenOpt." *Energy and Buildings* 42 (2010): 1084-1092.

Cole, Raymond J., and Paul C. Kernan. "Life-Cycle Energy Use in Office Buildings." *Building and Environment* 31, no. 4 (1996): 307-317.

Daum, David, Frederic Haldi, and Nicolas Morel. "A personalized measure of thermal comfort for building controls." *Building and Environment* 46 (2011): 3-11.

- Dong, Bing. *Integrated Building Heating, Cooling and Ventilation Control (PhD Dissertation)*. Pittsburgh: Carnegie Mellon University, 2010.
- Freire, Roberto Z., Gustavo H.C. Oliveira, and Nathan Mendes. "Predictive controllers for thermal comfort optimization and energy savings." *Energy and Buildings*, 2008: 1353-1365.
- Garcia, Carlos E., David M. Prett, and Manfred Morari. "Model Predictive Control: Theory and Practice - a Survey." *International Federation of Automatic Control* 25, no. 3 (1989): 335-348.
- Gyalistras, Dimitrios. *Use of Weather and Occupancy Forecasts for Optimal Building Climate Control (OptiControl)*. Zurich: swisselectric research, 2010.
- Hazyuk, Ion, Christian Ghiaus, and David Penhouet. "Optimal temperature control of intermittently heated buildings using Model Predictive Control: Part I - Building modeling." *Building and Environment* 51 (2012): 379-387.
- Kolda, Tamara G., Robert Michael Lewis, and Virginia Torczon. "Optimization by direct search: new perspectives on some classical and modern methods." *Society for Industrial and Applied Mathematics* 45, no. 3 (2003): 385-482.
- Kolokotsa, D., A. Pouliezios, G. Stavrakakis, and C. Lazos. "Predictive control techniques for energy and indoor environmental quality management in buildings." *Building and Environment* 44 (2009): 1850-1863.
- Kummert, Michael, Marie-Andree Leduc, and Alain Moreau. "Using MPC to reduce the peak demand associated with electric heating." *Model predictive control in buildings workshop*. Montreal, CA: IBPSA, 2011.
- Lam, Khee Poh, Jie Zhao, and Rongpeng Zhang. "System Integration for Interoperable Data Models of Building Scale Ecosystem." In *Analytics for Building-Scale Ecosystems (BSSE) - U.S. - China Research Perspectives*, 101-110. New York: Begell House, 2013.
- May-Ostendorp, Peter, Gregor P. Henze, Charles D. Corbin, Balaji Rajagopalan, and Clemens Felsmann. "Model-predictive control of mixed-mode buildings with rule extraction." *Building and Environment* 46 (2011): 428-437.
- Moon, Jin Woo, and Jong-Jin Kim. "ANN-based thermal control models for residential buildings." *Building and Environment* 45 (2010): 1612-1625.
- Morosan, Petru-Daniel, Romain Bourdais, Didier Dumur, and Jean Buisson. "Building temperature regulation using a distributed model predictive control." *Energy and Buildings* 42 (2010): 1445-1452.
- Nghiem, Truong X. *MLE+: a Matlab-EnergyPlus Co-simulation Interface*. April 23, 2012. <http://www.seas.upenn.edu/~nghiem/mleplus.html> (accessed February 2, 2013).
- Pang, Xiufeng, Prajesh Bhattacharya, Zheng O'Neill, Philip Haves, Michael Wetter, and Trevor Bailey. "Real-time building energy simulation using EnergyPlus and the Building Controls Virtual Test Bed." *Proceedings of Building Simulation 2011*. Sydney: IBPSA, 2011. 2890-2896.
- Paris, Benjamin, Julien Eynard, Stephane Grieu, Thierry Talbert, and Monique Polit. "Heating control schemes for energy management in buildings." *Energy and Buildings* 42 (2010): 1908-1917.
- Privara, Samuel, Jan Siroky, Lukas Ferkl, and Jiri Cigler. "Model predictive control of a building heating system: the first experience." *Energy and Buildings* 43 (2011): 564-572.
- Sinha, Saurabh. "Exhaustive search." *Introduction to Bioinformatics*. 2008. <http://veda.cs.uiuc.edu/courses/fa08/cs466/schedule.html>.
- Sturzenegger, D., D. Gyalistras, M. Morari, and Roy S. Smith. "Semi-Automated Modular Modeling of Buildings for Model Predictive Control." *BuildSys 2012 - Workshop of ACM SenSys Conference*. New York, 2012. 99-106.
- Wang, Shengwei, and Xinqiao Jin. "Model-based optimal control of VAV air-conditioning system using genetic algorithm." *Building and Environment* 35 (2000): 471-487.
- Yahiaoui, A., J. Hensen, L. Soethout, and A.H.C. Paassen. "Model based optimal control for integrated building systems." *Proceedings of the 6th International Postgraduate Research Conference in the Built and Human Environment*. Delft, Netherlands: University of Salford, 2006. 322-332.
- Yuan, Shui, and Perez Ronald. "Multiple-zone ventilation and temperature control of a single-duct VAV system using model predictive control." *Energy and Buildings* 38 (2006): 1248-1261.
- Zhao, Jie, Khee Poh Lam, Omer T. Karaguzel, and Samira Ahmadi. "Design-Build-Operate Energy Information Modeling (DBO-EIM) for Green Buildings: Case Study of a Net Zero Energy Building." *Proceedings of the 1st IBPSA Asia conference*. Shanghai, 2012.