

DAYLIGHTING AND LIGHTING SAVING ANALYSIS OF OFFICE BUILDINGS IN NORTH CHINA

Hongbing Chen¹, Deying Li¹, Zongyi Shao¹ and K.T. Chan²

¹Key Lab of HVAC, Beijing Institute of Civil Engineering and Architecture,
Beijing 300072, China

²Department of Building Services Engineering, The Hong Kong Polytechnic University,
Hong Kong, China

ABSTRACT

Energy savings by integrating the daylighting availability in the electric lighting management contributes to the realization of 'Green Building'. This paper provides a simulation and calculation of office building in North China with RADIANCE software on the basis of theoretical analysis, which focuses on the influence of Window-to-Wall Ratio (WWR), sill height, glazing transmittance and window shape on Lighting Savings (LS). The study finds out the relationship between those window parameters and LS. The results may be reference for designers as daylighting is involved.

KEYWORDS

Daylighting, Lighting saving, Office building

INTRODUCTION

Daylighting is to bring natural light into buildings, and provide a better indoor light environment than artificial lighting. Daylighting can not only reduce the lighting electricity, but also create a dynamic indoor environment, and a healthy and excited working environment will be produced as follows (Liu and Wang 2000).

Artificial lighting not only consumes a large amount of electricity but also dissipates waste heat into indoor space, which causes the increase of cooling load. However, if effective use of daylight is involved, the decrease of heating, cooling and lighting energy required to condition buildings would come true. Daylighting design (Baker et al. 1993, Hastings 1989) cannot only save energy but also lead to a light, airy architecture of great beauty. In fact, daylighting has become a major topic in energy conscious design, next to passive solar heating and cooling, in recent

years. Studies (Hopkirk 1994, Jiratananon 1987) in the Southeast Asian regions have shown that the use of daylighting can reduce overall energy consumption by 20% and also reduce the sensible heat load on air conditioning.

METHODOLOGY

The simplest example of the radiosity method is that of a spherical enclosure containing a light source. A practical example of such an enclosure would be an integrating sphere used for comparing the light output of light sources.

A single equation (Simons and Bean 2001) can be written representing the energy balance for this situation.

Total incident flux on the sphere interior (F) = The direct flux from the lamp (F_L) + The reflected flux

$$F = F_L + F \times \rho$$

$$F(1 - \rho) = F_L$$

$$F = \frac{F_L}{1 - \rho} \quad (1)$$

The average illuminance on the inside of the sphere,

$$E_{av} = \frac{F_L}{A(1 - \rho)} \quad (2)$$

In the case of a room lit by a window, F_L would be the flux that enters via the window. In a room where the room surfaces had different reflectance, it would be necessary to use the average reflectance of all room surfaces in place of ρ. Let this average reflectance be R then the formula becomes

$$E_{av} = \frac{F_L}{A(1-R)}$$

Where

$$R = \frac{\rho_C A_C + \rho_F A_F + \rho_W A_W}{A_C + A_F + A_W}$$

The term F_L now requires consideration.

If F_L is replaced by TWE_{sky} ($\theta/2$), the formula becomes

$$df = \frac{TW\theta}{2A(1-R)}\% \quad (3)$$

This expression depends upon the fact that the value $\theta/2$ has been found to be a reasonable approximation to the ratio of the illuminance on the vertical face of the window to that on the horizontal from an unobstructed overcast sky (Figure 1), as a percentage.

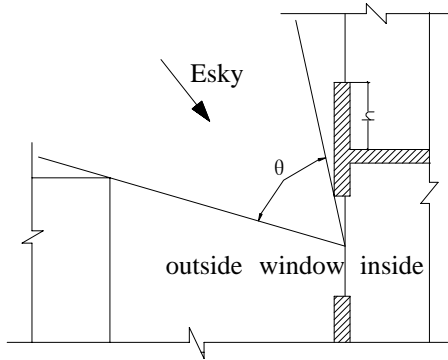

Figure 1 The vertical angle θ of unobstructed sky measured from the middle of the window

Thus,

$$TW \frac{\theta}{2} \times \frac{E_{sky}}{100}$$

is equal to the luminous flux passing through the window into the room.

This gives

$$\frac{E_{av}}{E_{sky}} \times 100\% = \frac{TW \frac{\theta}{2}}{A(1-R)} = \text{average daylight factor within the room} \quad (4)$$

The relationship between the illuminance on the vertical window surface and the angle of unobstructed sky was pointed out by Lynes (Lynes 1979).

However, recommendations for daylight factors are usually given in terms of the average daylight factor required on the working plane; that is at desk or work

bench height above the floor. Crisp and Littlefair (Crisp and Littlefair 1984) have produced a modified version of the Lynes formula as following to give a better estimate of the daylight factor for the working plane.

$$E_{av} = E_{WP} \left(\frac{1+R}{2} \right) \quad (5)$$

where E_{WP} is the average working plane illuminance. Combined For.4 and 5, we can get

$$E_{WP} = \frac{TW\theta E_{sky}}{100A(1-R^2)} \quad (6)$$

SIMULATION AND DISCUSSION

Model description

RADIANCE (Lawrence Berkeley National Laboratory 2001) software is used for the simulation and calculation. Based on the analysis of office layout, a model shown in Figure 2 measuring 6*4*3 m³ is established, with a window on the facade of south and no obstructions. It can be considered as an office room or one part of an open office in North China. Ground reflectance equals to 0.2. The reflectances of floor, ceiling and sidewall are set to be 0.35, 0.75 and 0.75 respectively. The window wall is an external wall and the other three are internal walls. The working plane is 0.8 m above the floor and its required illuminance is 500 Lux. When daylighting is not available, the room should be installed with 24 18-W fluorescent lamps at a height of 2.8 m, 1150 lumens of flux for each one, to meet the demanding illuminance for work. The working plane is divided into 24 zones with 1 m² for each zone. Each lamp is responsible for the lighting of one zone. If the illuminance of a zone is higher than 500 Lux with daylighting available, lighting savings (LS) will be achieved for this zone.

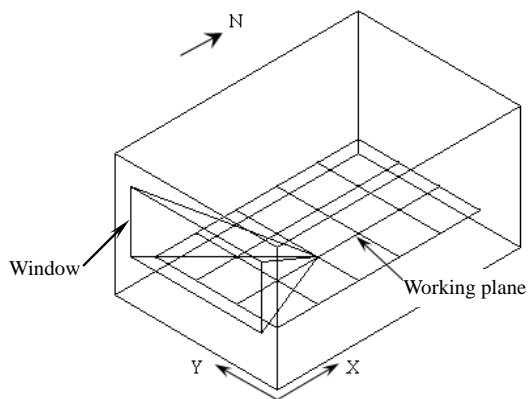

Figure 2 Model for simulation

Influence of glazing transmittance on LS

Window is on the south external wall with a width of 3.2 m and a height of 1.5 m. The height of window sill is 1 m and the Window-to-Wall Ratio (WWR) is 40%. Four glazing transmittances of 0.3, 0.502, 0.617 and 0.81 are involved for the simulation and analysis of the influence of glazing transmittance on Lighting Savings (LS).

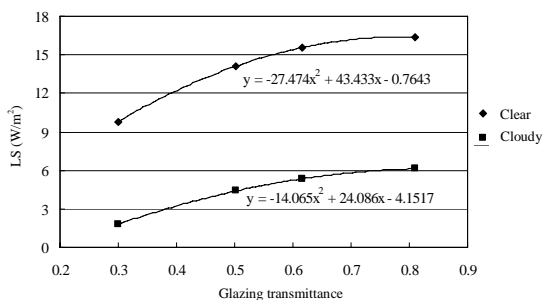

Figure 3 The influence of glazing transmittance on LS

From Figure 3 it can be seen that LS increases with the glazing transmittance going up, and the curves shown in Figure 3 indicate that LS is in quadratic to glazing transmittance. The curves are upwards protruded both in clear and cloudy sky, but it is obvious that the curve of clear sky is steeper than that of cloudy sky, which means the glazing transmittance in clear sky has more influence on LS than that in cloudy sky. With the same glazing transmittance, the LS of clear sky is about 7.5~10 W/m² higher than that of cloudy sky.

Influence of sill height on LS

Window is on the south external wall with a width of 3.2 m and a height of 1.5 m. The glazing

transmittance is 0.502 and the Window-to-Wall Ratio (WWR) is 40%. Four sill heights of 0.9 m, 1.0 m, 1.1 m and 1.2 m are involved for the simulation and analysis of the influence of sill height on LS.

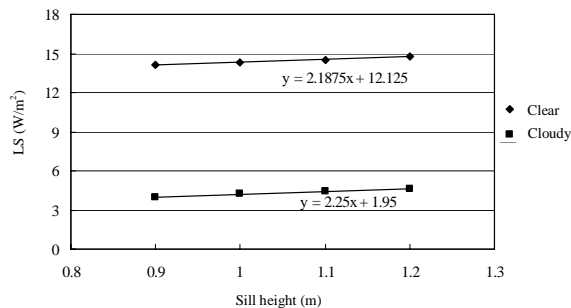

Figure 4 The influence of sill height on LS

From Figure 4 it can be seen that LS is linear to sill height. The higher the sill height is, the more the LS will increase. Furthermore, the two lines of clear and cloudy sky are almost in parallel, which means sill height has the same influence on LS both in clear and cloudy sky. In clear sky, as sill height goes up 0.1 m, LS will increase 0.219 W/m²; in cloudy sky, as sill height goes up 0.1 m, LS will increase 0.225 W/m², 2.7% higher than that of clear sky. LS in clear sky is 10 W/m² higher than that in cloudy sky with the same sill height.

Influence of WWR on LS

Window is on the south external wall. The glazing transmittance is 0.502 and the sill height is 1 m. Four WWRs of 32%, 28%, 24% and 20% are involved for the simulation and analysis of the influence of WWR on LS.

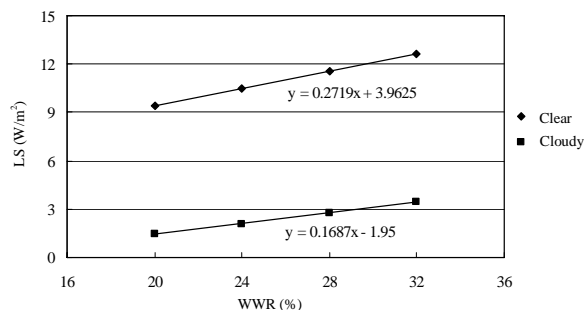

Figure 5 The influence of WWR on LS

From Figure 5 it can be seen that LS is linear to WWR. The line in clear sky is steeper than that in cloudy sky, which means WWR has more influence

on LS in clear sky than that in cloudy sky. In clear sky, as WWR goes up 10%, LS will increase 2.719 W/m²; in cloudy sky, as WWR goes up 10%, LS will increase 1.687 W/m², 40% lower than that in clear sky.

Influence of window shape on LS

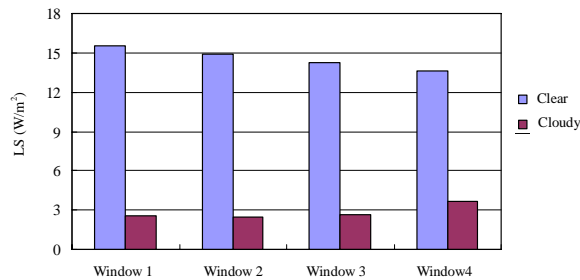

Figure 6 The influence of window shape on LS

Different window shape has different influence on indoor illuminance distribution and LS. The sill height is 1m and the glazing transmittance is 0.502. Four shapes of Window 1 (1.6*1.8 m²), Window 2 (2*1.44 m²), Window 3 (2.4*1.2 m²) and Window 4 (3.2*0.9 m²) with the same WWR of 24% are involved for the simulation and analysis of the influence of window shape on LS.

Those four kinds of windows have the same area of 2.88 m² with a WWR of 24%. But from Figure 6 it can be seen that those four windows have different LS. In clear sky, Window 1 has the most LS of 15.58 W/m², while Window 4 has the least LS of 13.65 W/m², 12.4% lower than that of Window 1. In cloudy sky, Window 4 has the most LS of 3.68 W/m², while Window 2 has the least LS of 2.45 W/m², 33.4% lower than that of Window 4.

CONCLUSIONS

1) LS increases with the glazing transmittance going up, and LS is in quadratic to glazing transmittance. Glazing transmittance has more influence on LS in clear sky than that in cloudy sky. With the same glazing transmittance, the LS of clear sky is about 7.5~10 W/m² higher than that of cloudy sky.

2) LS is linear to sill height. The two lines in clear and cloudy sky are almost in parallel. LS in clear sky is 10 W/m² higher than that in cloudy sky with the

same sill height.

3) LS is linear to WWR. WWR has more influence on LS in clear sky than that in cloudy sky.

4) Different window shape has different influence on LS. In clear sky, Window 1 (narrow and high) has the most LS. While in cloudy sky, Window 4 (wide and short) has the most LS.

ACKNOWLEDGEMENT

The work of this paper is supported by the projects of Beijing Municipal Educational Committee (KM200710016012) and Beijing Municipal Office of Philosophy and Social Science (06BaJG0095).

NOMENCLATURE

- A* Room surface area (m²)
- df* Daylight factor
- E* Illuminance (lux)
- F_L* Input luminous flux (lumens)
- R* Average reflectance of all room surfaces
- T* Glazing transmittance
- W* Glazing area (m²)
- Greek symbols*
- ρ Reflectance
- θ Vertical angle in degrees of unobstructed sky measured from the middle of the window (see Fig.1)
- Subscripts*
- av* Average
- C* Ceiling
- F* Floor
- G* Ground
- W* Wall
- WP* Working plane

REFERENCES

- Liu C., Wang X.. Curtain wall technology of green building [J]. Journal of Chongqi University of Architecture, 2000, 22 (5), pp 27-31.
- Baker N, Fanciotti A, Steemers K, editors. Daylighting in architecture: a European reference book [M]. Comm. of the European Communities, London: James and James (Sc. Publ.), 1993.
- Hastings SR. Computer design tools for climate-responsive architecture. Solar Wind Technol. 1989, 6(4), pp 357-364.

Hopkirk N. Daylighting. In: Hastings R, editor. Passive solar commercial and institutional buildings: a sourcebook of examples and design insights [M]. Int. Energy Agency (IEA), 1994.

Simons R H, Bean A R. Lighting Engineering [M]. Architectural Press. 2001.

Lynes J.A.. A sequence for daylighting design [J]. Lighting Research and Technology, 1979, pp106-114

Crisp V.H.C. and Littlefair P.J.. Average daylight factor prediction. CIBSE National Lighting Conference, 1984, pp

Lawrence Berkeley National Laboratory. Desktop radiance user manual. 2001.