

SIMULATIONS AS THE WAY OF BRIDGING THE GAPS BETWEEN DESIRED AND ACTUAL HYGROTHERMAL PERFORMANCE OF BUILDINGS

Angela Sasic Kalagasidis

Department of Building Technology, Chalmers University of Technology,
Gothenburg 41296, Sweden

ABSTRACT

This paper deals with a common moisture problem in Swedish houses – the occurrence of high moisture levels in attics, and with a remedy proposed by building authorities – the ventilation of attic by outdoor air. The aim of the work is to identify operating scenarios for an attic that lead to a moisture accumulation on internal side of the roof and to investigate whether ventilation (governed by wind) may help in removing the moisture excess. The role of the attic ventilation is analyzed by comparing attics with different air infiltration rates from a dwelling. The investigation aims to exemplify that, by using advanced simulations, a number of sound conclusions can be made by these virtual experiments in a rather easy and inexpensive way.

KEYWORDS

Whole buildings, HAM response, computational analyses, failures in performance, operating scenarios.

INTRODUCTION

Moisture response of a building is a complex and long-lasting physical process – it takes a couple of years before a building is in balance with its surroundings. Consequently, high levels of moisture content in specific building parts, caused by diffusion and convection of water vapor, usually appear after some years of the building usage.

Some of the moisture-related problems in buildings have become widespread in Sweden. About 60 % of damages found in attics are due to the condensation of moisture on internal wooden sides of the roof, whereas minor part, 24 %, can be assigned to direct water leakages through the construction. Spots of mildew on traditional wooden construction elements are usually the first evident signs of high moisture content.

It is perceived that the appearance of higher moisture levels in attics is associated to the increased level of thermal insulation in houses. Today, the average insulation thickness of the attic floor is 380 mm, due to which the climate in the attic gets colder in winter and more susceptible to the transfer of moisture from environment. These attics are then called cold attics.

Building authorities recommend that cold attics should be ventilated by outdoor air and that the attic floor should be constructed airtight. Nevertheless,

problems appear even there where all precautions have been taken.

Experiences from previous investigations

Experiments that treat these problems are time-consuming, expensive and therefore rare. The first and, so far, the only well reported experimental research (Samuelson 1995) revealed that higher moisture levels in attics could be directly correlated to the higher ventilation rates. The results of Samuelson (1995) were used for the validation of a building simulation tool developed by Sasic (2004a and 2004b). The validation tests showed that hygrothermal states in attics could be consistently predicted by numerical simulations if some computational prerequisites were fulfilled:

- Attic should be analyzed as a system composed of construction elements and air zone.
- Attic can be treated as a single air zone and the transport of heat and moisture through construction elements as one-dimensional phenomenon.
- Transport of capillary water in porous building materials is important because the problem involves surface condensation.
- Measured weather data over a longer period of time (a year at least), with naturally correlated weather parameters are essential. Besides outdoor air temperature and relative humidity, the weather data must enclose solar radiation intensity, cloudiness, wind speed and wind direction.

The program, HAM-Tools, was afterwards used in other numerical investigations on hygrothermal conditions in attics (Sasic and Mattsson 2005, Hagentoft 2007), and also for supplementary analyzes to the experimental investigations of Arvidsson and Harderup (2005). The focus of the cited studies was, among other things, on the role of attic ventilation and air infiltration rate from the living space on the hygrothermal situation in the attic.

Simulations also revealed that:

- In the absence of air infiltration from the dwelling, the climate in the attic becomes drier as the ventilation rate decreases.
- If infiltration of air from the dwelling is present, the attic ventilation helps in removing the excessive moisture supply.

- The final outcome of the attic ventilation is, nevertheless, relatively limited, since the ventilation itself brings the moisture to the attic.

The aim of the work presented

When modeling the infiltration of air into buildings, assumptions regarding, for example, wind speed, wind pressure coefficients, positions of leakage paths and ventilation system have to be made. These factors govern the air pressure situation and airflow rates between zones. A lot of uncertainties which are thereby introduced, since true situations are known only after detailed investigations on real houses, suggest that results of air infiltration simulations should be taken with caution. This is usually compensated by detailed parametric and sensitivity analyzes. A set of operating scenarios can be identified by these fast and inexpensive tests, leading to a better understanding of the problem and, at the same time, increasing the confidence in the results.

The work presented here shows some parts of this process - the identification of operating scenarios for a cold attic which may lead to a moisture accumulation on internal side of the roof. The focus is on the airflow rates calculations and the assumptions made on input parameters and boundary conditions. Finally, the resolution in calculated hygrothermal states in the attic is illustrated on selected examples.

About the simulation program

HAM-Tools is a building simulation software. 'HAM' stands for *Heat, Air and Moisture* transport processes in a building and building envelope that can be simulated by this program, and 'Tools' describes its modular structure. The program is designed using the Simulink graphical programming environment (Anon. B) and is composed as a library of block diagrams, where each block represents a certain building part of interest, (Sasic 2004a). As a part of International Building Physics Toolbox (Anon. A), HAM-Tools is an open research tool and publicly available for free downloading.

AIR TRANSPORT THROUGH THE TEST HOUSE

The numerical investigation presented here is performed on a model building whose geometry and construction represent a contemporary single-family house. It is a two-storey building with a timber-framed construction and a cold attic under a 30° pitched roof. The floor area is 6.8 by 11 m and the wall height is 5.3 m. The volume of the attic is 80 m³.

Air tightness of the dwelling

In most cases, the true distribution of air leakages on the building envelope is not known. They are

concentrated around windows, doors and other visible penetrations, but in timber-framed constructions, walls and walls assemblies are also leaky. By taking into account differences in the quality of the workmanship in a building process and cracks that appear during the usage, it is hard to find two houses of a kind. Therefore, a more practical method is used here to decide on the air leakage distribution on the building envelope.

It is convenient to start with the requirements on airtightness; according to the Swedish building code (BBR 2006), the air tightness of a residential house should be less than 0.8 l/m²s of the surface area that separates the indoor climate from the outdoor one, or from any unheated space, at 50 Pa pressure difference across the building envelope. This gives the air change rate of the test house $n_{50} = 2.45$ 1/h.

The mean leakage factor \bar{k} (m³/m²/s/Pa^β) of the building envelope is introduced as:

$$\bar{k} = \frac{n_{50} \cdot V}{50^{\beta} \cdot A} \quad (1)$$

where V is the volume of the house, A is the area that separates the indoor climate from the outdoor one and $\beta = 0.65$ is the exponent in the equation.

The mean leakage coefficient of the ceiling, $k_{ceiling}$ (m³/m²/s/Pa^β), is related to the mean leakage coefficient of the walls, k_{walls} , in the following way:

$$k_{ceiling} = b \cdot k_{walls} \quad (2)$$

It is normally to expect that there are fewer penetrations in the ceiling than in the walls, so that the parameter b takes values which are less than 1. The following equation is also fulfilled:

$$\bar{k} = \frac{A_{walls} \cdot k_{walls} + A_{ceiling} \cdot k_{ceiling}}{A_{walls} + A_{ceiling}} \quad (3)$$

where A_{walls} and $A_{ceiling}$ are areas of the walls and the ceiling. Note that the walls are assumed equally leaky, but it is possible to distinguish them in a similar way, and that the floor in the house is airtight.

Air tightness of the attic floor

The parameter b in equation 2 is, together with n_{50} , the type of the ventilation system and the house exposure to the wind, the decisive parameter for the assessment of the airflow rate through the attic floor. The "best case" value is $b=0.25$, which gives 0.22 1/h through the ceiling at 50 Pa pressurization test. It represents the least air permeability of the attic floor that should be accounted for. This value is determined by measurements, as it is explained hereafter.

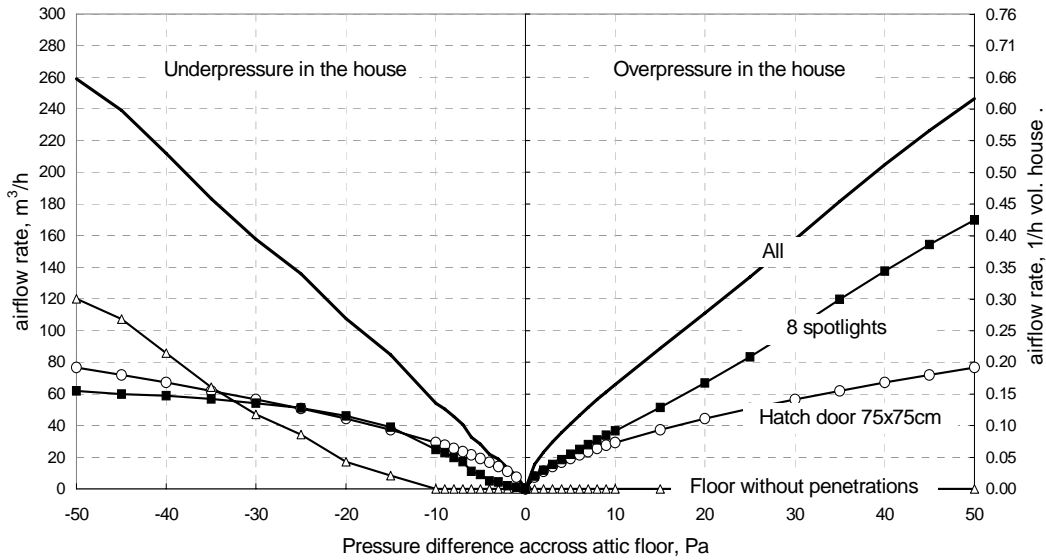

Figure 1 Measured flow characteristics for a typical ceiling in a timber-framed construction, with and without penetrations (spot lights), from Mattsson (2007). Data for the hatch door from AIVC (2002).

Measured data on the airflow rate through some typical assemblies, cracks and penetrations in the attic floor of a timber-framed construction can be found in Mattsson (2007). By combining the data for a ceiling without penetrations (Mattsson 2007) with the data for a common hatch door (AIVC 2002), it can be found that about 200 m³/h passes the attic floor at 50 Pa underpressure in the house, and 80 m³/h at 50 Pa overpressure. This corresponds to 0.5 to 0.2 1/h through the ceiling of the house treated, see Figure 1. Situations with the overpressure in the house are of more interest here, so the second value is used. It could be expected that there are differences in the air permeability of the hatch door at overpressure and underpressure in the house, but these cases are not distinguished in the reference (AIVC 2002). Note that *b* is highly correlated to the selected volume and area of the house.

Ventilation system of the house

Majority of houses which are built after 1980's are mechanically ventilated and the exhaust only ventilation system prevails. The exhaust fan provides an underpressure in the house, whose designed value is around 5 Pa. This value should secure the stable functioning of the fan, not affected by, for example, wind induced pressure disturbances. The underpressure in the living space is a positive feature for it protects the warm humid air from inside the house to flow upward to the attic. There are circumstances, as it is shown in the text that follows, when the pressure situation around the house counteracts the effect of the exhaust fan and the indoor air flows into the attic.

Similar analysis is given for the exhaust-supply ventilation system. The air flow through the supply fan is about 85 % of the flow through the exhaust fan and the resulting underpressure in the house is

around 1-2 Pa. The exhaust-supply system is far more affected by pressure fluctuations around the house and, consequently, there are a number of occasions when the air flows upwards to the attic. This is why it is taken here into the consideration.

The flow characteristics of the exhaust and supply fans and of the leakages in the building envelope of the test house are shown in Figure 2. The designed underpressure in the house with the exhaust only ventilation system is between 4 and 5 Pa at 0.5 1/h air change rate. Note that vents for the air intake are not included – the leakages seem to be sufficient for the air supply. In case of the exhaust-supply ventilation system, the underpressure in the house is less than 1 Pa.

Ventilation of the attic

Attics are ventilated through openings (app. 20 mm wide) which are placed along roof eaves. The airflow rate through the opening was measured by Mattsson

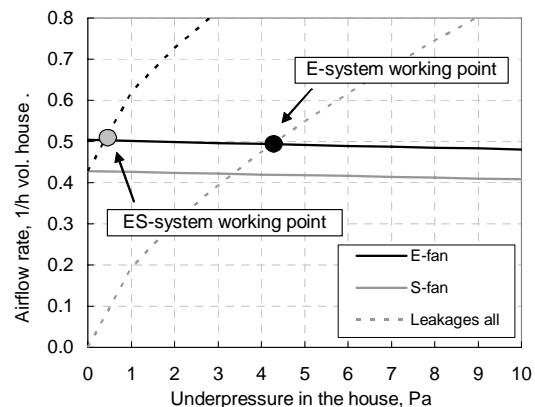

Figure 2 Flow characteristics of the exhaust (E) and the supply (S) fan and of the leakages (Eq. 1) in the building envelope of the test house.

(2007); it can be approximated by a power-law equation with the flow coefficient that equals to 78 m³/h/m and with the exponent of 0.5, giving 28 1/h (of the attic volume) at 50 Pa pressure difference. Air infiltration through leakages in gable sides is also taken into consideration, even though it is several orders of magnitudes less than the flow through the ventilation openings. (~ 0.1 1/h vol. attic).

Network components in the airflow model

Air flow through all building components of interest is illustrated by the network in Figure 3. The pressure states on the outer sides of walls, roofs and gables are governed by the wind. The pressure inside the house is influenced by the wind, the pressure in the attic and by the temperature difference between the outdoor and indoor air – the stack effect.

The model distinguishes the windward and the leeward side of the building. Overpressure caused by the wind at the windward side will contribute to the greater air inflow in the lower part of the subjected surface, e.g. below the neutral pressure plane. Consequently, due to the underpressure, the air outflow at the leeward side will increase in the upper part of the surface. These effects are indicated by placing the neutral pressure plane at the windward side above the neutral pressure plane on the leeward side, as it is depicted in Figure 3.

Pressure in the house is found iteratively from the mass balance equation:

$$\sum_i \sum_j m_{ij} = 0 \tag{4}$$

where m_{ij} is the mass air flow rates through a leakage area which is placed on the façade number i :

$$m_{ij} = \rho_j A_{ij} k_i (\Delta P_{stack,i,j} + \Delta P_{wind,i})^{n_i} \tag{5}$$

The index j denotes the position on the facade in respect to the neutral pressure plane (NPP), telling about the airflow direction, see Figure 3. The airflow area (above or below NPP), A_{ij} , changes as the neutral pressure plane moves. ρ is the density of air (kg/m³), k is the mean flow coefficient of the surface, ΔP_{stack} (Pa) and ΔP_{wind} are pressure differences across the surface caused by stack and wind effects. n is the flow exponent.

Pressure in the attic is found in a similar way, i.e. by finding the mass balance of all flows through the attic. The stack effect is neglected here.

THE NUMERICAL MODEL OF THE HOUSE

The airflow calculations are performed by the A-Tools, which is a sub-library of models in the HAM-Tools. There are two A-blocks in question: the one calculates the air pressure in the dwelling, assuring the mass balance of all incoming and outgoing flows, and the other does the same calculations for the attic. These blocks can be run together with the whole hygrothermal model of the attic, as it is shown in Figure 4, or as stand-alone applications, decoupled from the hygrothermal model. The first alternative will give the mass airflow rates which are based on the actual thermal and moisture states in the attics. The climate attic in the may differ a lot from the outdoor one due to, for example, the influence of solar radiation. The second alternative is convenient in the design phase, when some decisions on air leakage distributions or fan flow characteristics are to be made; the mass flow rates are then based on the

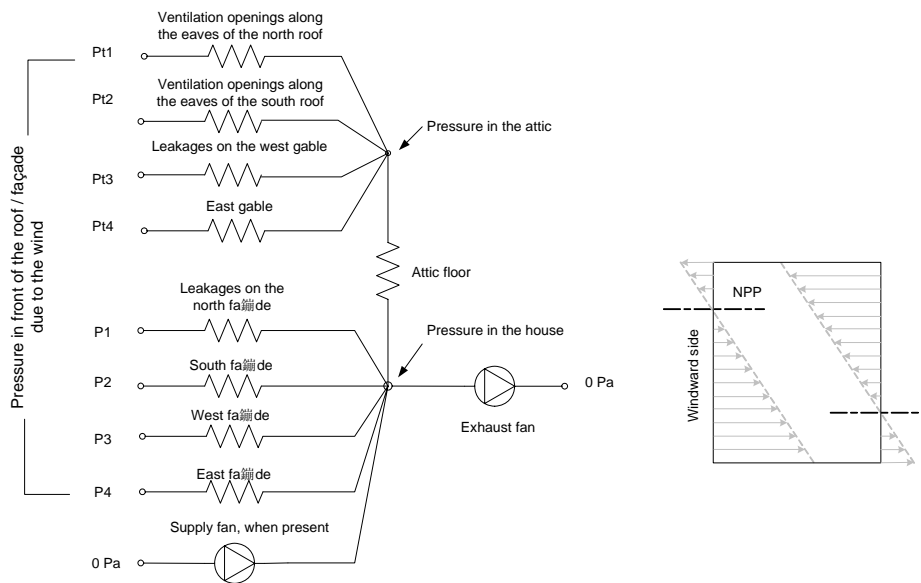

Figure 3 Airflow network composed of all components involved in the analyzes (to the left). Position of the neutral pressure planes (NPP) at the windward and the leeward side of the house (to the right). Air inflow (outflow) above and below the NPPs are indicated by arrows.

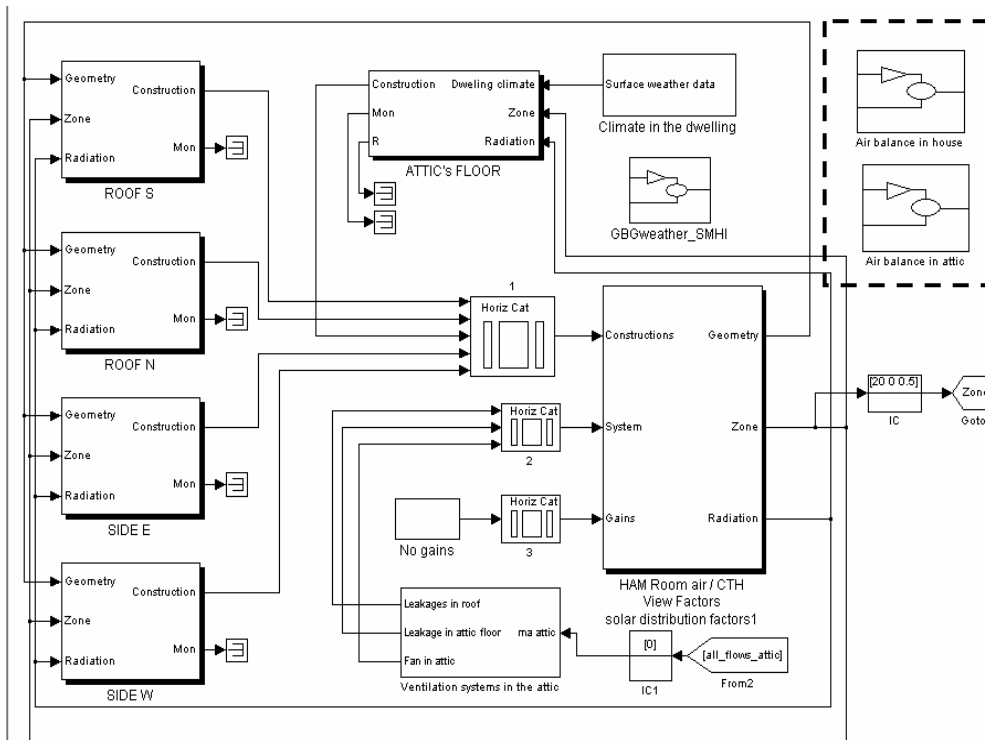

Figure 4 Numerical model of the attic in HAM-Tools. Modules that support airflow calculations (A-Tools) are squared by the dashed line, in the upper right corner.

outdoor or any other known climate.

Coupling of the A-Tools with the HAM-Tools is not an easy numerical task. The hygrothermal model of the attic includes continuous states due to the heat and moisture capacity of building components and the air, while the attic airflow model has the non-continuous states. When the A-blocks are used as the stand-alone applications, a discrete numerical solver is used. When they are used together with the HAM-model of the attic, a continuous numerical solver is used both for the continuous and for the discrete problem. Unlike from before, it seems not be a problem any more to run the both type of simulations using the standard numerical solvers in Simulink. Simulations are slower, since the A-models do a number of iterations within each time step; hence, they are smoothly performed, without any numerical problems.

OPERATING SCENARIOS BASED ON THE AIRFLOW RATE THROUGH THE ATTIC FLOOR

As it is discussed before, the warm humid air that comes from the dwelling to the attic is considered as a moisture source, because the water vapor it brings with condensates on considerably colder surfaces in the attic. Due to the long-wave radiation exchange with the sky, the roof sides are the coldest parts of the attic during the night, and their under sides the most vulnerable ones. The amount of moisture that comes from the dwelling is higher if the infiltrating air is warmer and more humid, but it is also directly

proportional to the infiltration rate. Having the same climate in the dwelling, the four cases about different infiltration rates are selected for the analysis:

- Case “a”, representing the house designed according to the Swedish requirements for airtightness and with exhaust only ventilation system (parameter $b=0.25$).
- Case “b”, representing the house whose airtightness is slightly decreased in comparison to the one from the case a. This can easily happen in reality when some new penetrations are made in the ceiling, as by installing the spotlights (see Figure 1). The house has the exhaust ventilation system (parameter $b=0.7$).
- Case “c” is the house with the same airtightness as in the case b, but with the exhaust-supply ventilation system (parameter $b=0.7$).
- Case “d” is the carelessly built house whose air tightness is much higher then what is required by building regulations, and which has the exhaust-supply ventilation system ((parameter $b=1$).

The airflow parameters for all four cases are summarized in Table 1. Note that these cases are constructed in such a way to be clearly different from each other when assessing the airflow rate through the attic floor, but also to represent realistic situations. Table 2 shows the infiltration airflow rates from the dwelling and through the ventilation openings in the attic. Note that the first are at least one order of magnitude less then the latter.

Table 1 Parameters describing the airtightness of the dwelling and the ceiling for the cases analyzed

b	CASES ANALYZED	n_{50}	$n_{50,ceiling}$
		1/h vol. house	1/h vol. house
0.25	a	2.45	0.22
0.70	b, c	3.00	0.65
1.00	d	5.00	1.42

Differences caused by the ventilation system are illustrated in Figures 5. The underpressure caused by the exhaust-supply ventilation system is not enough to counteract the pressure difference caused by stack and wind effect. The exhaust only ventilations system works better but has the difficulties during the windy periods.

Results from Figure 5 are obtained by A-Tools. The wind velocity at the site is estimated by the power law profile, assuming urban surrounding from the British Standard terrain classification (corresponds well to the “suburban” classification in the ASHRAE standard), (Sanders, 1996).

Table 2 Airflow rates through the attic floor (from inside the dwelling) and through the attic ventilation system (from outdoors). Yearly averages.

b	INFILTRATION FROM THE DWELLING		VENTILATION THROUGH THE OPENINGS	
	1/h vol. attic		1/h vol. attic	
	Exhaust	Exhaust-supply	Exhaust	Exhaust-supply
0.25	0.03 a	0.15	6.38 a	6.41
0.70	0.08 b	0.38 c	6.52 b	6.59 c
1.00	0.31	0.80 d	6.68	6.92 d

THE HYGTROHERMAL RESPONSE OF THE ATTIC

Due to the solar radiation and long-wave radiation heat exchange with the sky, the climate in the attic significantly differs from the outdoors one. During the night, the attic gets colder than the outdoor air. Not only the water vapor from the air that infiltrates from the dwelling, but also the vapor from the outdoor air coming through the ventilation openings, condensates on the roof sides. During the sunny days, the roof gets warmer and dryer. The rate of drying or wetting depends on the climate and on the moisture loads. The climate which is used here is favorable for the wetting process; it represents the southwest coastal area of Sweden, characterized by mild and humid winters and summers.

The following details are important for the hygrothermal calculations: the roof is covered with concrete tiles on the outer side, followed by an airtight and vapor tight underlay and lined with 19 mm thick wooden spruce boards on the internal side. Gable sides are constructed of wooden boards and painted on the outer side. The attic floor is insulated

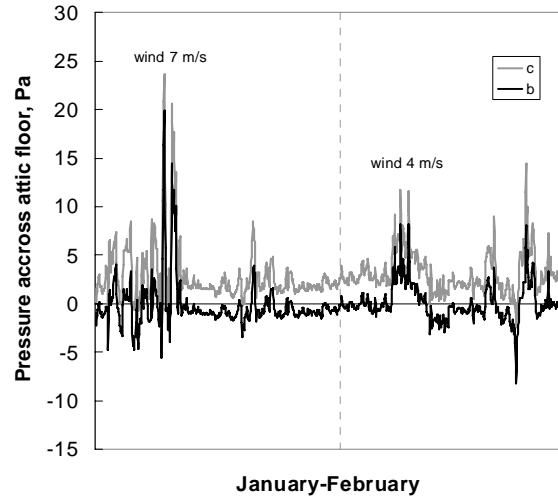

Figure 5 Pressure difference across the attic floor (inflow when positive) due to the stack and wind effect, and the ventilation system (cases c and d).

with a 400 mm thick loose-fill insulation with an air barrier below and gypsum board as internal lining. Thermal and moisture transport properties for the materials involved may be found in Kumaran (1996).

The hygrothermal response of the attic is summarized in Figures 6 and 7. Each figure shows weekly averaged relative humidity on internal side of the roof (the north roof is in Figure 6, the south in Figure 7) during a year, for cases a-d. Temperature of the internal side of the roof is given in the bottom part of each figure, also as the weekly averaged value.

Since there is negligible difference in the roof temperature between the cases, only one result is presented (in each figure). However, there is a clear difference in the moisture content, starting from the lowest one for case a, and ending with the highest one for case d. For the north roof the difference is largest in spring (weeks 12-20, April-May), negligible in summer, and then again visible in autumn (from week 38, October). A similar behavior is read for the south roof, in Figure 7, with somewhat more pronounced differences. Finally, there is a clear difference between the roof sides – the south roof is much dryer than the north one.

The assessment based on the criterion for the mould growth

The hygrothermal states on the roof sides can be evaluated by using a criterion for the mould growth. Lines denoted as 4 weeks, 12 and 24 show the minimum time and the minimum relative humidity during that time which is required for the onset of mould growth on spruce and pine, (Lehtinen and Harderup, 1997). Each marker on the line showing the relative humidity represents one week. Thus, by counting the markers over a certain criterion, the risk for the mould growth can be easily assessed.

Microbiological growth does not necessarily deteriorate the construction, but the spores of fungi,

which are easily spread through the house by air movement, may cause discomfort in the form of a musty smell or allergic irritation.

The results clearly show that:

- Water vapor transported by air infiltration from the dwelling represents a significant moisture load in the attic. The higher the infiltration rate is, the higher the moisture content in the roof side is.
- Exhaust only ventilation system is better for limiting the air infiltration to the attic, in comparison to the exhaust-supply system.
- Air infiltration rate is lower if the air tightness of the dwelling is better.
- The north roof side is more vulnerable than the south sunny side.
- It is also apparent that attic ventilation has a limited effect in removing the moisture coming from inside the dwelling.
- In all cases, the hygrothermal states on the north side of the roof fulfill criteria for the mould growth, particularly in autumn, even there where the moisture load from the dwelling is negligible (case a). This is because the ventilation itself brings the moisture to the attic.

Some of these conclusions are known from the experimental studies, but the once refereeing to, for example, the role of the house ventilation system and the airtightness of the house can not be easily revealed without simulations. This is because such details introduce many unknown parameters in field studies, not only by their number, but mostly because of their high correlation.

THE OUTLOOK

The problem presented shows that it is of a high practical interest to support the development of calculation tools which can treat the hygrothermal response of buildings to the sufficient detail. The possibility for parametric studies and systematization of results are proven to be important advantages of numerical investigations in comparison to field studies.

Results presented here are obtained by HAM-Tools, which is a simulation program for hygrothermal analyzes in whole buildings. The tool is currently used in a research program about the controlled ventilation of attics (Hagentoft, 2007). The controlled ventilation is an innovative method and protected by the patent (Anon. C).

As a part of International Building Physics Toolbox (IBPT, 2002), HAM-Tools is an open research tool and publicly available for free downloading.

REFERENCES

Anonymity A www.ibpt.org

Anonymity B www.matlab.com

Anonymity C www.ventotech.com

AIVC Air infiltration and ventilation centre. 2002. Ventilation modelling data guide. Available from www.aivc.org.

Arfvidsson J., Harderup L-E. 2005. Moisture Safety in Attics Ventilated by Outdoor Air. The 9th Symposium in Building Physics, Reykjavik, Island.

BBR. 2006. Swedish building regulations. BFS 1993:57 with changes up to 2006:22. (In Swedish)

Hagentoft, C.-E., 2007. Effects and the cost of controlled ventilation of cold attics. Report from the SBUF project 11871, financed by the Swedish construction industry's organization for research and development.

Kumaran, K. 1996. IAE Annex 24, Final Report, Volume 3, Material properties. KU Leuven, Belgium, Laboratorium Bouwfysica.

Lehtinen, T., Harderup, L-E. 1997. Safety factor based physical design procedures-framework and case examples of wooden wall structures. IUFRO 5.02 conference Copenhagen, Denmark, June18-20, 1997.

Mattsson, B. 2007. Measurements of air leakage through building envelope parts and idealized leakage paths using transient method. To appear in J. Build. Physics.

Samuelson, I. 1995 Moisture balance in the cold attics. The importance of Ventilation and Choice of Insulation Materials. In Swedish. SP rapport 1995:68. Borås, Swedish National Testing and Research Institute.

Sanders, C. 1996. IAE Annex 24, Final Report, Volume 2, Environmental conditions. KU Leuven. Belgium, Laboratorium Bouwfysica.

Sasic Kalagasidis A. 2004a. HAM-Tools. An Integrated Simulation Tool for Heat, Air and Moisture Transfer Analyses in Building Physics. Doctoral thesis. Chalmers University of Technology, Sweden.

Sasic Kalagasidis A. 2004b. "The whole model validation for HAM-Tools. 2004. Case study: hygro-thermal conditions in the cold attic under different ventilation regimes." 9th International Conference on Performance of the Exterior Envelopes of Whole Buildings. Clearwater Beach, Florida

Sasic Kalagasidis A., and B. Mattsson. 2005. Modelling of moisture conditions in a cold attic space. 26th AIVC conference, Brussels, Belgium.

Weitzmann, P., Sasic Kalagasidis, A., Nielsen, T.R., Peuhkuri, R., Hagentoft, C-E. 2003. Presentation of the International Building Physics Toolbox for Simulink. 8th International Building

Performance Simulation (IBPSA) Conference,
Eindhoven, the Netherlands.

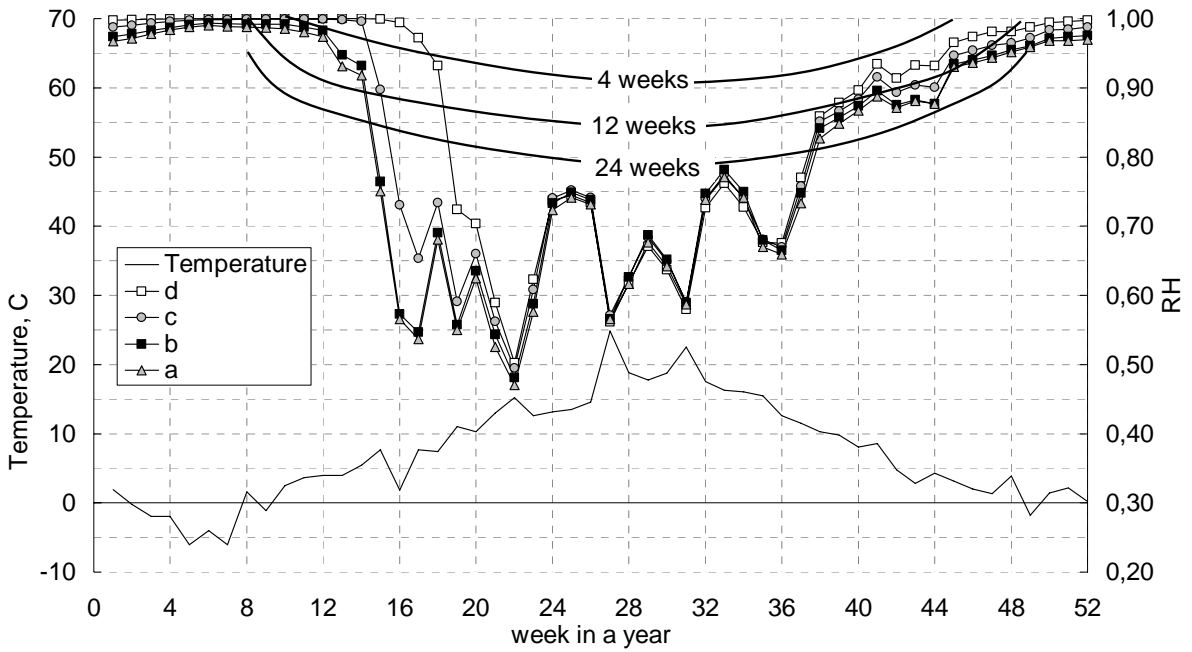

Figure 6 Weekly mean relative humidity and temperature on internal side of the north roof. Ranges critical for the mould growth are indicated in the middle upper part, according Lehtinen and Harderup (1997).

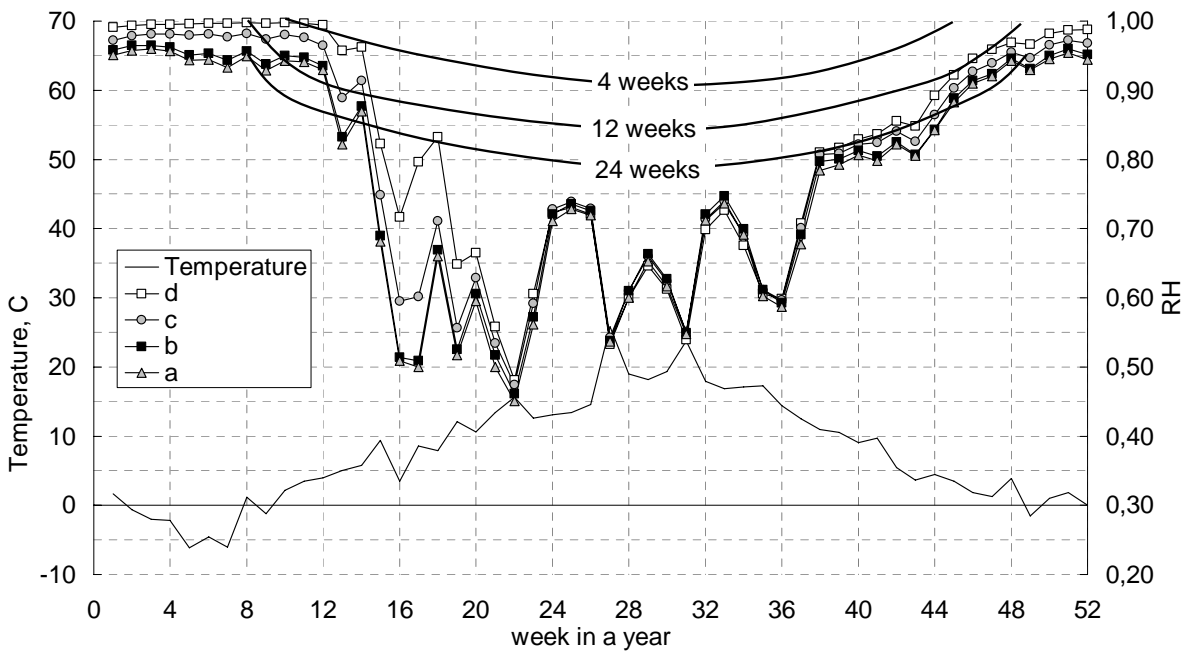

Figure 7 Weekly mean relative humidity and temperature on internal side of the south roof. Ranges critical for the mould growth are indicated in the middle upper part, according Lehtinen and Harderup (1997).