

© INIVE EEIG  
Operating Agent  
and Management  
Boulevard Poincaré 79  
B-1060 Brussels – Belgium  
inive@bbri.be - www.inive.org

International Energy Agency  
Energy Conservation in Buildings  
and Community Systems Programme



Air Infiltration and Ventilation Centre

## Air quality in passenger aircraft

James P. Rydock  
SINTEF Building & Infrastructure, Norway

### 1 Introduction

This VIP focuses on best practice, as well as challenges, for the conditioning of the indoor environment in passenger aircraft cabins, and their implications from a ventilation standpoint. This article is based largely on findings from EU's FP5 project 'CabinAir' (see on last page).

### 2 Aircraft cabin ventilation

In early commercial jet aircraft, passenger cabins were ventilated with 100% outside air. In more recent jet aircraft, approximately 50% of the ventilation air is outside air and the remaining 50% is filtered recirculated cabinair. This development has allowed for fuel savings as well as a supposed improvement in the relative humidity of cabin air.

With typical passenger densities in modern airline cabins employing partial recirculation of cabin air, however, carbon dioxide concentrations have been shown to exceed 1000 ppmv (parts-per-million by volume) in some sections of the cabin on some flights. This has raised the question of whether air quality and ventilation are acceptable in modern jet airliner cabins.

In order to provide insight into the nature of the challenge of ventilating airliner cabins, a brief overview is given here of how outside air is transported into the cabin and conditioned to the point where it can serve as ventilation air to keep passengers and crew safe, healthy and comfortable. The in-flight supply of outside air is almost without exception bled from the engine compressors.

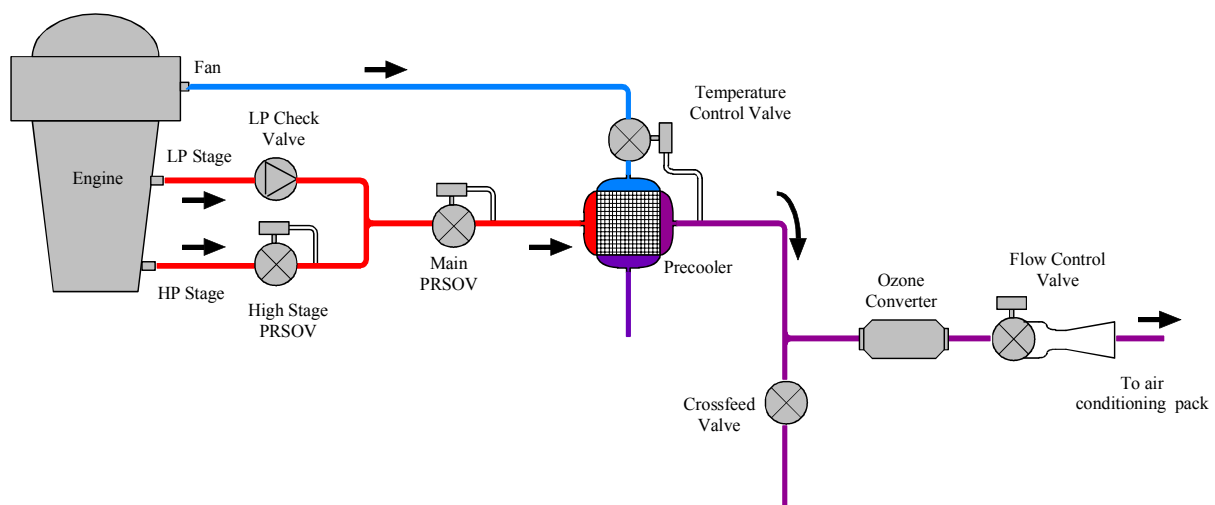

Figure 1 : Typical bleed system for a modern commercial aircraft

The hot compressed air from the engines is then conditioned by the environmental control system (ECS) and distributed throughout the cabin. Bleeding air from the compressors for pneumatic services has a detrimental effect on engine performance and consequently attempts are made to minimise it.

As engine operating characteristics tend to vary quite substantially over a flight (taxiing, climb, cruise and descent), the temperature and pressure of the bleed air also vary over a wide range. Temperatures can vary from 65 °C to 650 °C and pressures can range from 10 to 600 psig [70~4136 kPa (guage)]. A complex conditioning system is therefore required to provide a constant flow of ventilation air to the cabin throughout a flight.

Most modern commercial aircraft employ bleed switching such as the system shown in Figure 1. During the higher engine power settings that are experienced during aircraft climb and many cruise conditions, the bleed air is taken from the low pressure (LP) stage bleed port. In these cases where the LP stage is sufficient, the high stage pressure regulating and shut-off valve (PRSOV) will be commanded closed. This is achieved either pneumatically or from an electronic controller that receives signals from the engine FADEC (Full Authority Digital Engine Control). When the aircraft is in certain mission phases such as ground taxi, flight idle and some low speed cruise conditions, the LP stage output will be insufficient to meet the pneumatic system demands. Under these conditions, the high stage valve will be commanded open and high-pressure air will mix with the LP air. When the manifold pressure exceeds that being supplied by the LP stage port, the LP stage check valve will close, preventing backflow into the engine, and the HP bleed will become the sole supply. As soon as the engine power rises to a sufficient level, the high stage PRSOV will be commanded shut and the LP bleed port will again supply the pneumatic system.

While the engines are not running but the aircraft is occupied, for example during boarding and deplaning while stopped at a gate, the ECS requires an alternative source of compressed air in order to function. This can be provided by the aircraft auxiliary power unit (APU), a small on-board engine designed to be

a backup in case the engine bleed system fails, from a ground cart or from a central ground air supply [ref.5].

Because of the acoustical and air quality impacts associated with APU and ground carts at airports, there is evidence that a centralized, subterranean air supply may be preferable [ref.4].

Compressed air delivered to the ECS must be cooled. A typical means of doing this is through a precooler heat exchanger shown in Figure 2. The precooler will reduce the bleed air temperature to a more manageable level rather than that actually required at the ECS inlet. A design aim is usually for the temperature of the air at the precooler outlet to be below the flashpoint temperature of the fuel that is stored in the wings.

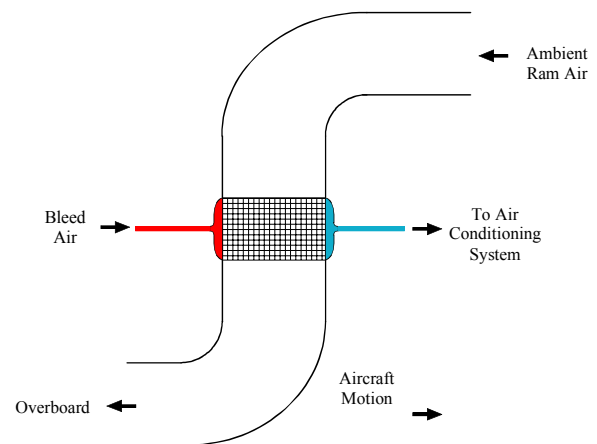

Figure 2 : Ram air cooling of precooler

Almost all aircraft air conditioning systems utilise the air cycle to provide cooling. Unlike vapour compression systems that utilise latent heat transfer, the air cycle operates around the principle that when a perfect gas is compressed or expanded its temperature will rise or fall respectively. The theoretical cycle that corresponds most closely with the air cycle is the reversed Joule or Brayton cycle shown in Figure 3. It consists of isentropic<sup>1</sup> compression and expansion processes and isobaric heat transfer processes.

<sup>1</sup> Isentropic means constant entropy, i.e. an ideal lossless process where the system neither absorbs nor gives off heat. Isobaric means constant pressure.

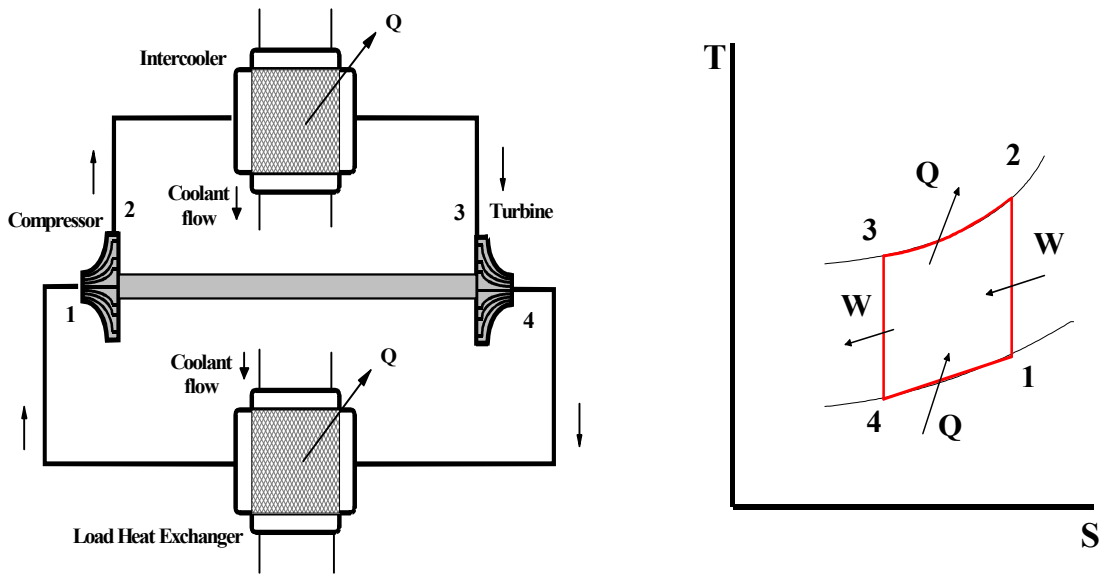

Figure 3 : Reversed Joule or Brayton cycle. Air is drawn into the compressor at point 1, where both its pressure and temperature are elevated. The high temperature is undesirable and consequently the air is passed through an intercooling heat exchanger (points 2 to 3) before it is delivered to the expansion device, which is normally a turbine. Through the process of expansion (points 3 to 4); the air temperature is reduced further, until it reaches the required level. Finally, the cold stream of air flows through the load heat exchanger (points 4 to 1), thus removing heat from the cooled space before the cycle re-commences.

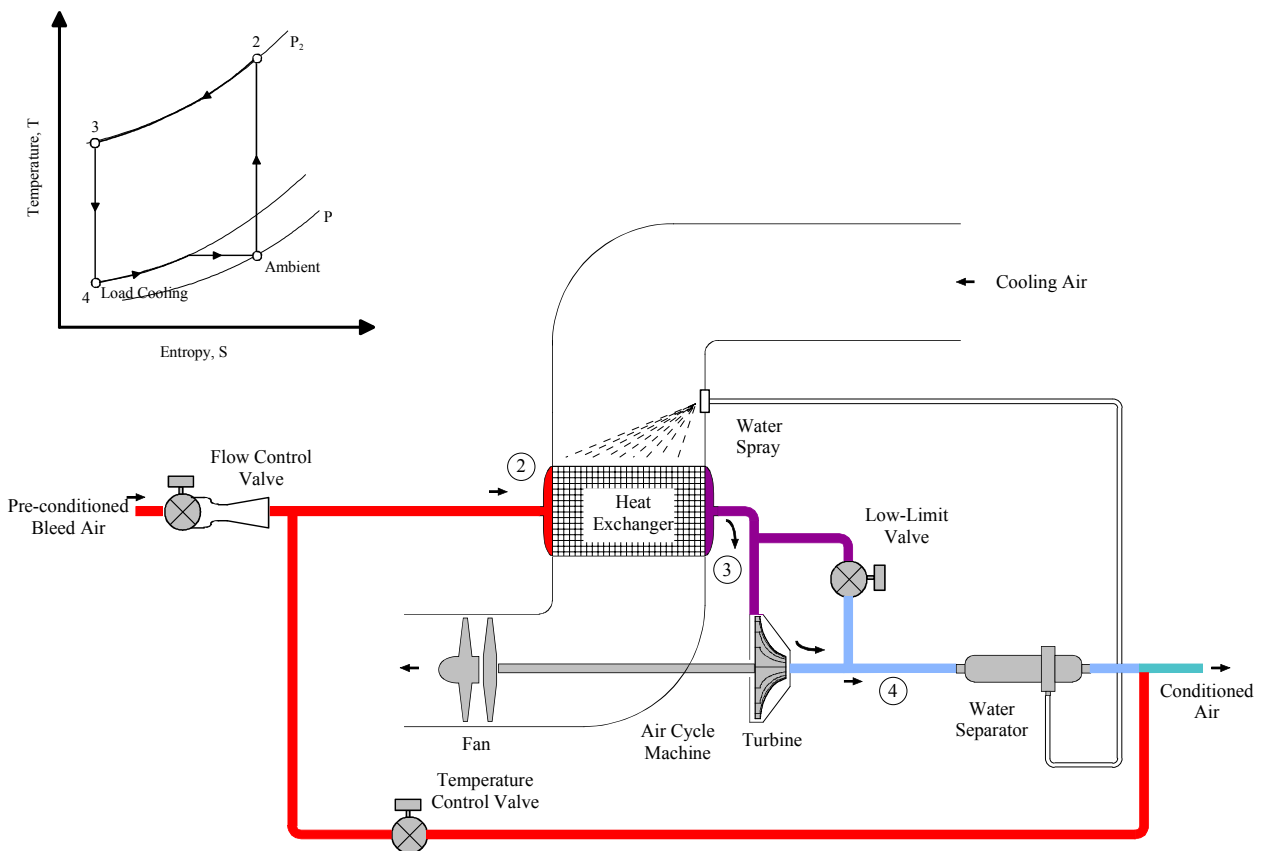

Figure 4 : Simple turbofan system for aircraft air conditioning system

The simplest air cycle system is the turbofan, shown in Figure 4. In this system, high-pressure air is first cooled in a ram air-cooled heat exchanger. It is then expanded through a turbine to gain further cooling. The expansion energy is used to drive a fan that induces cooling air through the ram-cooled heat exchanger. On leaving the turbine, the air is passed through a low-pressure water extractor where any free water, which has condensed from the air, is removed. This water is sprayed back into the ram air circuit to take advantage of the evaporative spray cooling effect.

Turbofan systems have found use in aircraft with high-pressure ratio engines, subsonic military aircraft, helicopters and small commercial, regional and business aircraft.

Larger commercial jets employ more complex systems.

For distribution of the conditioned air, the main practice is to let the air enter the cabin at the centre of the ceiling and close to the side wall panels and then leave the cabin through the grills at the lower part of the side walls panels (see Figure 5). The objective of the air distribution system is to give equal ventilation in the longitudinal cabin direction. That means that every meter of cabin gets the same amount of ventilation air, independent of whether it is in the front, the middle or the aft of the cabin. This principle, together with an equal suction from the cabin to the under floor area minimises longitudinal flows within the cabin.

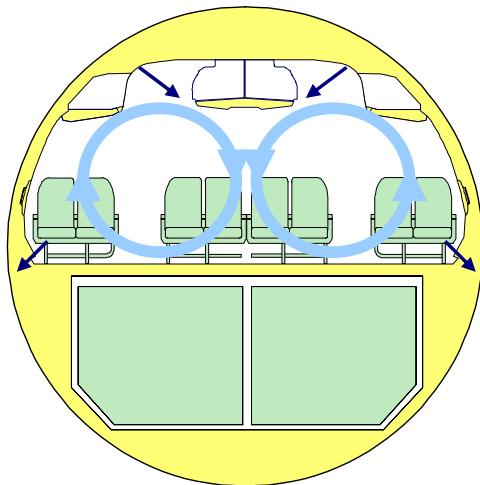

- Flow from upper part of the cabin downwards
- One air outlet per cabin side
- Outlet position ensures good ventilation to aisles and passenger areas

Figure 5 : Example of airflow patterns in twin-aisle cabin

### 3 Aircraft cabin air quality and thermal comfort

All commercial aircraft must be certified according to the Federal Aviation Administration (FAA) Regulations and/or the European Aviation Safety Agency (EASA) Certification Specifications. These documents regulate all aspects of aircraft performance, including the amount of compressed air that is required for ventilation. The EASA specifications stipulate only that ‘Each passenger and crew compartment must be ventilated and each crew compartment must have enough fresh air (but not less than 0.28 m<sup>3</sup>/min ... [4.7 litres/second] per crew member) to enable crew members to perform their duties without undue discomfort or fatigue’ [ref.1]. The FAA, on the other hand,

requires that ‘For normal operating conditions, the ventilation system must be designed to provide each occupant with an airflow containing at least 0.55 lb of fresh (outside) air per minute’ [ref.2]. This is functionally equivalent to the EASA specifications, as 4.7 litres weigh approximately 0.55 lbs at a typical cruising cabin pressure and temperature. Furthermore, as amended in 1996 to allow for the use of recirculation: ‘Section 25.831 (a) as amended permits a ventilation system that uses a mixture of the minimum amount of fresh air and any desired quantity of recirculated air that is shown to be uncontaminated by odours, particulates, or gases’ [FAR Amdt. 25-87, 1996]. EASA’s harmonized state ‘where the air supply is supplemented by a recirculating system, it should be possible to stop the recirculating

system and ... Still maintain the fresh air supply prescribed' [AMC 25.831(c), 2003]. Other amendments by FAA (1997) and EASA require a maximum of 5000 ppmv (sea-level equivalent) of CO<sub>2</sub> [ref.1,2].

Aircraft cabin ventilation systems have been designed and implemented in accordance with these requirements, and with the addition of recirculation flow, usually significantly exceed them. However, there has been some discussion as to whether these required ventilations rates are appropriate, so bodies such as ASHRAE have been trying to come to a consensus about new guideline values.

#### 4 Measurement results from CabinAir

The monitoring program was carried out by NBI (now SINTEF), BRE and TNO working in cooperation with British Airways, KLM, and Scandinavian Airlines and both Airbus and Boeing. The 50 flights were undertaken on eight aircraft types (Airbus A319, A321, A340, Boeing B737, B747, B757, B767, and MD11) representing the current modern fleet. Figure 6 gives an example of measurements taken at a seat on a monitored flight. The head-ankle temperature gradient was generally low, but was in excess of 5 °C at around 04:46 GMT. The CO<sub>2</sub> concentration was above 1000 ppmv for much of this particular flight. For all flights taken together, the CO<sub>2</sub> concentration exceeded 1000 ppmv in business class for 40% of the time and in economy class for about 65% of the time. Though the carbon dioxide concentration in the cabin was very often over 1000 ppmv in both business and economy classes for all flights taken together, concentrations over 1500 ppmv were relatively infrequent, and concentrations in excess of 2000 ppmv were seldom.

Returning to Figure 6, The relative humidity in the cabin was above 50% at the start of the flight, but dropped below 10% at cruise altitude. These measurements suggested conditions on this flight that probably do not represent the optimal comfort range for occupants of other indoor environments (as defined for example in ref.3), but there isn't anything here that is of concern with regard to the health and safety of passengers or crew. It should be noted here, however, that the primary function of the environmental control system is to preserve the lives of passengers and crew in uninhabitable environment. Comfort control is an important, but nonetheless secondary, concern.

Spot measurements of cabin environmental conditions at cruise altitude showed a degree of variation across the cabin, particularly in the largest cabins, as might be expected. Table 1 shows measurements traversing the cabin at cruise altitude on a B747 flight.

Table 1: Longitudinal traverse of cabin conditions at cruise altitude

Row	T <sub>a</sub> (°C)	RH (%)	CO <sub>2</sub> (ppmv)	v <sub>a</sub> (m/s)
14	23.5	4.6	967	0.17
20	25.8	4.5	811	0.16
34	24.6	7.7	1123	0.30
46	26.6	8.7	1306	0.33
63	25.8	4.7	985	0.17

T<sub>a</sub> is the air temperature, RH is relative humidity and v<sub>a</sub> is the magnitude of the air velocity in the aisle. We see that in Row 46, in the economy section, the air temperature and CO<sub>2</sub> concentration are highest. On the other hand this section, which had the highest density of passengers, also had the least dry air.

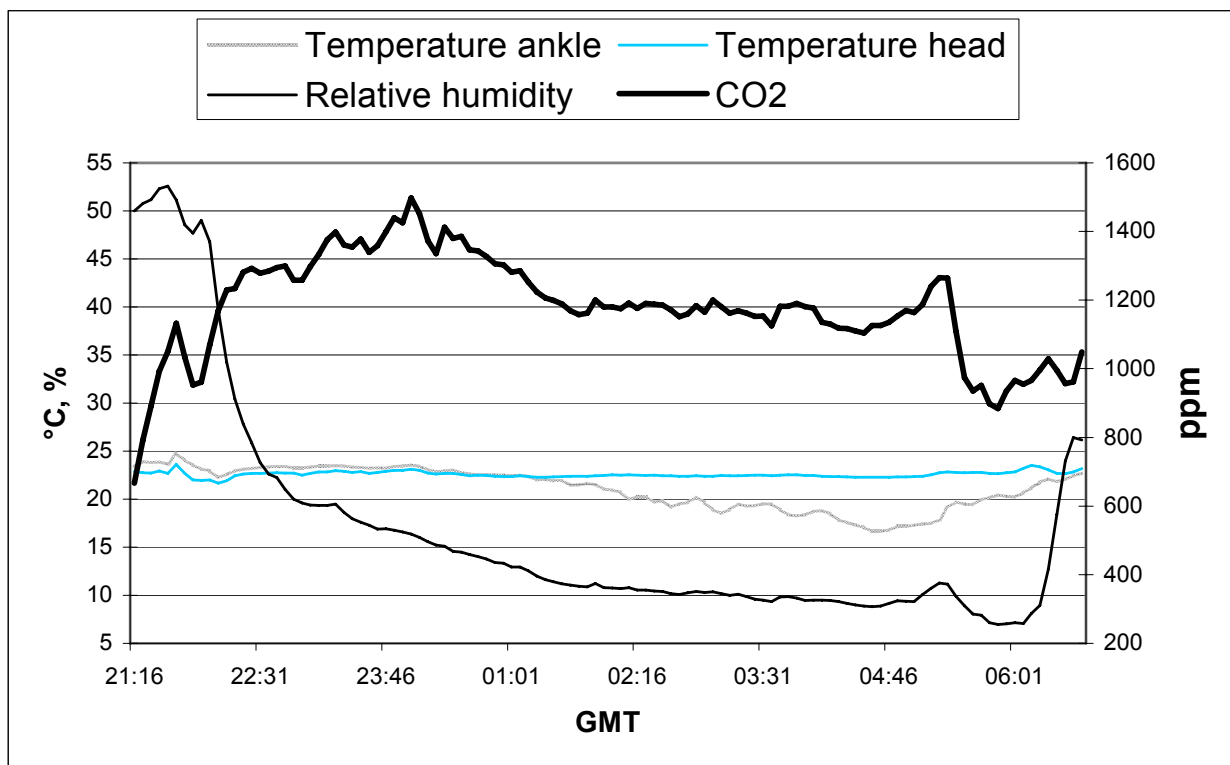

Figure 6 : Gate-to-gate head and ankle temperature, relative humidity and CO<sub>2</sub> concentration at a seat on a typical monitored flight.

Table 2: Summary of questionnaire results regarding cabin crews' perception of cabin environment

Question	Extreme (rating 1)	Average score	Extreme (rating 7)	N
Temperature	Too hot	3.78	Too cold	292
Air movement	Too still	3.75	Too draughty at head height	288
Air movement	Too still	3.76	Too draughty at foot height	278
Air quality	Dry	2.07	Humid	296
Control over temperature	Not at all	3.40	Full control	293
Control over ventilation	Not at all	2.07	Full control	292
Temperature	Stable	3.95	Varies during the flight	288
Temperature	Satisfactory	3.75	Unsatisfactory	282
Air quality	Fresh	4.80	Stuffy	287
Air quality	Odourless	4.04	Smelly	289
Air quality	Satisfactory	4.40	Unsatisfactory	291
Lighting	Satisfactory	2.61	Unsatisfactory	298
Noise	Satisfactory	4.15	Unsatisfactory	299
Overall comfort	Satisfactory	3.73	Unsatisfactory	297

## 5 Questionnaire results from CabinAir

Questionnaires were filled out only by cabin crew during monitored flights. The project had initially intended for passengers to fill out questionnaires as well, but this proved to be impossible in the aftermath of September 11<sup>th</sup> due to economic constraints on the part of the participating airlines. The monitoring flights were carried out in the winter and spring of 2002.

The questionnaire included questions about environmental conditions including ratings of temperature, air movement, air quality, lighting, noise and overall comfort.

In addition there were questions on the perceived degree of control of temperature and ventilation in the cabin. In total 309 questionnaires were received. A summary of the results is shown in Table 2. Questions were answered on a scale of 1 to 7, with the extremes for each question listed in the table. We see that, with the exception of a perception of dryness the cabin crew were largely neutral in their assessment of the temperature, air movement air quality and overall comfort in the passenger cabin. Interestingly, lighting received a positive score. In addition, 'Control over ventilation' received a poor score. This is not surprising as cabin ventilation is controlled automatically based on settings given by the flight crew.

## 6 Implications of results from CabinAir monitoring programme

The discussion above shows that the ventilation system for a modern commercial jet is extremely complex. On the other hand, this complexity doesn't extend to the level of providing any appreciable degree of local control of airflows and temperatures (except for personal air outlets that are an optional item on most aircraft) in the passenger cabin. Other studies have shown that local control makes people feel better about their indoor environment. Means of achieving local control of cabin ventilation are an important proprietary output of Work Package 4 of CabinAir.

Probably the most thought provoking result from the monitoring program is that even though the (bioeffluent generated) carbon dioxide concentration in the cabin or areas of the cabin on monitored flights often exceeded 1000 ppmv, responding cabin crew members as a group did not appear to be dissatisfied with the work environment.

## 7 References

- [1] European Aviation Safety Agency (EASA), *Certification Specifications For Large Aeroplanes CS 25, Book 1 – Airworthiness Code*; §25.831 'Ventilation', 2003 <http://www.easa.eu.int/>
- [2] Federal Aviation Administration (FAA), *Federal Aviation Regulations (FAR)*, §25.831 'Ventilation', last amended 1997 <http://www.faa.gov/>
- [3] ISO 7730:1994: *Moderate thermal environments – Determination of the PMV and PPD indices and specification of the conditions for thermal comfort*, International Organization for Standardization, Geneva.
- [4] Lannaud, Par Jean ; 'Aéroports : Préconditionnement d'air des avions au sol', *Chauffage Ventilation Conditionnement d'Air (CVC)* no. 830/831, sept./oct. 2004, <http://www.aicvf.com/>
- [5] [http://en.wikipedia.org/wiki/Auxiliary\\_power\\_unit](http://en.wikipedia.org/wiki/Auxiliary_power_unit)
- [6] <http://projects.bre.co.uk/envdiv/cabinair/>

**The CabinAir project** [ref.6] was a 3-year research project in the EU's 5th Framework Program. The project was led by BRE in the UK, with consortium members from five research institutions, three airlines, two aircraft manufacturers, three aircraft parts & systems manufacturers, and a civil aviation authority. The project was divided into five work packages, the first of which was centred on a monitoring program consisting of measurements and questionnaires on 50 commercial airline flights. The overall goal of this Work Package 1 (WP1) was to identify current and best practice, as well as problem areas to inform the developments in the later work packages. Work Packages 2-4 involved technological improvements in aircraft environmental control systems (ECS), filtration systems and air distribution systems. The 5th work package involved putting together a prenormative European standard for air quality and comfort in airliner cabins. NBI (now SINTEF) in Norway was responsible for completing the identification of current and best practice and for ensuring that the monitoring programme was carried out correctly. This article focuses on the findings from WP1, and their implications.

---

**The Air Infiltration and Ventilation Centre** was inaugurated through the International Energy Agency and is funded by the following countries: Belgium, Czech Republic, Denmark, France, Greece, Japan, Republic of Korea, Netherlands, Norway and United States of America.

The Air Infiltration and Ventilation Centre provides technical support in air infiltration and ventilation research and application. The aim is to promote the understanding of the complex behaviour of the air flow in buildings and to advance the effective application of associated energy saving measures in the design of new buildings and the improvement of the existing building stock.