

EFFECTIVE VENTILATION

9th AIVC Conference, Gent, Belgium
12-15 September, 1988

Poster 19

FLOW CONDITIONS IN A MECHANICALLY VENTILATED ROOM WITH
A CONVECTIVE HEAT SOURCE

PER HEISELBERG, PETER V. NIELSEN

University of Aalborg,
Sohngårdsholmsvej 57, DK-9000 Aalborg, Denmark

SYNOPSIS

The ventilation of a test room ($L \times W \times H = 5.4 \times 3.6 \times 2.4$ m) with a wall mounted heat source is investigated for two different air terminal devices.

The properties of each air terminal device are described by measuring the velocity decay of the primary wall jet below the ceiling.

The velocity distribution in the plume above the heat source has been measured at different heat loads as a function of the distance to the wall and the distance to the heat source.

The measurements have led to an estimate of the maximum velocity in the plume and of the volume flow rate as a function of the heat load and the distance to the heat source.

In order to find the influence of the convective heat source on the flow conditions in the room, the velocity distribution in the occupied zone and the normalized concentration distribution along a vertical line through the middle of the room has been determined as a function of the specific flow rate and the heat load.

The convective heat source is found to have significant influence on the flow conditions in the room. This paper shows lower velocities in the occupied zone and a more uniform concentration distribution in the room.

1. INTRODUCTION

In many buildings mechanical ventilation is combined with convective heating and/or cooling. The purpose of the ventilation system is therefore only to supply the building with fresh air (outdoor air).

When designing the system, it is normally assumed that the room temperature is constant, that the convective source does not affect the flow conditions in the room and that the air supply is isothermal.

This paper deals with the flow conditions in a mechanically ventilated room with a convective heat source. The mean room temperature is kept constant in the experiments with ventilation and thermal load and at the same level as in the experiments without ventilation. The heat loss by ventilation is therefore always zero and not dependent on volumetric flow rate and heat load.

The paper is a continuation of the isothermal measurements given earlier by Heiselberg and Nielsen¹.

The room is placed in a laboratory hall and has the dimensions $L \times W \times H = 5.4 \times 3.6 \times 2.4$ m. Experiments are made with two different supply openings and both of them are placed close to the ceiling at one of the end walls. Two return openings are located at the other end wall 0.7 m above the floor. The heater is placed at the same wall as the supply openings with the top 0.7 m above the floor. The situation is illustrated in figure 1.

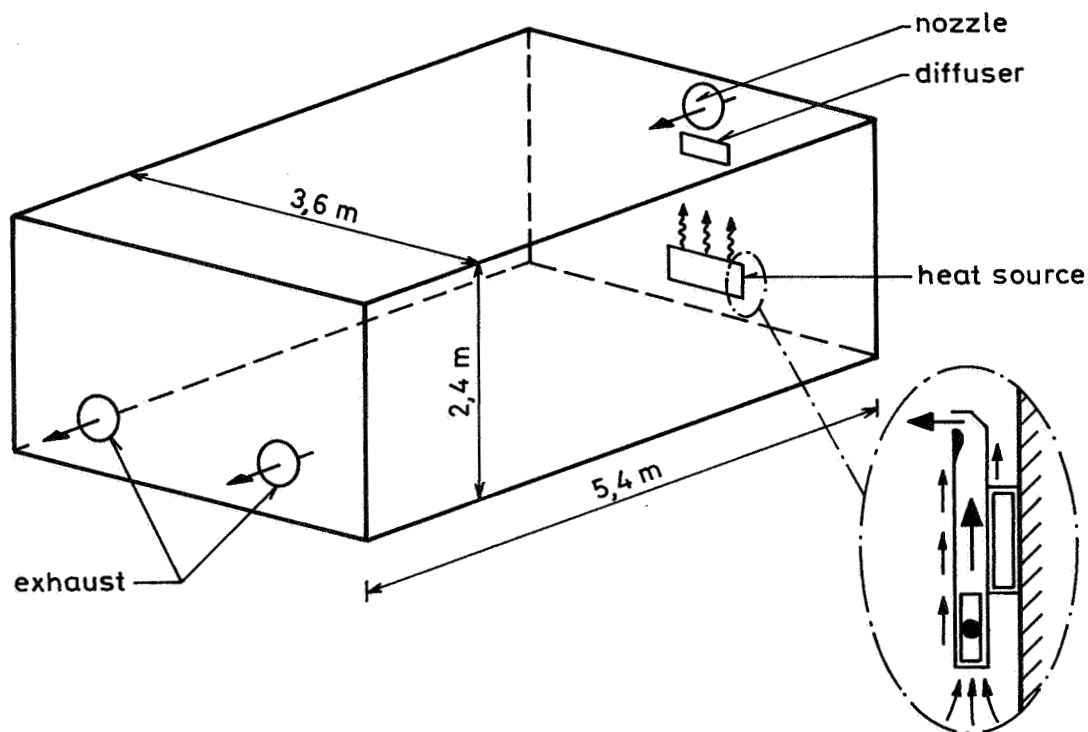

Figure 1. Location of supply-, return openings and convective heat source in the test room.

The two different supply openings are a nozzle (A) with a diameter of 132 mm and a diffuser PVD-10 (D) from STIFAB.

The convective heat source is an electrically heated radiator consisting of a heating element with fins built into a metal cabinet as shown in figure 1.

The heater is mounted on the wall. The main flow goes through the heater and leaves it horizontally from the front.

2. VELOCITY MEASUREMENTS

The velocity decay of the primary jet is measured for both air terminal devices. The result gives a good description of the properties of the air terminal devices and makes it possible to determine the maximum permissible supply velocities and volumetric flow rates based on the throw of the jets.

The velocity distribution in the middle of the hot plume is measured to find the maximum velocity and volume flow as a function of the power supplied and the distance to the heat source.

The maximum velocity of the recirculating flow is measured as a function of the volumetric flow rate and the power supply to the heat source. Applying these results and the comfort requirements by Fanger and Christensen² to the air velocity in the occupied zone, it is possible to find the maximum supply velocity or volumetric flow rate based on comfort requirements.

2.1 Wall jet conditions

For a three-dimensional wall jet the expression for the maximum velocity of the primary jet as a function of the distance to the supply opening is given by

$$\frac{V_x}{V_0} = K_a \frac{\sqrt{a_0}}{x+x_0} \quad (1)$$

The K_a -value, the effective supply area, a_0 , and the distance to virtual origin, x_0 , are found for both air terminal devices (A) and (D). The result is shown in figure 2.

AIR TERMINAL DEVICE	DISTANCE TO CEILING (m)	K_a	a_0 (10^{-3} m^2)	x_0 (m)
A	0.067	9.5	14.0	0.55
D	0.300	1.9	7.3	0.14

Figure 2. K_a -value, effective supply area, a_0 , and distance to virtual origin, x_0 , are given for both air terminal devices.

Figure 2 shows that the K_a -values differ with the factor 5. As expected, the nozzle has the highest value and the diffuser the lowest. The K_a -value for diffuser D is a typical value for a commercial diffuser design.

2.2 Air exchange at constant throw

The maximum permissible supply velocity V_o is found for each air terminal device for a throw which is equal to the room length, L , and the corresponding terminal velocity equal to 0.25 m/s. The result is shown in figure 3 together with the air supply flow rate and the specific flow rate.

The specific flow rate is defined as

$$n = \frac{q_o}{LWH} \quad (h^{-1}) \quad (2)$$

where q_o is the air supply flow rate.

AIR TERMINAL DEVICE	V_o m/s	q_o m ³ /h	n h ⁻¹
A	1.3	67	1.4
D	8.1	213	4.6

Figure 3. Maximum permissible supply velocity, air supply flow rate and specific flow rate for each air terminal device for a throw which is equal to the room length.

Figure 3 shows a significant difference between the maximum permissible volumetric flow rates for the two air terminal devices.

2.3 Convective flow above the heat source

The air velocities in the convective plume above the heat source are measured as functions of the distance from the top of the source, the distance to the wall and of the power supplied. Four distances from the heat source have been measured, namely 0.11 m, 0.70 m, 1.28 m and 1.55 m, and the power supplied to the source was 256 W/m, 513 W/m, 769 W/m and 1026 W/m, respectively.

In figure 4 the velocities are shown as functions of the distance to the wall for 4 distances from the top of the heat source and a power supply of 256 W/m.

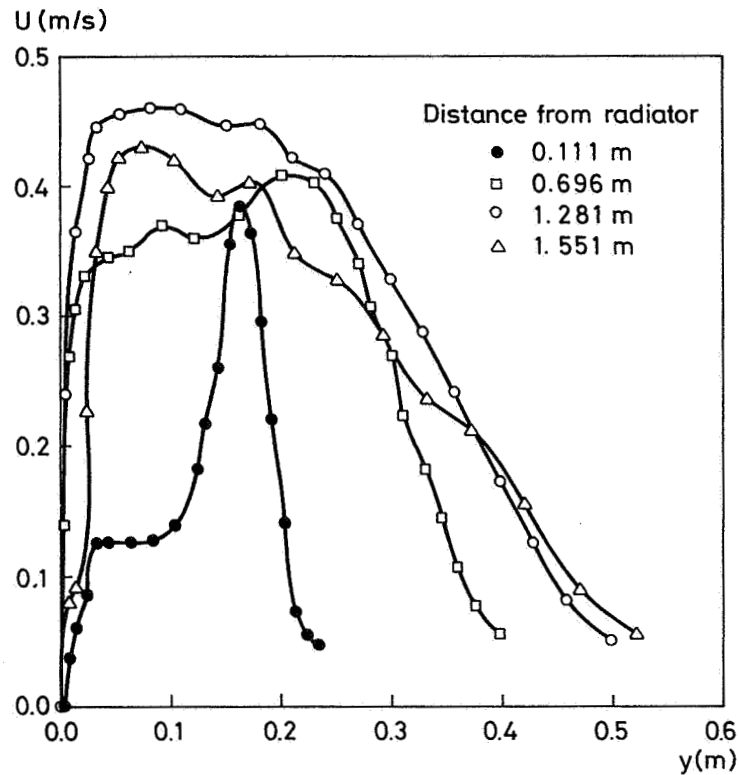

Figure 4. Air velocities in the convective plume above the heat source as functions of the distance to the wall. The measurements have been made at 4 distances from the top of the source and at a power supply of 256 W/m.

Near the heat source the velocities are low close to the wall and high over a small range about 0.15 m from the wall. This is due to the design and the mounting of the heater. The heater is placed 0.05 m from the wall and the main plume leaves the heat source horizontally at the front. Bouyance changes the flow to a vertical plume and the plume turns into a wall plume at some distance from the heat source.

The relation between the maximum velocity in the convective plume, the distance from the top of the heater and the heat load may be expressed by

$$U_{\max} = 0.085 Q_C^{0.3} y^{0.06} \text{ (m/s)} \quad (3)$$

where

Q_C is the convective heat load per length (W/m)

y is the distance from the top of the heater (m)

The volume flow in the convective plume can be calculated from the measured velocity distribution in the plume by integrating from the wall to δ , the distance where the velocity is zero. The volume flow is calculated as:

$$q_y = \ell \int_0^{\delta} U dx \quad (\text{m}^3/\text{s}) \quad (4)$$

where

q_y is the volume flow in the convective plume

ℓ is the length of the heater

δ is the width of the plume

U is the measured velocity

The volume flow in the plume depends on heat load and distance from the heater.

$$q_y = 0.016 Q_C^{2/5} y^{1/2} \ell \quad (\text{m}^3/\text{s}) \quad (5)$$

The supply openings are located 1.5 m above the heater and at this height the volume flow varies between 0.14 m³/s and 0.24 m³/s corresponding to a specific flow rate of 11 - 19 h⁻¹. This volume flow is very large compared to the volume flow of fresh air (1 - 5 h⁻¹).

2.4 Room air velocities

The air velocities in the occupied zone are measured at 5 different specific flow rates and at 5 different heat loads for both air terminal devices. In figure 5 the velocity 0.1 m above the floor is shown for the nozzle (A) under isothermal conditions and with a heat load of 800 W.

The result of the velocity measurements in the occupied zone contains several characteristics.

At isothermal conditions and at specific flow rates exceeding 2 - 3 h⁻¹ there is a linear correlation between air velocity and specific flow rate. This means that the flow has a fully developed turbulent level in the room and that the normalized values are independent of the velocity, see Nielsen³.

The same correlation does not appear with heat load in the room. The velocities are considerably lower with heat

load in the room than under isothermal conditions. The supply air is mixed with air from the hot plume above the heat source. Totally this gives a plume or jet which is warmer than the room air. Due to buoyancy the velocity in the downward flow at the opposite wall will decrease more rapidly than under isothermal conditions giving lower velocities in the occupied zone.

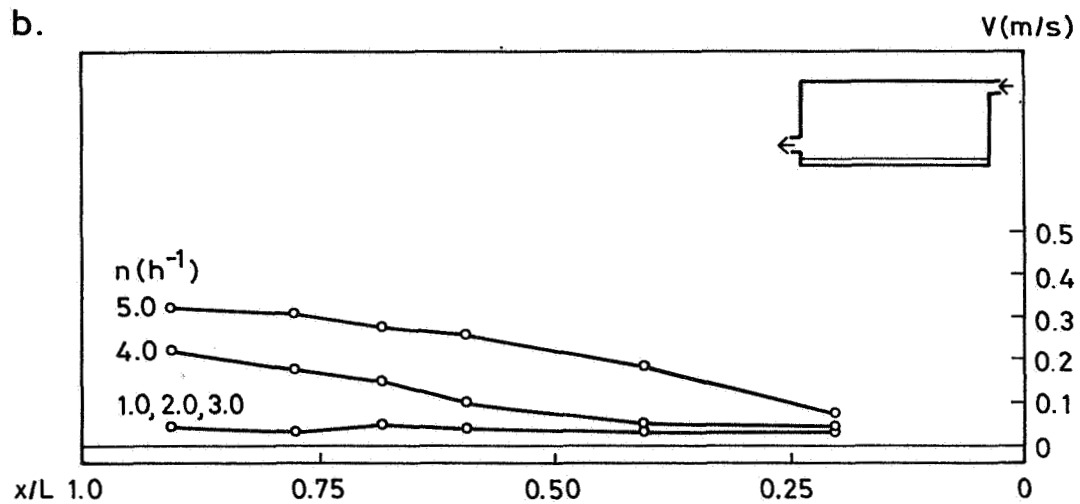
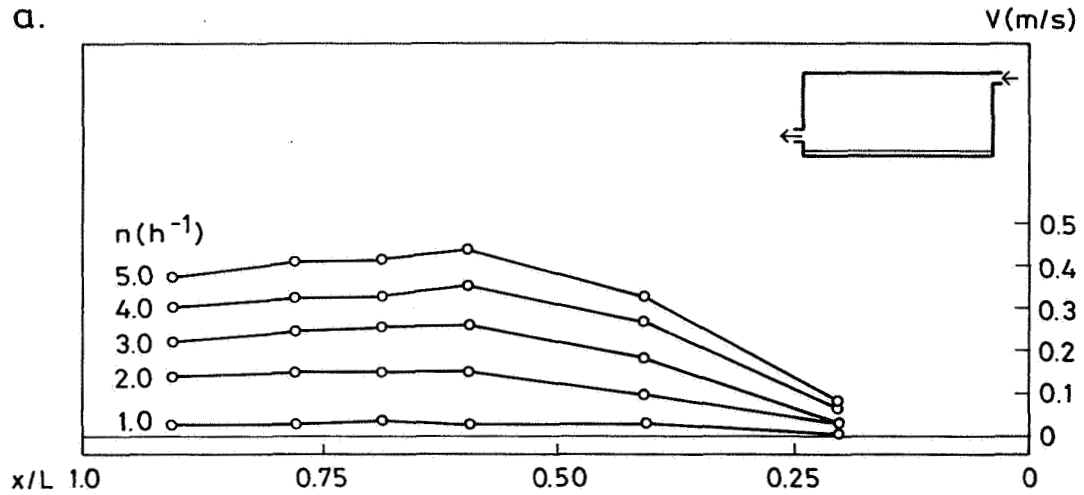

Figure 5. Air velocities in the occupied zone at 5 different specific flow rates for the nozzle (A) measured 0.1 m above the floor under: a) isothermal conditions, and b) with a heat load of 800 W in the room.

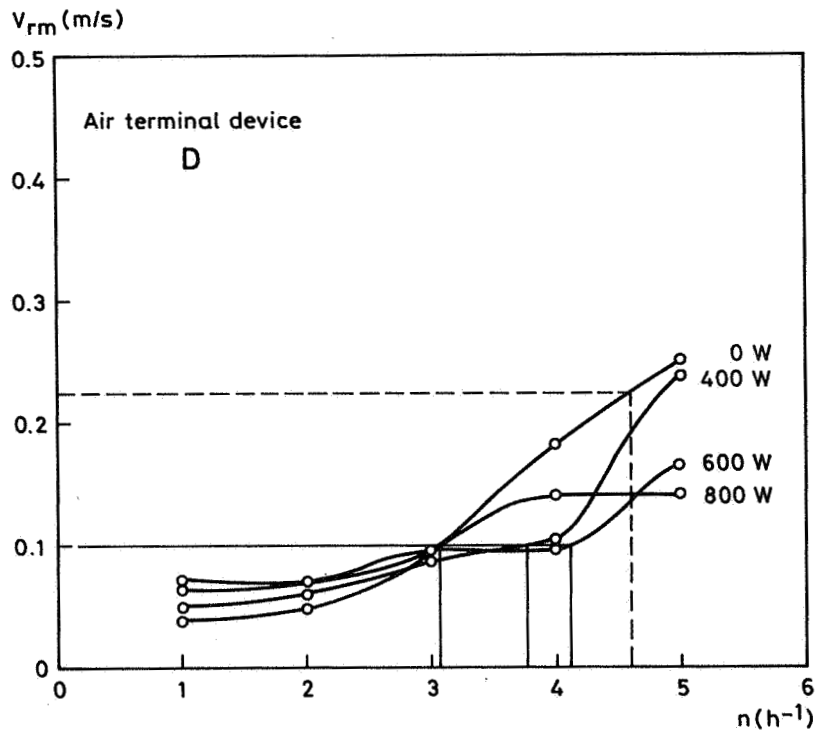
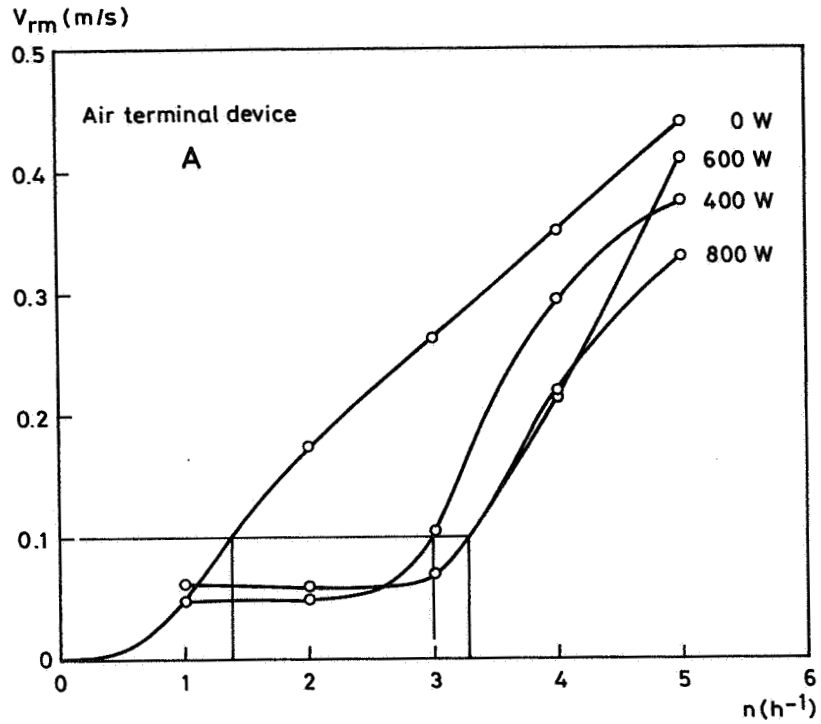

Figure 6. The maximum air velocity in the occupied zone as a function of the specific flow rate and the heat load for air terminal devices (A) and (D).

The maximum air velocity in the occupied zone cannot be completely determined from the measurements. However, it is estimated from the measured velocities at 18 points that the correct value is not considerably higher than the measured value. Therefore, in the following the maximum air velocity in the occupied zone is assumed to be equal to the maximum measured air velocity.

In figure 6 the maximum measured air velocity is shown as a function of the specific flow rate and the heat load for both air terminal devices.

As expected figure 6 shows that the maximum velocity in the occupied zone is much higher for ventilation with the nozzle than for ventilation with the diffuser at the same specific flow rate. This means that the diffuser (D) allows the highest specific flow rate in the room at the same velocity level in the occupied zone.

Figure 6 also shows, especially for the nozzle (A), that the maximum velocity in the occupied zone is much lower with heat load in the room than under isothermal conditions. The difference in velocity decreases at increasing specific flow rate and decreasing heat load.

2.5 Comfort demands

Determination of the comfort limit for air velocity in the occupied zone in a room depends on the acceptable level of discomfort. In an ordinary office a dissatisfaction rate of 10% is acceptable. According to Fanger and Christensen² the comfort limit for air velocity should in this case be $V_{rm} = 0.1$ m/s. This value is adequate within the normal temperature range in ventilated work rooms.

The maximum specific flow rate can be found from the comfort limit and figure 6. The results are shown for both air terminal devices in figure 7.

AIR TERMINAL DEVICE	ISOTH. COND.		THERM. COND.	
	$n(h^{-1})$	$q_o(m^3/h)$	$n(h^{-1})$	$q_o(m^3/h)$
A	1.4	66	3.0-3.3	140-154
D	3.1	145	3.1-4.1	145-191

Figure 7. Maximum specific flow rate and air supply flow rate for air terminal devices (A) and (D) for $V_{rm} = 0.1$ m/s.

The result from figure 3 is included in figure 6 together with the comfort requirements. Apparently a design with a throw equal to the room length functions satisfactorily for the nozzle under isothermal conditions. It is further shown that the non-isothermal conditions (at the given location of heat source and supply temperature equal to return temperature) allows a specific flow rate from the nozzle (A) which is high compared to the value found for the throw equal to room length.

Diffuser D and a throw equal to the room length gives a maximum air velocity of 0.23 m/s in the occupied zone. This corresponds to a dissatisfaction rate of 40% which is clearly unacceptable. The reason for the failure of the simple design method may be that the wall jet from the diffuser spreads quickly and occupies a large area of the room which increases the velocity level in the return flow.

The need for fresh air in the room depends on its use. If the room is used as a conference room with space enough for 6 - 8 persons, the necessary specific flow rate of fresh air to the room will be either 5.4 h^{-1} or 3.7 h^{-1} dependent on whether or not smoking is allowed*. It will not be possible to supply the room with fresh air through the nozzle in this case, if the comfort demands are to be fulfilled.

3. CONCENTRATION MEASUREMENTS

The concentration measurements were performed to determine the distribution of contamination in the room under different circumstances. The measurements are performed under stationary contaminant, air and temperature distribution conditions. The measuring points are evenly distributed along a vertical line through the middle of the room. The tracer gas is supplied through a point source (diameter 30 mm) placed 1.1 m above the floor in the middle of the room. For both air terminal devices the room has been ventilated with specific flow rates of 1 h^{-1} , 2 h^{-1} and 3 h^{-1} , respectively. The heat load has been varied between 0 W, 400 W and 800 W, respectively.

3.1 Normalized concentration distribution

The concentration measurements are normalized in relation to the concentration m_R in the return opening. A concentration of m/m_R of e.g. 2.0 will indicate that the local concentration is twice as high as the concentration in the return opening

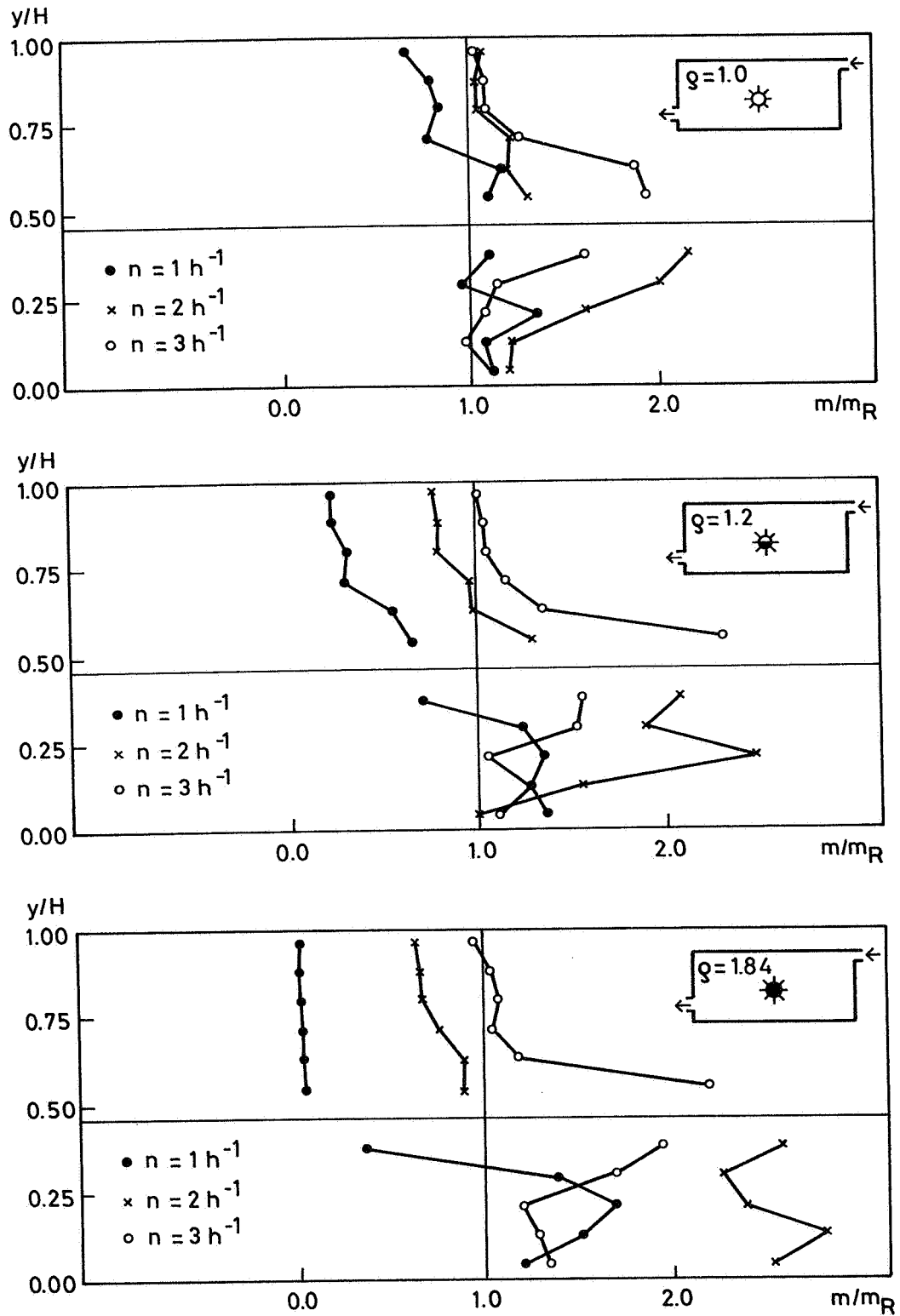

Figure 8. Normalized concentration distribution along a vertical line through the middle of the room for air terminal device (D) under isothermal conditions. Specific flow rates of 1 h^{-1} , 2 h^{-1} and 3 h^{-1} and a tracer gas densities of 1.0 kg/m^3 , 1.2 kg/m^3 and 1.84 kg/m^3 .

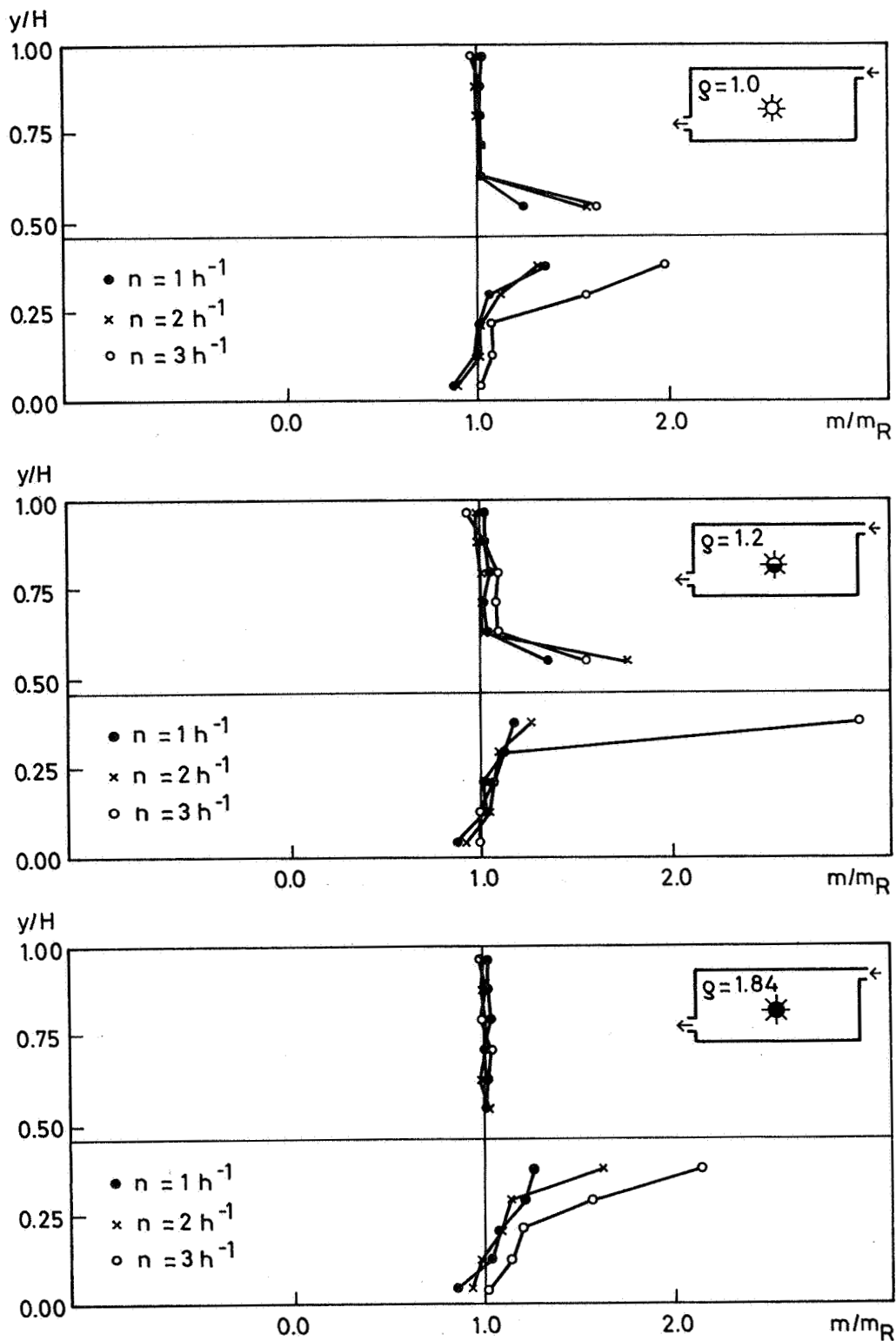

Figure 9. Normalized concentration distribution along a vertical line through the middle of the room for air terminal device (D). Heat load equal to 800 W. Specific flow rates of 1 h^{-1} , 2 h^{-1} and 3 h^{-1} and a tracer gas densities of 1.0 kg/m^3 , 1.2 kg/m^3 and 1.84 kg/m^3 .

The result in figure 8 shows a concentration distribution in the wall jet created by entrainment of the contaminated room air into the primary air. The concentration is highest around and directly below the source. The source is placed in an area of the occupied zone where the air velocity is very low, and the tracer gas will reach a high concentration level before it is entrained and discharged with the other air in the room. Measurements by Oppl⁵ show a similar effect when the source is placed in an area with a low velocity.

With increasing specific flow rate it is seen that the contaminant distribution m/m_R is approximating the distribution under high turbulent flow conditions in the room. It is characteristic of this distribution that it is independent of the specific flow rate, see Nielsen⁶. It is seen that the tracer gas density affects the distribution. Above the source level the highest concentrations were measured by using tracer gas of low density, and the lowest concentrations were measured by using tracer gas of high density. The reverse condition applies below source level. However, the influence decreases at increasing specific flow rate.

The result in figure 9 shows a concentration distribution which is rather independent of specific flow rate and tracer gas density. As under isothermal conditions the concentration is highest around and just below the source. In the rest of the room the concentration level is the same as in the return opening. The distribution may be explained by the large amount of air which is circulated by the convective heat source, and it may also be explained by a slightly increased velocity around the source which is measured in the case of heat load in the room.

4. CONCLUSION

The design of air terminal devices in ventilated rooms with a throw equal to the room length does not always ensure thermal comfort. The air velocity in the occupied zone does not only depend on the proportions of the supply opening but also on the flow conditions in the room.

A convection heat source in the room gives rise to a large internal volume flow in the room and this means an equally distributed concentration m/m_R in the room independent of the specific flow rate.

5. REFERENCES

1. HEISELBERG, P. and NIELSEN, P.V.,
"The contaminant distribution in a ventilated room
with different air terminal devices",
Room Vent 87, Stockholm, June 1987.
2. FANGER, P.O. and CHRISTENSEN, N.K.,
"Perception of draught in ventilated spaces",
Ergonomics, 1986, vol. 29, No. 2, 215-235.
3. NIELSEN, P.V.,
"Flow in air conditioned rooms",
(English translation of Ph.D.-thesis from the tech-
nical University of Denmark, 1974) Danfoss A/S, 1976.
4. "Code of Practice for Ventilation Installation",
Danish standard, DS 447, Dec. 1981.
5. OPPL, L.,
"Luftströmung in gelüfteten Räumen",
Öl- und Gasfeuerung, Nr. 9, 1969.
6. NIELSEN, P.V.,
"Contaminant distribution in industrial areas with
forced ventilation and two-dimensional flow",
IIR-Joint Meeting, Commission E1, Essen, Sept. 1981.