

Guide for the Prevention of Microbial Growth in Ventilation Systems

ÉTUDES ET RECHERCHES

Jacques Lavoie
Louis Lazure

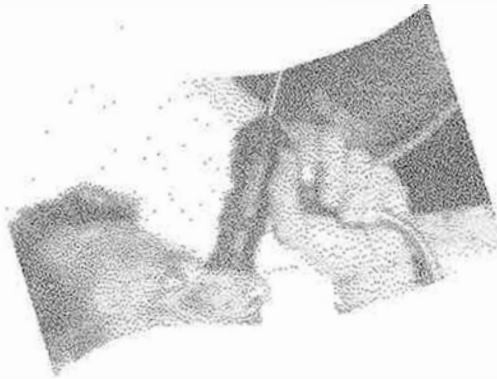

8988

October 1994

RG-089

TECHNICAL GUIDE



IRSST

Institut de recherche
en santé et en sécurité
du travail du Québec

Guide for the Prevention of Microbial Growth in Ventilation Systems

Jacques Lavoie
Louis Lazure
Analytical Support Programme, IRSST

October 1994 RG-089

**ÉTUDES ET
RECHERCHES**

TECHNICAL GUIDE

Research, the key to understanding

The Institut de recherche en santé et en sécurité du travail du Québec (IRSST, Québec Occupational Health and Safety Research Institute) is a scientific research agency committed to the identification and elimination at the source of occupational hazards, and the rehabilitation of workers who have suffered occupational injuries. Financed by the CSST, the Institute conducts, funds, and contracts research aimed at reducing the human and financial cost of occupational accidents and diseases.

Reports describing the results of Institute research are available upon request from the Direction des communications. A news-magazine, *L'IRSST*, is published three times a year and contains articles and accessible summaries of recent research and publications. A list of Institute publications is also available from the address listed below.

Legal Deposit
Bibliothèque nationale du Québec
1994
ISSN: 0820-8395
ISBN: 2-551-13402-1

IRSST - Communication Division
505, de Maisonneuve Blvd., West
Montreal (Quebec)
H3A 3C2
Telephone: (514) 288-1551
Fax : (514) 288-7636

© Institut de recherche en santé
et en sécurité du travail du Québec,
October 1994.

Acknowledgements

The authors would like to thank France C. Lafontaine of the IRSST for the excellent word processing work, as well as Roland Pelletier and François Chamberland of the MUCTC, René Beauchemin of UQAM, Sylvain Dubé, Pierre Bourdeau and Vincent Dilalla of Bell Canada, Charles Prévost of the CSN, Sylvain Allaire of CLSC Haute-Ville, Michel Legris of CLSC-Chutes-de-la-Chaudière-Desjardins, Gilles Paquette of the Institut Armand-Frappier, Michel Bolduc of the CSST and Maurice Beaudet of Beaulier Inc. for their revision work. We would also like to mention the collaboration of Dominique Desjardins and Marjolaine Thibeault of the IRSST, Yves Lacharité of the SIQ, and Serge Rivard of the MUC.

Preface

This guide combines two complementary disciplines, engineering and biology. It will provide people involved from the design to the evaluation to the operational phase of ventilation systems with not only a better understanding of the relationship between operation and the appearance of conditions favorable to the development of microorganisms, but also the means for controlling their growth.

A complete review of pertinent technical information was necessary to produce this document, as well as an analysis of available research reports, and the consultation of publications of various organizations and associations. In total, more than one hundred documents were consulted.

In order to ensure its application, the guide was designed and written in such a way as to illustrate, in the best way possible, situations characteristic of our environment. The photographs, taken during field visits, demonstrate familiar situations. The completed guide was validated by potential users and revised on the basis of their comments. Field checklists have been included in order to make this document easier to use.

Knowledge in this field of expertise is evolving rapidly, and consequently a periodic update is planned.

Table of contents

	pages
INTRODUCTION	IX
1. MICROORGANISMS	1.1
1.1 Viruses	1.3
1.2 Bacteria	1.3
1.2.1 Endotoxins	1.3
1.3 Fungi	1.4
1.3.1 Mycotoxins	1.4
1.4 Protozoa	1.4
1.5 Antigens	1.5
Bibliography on microorganisms	1.7
2. AIR TREATMENT SYSTEMS	2.1
2.1 Components	2.1
2.2 Air conditioning processes	2.2
2.2.1 Cooling and dehumidification	2.4
2.2.2 Heating	2.4
2.2.3 Humidification	2.4
Bibliography on air treatment systems	2.5
3. BIOCONTAMINATION OF COMPONENTS	3.1
3.1 Outdoor air intakes	3.1
3.2 Mixing plenum	3.2
3.3 Filtration unit	3.2
3.4 Heating and cooling coils	3.4
3.5 Humidifiers	3.5
3.5.1 Heated pan humidifiers	3.5
3.5.2 Saturated steam humidifiers	3.7
3.5.3 Atomizing humidifiers	3.8
3.5.4 Spray humidifiers	3.10
3.6 Fans	3.12
3.7 Air supply and return ducts	3.12
3.8 Sound attenuators	3.13
3.9 Diffusers and peripheral units	3.14
3.10 Internal sources	3.14
Bibliography on biocontamination of components	3.16

4. VISUAL INSPECTION AND SAMPLING	4.1
4.1 Visual inspection	4.1
4.2 Sampling of microorganisms	4.4
4.3 Guidelines	4.7
Bibliography on visual inspection and sampling	4.8
5. MAINTENANCE AND CONTROL PROCEDURES	5.1
5.1 Cleaning methods	5.1
5.1.1 Disinfectants	5.1
5.1.2 Vacuuming of dirt	5.3
5.1.3 Other methods	5.5
5.1.4 Work sequence	5.7
5.2 Preventive maintenance program	5.7
Bibliography on maintenance and control procedures	5.12
6. PREVENTIVE MEASURES AND REGULATIONS	6.1
6.1 Outdoor air intakes	6.1
6.2 Mixing plenum	6.2
6.3 Filtration	6.3
6.4 Cooling coil	6.5
6.5 Humidifiers	6.6
6.6 Air supply and return ducts	6.7
6.7 Indoor sources of contamination	6.8
6.7.1 Surface condensation	6.8
6.7.2 Hidden condensation	6.9
6.7.3 Controlling humidity	6.10
Bibliography on preventive measures and regulations	6.11
CONCLUSION	6.12
7. FIGURE : BIUCONTAMINATION OF HEATING, VENTILATING AND AIR-CONDITIONING (HVAC) SYSTEMS	7.1
8. OTHERS	
Copy of Specifications for cleaning of ventilation ducts	
Copies of Inspection checklist	

List of figures

	pages
Figure 1.1: Classification of microbes in the protist kingdom	1.1
Figure 1.2: Typical aerosol particle sizes	1.2
Figure 2.1: Mechanical ventilation system	2.1
Figure 2.2: Psychrometric diagram	2.2
Figure 2.3: Fundamental air-conditioning processes	2.3
Figure 3.1: Outdoor air intake located below ground level	3.1
Figure 3.2: Vitiated air from storage areas	3.2
Figure 3.3: Build-up of debris and rust on the walls of a mixing plenum	3.3
Figure 3.4: Filters damaged by outdoor environmental conditions	3.4
Figure 3.5: Cooling coil drain pan	3.5
Figure 3.6: Diagram of a heated pan humidifier	3.6
Figure 3.7: Heated pan humidifier	3.6
Figure 3.8: Diagram of a dry steam humidifier	3.7
Figure 3.9: Diagram of a self-contained steam humidifier	3.8
Figure 3.10: Self-contained steam humidifier	3.9
Figure 3.11: Diagram of an atomizing humidifier	3.9
Figure 3.12: Diagram of a spray humidifier	3.10
Figure 3.13: Spray humidifier	3.11
Figure 3.14: Build-up of dirt inside the humidifier	3.11
Figure 3.15: Build-up of dirt at the fan	3.12
Figure 3.16: Contaminated acoustic insulation	3.13
Figure 3.17: Obvious mold on a ceiling tile	3.15
Figure 4.1: Rigid endoscope (borescope)	4.1
Figure 4.2: Deterioration of bag filters from friction	4.2
Figure 4.3: Extended surface filter	4.4
Figure 4.4: Panel filter	4.4
Figure 4.5: Sampling and analytical method used at the IRSST	4.5
Figure 5.1: Contact vacuuming	5.4
Figure 5.2: Air washing method	5.5
Figure 5.3: Power brushing method	5.6
Figure 5.4: Cleaning sequence for ventilation system components	5.7
Figure 6.1: Thermal bridge created by a steel beam	6.9
Figure 6.2: Temperature gradient during winter	6.10

List of tables

	pages
Table 1.1: Characteristics of a few common microorganisms	1.6
Table 4.1: Inspection checklist	4.2
Table 4.2: Samplers used in sampling viable bioaerosols	4.6
Table 5.1: Characteristics of some common biocides	5.3
Table 5.2: Specifications for cleaning of ventilation ducts	5.8
Table 6.1: Comparison of filters ratings and applications	6.4

INTRODUCTION

This guide is intended for those involved in ventilation system design, management, maintenance, and evaluation. Its purpose is to define the aspects necessary for anticipating, preventing and controlling conditions promoting microbial growth.

The proposed approach has been developed from information gathered during studies and R&D projects carried out at the IRSST as well as those in the scientific and technical literature.

Chapter 1 briefly presents the microorganisms which could develop in ventilation systems as well as a summary of present knowledge about their health effects. Chapter 2 explains the different components of ventilation systems and their operation. Chapter 3 describes how the microorganisms can disperse and develop in ventilation systems. Chapter 4 describes the procedures for identifying and quantifying problems of microbial growth, while Chapter 5 presents ways of eliminating them. Chapter 6 presents the steps to be taken in preventing their appearance as well as pertinent recommendations and regulations.

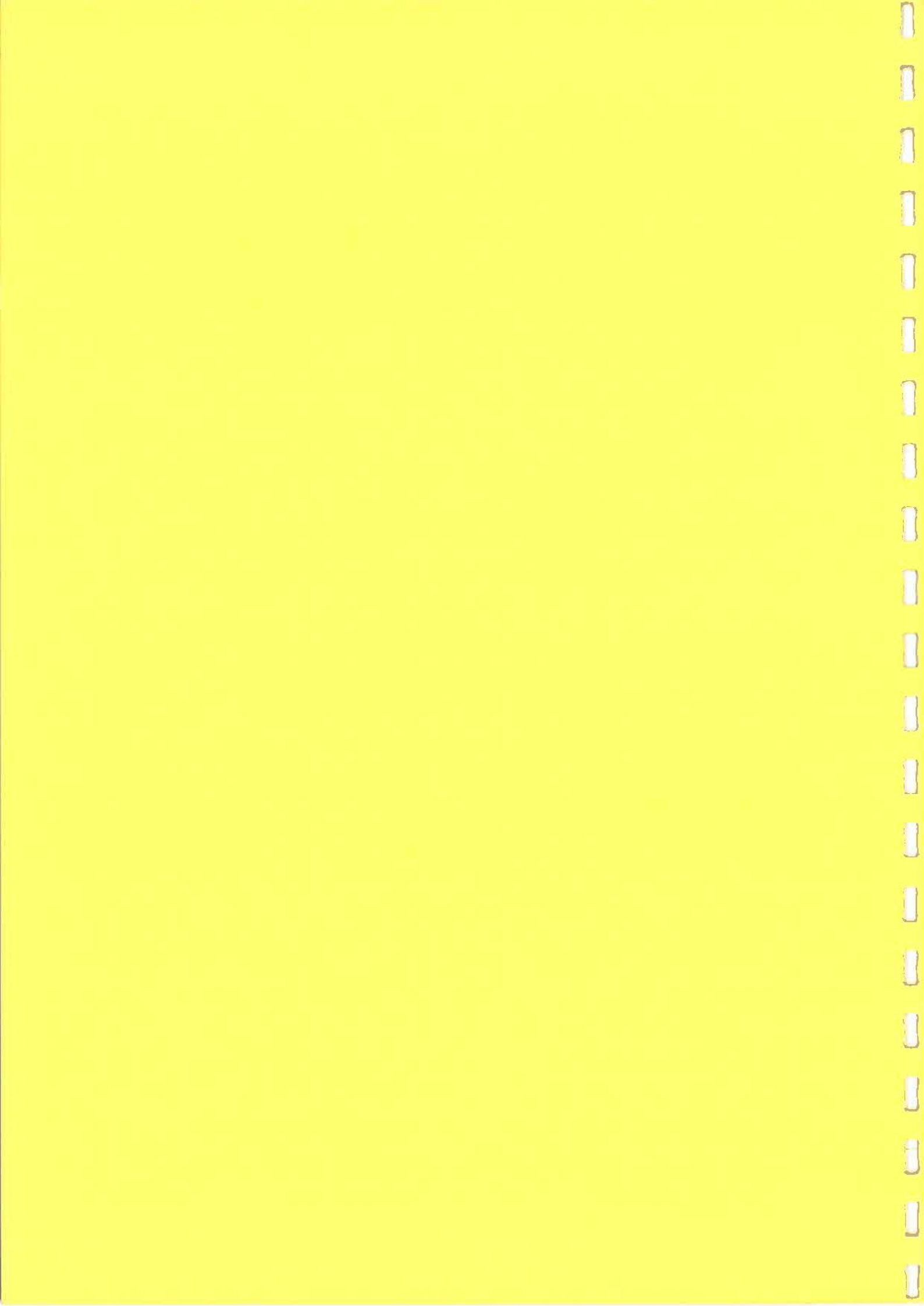

1. MICROORGANISMS

Most of the known microorganisms on this planet are harmless and help in the recycling of organic and inorganic matter in soil and water. Animals have large amounts of bacteria in their intestinal tracts. Several vectors, including animals and people, carry microorganisms into indoor environments. There is therefore a certain normal microflora on inanimate surfaces and in the air which varies with the conditions.

The microorganisms found in buildings or workplaces are viruses, bacteria, and their components, such as endotoxins, fungi and their metabolic products such as mycotoxins, protozoa and antigens. The exposure pathways for microorganisms and their products are: orally, by inhalation, and by penetration through the skin and mucous membranes. Inhalation is the most important one (65 to 75% of infections and allergies). The classification of microorganisms in the protist kingdom (unicellular living organisms) is presented in figure 1.1.

Most microorganisms are complex. For example, fine particles of airborne human skin or droplets from sneezing carry viruses and bacteria. In the same way, a contaminated humidifier may contain different types of bacterial cells and endotoxins, several types of fungal spores, antigens and mycotoxins. Figure 1.2 gives the sizes of various airborne particles, including some microorganisms.

Microorganisms are found in natural reservoirs, generally in outdoor organic matter, and can be amplified and disseminated from these reservoirs towards indoor environments. The mold *Aspergillus flavus* is an example of a saprophytic organism (organism living on organic matter) found in the outdoor environment that can grow in indoor substrates such as carpets, etc. In fact, some bacteria, can reproduce every twenty minutes under ideal laboratory conditions. We generally have no control over most microorganisms in the outdoor environment. However, we can often control their presence indoors.

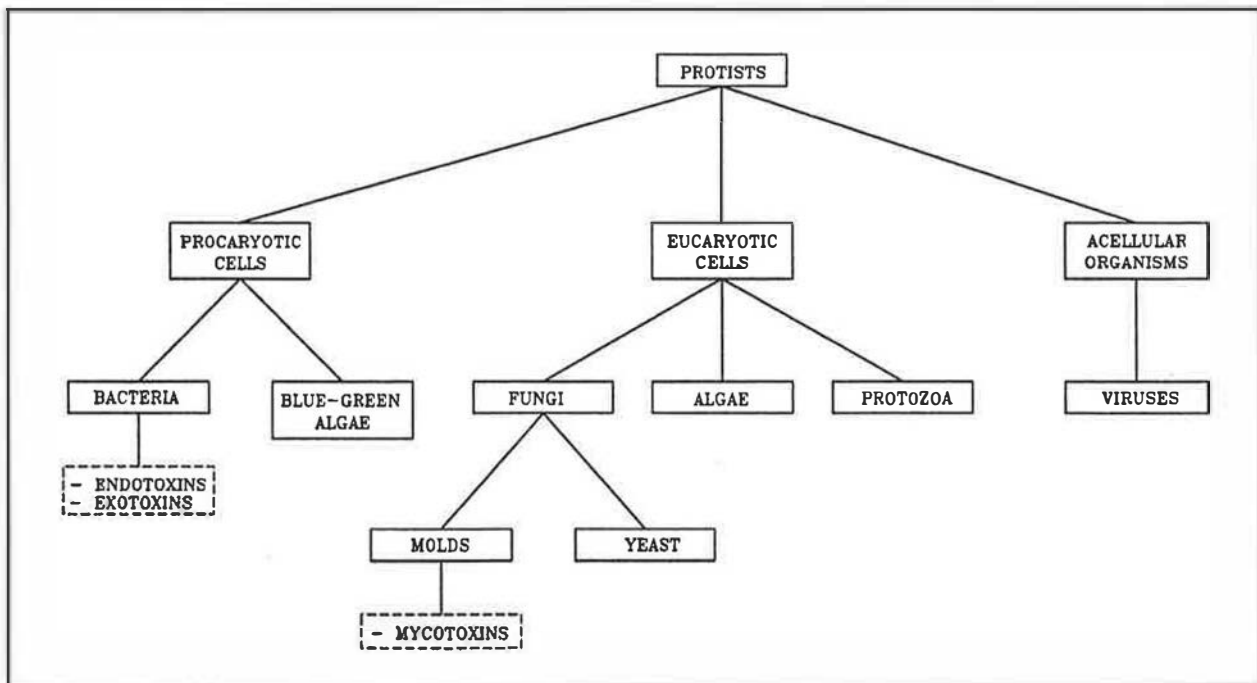

Figure 1.1: Classification of microbes in the protist kingdom

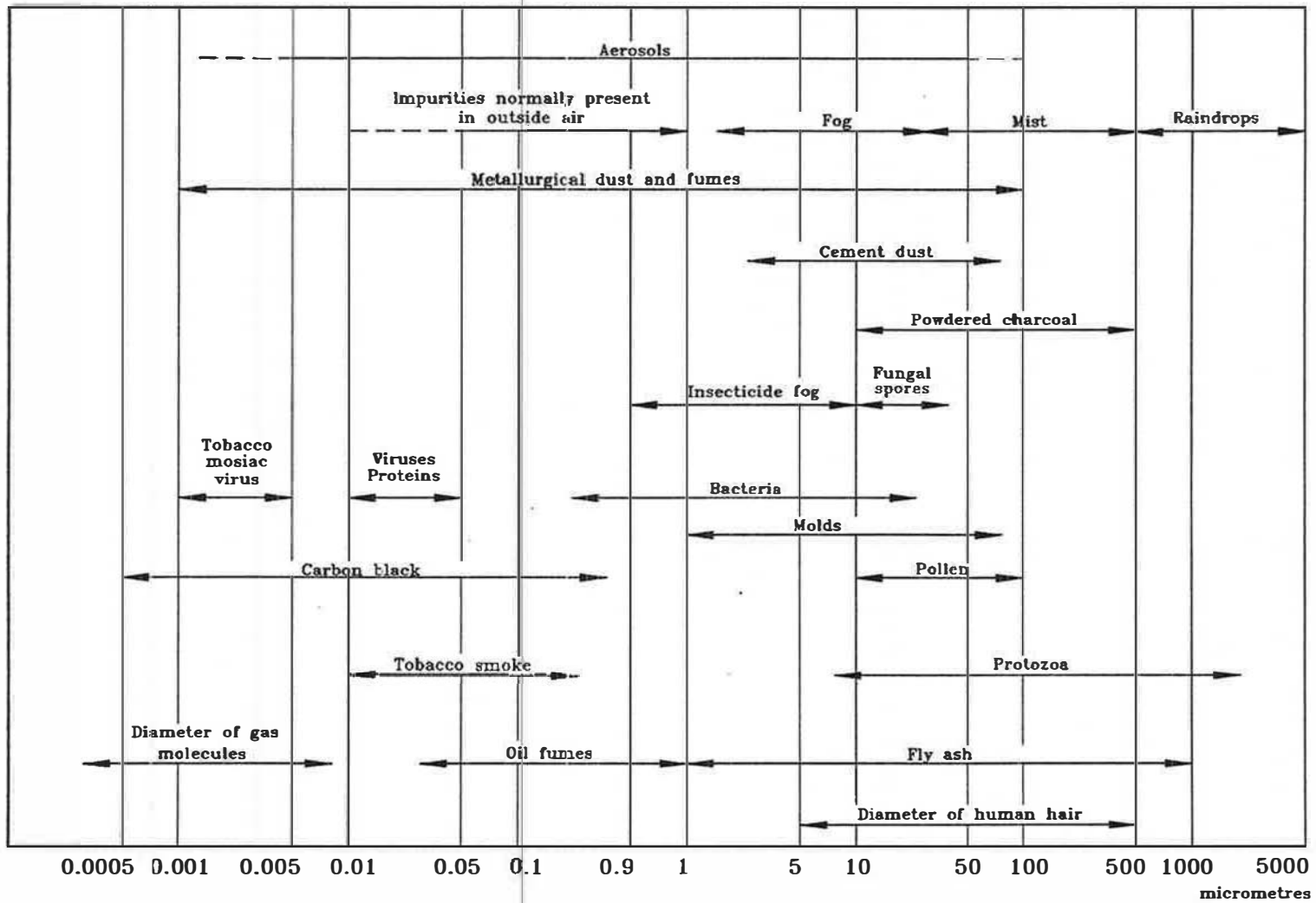

Figure 1.2: Typical aerosol particle sizes

Microorganisms are present in the outdoor air during the entire seasonal growth period. Concentrations fluctuate from 100 colonies or microorganisms per cubic metre of air (colony forming units (CFU/m³)) to 100,000 CFU/m³ of air in urban settings. In other types of environments such as agriculture, concentrations can reach 10⁸ CFU/m³ of air. According to American Conference of Governmental Industrial Hygienists ACGIH (1989), abnormally high concentrations of microorganisms in the indoor air occur when:

- microorganisms in the outdoor air enter buildings (ex.: molds);
- architectural components of buildings become contaminated;
- microorganisms of human or animal origin (ex.: bacteria) accumulate in poorly maintained and poorly ventilated interiors.

1.1 Viruses

Viruses vary in size from 0.004 to 0.1 micrometres (µm). Viruses cannot survive for very long in the environment.

Transmission generally occurs from person to person by droplets or projection. Air sampling is not the commonly used sampling technique. The presence of symptoms or illness in the host is sufficient evidence of the presence of the virus. Furthermore, no virus-related allergies exist. Viruses require a living host cell in order to reproduce, and are rapidly rendered inactive in the ambient environment. They will not reproduce in water or on the organic substrates of ventilation systems, as do bacteria and molds.

1.2 Bacteria

The diameter of bacteria varies from approximately 1 to 20 µm. Bacteria are classified according to their reaction to coloration with crystal violet, their morphology, their oxygen demand, their ability to produce resistant spores, to use specific substrates, to produce specific metabolites, and to cause specific illnesses. Gram-positive bacteria remain colored when stained with crystal violet. Bacteria unable to retain crystal violet are classified as Gram-negative. Pathogenic bacteria (which can cause illnesses in humans) are often classified on the basis of this coloration. Most environments contain a large variety of bacteria. In most cases, there are insufficient bacteria in nature to cause illness. Risks increase only when the pathogenic bacteria are amplified in an environmental reservoir and these organisms or their by-products are suspended and successfully airborne towards the breathing zone. Legionnaire's disease, some pneumonias, and tuberculosis are airborne infectious diseases caused by bacteria (table 1.1). They can also cause humidifier fever and hypersensitivity pneumonitis. With Gram-negative bacteria, the cell has a component that is an endotoxin.

1.2.1 Endotoxins

Endotoxins are a component of the outer membrane of Gram-negative bacteria. Levels of airborne endotoxins have been reported in numerous work environments, including offices and laboratories. The highest reported level (102 µg/m³) has been associated with the handling of contaminated raw cotton and fecal substances such as in agriculture and waste treatment. They can cause fever and malaise, changes in white blood cell counts, and respiratory and gastrointestinal problems (table 1.1).

1.3 Fungi

According to Miller (1992), there are at least 100,000 known species of fungi on the planet. Microscopic fungi include yeasts and molds. Most fungi produce spores (structures whose role is propagation) that are carried by the air. The diameter of these spores varies from approximately 1 to 60 μm . In the process of substrate degradation, fungi produce different metabolic products, some of which can affect the quality of workplace air. Most substances containing carbon (abundant in indoor and outdoor environments) can serve as nutrients for molds. Water intrusion into the indoor environment is the most important factor to be controlled to avoid fungal growth.

Only a few fungi can invade living cells and cause infectious diseases. Such infections generally occur in immunodeficient individuals. However, several molds produce proteins or glycoproteins that are highly antigenic (capable of producing an immune response) and can cause hypersensitivity diseases (allergies) in susceptible individuals. These allergic reactions include rhinitis, allergic asthma and extrinsic allergic alveolitis. Growing molds may also produce several volatile organic compounds. These volatile compounds cause the characteristic moldy odor, among other things.

According to ACGIH (1989), the dose-effect relationship is not known for exposure to molds, and indoor concentrations must therefore be interpreted in relation to reference environments such as the outdoor air.

1.3.1 Mycotoxins

Mycotoxins are substances produced under specific conditions by certain molds. These toxins may cause health problems in humans and animals when ingested. Recently, some studies have reported data on the inhalation of toxinogenic mold spores. Toxinogenic mold spores may contain high concentrations of toxins. For example, spores of *Aspergillus flavus* may contain concentrations greater than 600 parts per million (ppm) of aflatoxin, a human carcinogen. According to Jarvis (1990), the dose-effect relationship has not yet been clearly demonstrated. According to this same author, only workplace exposures to spores of *A. flavus*/*A. parasiticus* constitute definite cases for health problems following exposure by inhalation.

In addition to mycotoxins, fungal spores contain a compound of low molecular weight, beta-1,3-D-glucan. According to Rylander et al. (1992), a dose-effect relationship has been found between beta-1,3-D-glucan levels and symptoms such as headache and skin problems, suffered by occupants of tight buildings. According to Auger et al. (1994), the symptoms or chronic fatigue syndrome in individuals exposed to toxinogenic molds disappear once the sources of growth have been removed.

1.4 Protozoa

Most protozoa are microscopic and consist of single cells. There are thousands of species of protozoa varying in size, structure, morphology and physiologic characteristics. Most are harmless, some are used in biotechnology, and others are capable of causing disease in plants and animals.

These organisms are found in water treatment plants, in thermal effluents, cooling systems, humidifiers, dusts, etc. They can live symbiotically with bacteria (ex. *Legionella*) or molds. In addition to the rare cases of infection in susceptible individuals, exposure to *Naegleria* may also cause hypersensitivity reactions. A study has shown that humidifier fever in office workers was probably caused by the antigens of *Naegleria* aerosolized by a humidifier (ACGIH, (1989)).

1.5 Antigens

Antigens are organic substances capable of producing an immune response in humans. Practically all living organisms contain proteins, glycoproteins or polysaccharides with antigenic potential. This is why we find several microorganisms (bacteria, fungi, protozoa, acarids, etc.) that can have an impact on health via the action of antigens on the immune system.

Allergic diseases depend on the production of antigens which stimulate specific antibodies. An unsensitized individual may become sensitized following one or more contacts with the antigenic substance. After one or more exposures, the human body develops antibodies to this antigen. These antibodies serve as a defense mechanism for future contact with the substance. Once the body has developed antibodies, subsequent contacts will produce responses in the form of inflammation, redness of the eyes, or irritation. Of all the hypersensitivity diseases, only hypersensitivity pneumonitis, allergic asthma, allergic rhinitis and allergic aspergillosis are known as being the result of exposure to airborne antigens. The cause-effect relationship for microbial allergens is well known, but the complete characterization of the dose-response relationship is not.

Ventilation system components, particularly some types of humidifiers, can aerosolize droplets from water reservoirs and therefore are of special interest due to the production of small antigenic particles (smaller than 2-3 μm). Epidemics of hypersensitivity pneumonitis have occurred in individuals when building humidification systems were contaminated. In residences, the most important sources of antigens relating to human health are mites, cats, cockroaches, and molds. All these organisms produce antigens, which can cause allergic asthma and allergic rhinitis. Dust mites (acarids) and their droppings that have accumulated in bedding, furniture or in places where the relative humidity and temperature are favorable, also produce antigens.

A few characteristics of certain bioaerosols are presented in table 1.1.

Table 1.1: Characteristics of a few common microorganisms

(Adapted from ACGIH (1989))

LIVING SOURCE	COMPONENT	EXAMPLE	HEALTH EFFECTS	LIFESTYLE	PRINCIPAL INDOOR SOURCES
Bacteria	Organisms	<i>Legionella</i>	Pneumonia	Facultative parasite	Cooling towers
	Spores	Thermoactinomyces	Hypersensitivity pneumonitis (H.P.)	Saprophytes	Hot water or hot surfaces
	Products	Endotoxin Proteases	Fever Asthma		Water reservoirs Industrial processes
Fungi	Organisms	<i>Sporobolomyces</i>	H.P.	Saprophytes	Damp surfaces
	Spores	<i>Alternaria</i>	Asthma, rhinitis	Saprophytes	Outdoor air
	Spores	<i>Histoplasma</i>	Infections	Facultative parasite	Birds
	Antigens	Glycoproteins	Asthma, rhinitis		Outdoor air
	Toxins	Aflatoxins	Cancer		Damp surfaces
	Volatiles	Aldehydes	Irritants		Damp surfaces
Protozoa	Organisms	<i>Naegleria</i>	Infection	Facultative parasite	Water reservoirs
	Antigens	<i>Acanthamoeba</i>	H.P.		Water reservoirs
Viruses	Organisms	Influenza	Infection	Obligate parasite	Water reservoirs
Algae	Organisms	<i>Chlorococcus</i>	Asthma, rhinitis	Autotrophic	Outdoor air
Green plants	Pollen	<i>Ambrosia</i>	Asthma, rhinitis	Autotrophic	Outdoor air
Arthropods	Feces	Mites	Asthma, rhinitis	Phagotrophic	Dusts
Mammals	Skin scales	Horses	Asthma, rhinitis	Phagotrophic	Horses
	Saliva	Cats	Asthma, rhinitis	Phagotrophic	Cats

Bibliography on microorganisms

ACGIH.: Guidelines for the Assessment of Bioaerosols in the Indoor Environment. Cincinnati, Ohio, 1989.

Ager, B.P., Tickner, J.A.: The Control of Microbiological Hazards Associated with Air-Conditioning and Ventilation Systems. Ann. Occup. Hyg. 27(4):341, 1983.

American Public Health Association.: Control of Communicable Diseases in Man. Abram S. Benenson editor, Washington, D.C., 5th ed., 485 p., 1985.

Auger, P.L., Gourdeau, P., Miller, J.D.: Clinical Experience with Patients Suffering from a Chronic Fatigue-Like Syndrome and Repeated Upper Respiratory Infections in Relation to Airborne Molds. Am. Journ. Ind. Medicine 25:41, 1994.

Brief, R.S., Bernath, T.: Indoor Pollution. Guidelines for Prevention and Control of Microbiological Respiratory Hazards Associated with Air Conditioning and Ventilation Systems. Appl. Ind. Hyg. (3)4:5, 1988.

Burge, H.A.: Approaches to the Control of Indoor Microbial Contamination. Proceedings of the ASHRAE Conference, May 18-20, Arlington, Virginia, pp. 33-37, 1987.

Edwards, J.H.: Microbial and Immunological Investigations and Remedial Action after an Outbreak of Humidifier Fever. Br. J. Ind. Med. 37:55, 1980.

Fink, J.: Hypersensitivity Pneumonitis. In: Allergy. Principles and Practice. Vol.1, E. Middleton, C. Reed, E. Ellis, Eds., C.V. Mosby, St. Louis, MO 1983.

Friedman, S. et al.: Pontiac Fever Outbreak Associated with a Cooling Tower. Am. J. Public Health 77:568, 1987.

Haug R.T.: The Practical Handbook of Compost Engineering. Lewis Publishers, Ann Arbor, 717 pages, 1993.

Health and Welfare Canada: Significance of Fungi in Indoor Air: Report of a Working Group. Working Group on Fungi and Indoor Air. Canadian Public Health Association, March/April 1987, 16 pages.

Hodgson, M.J., Morey, P.R., Simon, J.S. et al.: An Outbreak of Recurrent Acute and Chronic Hypersensitivity Pneumonitis in Office Workers. Am. J. Epidemiol. 125(4):631, 1987.

Institute of Medicine of the US National Academy of Sciences.: Indoor Allergens: Assessing and Controlling Adverse Health Effects. National Academy Press, Washington, DC, 308 p., 1993.

Ishizaka, K., Ishizaka, T.: Immunology of IgE-mediated Hypersensitivity. In: Allergy. Principles and Practice. Vol.1, E. Middleton, C. Reed, E. Ellis, Eds, C.V. Mosby, St. Louis, MO, 1983.

Jarvis, B.J.: Mycotoxins and Indoor Air Quality. in: Biological Contaminants in Indoor Environments, Morey, Feely and Otten editors, ASTM STP 1071, Philadelphia, PA, 244 p., 1990.

Kaufmann, A.F. et al.: Pontiac Fever: Isolation of the Etiologic Agent (*Legionella pneumophila*) and Demonstration of its Mode of Transmission. Am. J. Epidemiol. 114:337, 1981.

Loyd, S.: L'hygiène dans les systèmes de ventilation. Compte-rendu. Note technique TN 18/92, The Building Services Research and Information Association, United Kingdom, 31 p., 1992.

Miller, J.D.: Fungi as Contaminants in Indoor Air. Atmospheric Environment 26A(12):2163, 1992.

Miller, J.D.: Microbial Contamination of Indoor Air. Proceedings of the 5th International Jacques Cartier Conference, pp. 1-11, Montréal, Canada, 1992.

Moodward, E.D. et al.: Outbreak of Hypersensitivity Pneumonitis in an Industrial Setting. JAMA 259(13):1965, 1988.

Morey, P.R., Hodgson, M.J., Sorenson, W.J., et al.: Environmental Studies in Moldy Office Buildings: Biological Agents, Sources, Preventive Measures. Ann. Am. Conf. Govt. Ind. Hyg. 10:21, 1984.

Rylander, R., Morey, P.: Airborne Endotoxin in Industry Processing Vegetable Fibers. Am. Ind. Hyg. Assoc. J. 43:811, 1982.

Rylander, R., Snella, M.C.: Endotoxins and the Lungs: Cellular Reactions and Risks for Diseases. Prog. Allergy 33:332, 1983.

Rylander, R., Persson, K., Goto, H., Yuasa, K., Tanaka, S.: Airborne Beta-1,3-D-Glucan May Be Related to Symptoms in Sick Buildings. Indoor Environ. 1:263, 1992.

World Health Organization.: Indoor Air Pollutants. Copenhagen, 1983.

Zweiman, B., Levinson, A.L.: Cell-mediated Immunity. In: Allergy. Principles and Practice. Vol.1, E. Middleton, C. Reed, E. Ellis, Eds., C.V. Mosby, St. Louis, MO, 1983.

2. AIR TREATMENT SYSTEMS

In modern buildings, heating, ventilation and air-conditioning systems (HVAC) act as air treatment systems and directly affect the quality of the work environment. The components of these systems must not only be maintained at optimum operating conditions, but also under healthy conditions that minimize the risk of the appearance of sources of contamination of the ambient air.

In order to identify the potential sites of growth of microorganisms and to limit their development, it is important to understand the role of each ventilation system component and their psychrometric operating conditions.

2.1 Components

Although several types of distribution systems exist, namely single or dual duct, constant volume (CV) or variable air volume (VAV), and constant temperature or variable temperature, central air treatment units (figure 2.1) generally consist of some or all of the following components:

- outdoor air intake;
- mixing plenum;
- fan(s);
- filtration unit;
- heating, cooling and dehumidification coils;
- humidifier;
- dampers;
- sound attenuators;
- ducts;
- temperature, humidity and flow control devices;
- heat recovery system.

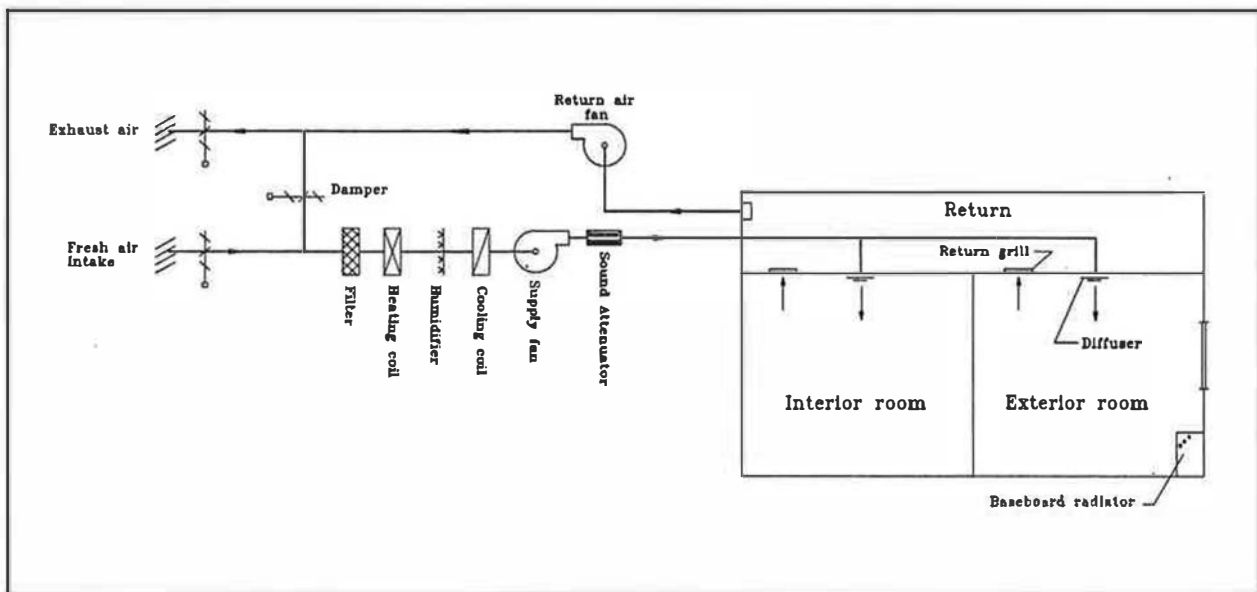

Figure 2.1: Mechanical ventilation system

Air supply and return networks consist of some or all of the following components:

- ducts;
- thermal or acoustic insulation;
- humidifier(s);
- dampers;
- terminal boxes and diffusion units;
- control devices;
- peripheral units.

The presence of water in ventilation systems is a determining factor in the development of microorganisms because it promotes their growth. Under dynamic operating conditions, the components of a ventilation system are exposed to temperature and humidity levels that vary in relation to the configuration of the system and the air conditioning processes.

2.2 Air conditioning processes

Four (4) processes condition the air, namely cooling, heating, humidification and dehumidification. Depending on the design of the HVAC system, conditioning can be achieved either at the central unit or in the distribution network. The different air-conditioning phases result in variations in the properties of the air, namely the temperature, relative humidity, and the enthalpy. The properties are represented graphically in the psychrometric diagram (figure 2.2) which also presents the different conditioning processes for humid air (figure 2.3).

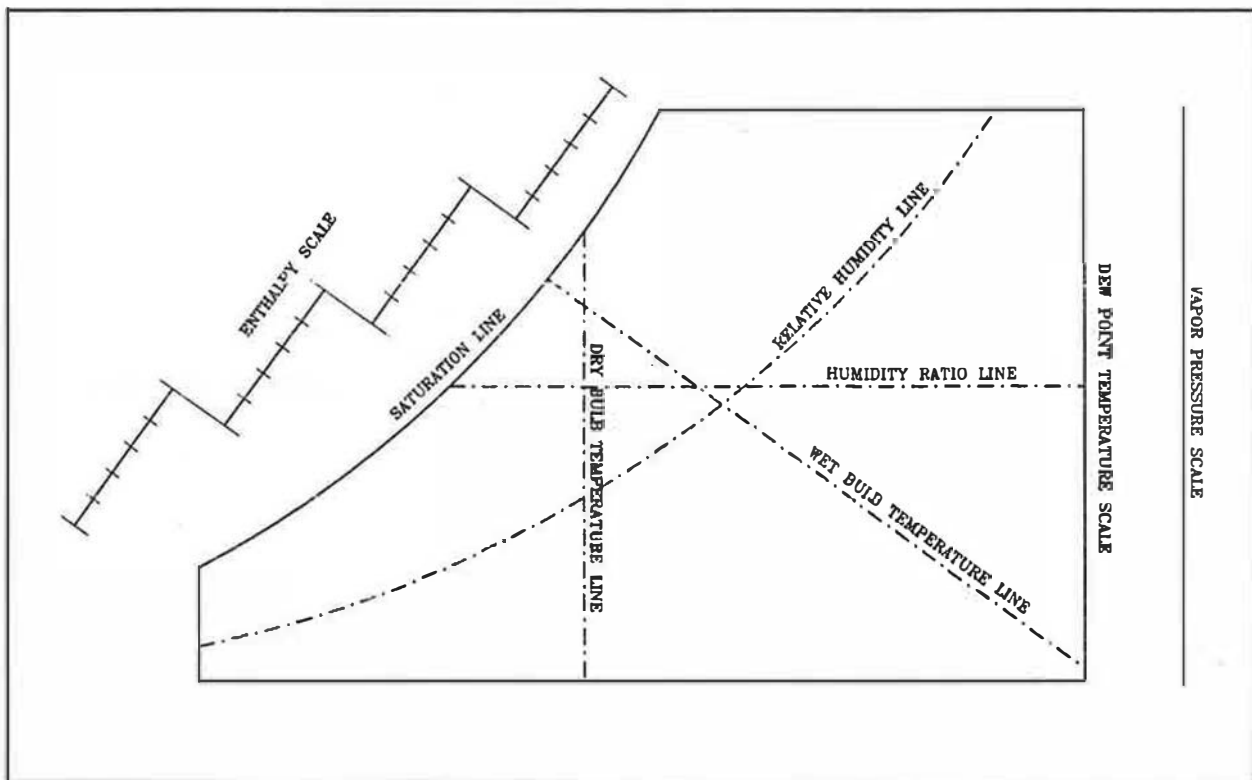

Figure 2.2: Psychrometric diagram

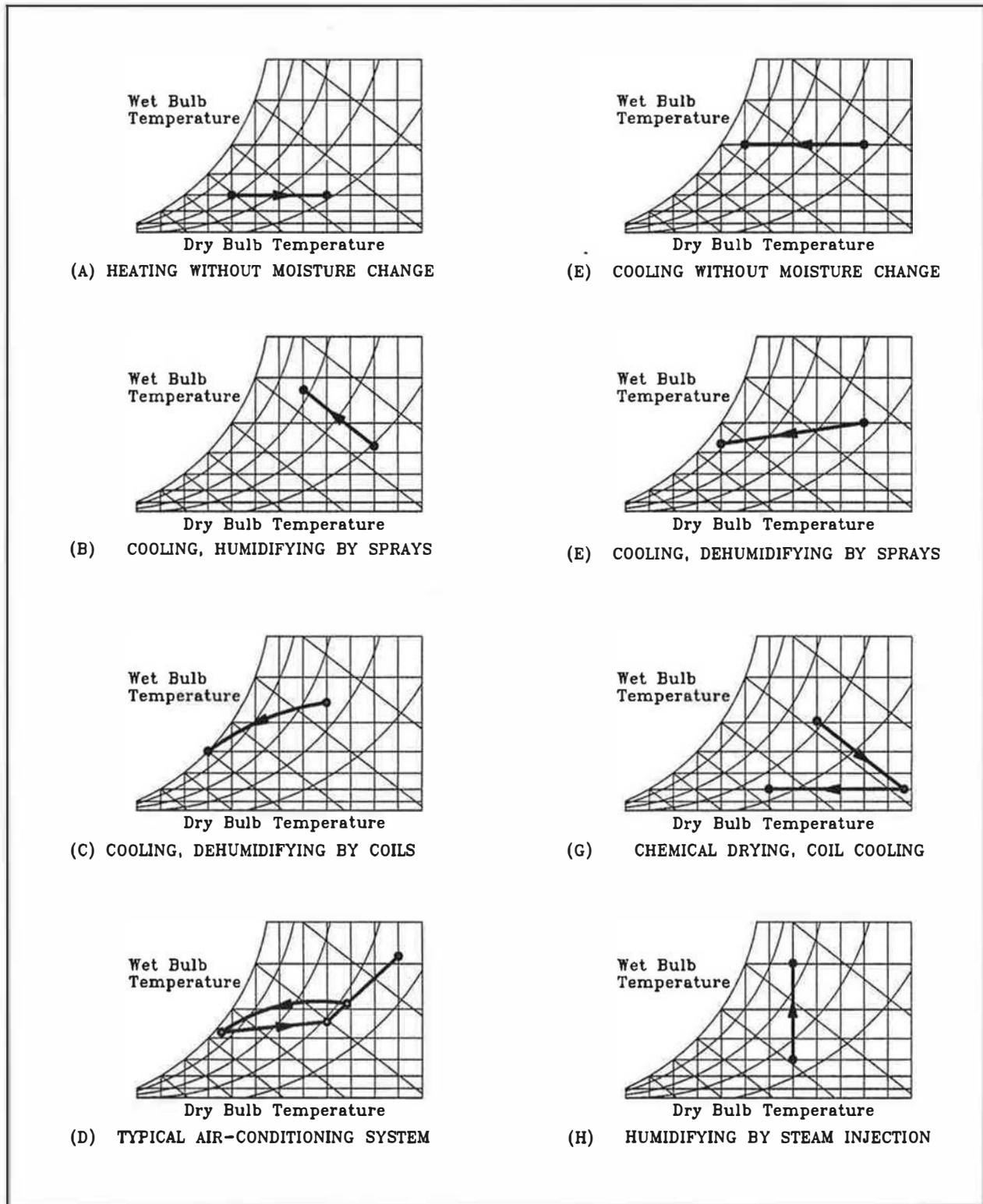

Figure 2.3: Fundamental air-conditioning processes

2.2.1 Cooling and dehumidification

The air is cooled by reducing the sensitive heat (figure 2.3e) that results from the heat exchange between the humid air and the refrigerant (direct-expansion cooling system) or the cold water (chilled-water cooling system) flowing in the cooling coils. When the temperature of the coil is below the dew point (temperature at which water begins to condense in a gaseous mixture that is being cooled) of the treated air, dehumidification of the air and condensation are noted (figure 2.3c). In this case, the cooling coil reduces the sensitive heat and the latent heat of the air.

Although the main method of dehumidifying air is by using cooling coils, it can be achieved chemically by passing the air through a chemical dehumidifier. The water vapor is removed from the air by adsorption or absorption by means of a solid or liquid desiccant with a vapor pressure below that of the treated air. The exothermic reaction initiated by the water-desiccant mixture results in an increase in air temperature (figure 2.3g). Chemical dehumidifiers are also used in certain installations because of their filtration capacity. The chemical dehumidifier can be located upstream from the cooling coil to avoid the formation of condensate at the coil.

In certain systems, dehumidification is carried out in a spray chamber called an air washer, by passing the air through sprayed water whose temperature is maintained at a level below the dew point of the treated air (figure 2.3f).

2.2.2 Heating

The air is heated by passing it through an electric heating coil or fluid-filled coil in which steam or hot water is flowing. The increase in air temperature is accompanied by a decrease in humidity (figure 2.3a).

2.2.3 Humidification

Air is humidified mainly by two (2) methods, either by evaporating liquid water or by injecting saturated steam. In the first case, the water is sprayed or atomized into an air flow which, by transferring some of its energy, evaporates the water. The energy thus removed is absorbed by the vapor in the form of heat of vaporization. In the case of air washer humidifiers, the water is sprayed and continuously recirculated in a chamber, such that the temperature of the water on contact with the air becomes equal to the wet-bulb temperature of the air. To humidify the air with atomized water, the water temperature must be above the final dew point required for the air. Therefore, since the vapor pressure of the water is greater than the partial pressure of the water in the air, it is this difference in pressure that causes evaporation. Since the wet-bulb temperature of the air is constant, the latent heat necessary to evaporate the water comes from the sensitive heat of the air, which leads to a drop in the dry-bulb temperature of the air. The amount of sensitive heat lost by the air is offset by a gain in latent heat, thus keeping the overall heat content (enthalpy) of the air constant (figure 2.3b).

When the air is humidified by injecting saturated steam, an increase in the relative humidity of the air under constant dry-bulb temperature conditions is observed (figure 2.3h).

Bibliography on air treatment systems

AQME.: Guide pratique d'entretien pour une bonne qualité de l'air intérieur. Association québécoise pour la maîtrise de l'énergie, 1989.

ASHRAE.: ASHRAE Handbook. HVAC Systems and Equipment. SI Edition, American Society of Heating, Refrigerating and Air-Conditioning Engineers, Inc., Atlanta, GA, 1992.

ASHRAE.: ASHRAE Handbook. Fundamentals. SI Edition, American Society of Heating, Refrigerating and Air-Conditioning Engineers, Inc., Atlanta, GA, 1992.

ASHRAE.: ASHRAE Handbook. HVAC Applications. SI Edition, American Society of Heating, Refrigerating and Air-Conditioning Engineers, Inc., Atlanta, GA, 1992.

Bureau de l'efficacité énergétique, Government of Québec, L'efficacité énergétique dans les édifices à bureaux et les bâtiments commerciaux. 1991.

Kundsin, R.B.: Architectural Design and Indoor Microbial Pollution. Oxford University Press, New York, 317 p., 1988.

McQuiston, F.C., Parker, J.D.: Heating, Ventilation, and Air Conditioning. John Wiley & Sons, Third Edition, 746 p., 1988.

Pickering, C.A.C., Jones, W.P.: Health and Hygienic Humidification. The Building Services Research and Information Association, Berkshire, 1986.

Wark, K.: Thermodynamics. Third edition, McGraw-Hill, USA, 909 p., 1977.



3. BIOCONTAMINATION OF COMPONENTS

3.1 Outdoor air intakes

In order to comply with standards and regulations, an HVAC system must introduce fresh air whose quantity varies in relation to the activities taking place in the building.

Outdoor air is the first source of any microbial growth. Most fungi (yeasts and molds) and several types of bacteria live in the natural environment. Fungal spores generally dominate the outdoor microflora. For example, millions of mold spores per minute can be released when a farmer works in his fields. It is important to examine the outdoor environment to identify potential sources and to take samples that will be used as a control for future indoor samples.

The architectural layout and the location of air intakes can in some cases be factors contributing to the admission, and later, the development of microorganisms in the ventilation system. Bioaerosols originating from the following sources are likely to be sucked in through the intake and settle on the various components of the ventilation system:

- snow and rain (figure 3.1);
- air exhausted by the sanitary vents which may contain enteric or intestinal bacteria;
- chimneys;
- vitiated air from storage areas (figure 3.2);
- entrained water from cooling towers and evaporative condensers which is particularly likely to be contaminated by *Legionella pneumophila* bacteria;
- plant matter (leaves, birds nests);
- fecal matter (bird droppings which may contain the infectious fungi *Histoplasma* and *Cryptococcus* as well as other fungi and bacteria);
- stagnant puddles of water.

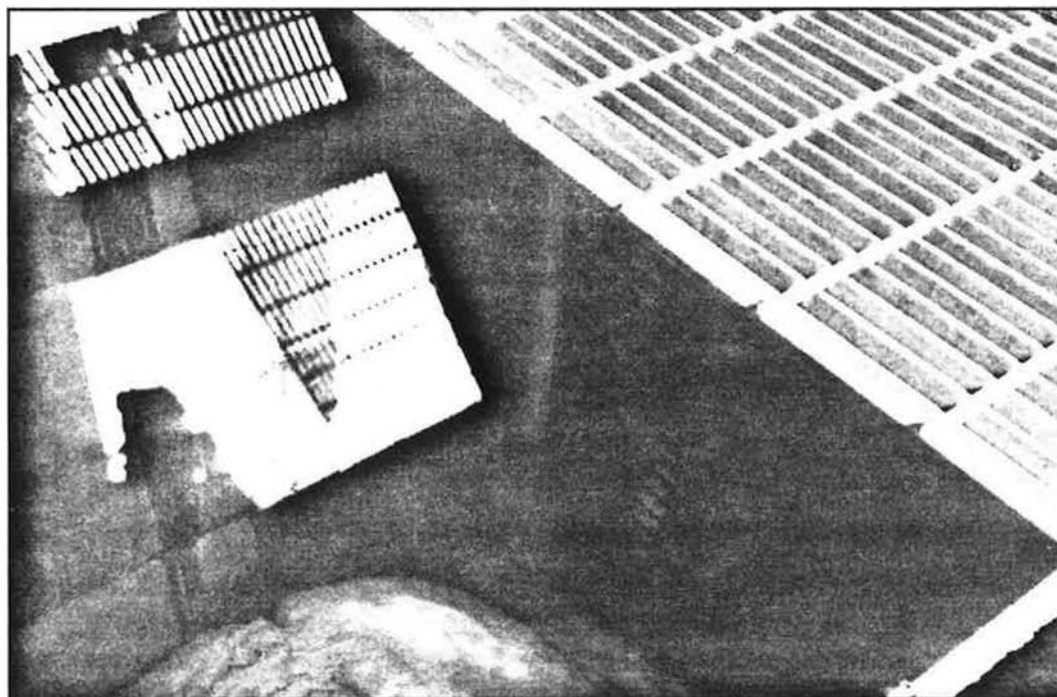

Figure 3.1: Outdoor air intake located below ground level

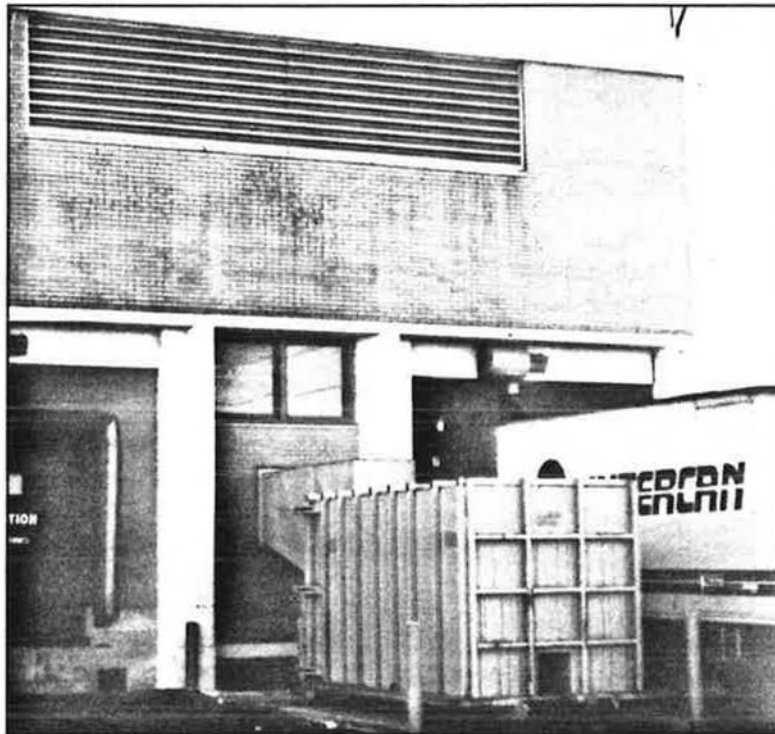

Figure 3.2: *Vitiated air from storage areas*

3.2 Mixing plenum

Fresh air is admitted through the louvers and then mixed with return air (except in systems admitting 100% fresh air) in a box in the central unit. When the plenum consists of perforated sheet metal and insulating wool, accumulated dust (figure 3.3) and water originating from the outdoors or from the condensation that may form on a poorly insulated wall constitute a potential risk for the development of microorganisms.

When there is a problem of stratification between the fresh air and the recirculated air, the temperature of one of the components could be below the dew point of the return air, thus promoting water vapor condensation.

There is also a risk of condensation when the system is turned off and the temperature of the walls reaches the dew point of the air in the ducts.

3.3 Filtration unit

Most often, the filtration unit is located downstream from the mixing plenum and has the role of cleaning the air of airborne particles, and preventing dirt build-up. As a result, the resistance of the system does not increase and the components provide the output for which they were chosen.

For most manufacturers, the filtration efficiency is determined using ASHRAE (American Society of Heating, Refrigerating and Air-Conditioning Engineers Inc.) 52.1-1992 which specifies two (2) test methods, namely the arrestance method and the dust spot efficiency test.

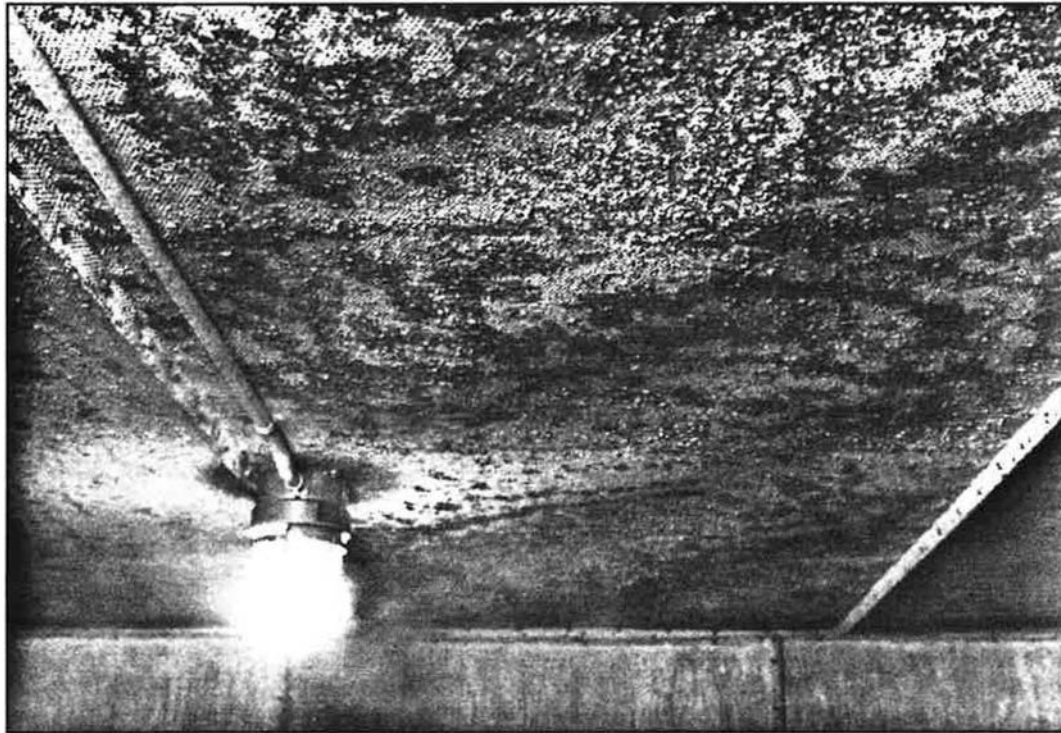

Figure 3.3: *Build-up of debris and rust on the walls of a mixing plenum*

A filter that cannot retain particles whose diameter is smaller than that of the microorganisms likely to be found in the environment is the first way for bioaerosols to enter the HVAC system. Although the efficiency of media style filters increases with clogging, they must be replaced when the increased resistance to air flow reaches a level that prevents the ventilation system from supplying the air flow desired. A differential manometer is used to measure the pressure drop caused by clogging, and the lifetime of the filters can then be determined. Microbial growth in the filtration unit occurs mainly when filters are not replaced according to the manufacturer's specifications. Although biological contaminant development mechanisms are complex, contamination of this component is often associated with the presence of water in the system and an excessive accumulation of dusts, particularly

organic ones. In fact, water in the filters means that fungal spores may germinate, grow, and produce spores. These spores may then be released into the indoor air (figure 3.4).

Microbial growth may also occur in the components downstream from the filtration unit when the filter holding-frame hardware is not airtight with the frame. Since it has a lower flow resistance, this space is a preferred path for unfiltered air, and the filtration efficiency drops. Following periodic checks of a filtration unit, the pressure drop could stabilize at a level that is not near the value recommended for replacement. This situation could be due to tearing of the filter or the presence of leaks in its frame or in the walls of the plenum located between the filtration section and the fan.

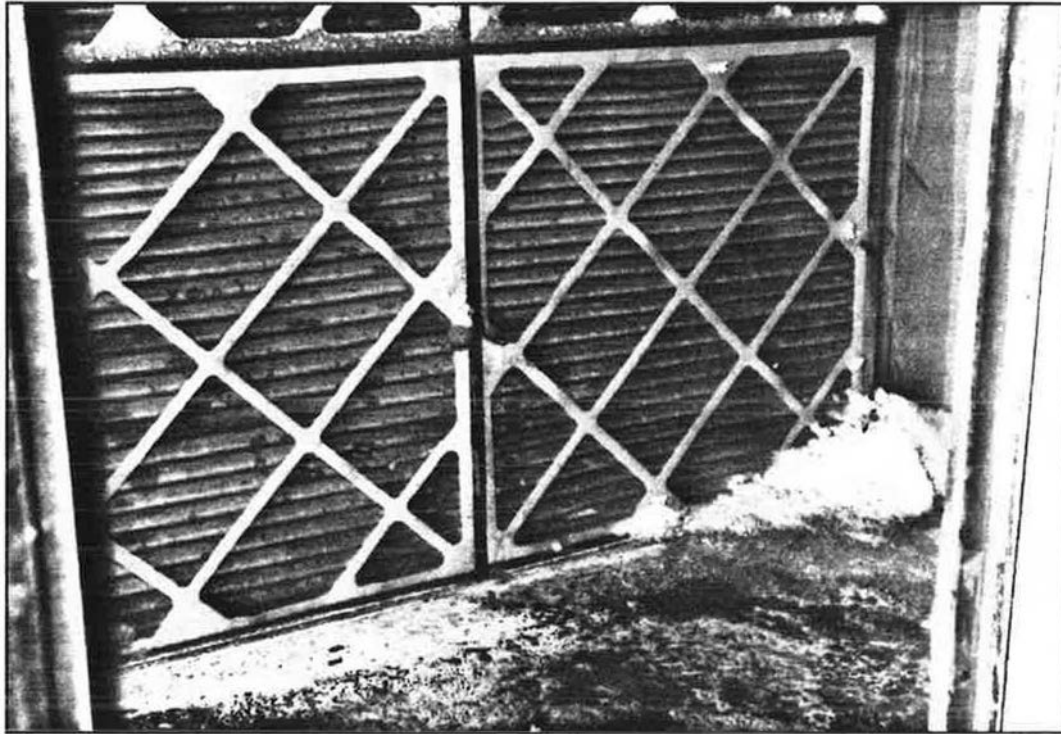

Figure 3.4: *Filters damaged by outdoor environmental conditions*

3.4 Heating and cooling coils

The filtered air is then directed to the coils for heating or cooling. During the air-conditioning mode with dehumidification, condensation water is recovered in a drain pan located under the coil and is evacuated by a drain (figure 3.5). Microbial growth in this equipment originates mainly from the following sources: water accumulating at the base of the coil due to an incorrect slope of the coil, and the inability of the drain to drain the water from the pan due to blockage or to the pan sloping in the wrong direction.

Some pans are insulated inside, thus preventing them from completely drying out and also allowing debris to collect. Foam or viscous and sticky deposits in the drain pans indicate the presence of microbial growth. When microbial growth is not visible, water samples can show in analysis the presence of fungi and bacteria.

When the face velocity of the air is too high, there is a risk that the water will be entrained by the air even before it can reach the drain pan. If there is acoustic insulation nearby and it becomes wet, it is a suitable breeding ground for microorganisms, particularly if there is dust build-up on the walls.

Contamination is generally not a problem at the heating coil during operation. This is due to the high temperatures which do not promote the development of living organisms, unless there is a water or steam leak and water can collect on a porous surface or at the bottom of the unit. However, when the system is stopped for a prolonged period, particle build-up on this component may result in microbial growth.

3.5 Humidifiers

Air humidification for specific purposes or for comfort requires particular attention because of the high risk of contamination. According to ASHRAE, there is a risk of microbial growth when the relative humidity in occupied areas or in low-velocity ventilation ducts (<10 m/sec) exceeds 70%. The humidifier must be located where the air can absorb the water vapor that will not be cooled below its dew point. To ensure that the water vapor reaches gaseous equilibrium, the location of the distributor must take into account the distance from the duct walls as well as air temperature and velocity.

In general, humidification systems are controlled by a humidistat located in the room or in the return duct. In some HVAC systems operating at low temperature, a high-limit humidistat is installed downstream from the humidifier to prevent the vapor from condensing. An airflow sensor installed in the duct starts the system.

3.5.1 Heated pan humidifiers

In this type of humidifier (figures 3.6 and 3.7) placed under the ventilation duct, water vapor is produced by a heat exchanger (steam or hot water) or by heating elements immersed in the pan. This water is carried or driven by a fan located in the air flow.

The entrainment of the water droplets formed by an excessive air velocity in the duct or by an excessive temperature in the heat exchanger (vapor above 103 kPa) could result in the wetting of the acoustic insulation located nearby.

When ventilation systems are not operating, the stagnant water in the pan is a breeding ground for microorganisms that can be aerosolized when the systems are turned on.

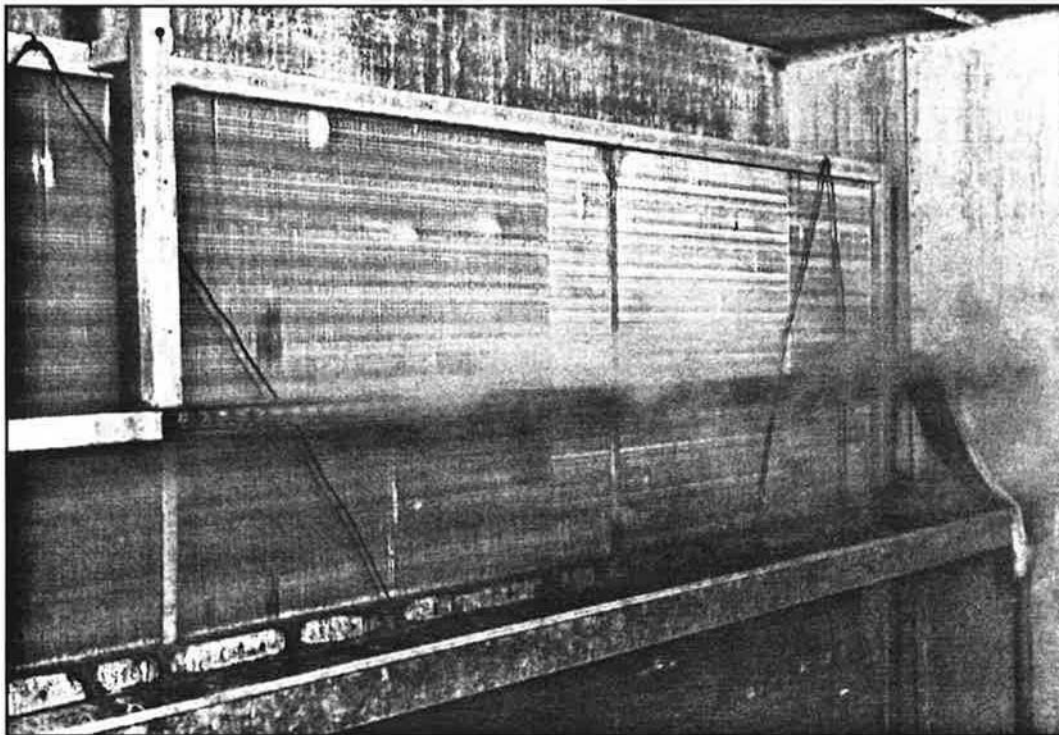

Figure 3.5: Cooling coil drain pan

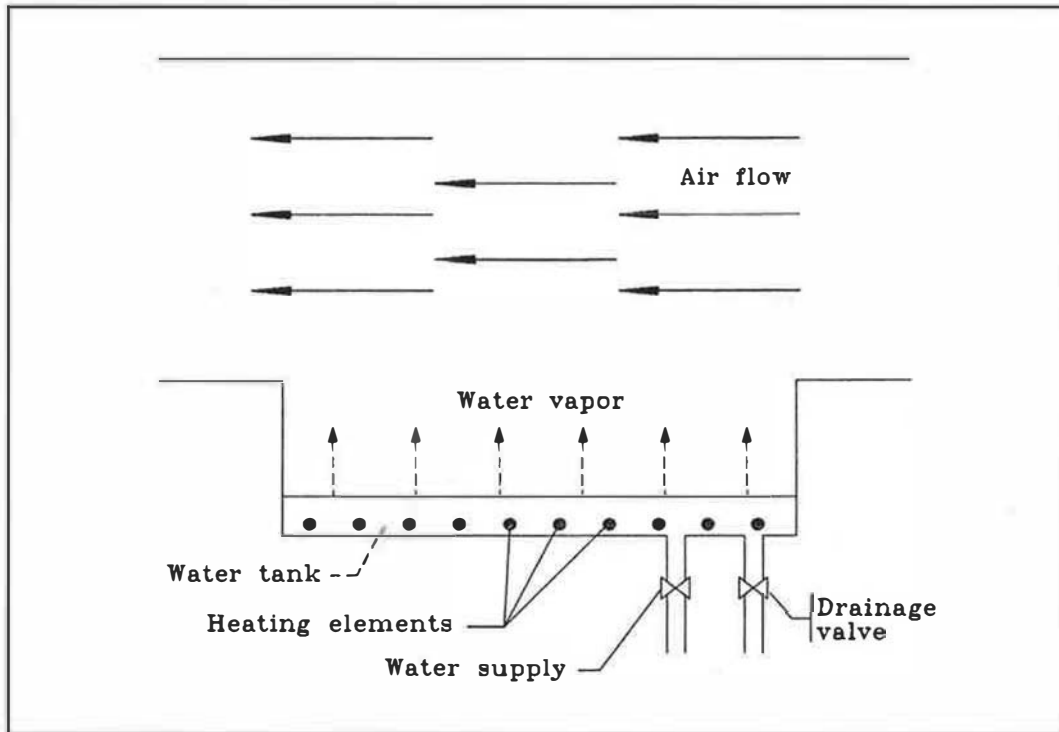

Figure 3.6: Diagram of a heated pan humidifier

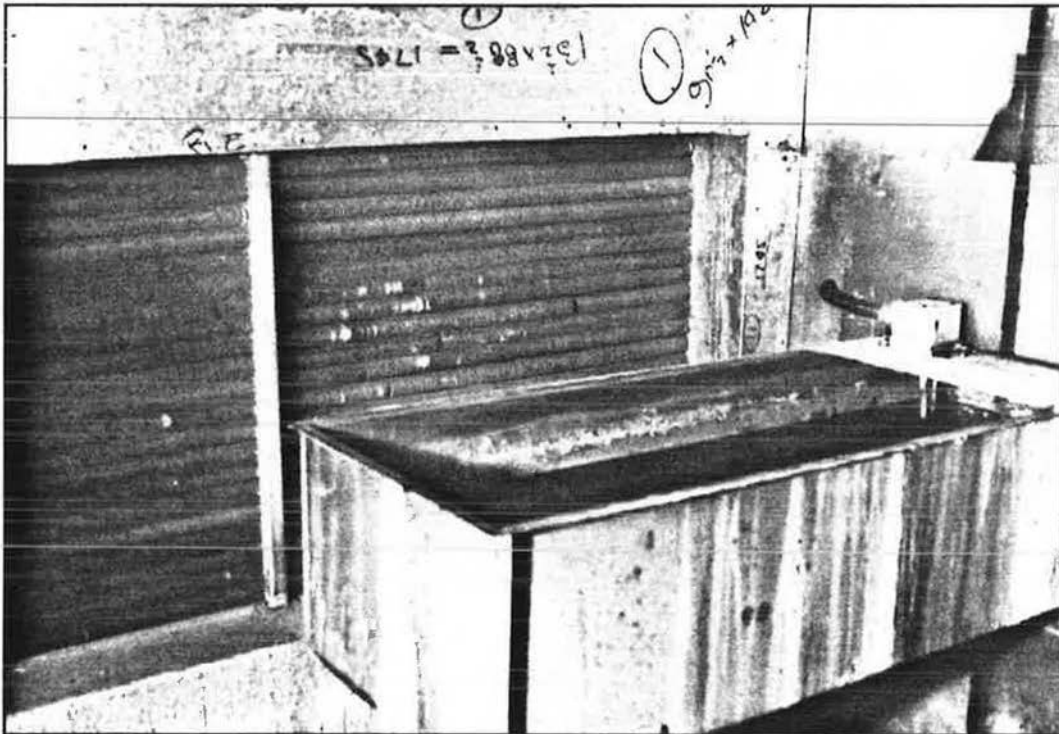

Figure 3.7: Heated pan humidifier

3.5.2 Saturated steam humidifiers

Saturated steam humidification systems are used extensively due to their flexibility and their high vapor-production capacity. Steam is generated in a central boiler, or locally by electrolysis, and is injected at the central ventilation unit or directly into the duct.

In the first case, the steam can be introduced through one or more dispersing tubes called vapor jacketed tubes. The jacketed tube consists of a double-walled tube whose outside envelope (figure 3.8) allows the steam discharge tube to be maintained at a temperature above the dew point, to avoid the formation of condensation which could be entrained in the air flow. Before

entering the discharge tube, the steam flows into a separator equipped with a trap that removes the condensate that may have formed in the distribution system. This steam is called dry steam.

The amount of injected steam is controlled by a pneumatic or electric valve of the on-off or modulation type. To avoid water passing into the discharge tube, the temperature measured upstream from the trap must be high enough, which triggers the supply valve. A malfunction in the valve may also result in excess steam being released into the system. A release of water by the discharge tube is generally caused by a problem in the condensate-drainage or steam-supply networks.

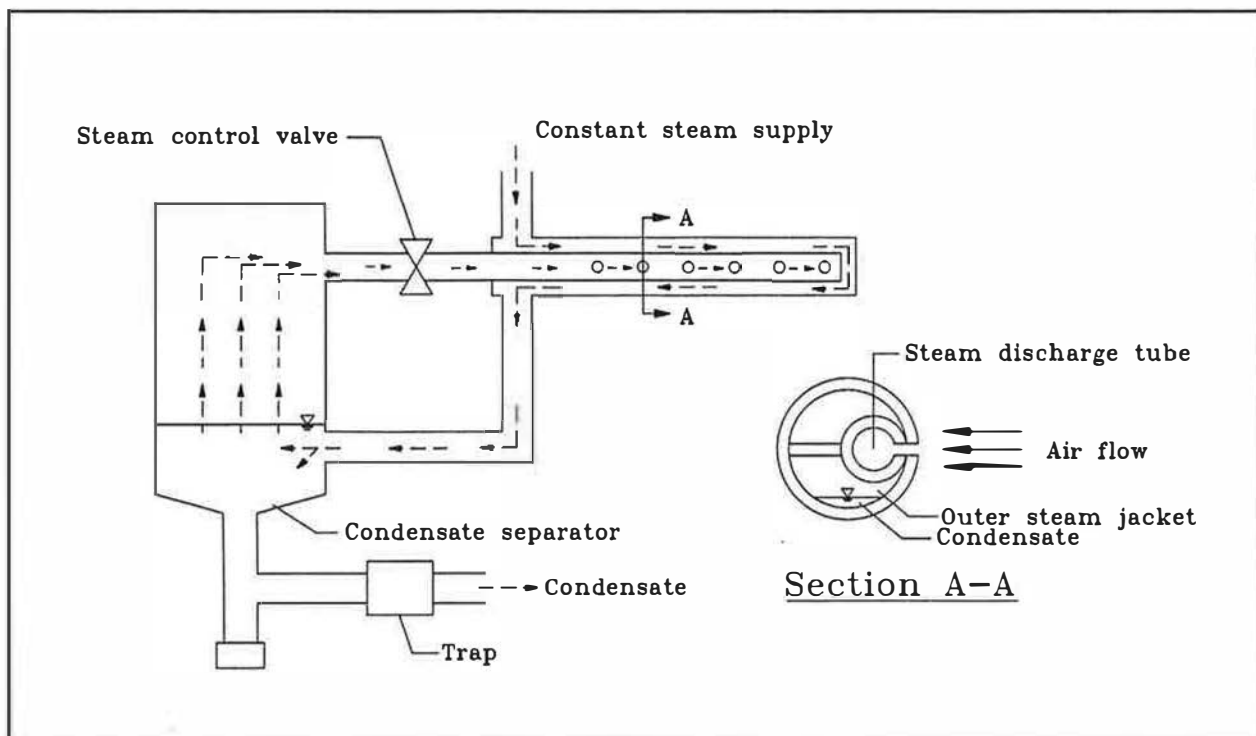

Figure 3.8: Diagram of a dry steam humidifier

In the case where a local generation unit (figures 3.9 and 3.10) is used, the distributor is single walled and is exposed to the air flow. To eliminate the condensate that may form inside, the distributor is equipped with drainage valves or is installed on a slope (depending on the model). If the distributor supply pipe sags, water could accumulate and be injected into the duct. When the humidifier is not operating for an extended period, microbial growth may occur inside the tank.

3.5.3 Atomizing humidifiers

The operating principle of atomizing humidifiers (figure 3.11) consists of producing fine droplets of water for easier evaporation. These droplets

are generated by different equipment: centrifuge atomizer, ultrasonic vibrating plates, and sprayers with or without ultrasonic nozzles.

At the present time, these types of equipment are not extensively used in a central system and the main risk identified involves water entrainment. The presence of a water eliminator and a drain pan depends on the type of equipment installed. If water and debris accumulate in the tank, microbial growth is possible. In some of these systems, the water is filtered and stored in a tank before supplying the humidifier. If this water remains stagnant for too long, microorganisms may multiply.

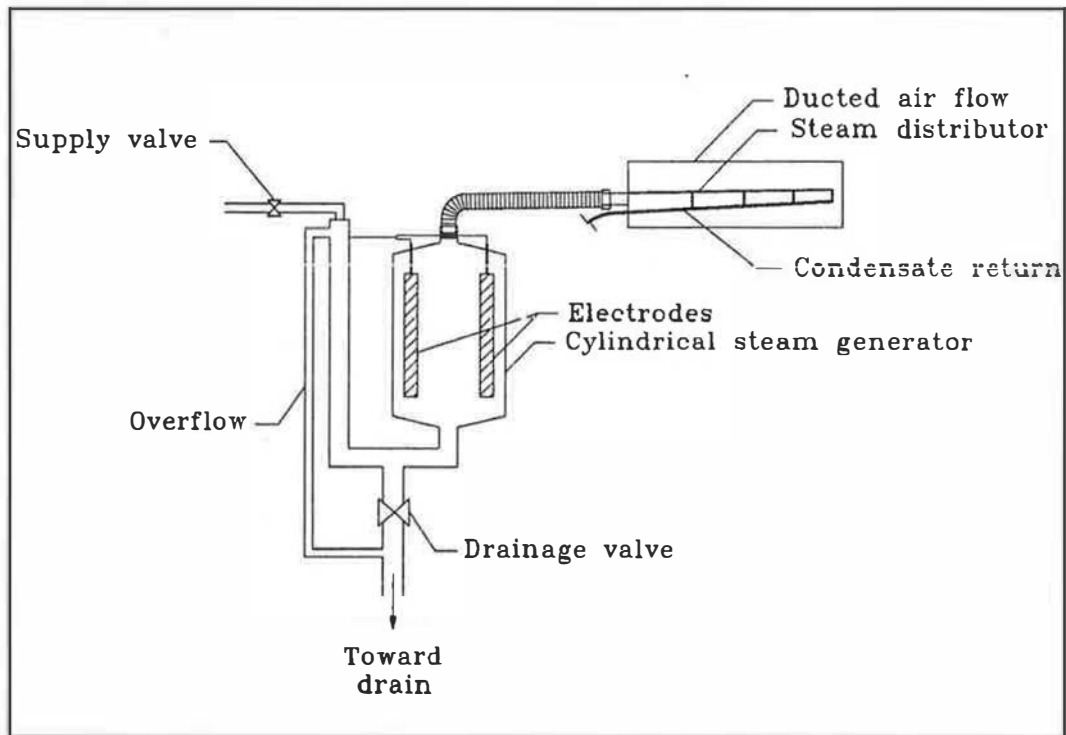

Figure 3.9: Diagram of a self-contained steam humidifier

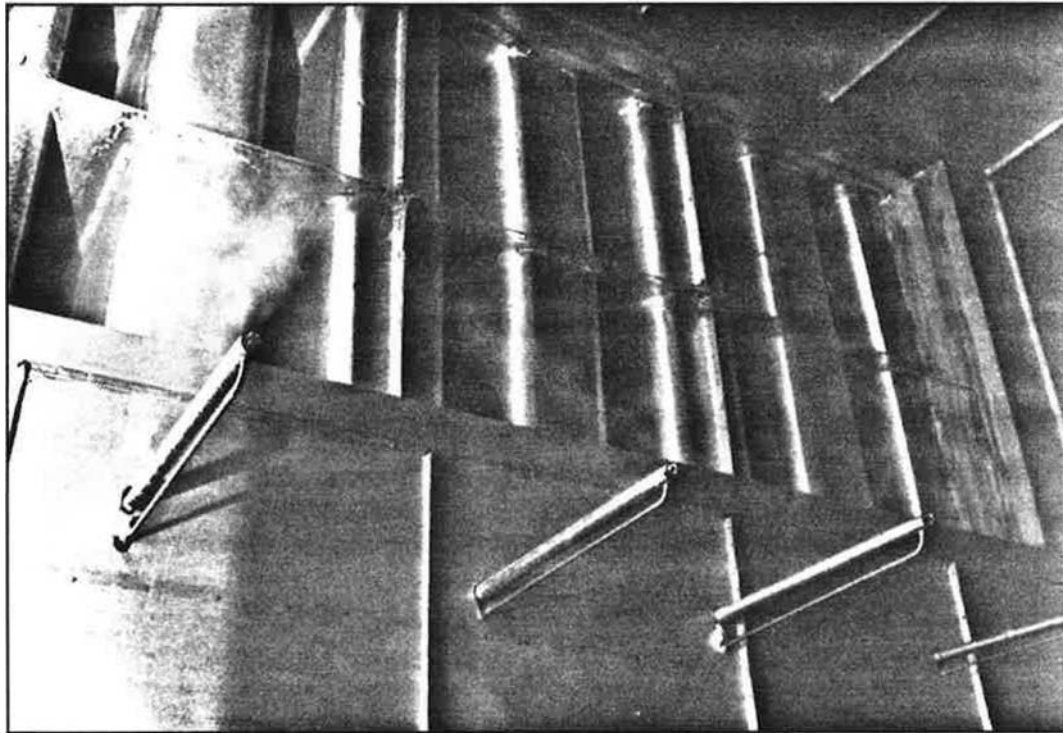

Figure 3.10: Self-contained steam humidifiers

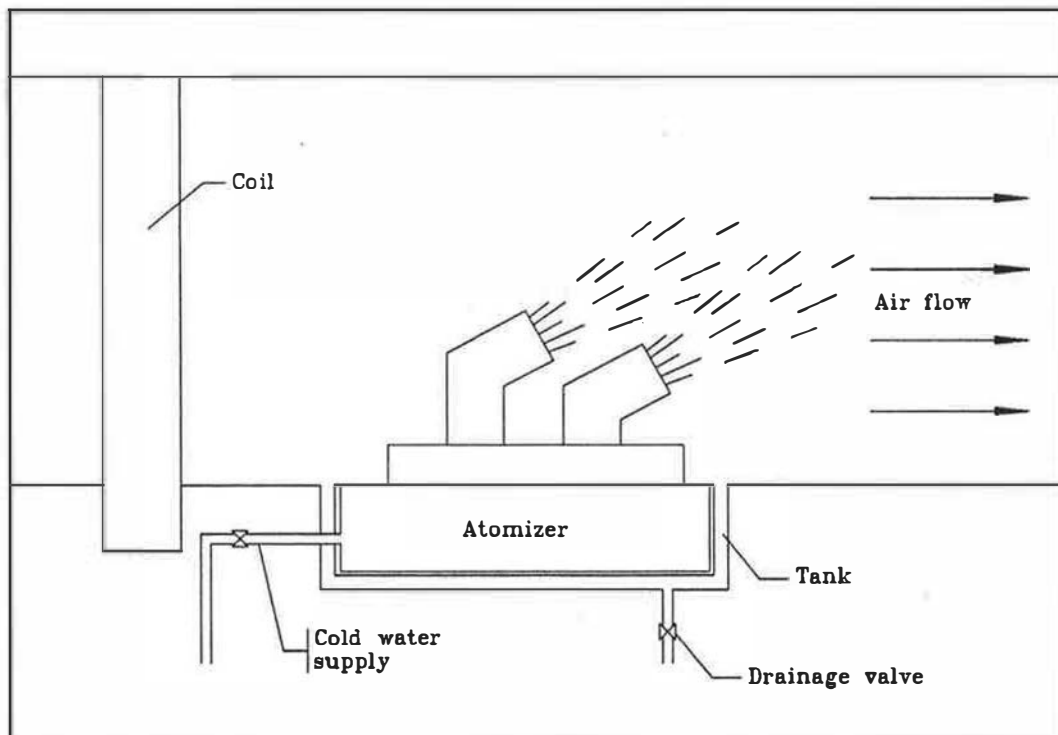

Figure 3.11: Diagram of an atomizing humidifier

3.5.4 Spray humidifiers

Although the use of spray humidifiers (figures 3.12 and 3.13) is decreasing, a large number remain in service and require particular attention due to the high risk of microbial growth.

At the outlet of the spray chamber, a plate eliminator is installed which stops the droplets as well as the organic dusts and debris carried by the air flow. Under the action of the sprayers or in hitting the moist surfaces of the plates, the particles and droplets are deposited in the pan and on the wet surfaces of the chamber. When spray humidifiers are insufficiently maintained (figure 3.14), microorganisms often grow on the wet mechanical surfaces, in the tank and on the porous surfaces. With exceptions, this type of

humidifier is designed for installation on the suction side of the fan, which avoids problems with water leaks. The complete humidifier section is generally based on an air velocity varying from 1.5 m/sec to 3 m/sec. If the velocity is higher, water entrainment problems may occur.

During operation, the water is continuously recirculated and the use of biocides to control contamination does not completely eliminate the microorganisms. Furthermore, the emission of these chemicals into the air may lead to other problems, particularly if the dose is poorly adjusted or during the start-up of the system after a period of inactivity. Some products are used in these humidifiers even though they are intended for other uses.

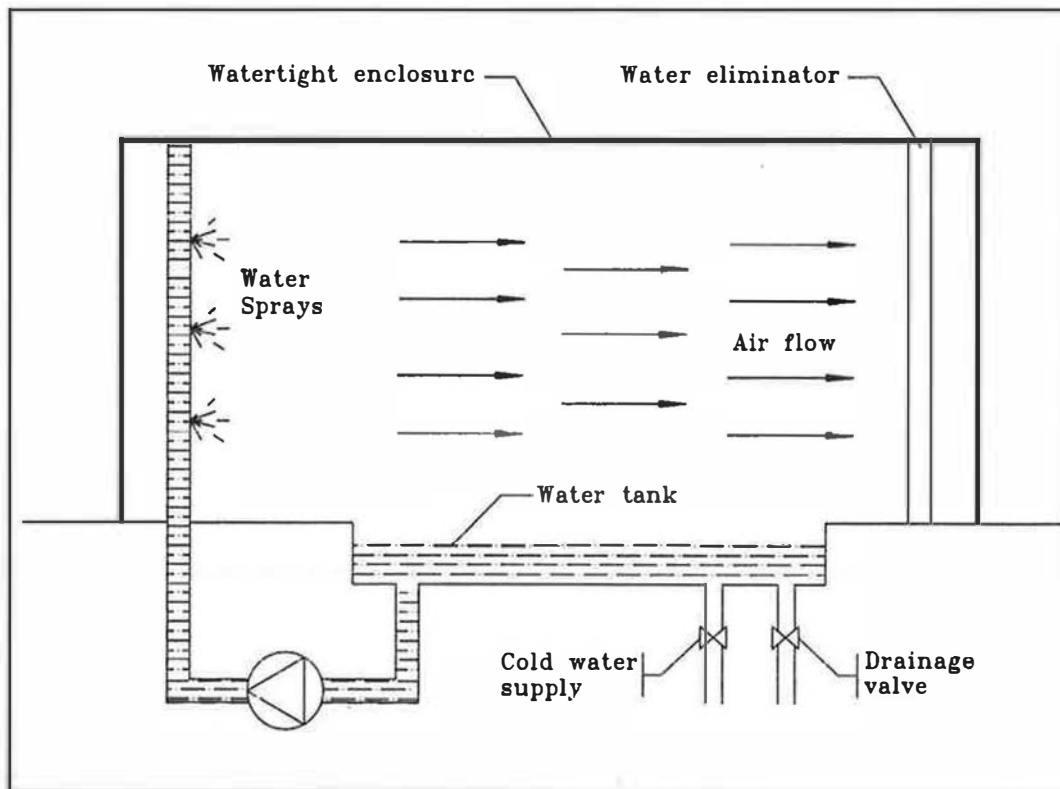

Figure 3.12: Diagram of a spray humidifier

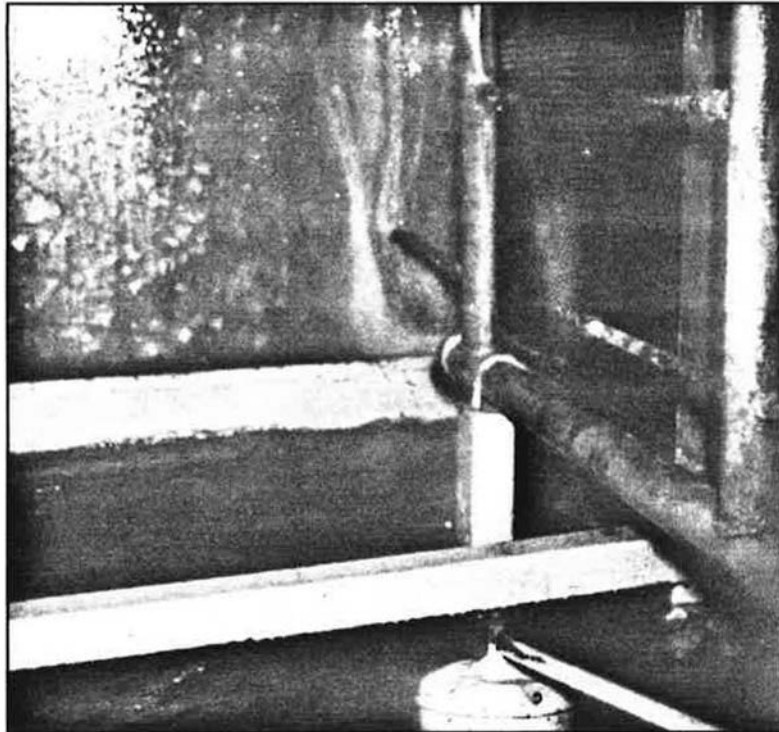

Figure 3.13: *Spray humidifier*

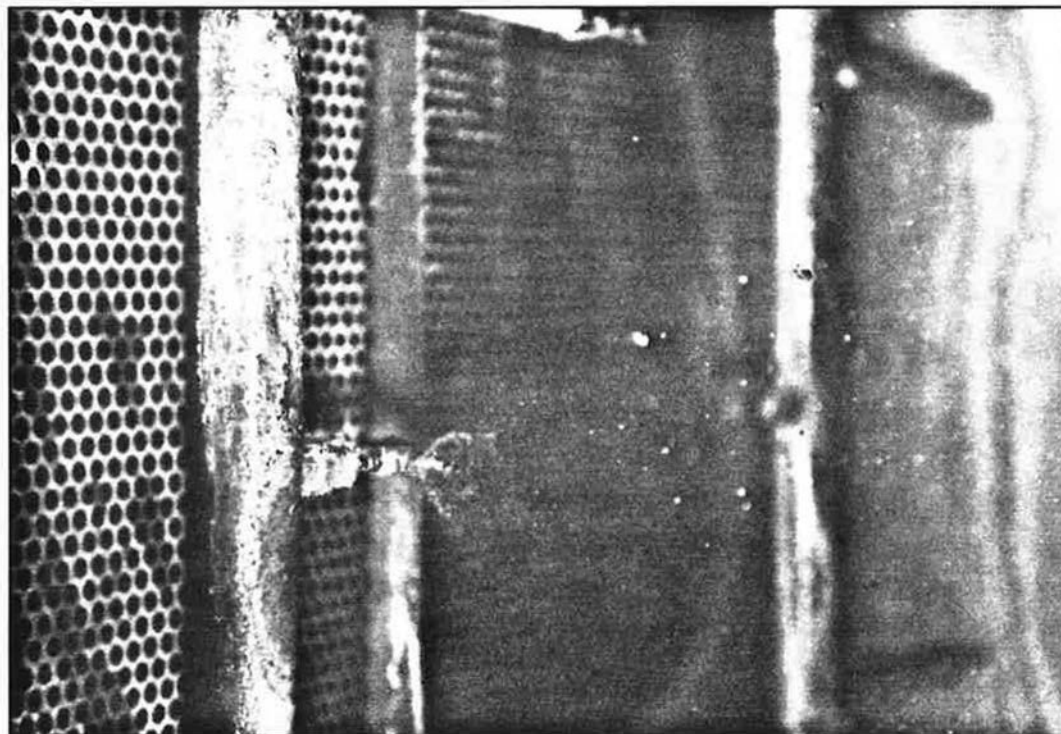

Figure 3.14: *Build-up of dirt inside the humidifier*

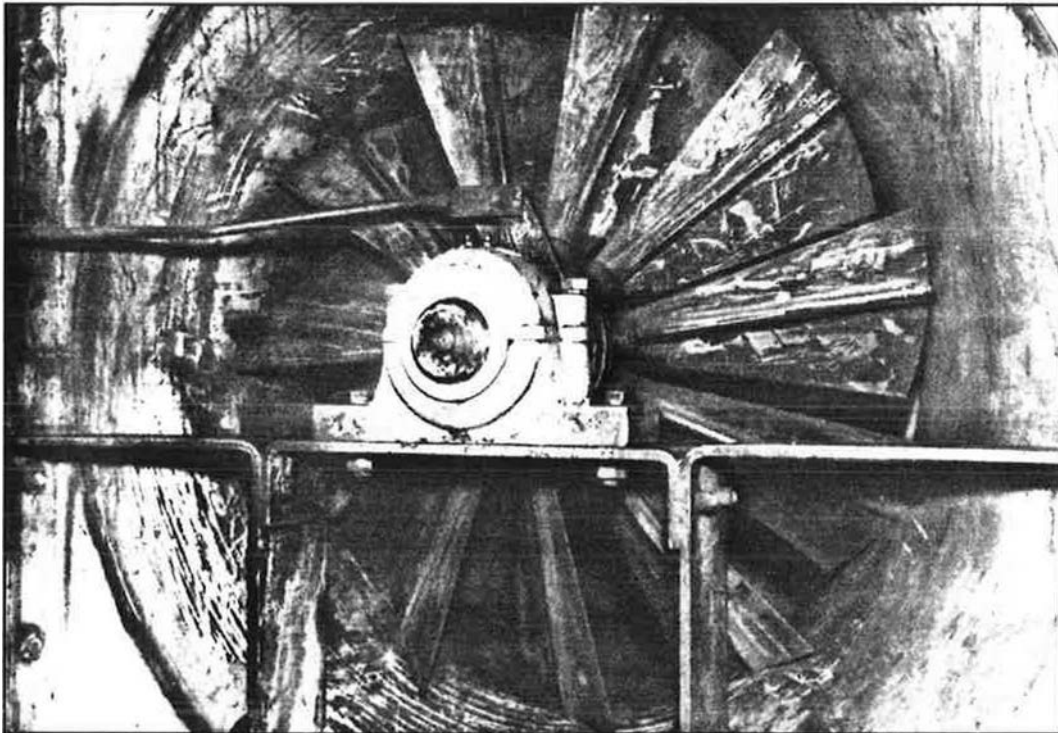

Figure 3.15: *Build-up of dirt at the fan*

3.6 Fans

These structures may also serve as microbial contaminant reservoirs due to dirt build-up (figure 3.15).

3.7 Air supply and return ducts

Air is distributed into the rooms through metal or fiberglass ducts which can be covered with outer insulation to limit heat losses and to prevent condensation, or inside for thermal and acoustic insulation as well as to prevent condensation. The insulation generally consists of fibrous materials and is rigid or else flexible and porous. Depending on the application, a vapor barrier or air barrier may be installed.

The ducts are never sterile but must not contain deposits of dirt or debris. Metal ducts must retain their metallic appearance. According to Morey et al. (1991), insulating materials showed no presence of microorganisms when tested for the growth of molds in compliance with standardized ASTM (American Society for Testing and Materials) methods C1081 and C665. According to these tests, molds did not proliferate on new fiberglass insulation inoculated with a suspension of molds and incubated at a temperature of 30°C with a relative humidity of 95% for 28 days. However, these tests are valid only for new insulation and must not be used to determine whether the insulation installed in the ducts can support the growth of molds. A thin layer of dust inside insulated ducts is normal.

However, an excessive accumulation of organic dust may increase the moisture absorption capacity of the insulating wool to a level that allows microorganisms to grow (figure 3.16). In rectangular ducts, dust is likely to accumulate, particularly in the spaces in transverse joints.

When the space between a suspended ceiling and the structural slab is used for the air return (return plenum), the temperature of the surfaces and mechanical components (ex.: uninsulated roof drain) may be low enough for the water vapor in the air to condense. Water infiltration through the roof may also moisten the thermal and acoustic insulation and fire protection materials, which then become microorganism amplification reservoirs.

As with the plenums, cooling of poorly insulated ducts when the systems are turned off may condense the moisture contained in the air.

3.8 Sound attenuators

The sound attenuators used in HVAC systems are generally of the dissipative type, with the noise being absorbed by an insulating glass wool material that is protected from the air flow by a perforated metal plate. The insulation may also be covered with a polymer-based film, placed between the insulation and the perforated plate, which protects it from chemicals or premature build-up of dirt.

Sound attenuators could become wet if water is carried from one of the components located upstream. As mentioned previously for ventilation duct insulation, an accumulation of organic dust may constitute a breeding ground for microorganisms. Microbial activity may also be amplified if the insulation is protected by a polymer-based film, the latter being a source of nutrients for molds.

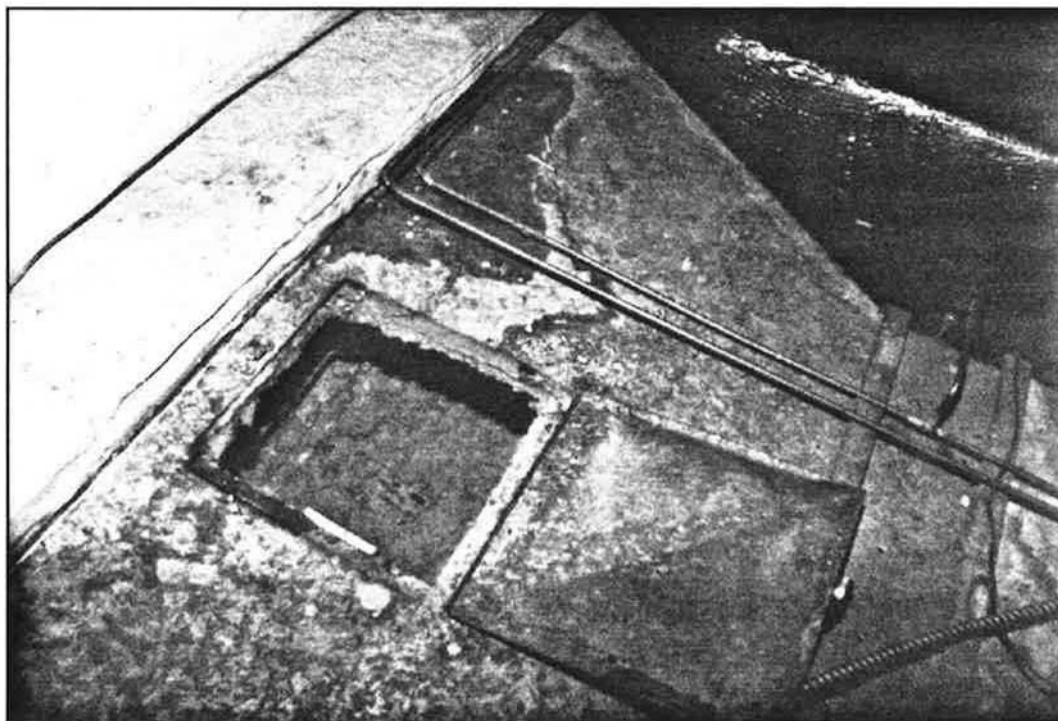

Figure 3.16: *Contaminated acoustic insulation*

3.9 Diffusers and peripheral units

The supply air is injected either directly by a diffuser connected to the duct or is treated in terminal boxes or in a peripheral unit (fan-coil unit, induction unit) before being directed into the room.

At terminal reheat boxes, the presence of leaks in the heat exchanger piping must be verified.

The components of the peripheral units differ depending on their applications. The risks of contamination previously described for cooling coils and insulation materials apply and can be even greater, inasmuch as the maintenance of this equipment is often neglected. Also, units such as fan-coil units or heat pumps installed in the space between the ceiling and the floor above may disseminate bioaerosols into the return air. Some of these units are supplied with chilled water whose temperature is around 7°C. When the pipes are not insulated, condensation could occur. The condensation water from the cooling coils must be eliminated.

3.10 Internal sources

Occupied rooms and particularly their architectural and mechanical components may become major sources of microbial growth. Under favorable conditions, molds are the microorganisms most likely to develop. Molds can grow on surfaces such as walls, in the presence of the following: temperature between 4°C and 40°C, mold spores, basic nutrients, porous surfaces, and humidity. Spores are always present in indoor and outdoor air and are fed by nutrients composed of the dirt particles that are found on the surfaces. A carpet may contain up to 10 million microorganisms (bacteria, actinomycetes, fungi, protozoa, etc.) per square foot. Since the complete elimination of nutrients is practically impossible, controlling the humidity is essential.

Concretely, the following indoor conditions are likely to promote the development and growth of molds or other microorganisms:

- water accumulation on ceiling tiles, carpets and other porous finishes;
- a relative humidity above 70 %, allowing carbon-containing and cellulose materials to absorb enough water to support microbial growth and give off moldy odors (ref. figure 3.17);
- carpets installed in basements on cement floors;
- dust accumulation in carpets, on curtains and wallpaper; if these materials have been damaged by water, they may support microbial growth even if they are now dry;
- water infiltration into outside walls and condensation on the hidden face of walls;
- dust build-up on the diffusers, which may serve as a substrate for microbial growth;
- condensation on walls and windows resulting from too high a relative humidity;
- condensation on walls, due to poor air circulation in a room or the presence of cold surfaces resulting from a thermal bridge in the building envelope;
- poorly maintained portable evaporative or ultrasonic humidifiers;
- transmission of common viruses and bacteria such as *Staphylococcus* and *Streptococcus* by people;
- water accumulation in refrigerator drain pans, allowing the growth of thermoactinomycetes.

Not only do these microorganisms proliferate in the room, but they can be carried into the ventilation system and contaminate its various components.

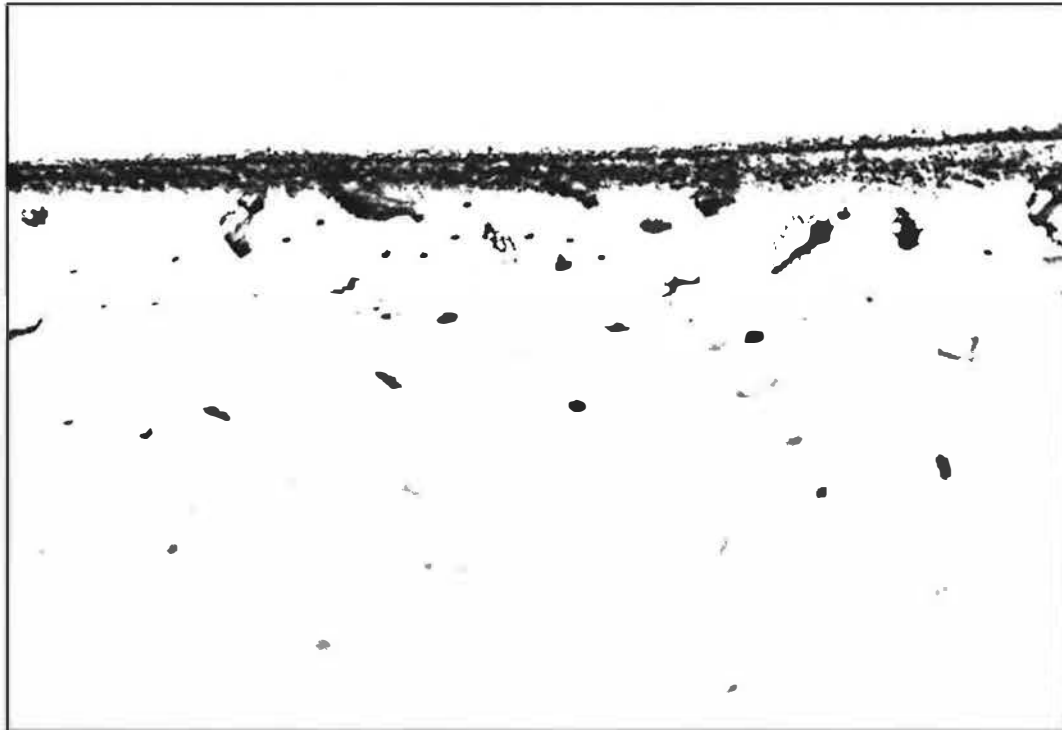

Figure 3.17: *Obvious mold on a ceiling tile*

Bibliography on biocontamination of components

ACGIH: Guidelines for the Assessment of Bioaerosols in the Indoor Environment. Cincinnati, Ohio, 1989.

Ager, B.P., Tickner, J.A.: The Control of Microbiological Hazards Associated with Air-Conditioning and Ventilation Systems. Ann. Occup. Hyg. 27(4):341, 1983.

AQME: Guide pratique d'entretien pour une bonne qualité de l'air intérieur. Association québécoise pour la maîtrise de l'énergie, 1989.

Armstrong Inc.: The Armstrong Humidification Handbook, Bulletin HB-501, U.S.A., 1993.

ASHRAE: ASHRAE Handbook. HVAC Systems and Equipment. SI Edition, American Society of Heating, Refrigerating and Air-Conditioning Engineers, Inc., Atlanta, GA, 1992.

ASHRAE: ASHRAE Standard 62-1989. Ventilation for Acceptable Indoor Air Quality. American Society of Heating, Refrigerating and Air-Conditioning Engineers, Atlanta, GA, 1989.

ASHRAE: Technical Data Bulletin Control of Humidity in Buildings. American Society of Heating Refrigerating and Air-Conditioning Engineers, Inc., Atlanta, GA, 1992.

Dauphin R.: L'humidification et les problèmes de qualité de l'eau qui y sont associés. La maîtrise de l'énergie 6(3):10, 1991.

EPA-NIOSH.: Building Air Quality. A Guide for Building Owners and Facility Managers. Environmental Protection Agency and National Institute for Occupational Safety and Health, DHHS (NIOSH) Publication #91-114, Washington, DC, 1991.

Kundsinn, R.B.: Architectural Design and Indoor Microbial Pollution. Oxford University Press, New York, 317 p., 1988.

McQuiston, F.C., Parker, J.D.: Heating, Ventilation, and Air Conditioning. John Wiley & Sons, Third Edition, 746 p., 1988.

Melson, G.: When Drain Pans Don't Drain. Environment 2(4):2, 1993.

Morey, P.: Controlling Microbial Contamination to Prevent Building-Related Illness and Remediation Costs. Clayton Environmental Consultants, Newsletter, 15(2):1, 1993.

Morey, P.R., Hodgson, M.J., Sorenson, W.G., Kullman, G.J., Rhodes, W.W., Visvesvara, G.S.: Environmental Studies in Moldy Office Buildings. NIOSH Report SF-86-09, No. 3, pp. 399-408, 1986.

NAIMA: Cleaning Fibrous Glass Insulated Air Duct Systems. Recommended Practice. North American Insulation Manufacturers Association, Alexandria, VA, 40 p., 1993.

Nortec: Bulletins techniques. U.S.A., 1990

Ottney, T.C.: Particle Management for HVAC Systems. ASHRAE Journal, July 1993.

Pickering, C.A.C., Jones, W.P.: Health and Hygienic Humidification. The Building Services Research and Information Association, Berkshire, 1986.

Stewart, L.J.: Micro-organisms in Building Services. The Building Services Research and Information Association, Berkshire, 1988.

Trane: Manuel de Climatisation. The Trane Company, La Crosse, Wisconsin, 450 p., 8e édition, 1992.

4. VISUAL INSPECTION AND SAMPLING

Determining the components with potential problems is done by a periodic inspection, whose frequency is based on the system's operating conditions and the potential of recurrence of microbial growth. This process is completed, depending on the observations, by the collection of samples that will later be analyzed in the laboratory.

The application of preventive measures will eliminate or limit conditions favorable for bioaerosol development and proliferation. The implementation or adaptation of a preventive maintenance program will ensure, with its cleaning and adjustment activities, that hygienic components are maintained and that they are in optimum operating condition.

4.1 Visual inspection

A visual inspection of a building and its HVAC system may detect the presence of microorganism growth reservoirs. This visual inspection also checks the effectiveness of ventilation system cleaning. The inspection checklist in table 4.1 presents the various locations in a building that can become sites suitable for the growth of microorganisms that disseminate the bioaerosols described in Chapter 3. This inspection checklist can then be adapted to the different systems and the needs of the users.

When access to the ducts is difficult because there are no openings, for example, a rigid endoscope (borescope) is very helpful (figure 4.1). This device, which resembles a periscope, with a halogen light source, allows the inside of the ducts to be inspected by making a hole some ten millimetres in size. The hole is then sealed by

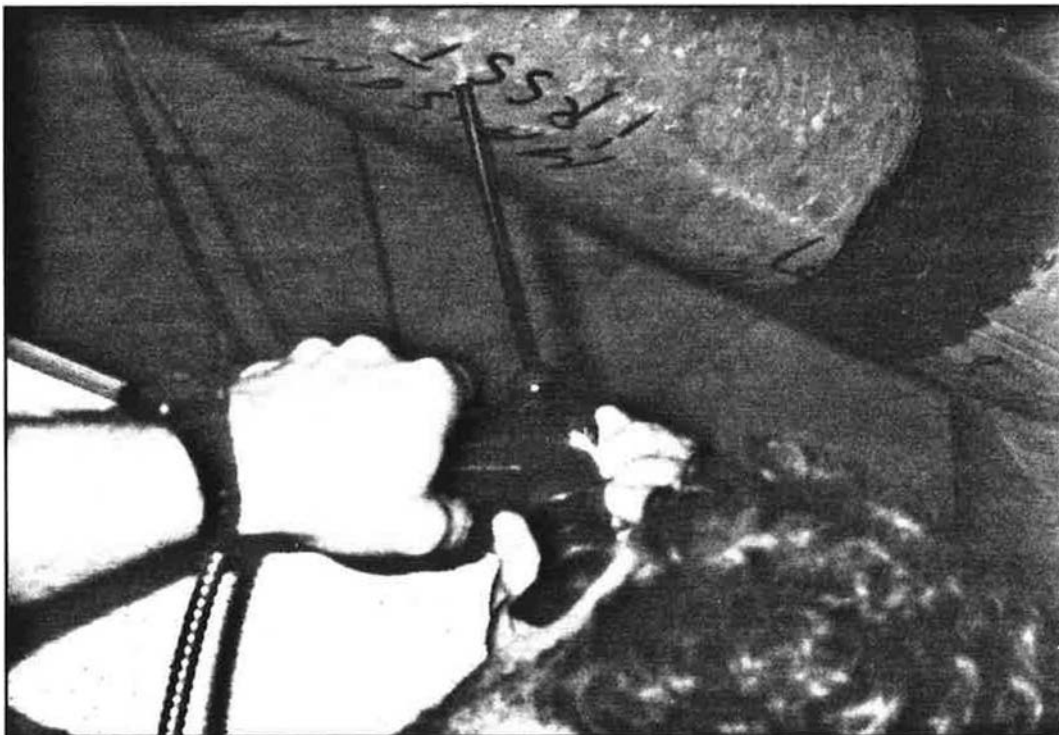

Figure 4.1: Rigid endoscope (borescope)



Table 4.1: Inspection checklist

Evaluator: _____

Date: _____

COMPONENT	CONDITION 1 to 4	ACCESSI- BILITY	ACTION TO BE TAKEN
Outdoor air			
Outdoor air intakes			
Filters			
Heating coils			
Cooling coils			
Dehumidification coils			
Mixing plenums			
Humidifiers			
Condensation pans and drains			
Fans			
Sound attenuators			
Heat exchangers			
Supply ducts			
Return ducts			
Terminal boxes			
Diffusers			
Return grills			
Indoor environment			
Mechanical room			
Peripheral units			
Other (1)			
Other (2)			

Level of cleanliness: 1 = Very clean 2 = Thin layer of dust 3 = Dirty 4 = Reduction in flow

Signature : _____

means of a plug. In other cases, a remote-controlled robot checks the cleanliness of the ducts. The filters must also be periodically checked. Damaged filters must be immediately replaced, particularly viscous-impingement filters whose efficiency decreases when there is no longer any viscous compound on the filter layer.

A detailed inspection of extended surface filters (figures 4.2 and 4.3) is necessary to detect signs of deterioration that can result from air turbulence, or from friction between the filters or from friction on other nearby components. For panel filters (figure 4.4), the side on which the filter was installed must be checked. This is indicated by an arrow or by a color on one of the two sides.

Ventilation system filters must be replaced at regular intervals. When a filter is clean, it is less efficient. As it becomes clogged, its filtering efficiency increases and the amount of air that

passes through it drops. It is suggested that filters be changed when the drop in static pressure has reached that recommended by the manufacturer, namely a value varying from two to three times the initial resistance. By recording the periodic static pressure readings in a log, one can determine the approximate date of replacement of the filters, as well as check that the pressure indicators are operating properly.

In variable air volume systems, the system must be operating at full capacity when the pressure readings are taken.

Filter replacement at the beginning of the summer and winter seasons is suggested, since during these periods, a high percentage of the air is recirculated. When the filters are replaced, it is recommended that the ventilation system be stopped to avoid particles being entrained. It is also suggested that the location be cleaned before installing the clean filters.

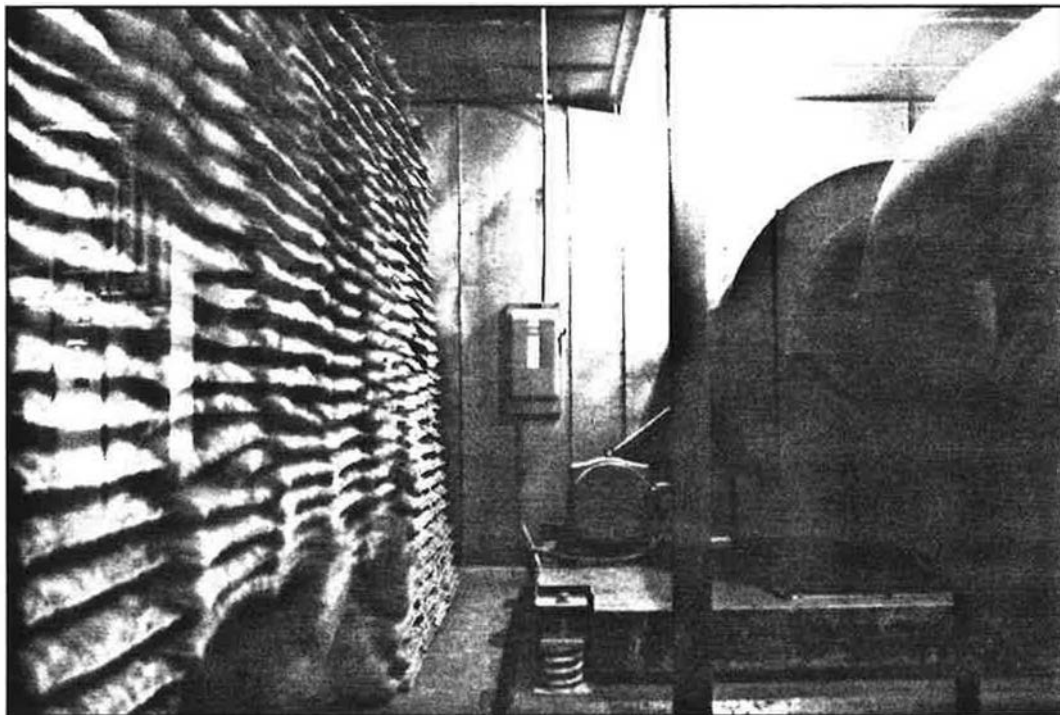

Figure 4.2: *Deterioration of bag filters from friction*

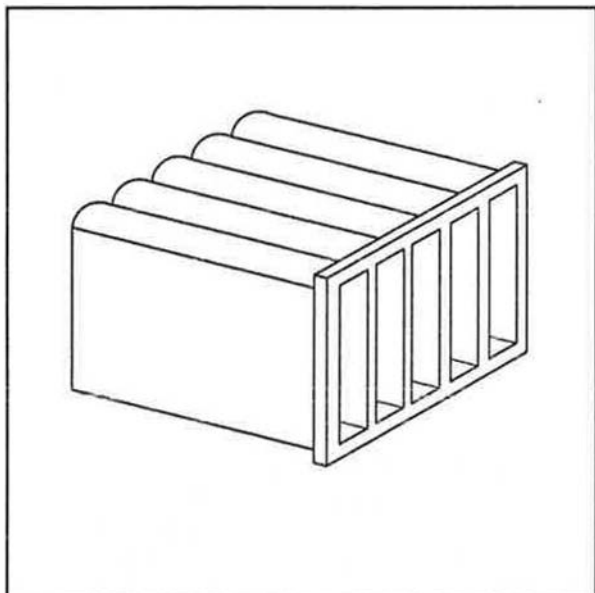

Figure 4.3: *Extended surface filter*

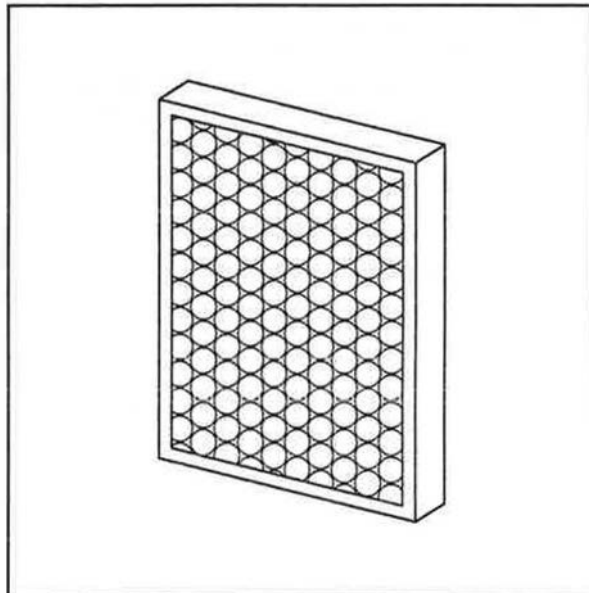

Figure 4.4: *Panel filter*

4.2 Sampling of microorganisms

A visual inspection of a building and its ventilation systems may identify one or more sources of microbial growth. The presence of one potential source of contamination should be sufficient to begin to immediately eliminate the problem. In fact, according to Burge (1990), it is more profitable to admit the existence of a bioaerosol-related problem and to recommend approved control measures than to wait for confirmation by air samples.

The standardized method, presented in the IRSST's Sampling Guide for Air Contaminants in the Workplace, uses the Andersen impactor or its modified N-6 version (figure 4.5). This impactor allows the size of the particles to be determined. The N-6 version consists of only one impaction stage and provides a general identification of the microorganisms found in the air at the time and place of sampling. Its sampling efficiency is comparable to that of the complete Andersen six-stage impactor.

The technique to be used, the precautions to be taken during sampling, as well as the counting and identification methods are also given in the IRSST guide. In short, as is described in figure 4.5, a known quantity of air inside an impactor is sampled. The microorganisms are collected on an appropriate culture medium located inside the impactor. The media are then incubated, at an optimum growth temperature and for a given time in the laboratory, to allow the colonies to develop. After the incubation period, the microorganisms are counted and identified using common microbiological methods. Counting is used to calculate the number of colony forming units per cubic metre of air (CFU/m³).

Other sampling methods exist for sampling bioaerosols. Table 4.2 presents a summary of the principles and applications of these samplers.

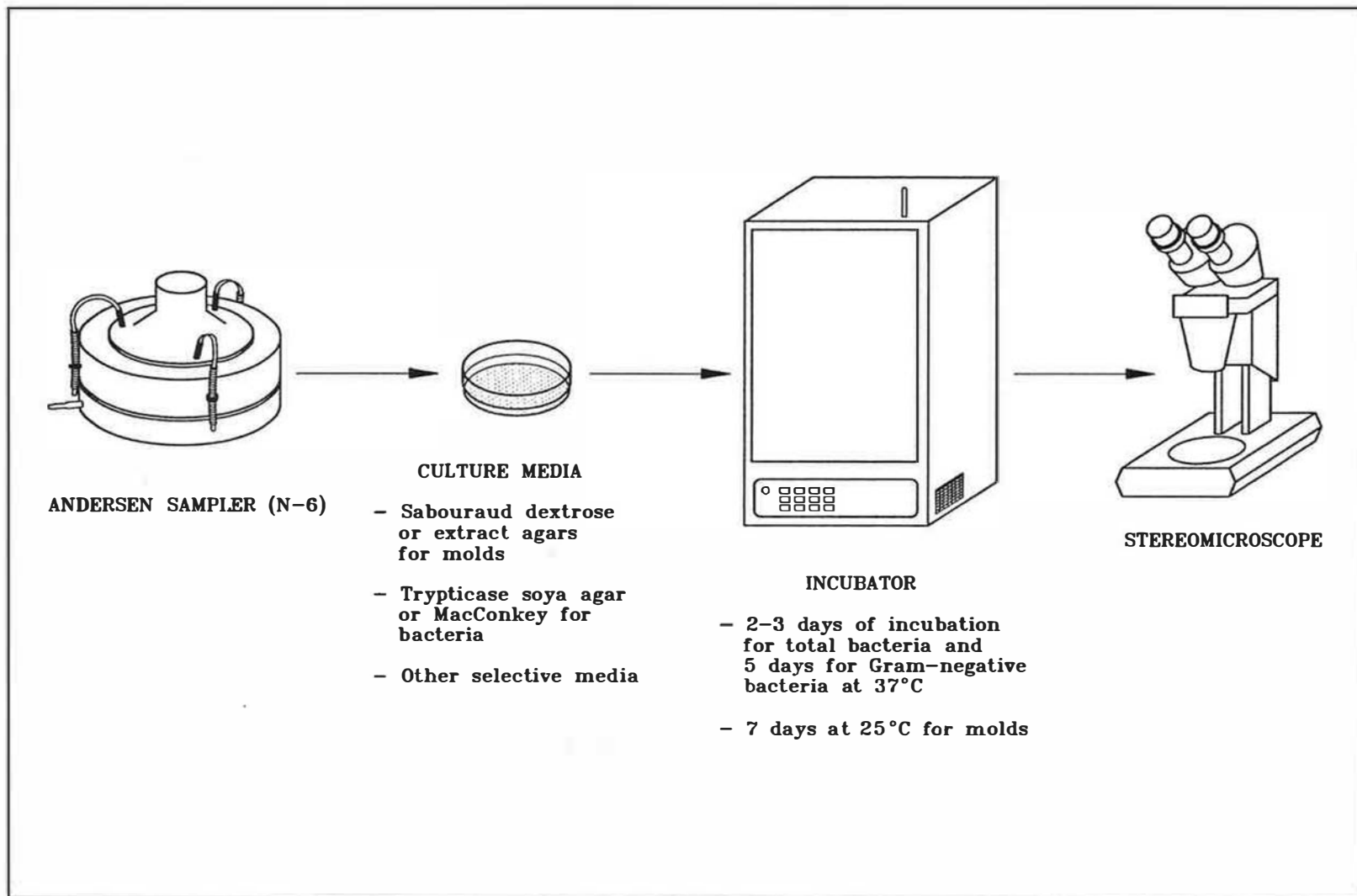

Figure 4.5: Sampling and analytical method used at the IRSST

Table 4.2: Samplers used in sampling viable bioaerosols (Chatigny et al., (1989))

SAMPLER	PRINCIPLE	APPLICATION
1. Impactors a) Andersen 1-stage (N-6) b) Andersen 6-stage c) Personal cascade impactor d) Portable impactor (SAS)	Impaction on an agar Impaction on agars Impaction on filters or special surfaces Impaction on a Rodac agar	Bacteria, molds and viruses at average to low concentrations. Samples the number of viable units. Same applications as 1 a). Gives the size of particles. Available in 8 stages. Useful only in highly contaminated environments. Portable. Useful in preliminary evaluations. The flow is difficult to measure.
2. Centrifuge sampler	Impaction on an agar	Portable and useful in preliminary evaluations. The flow is difficult to measure. Underevaluates particles smaller than 3 µm.
3. Sieve sampler	Impaction on an agar placed on a rotating surface	Provides information on bioaerosols as a function of time.
4. Filters a) Cassettes b) High-volume filters	Filtration Filtration	Possible loss of microorganisms due to drying of the filters. Useful for personal sampling. Rather inexpensive and portable.
5. Impingers a) Impinger AGI-30 b) Impinger AGI-4 c) Personal impinger d) Multi-stage impinger	Impingement into a liquid Impingement into a liquid Same principle as 5 a) Same principle as 5 a)	Same as 1 a). Excellent for highly contaminated environments. Same applications as in 5 a). Impingement is more vigorous. Same applications as in 5 a). Same applications as in 5 a). Gives the particle size.
6. Sedimentation	Deposit by gravity	Bias in the sampling of large particles.
7. Adhesive surface	Deposit by gravity	Method for identifying aeroallergens (ex. acarids).
8. Large-volume sampler	Electrostatic forces	45-90% efficiency of the AGI-30 or the Andersen impactor.
9. Spore trap	Impaction and deposit	Sampling of mold spores outdoors.

4.3 Guidelines

There is no standard in Québec and the United States regarding exposure to biological agents. The ACGIH document "Threshold Limit Values" (TLV) 1993-1994 stipulates that up to now, epidemiologic data are insufficient to describe the dose-effect relationship. The ACGIH Committee on Bioaerosols states that air quality is acceptable at the microbial level when the species of indoor populations (it is understood that indoor air includes the components of the ventilation systems and the workplace ambient air) and outdoor populations are the same and when the indoor concentrations are less or equal to those outdoors. This statement implies that outdoor air at the ventilation system's fresh air intake, if the latter is located at a reasonable distance from a source of contamination, must be taken as a control in all evaluations, particularly regarding fungal flora.

According to the National Air Duct Cleaners Association (NADCA), visual inspection is the first method for checking the cleanliness inside a ventilation system. If visible dirt remains after system cleaning, cleanliness is considered unacceptable. As a complement, there is another method for determining the cleanliness of systems in doubtful cases. It is a dust vacuuming method presented in the NADCA document. The weight of debris collected by the NADCA vacuum test must not exceed 1.0 mg/100 cm².

Bibliography on visual inspection and sampling

ACGIH.: Guidelines for the Assessment of Bioaerosols in the Indoor Environment. American Conference of Governmental Industrial Hygienists, Cincinnati, Ohio, 1989.

ACGIH.: Threshold Limit Values for Chemical Substances and Physical Agents and Biological Exposure Indices. 1993-1994. American Conference of Governmental Industrial Hygienists, Cincinnati, Ohio, 1992.

ASHRAE.: ANSI/ASHRAE Standard 52.1-1992. Gravimetric and Dust-Spot Procedures for Testing Air-Cleaning Devices Used in General Ventilation for Removing Particulate Matter. American Society of Heating, Refrigerating and Air-Conditioning Engineers, Atlanta, Georgia, 1992.

Botton, B., Breton, A., Fevre, M., Guy, Ph., Larpent, J.P., Veau, P.: Biotechnologies, moisissures utiles et nuisibles. Importance industrielle. Éditions Masson, 2^e édition, Paris, 364 p., 1990.

Burge, H.A.: Approaches to the Control of Indoor Microbial Contaminants. Proceedings of the ASHRAE Conference, Arlington, Virginia, pp.33-37, 1987.

Burge, H.: Bioaerosols: Prevalence and Health Effects in the Indoor Environment. J. Allergy Clin. Immunol., 86(5):687, 1990.

Chatigny, M.A., Macher, J.M., Burge, H.A., Solomon, W.R.: Sampling Airborne Microorganisms and Aeroallergens. In: Air Sampling Instruments for Evaluation of Atmospheric Contaminants. 7th ed., American Conference of Governmental Industrial Hygienists, Cincinnati, Ohio, 1989.

Collins, C.H., Lyle, P.M., Grange, J.M.: Microbiological Methods. 6th ed., Butterworths, London, England, 409 p., 1989.

Institut de recherche en santé et en sécurité du travail du Québec.: Sampling Guide for Air Contaminants in the Workplace. Méthode de laboratoires IRSST, 73 p., 1993.

Institute of Medicine of the US National Academy of Sciences.: Indoor Allergens: Assessing and Controlling Adverse Health Effects. National Academy Press, Washington, DC, 308 p., 1993.

Jones, W.G., Moring, K., Morey, P.R., Sorenson, W.G.: Evaluation of the Andersen Viable Impactor for Single Stage Sampling. Am. Ind. Hyg. Assoc. J., 46(5):294, 1985.

Kukkonen, E., Skaret, E., Sundell, J., Valbjorn, O.: Indoor Climate Problems. Investigation and Remedial Measures. Nordtest Report # 204, Espoo, Finland, 96 p., 1993.

Kundsinn, R.B.: Architectural Design and Indoor Microbial Pollution. Oxford University Press, New York, 317 p., 1988.

Larone, D.H.: Medically Important Fungi. A Guide to Identification. Elsevier Eds, 2nd ed., New York, 230 p., 1987.

Lavoie, J.: L'échantillonnage des microorganismes dans le milieu de travail. Direction des laboratoires, IRSST, 1988.

MacFaddin, J.F.: Biochemical Tests for Identification of Medical Bacteria. 2nd ed., Williams and Wilkins, New York, 527 p., 1980.

Mendell, M.J., Smith, A.J.: Consistent Pattern of Elevated Symptoms in Air-conditioned Office Buildings: A Reanalysis of Epidemiologic Studies. Am. Journ. Public Health (80)10:1193, 1990.

Morey, P.R.: Case Presentations: Problems caused by Moisture in Occupied Spaces of Office Buildings. Ann. Am. Conf. Govt. Ind. Hyg. 10:121, 1984.

Morey, P.R., Hodgson, M.J., Sorenson, W.G., Kullman, G.J., Rhodes, W.W., Visvesvara, G.S.: Environmental Studies in Moldy Office Buildings. NIOSH Report SF-86-09, No. 3, pp. 399-408, 1986.

Morey, P.R., Clerc, J.L., Jones, W.G., Sorenson, W.G.: Studies on Sources of Airborne Microorganisms and on Indoor Air Quality in a Large Office Building. Proceedings IAQ'86, pp. 500-509, ASHRAE, Atlanta, 1986.

Morey, P.R., Williams, C.W.: Is Porous Insulation Inside an HVAC System Compatible with a Healthy Building? American Society for Heating, Refrigerating and Air-Conditioning Engineers, IAQ 91, Healthy Buildings, Sept. 4-8, 1991.

Morey, P.R.: Controlling Microbial Contamination to Prevent Building-Related Illness and Remediation Costs. Clayton Environmental Consultants, Newsletter, 15(2):1, 1993.

NADCA.: Mechanical Cleaning of Non-Porous Air Conveyance System Components. National Air Duct Cleaners Association 1992-01, Washington, DC, 1992.

Ottney, T.C.: Particulate Management for HVAC Systems. ASHRAE Journal, July 1993.

Wagner, A.: Floor Coverings and IAQ: Health Impacts, Prevention, Mitigation and Litigation. Indoor Air Quality Update, Cutter Information Corp. eds., Arlington, MA, 78 p., 1991.

Washington, J.A.: Laboratory Procedures in Clinical Microbiology. 2nd ed., Spring and Verlag, New York, 885 p., 1985.

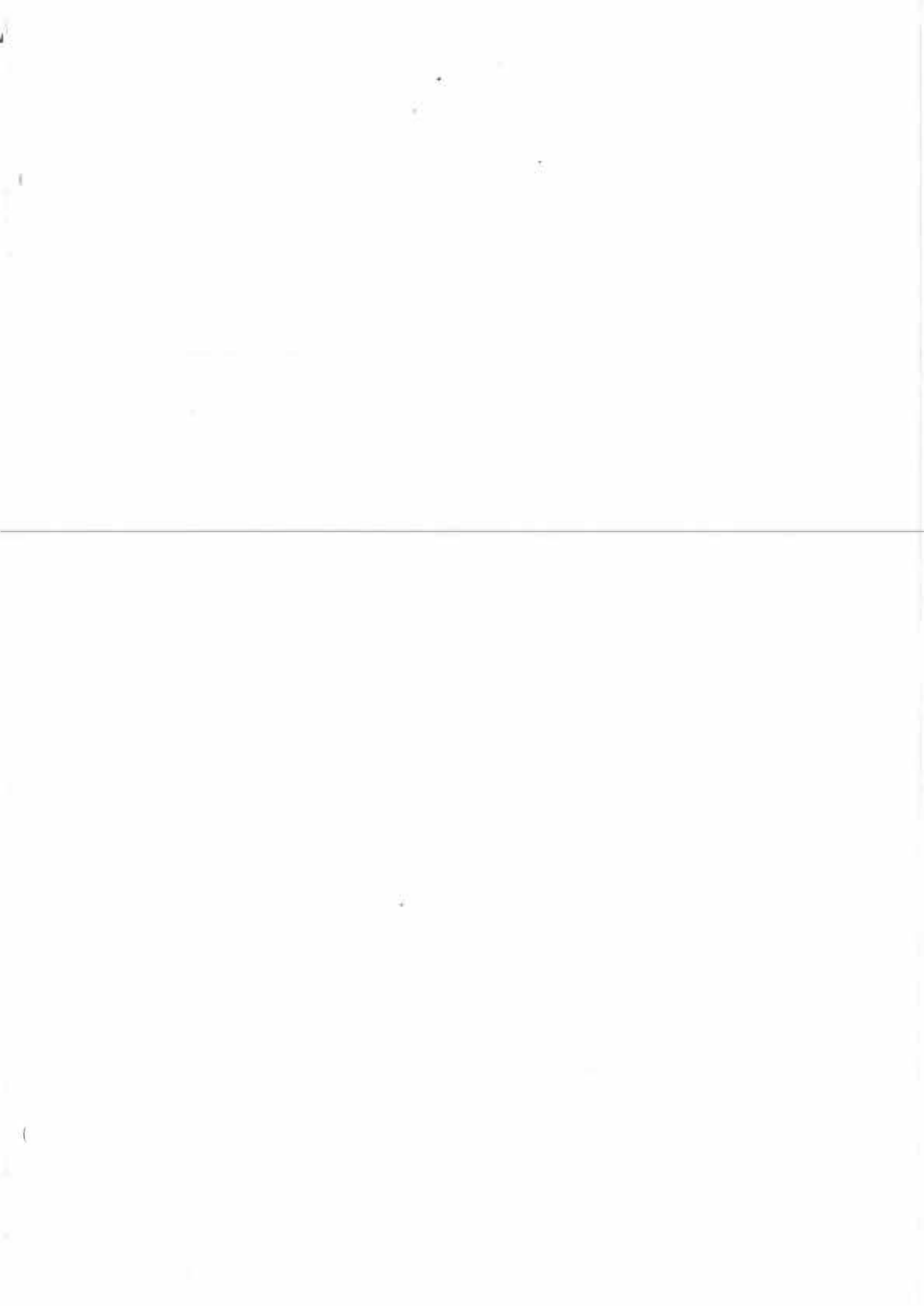



5. MAINTENANCE AND CONTROL PROCEDURES

Decontamination is an operation for eliminating the effects of chemical, biological or radioactive contamination of objects. At the biological level, decontamination is an operation that eliminates, kills, or inhibits the growth of unwanted microorganisms. The result is temporary and is limited to the microorganisms present during the operation.

The action taken to control the transmission of microorganisms to occupied areas must include the elimination of sources of water and carbon. Since all organic substances are sources of carbon, the elimination of sources of water remains the most effective solution.

The recommendations of the ACGIH Committee on Bioaerosols are:

- 1) Eliminate sources of water.
- 2) Eliminate sources of microbial growth.
- 3) Have an effective maintenance program.

Water infiltration must be eliminated as well as stagnant water in ventilation system components and in the outdoor environment. Porous materials damaged by water (furniture, tiles, carpets, etc.) must be replaced to effectively eliminate microbial contamination. A study carried out by Dybendel et al. (1990), among others, showed that 15 different detergents applied to contaminated carpets, even at concentrations higher than those recommended, have no destructive effect on the activity of the antigens and allergens tested.

5.1 Cleaning methods

5.1.1 Disinfectants

Clean all non-porous contaminated surfaces (i.e., drain pans, heating or cooling coils, fans, humidifier components) with a disinfectant. There are several different types of liquid disinfectants (biocides) on the market. They can be grouped into halogens (hypochlorites and iodine compounds), hydrogen peroxide, quaternary ammonium compounds, phenols, glutaraldehyde, alcohols and formaldehyde. The specific characteristics of these biocides are the following:

Halogens. Sodium hypochlorites are universal disinfectants, active against all microorganisms, including bacterial spores. Commercial bleach in a 1-5% aqueous solution is the disinfectant recommended by ACGIH (1989) for maintaining ventilation systems. It is a strong oxidizing agent, corrosive to metal. Sodium hypochlorite is the disinfectant recommended for general laboratory use. Hypochlorites kill microorganisms by enzymatic inactivation and interrupt the spore-germination process. This solution must never be mixed with concentrated acids or bases in order to avoid any rapid release of chlorine. The characteristics of chlorine and iodine are similar. Wescodyne solution is one of the iodine groups most used in the laboratory.

Hydrogen peroxide. Hydrogen peroxide also has disinfectant properties. A 3-6% concentration is recommended for disinfecting various materials. Note that at 25%, hydrogen peroxide is very toxic.

Quaternary ammonium compounds. Even after 40 years of tests, there is still a great controversy about the effectiveness of these compounds as disinfectants. They have the advantage of being odorless, noncorrosive, stable, inexpensive and relatively nontoxic. Benzalkonium chloride is a member of this family. These products are most effective against Gram-positive bacteria. Since certain Gram-negative bacteria such as *Pseudomonas* sp. can grow in benzalkonium chloride and cause infections, its use is questionable.

Phenols. Phenol homologs and phenolic compounds are the basis of several popular disinfectants. Since other safer and more powerful disinfectants are available, the use of phenolics has decreased over the last few years.

Glutaraldehyde. 2% glutaraldehyde is classified by the Environmental Protection Agency (EPA) as a high level disinfectant and sporicide. Glutaraldehyde is commonly used in hospitals and is safe when used according to instructions. However, glutaraldehyde is expensive and has a long action time for killing microorganisms, thus limiting its use.

Alcohols. Alcohols have been used as biocides for many years and continue to be used. The simplest aliphatic alcohols such as ethanol, propanol and isopropanol have excellent bactericidal properties. Alcohols can kill bacteria and viruses but are not effective against spores. They do not stain and are not corrosive. Alcohol (isopropanol) is most effective at a concentration of 70% by weight.

Formaldehyde. Formaldehyde can be used as a disinfectant. A concentration of 37% by weight of gas in water, with 10-15% methanol added to prevent spontaneous polymerization, is known as formalin. The very irritating odor of formaldehyde requires precautions. It is also a toxic irritant and a potential carcinogen; it must not be used in occupied areas.

Unfortunately, the most active disinfectants often have undesirable characteristics such as corrosive or irritant properties for humans. People assigned to cleaning must use personal protective equipment (rubber boots and gloves, respiratory masks for organic vapors and acid gases and equipped with HEPA filters, goggles, portable eye wash fountains, etc.). Specific precautions must be taken to ensure that the disinfectants or cleaners used are removed, i.e., rinsed and dried before start-up of the ventilation systems. An ideal disinfectant must be easy to use and have documentation on its effectiveness and its health effects. It must not damage materials. It must be nontoxic, nonirritating, nonallergenic, noncarcinogenic, nor cause congenital abnormalities. It must be odorless, and must act rapidly at low concentrations in the presence of debris and dirt. Up to now, there is no disinfectant that can meet these requirements. Table 5.1 taken from the ACGIH document (1989), summarizes the characteristics of these disinfectants.

This table shows that there are only a few disinfectants, such as aldehydes and halogens, that can inhibit bacterial and fungal spores, and often, more than one hour of contact is required. According to ACGIH (1989), the American EPA (Environmental Protection Agency) has not approved any biocide for use in humidifiers, clearly showing that their dissemination must not be permitted in occupied areas.

Table 5.1: Characteristics of some common biocides (ACGIH (1989))

BIOCIDES	SPORICIDAL ACTIVITY	MECHANISM	HUMAN HEALTH EFFECTS
Hypochlorites	Yes	Enzyme inactivation	Irritant, corrosive
Hydrogen peroxide solution	?	Hydroxyl-free	None for 3%
Quaternary ammonium compounds	?	Increase cell membrane permeability	Toxic irritants
Alcohols (ethanol, propanol and isopropanol)	No	Denatures proteins	None reported
Phenolics	No	Denatures protein	Odor, toxic irritant, corrosive
Glutaraldehyde	Yes	Protein cross-linking	Toxic irritant
Iodine, Iodophors	Yes	Iodination and oxidation of proteins	Skin, mucous membrane irritant
Formaldehyde	?	Binds DNA, cell proteins	Odor, toxic irritant, may be carcinogenic

5.1.2 Vacuuming of dirt

With dirt vacuuming, openings or access doors must be located where necessary, but without altering the flows. The North American Insulation Manufacturers Association (NAIMA) has produced recommendations on this.

During vacuuming, if the equipment recirculates the air in the room, the vacuums must be equipped with HEPA (High-efficiency Particulate Air) filters with a collection efficiency of 99.97% according to military test 282 of the American Department of Defense (DOP

(dioctylphthalate), 0.3 microns). If the vacuuming equipment is located outdoors, ensure that the emissions cannot be reintroduced into the building. There are several methods for cleaning ducts, whether insulated or not. The three main ones are:

- Contact vacuum method
- Air washing method
- Power brushing method.

Contact vacuuming

A portable vacuum is operated by applying the brush directly on the inside of the ducts to dislodge debris and dust. This method requires more openings and access doors because of the limited action radius. This process, which is not carried out under negative pressure, may leave particulate matter in the ducts which could then contaminate the ambient air. Figure 5.1 shows how the operation is performed. Once visual inspection has shown that the duct has been well cleaned, the brush is removed from the section and taken to the other openings where the process is repeated.

Air washing

Compressed air introduced into the duct dislodges dirt and debris which is collected in a collector located at the other end, thus generating a negative pressure in the section of the duct that is being cleaned (figure 5.2). It is recommended that the portion of the duct being cleaned be subjected to a minimum difference in static pressure of .025 kPa of water. The source of compressed air must be capable of producing between 1100 and 1400 kPa of pressure. This method is most effective for cleaning ducts smaller than 0.6 m X 0.6 m. When visual inspection indicates that the portion has been sufficiently cleaned, the compressed air pipe is removed from the duct and placed in the next opening located downstream.

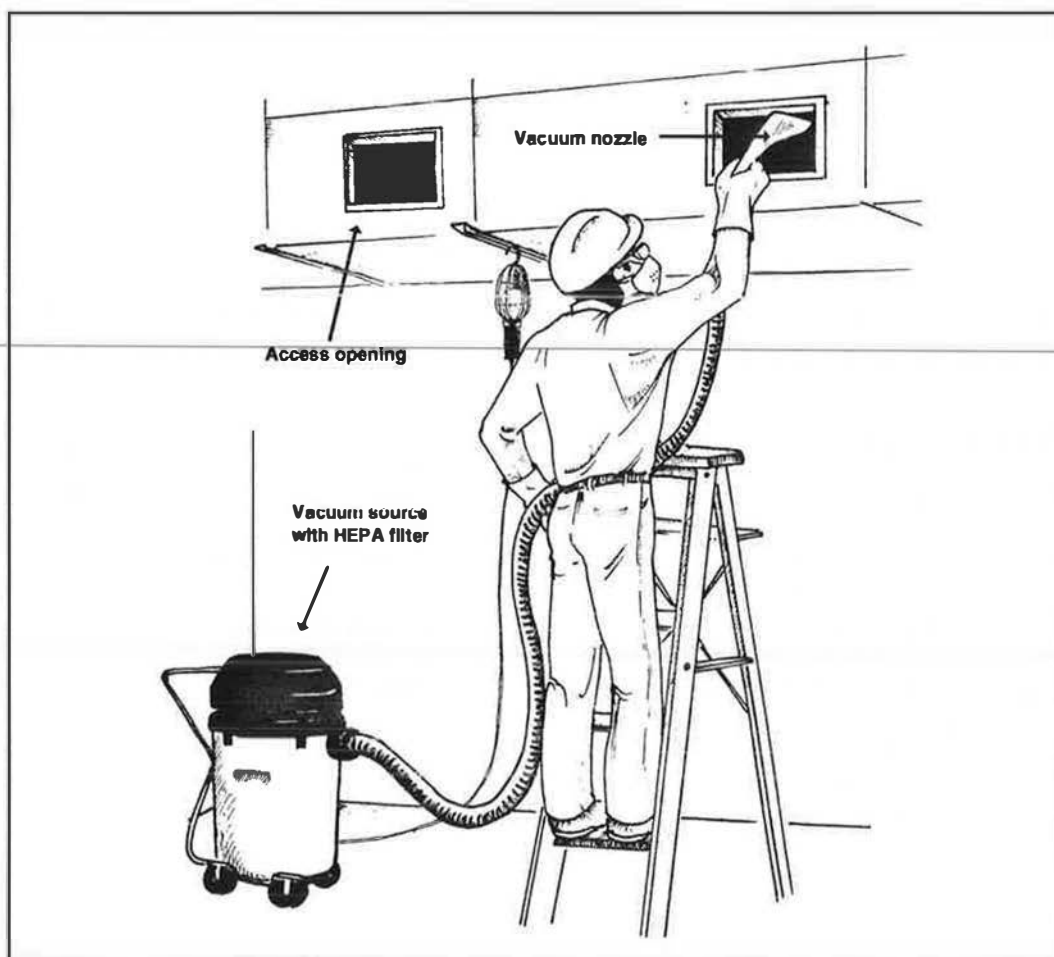

Figure 5.1: Contact vacuuming

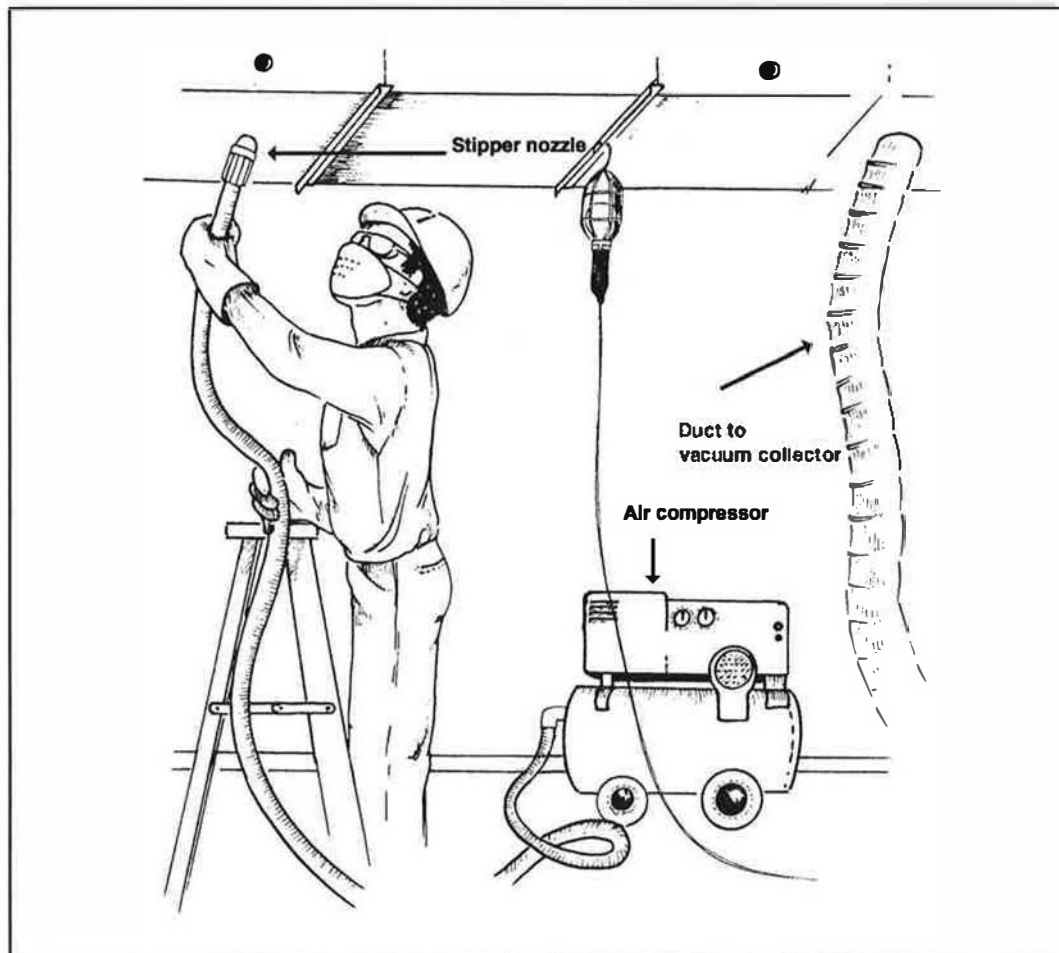

Figure 5.2: *Air washing method*

Power brushing

With this method, a rotating brush loosens the dirt or debris which is collected downstream in a collector similar to that used in air cleaning (figure 5.3). Precautions are necessary with this method in order to avoid damaging the surface of the insulation. Should this occur, the insulation must be immediately repaired. Only soft brushes can be used. This method seems to produce satisfactory results for all types of ducts and surfaces. The brushing time required is once again determined by visual inspection.

5.1.3 Other methods

Other methods, such as steam cleaning, are often used to clean uninsulated metal ducts and heating and cooling coils. According to NAIMA (1993), steam cleaning or any other system using water must not be used in an insulated duct. In fact, once insulation has become wet, it must be changed so that the thermal insulation and acoustic properties are maintained.

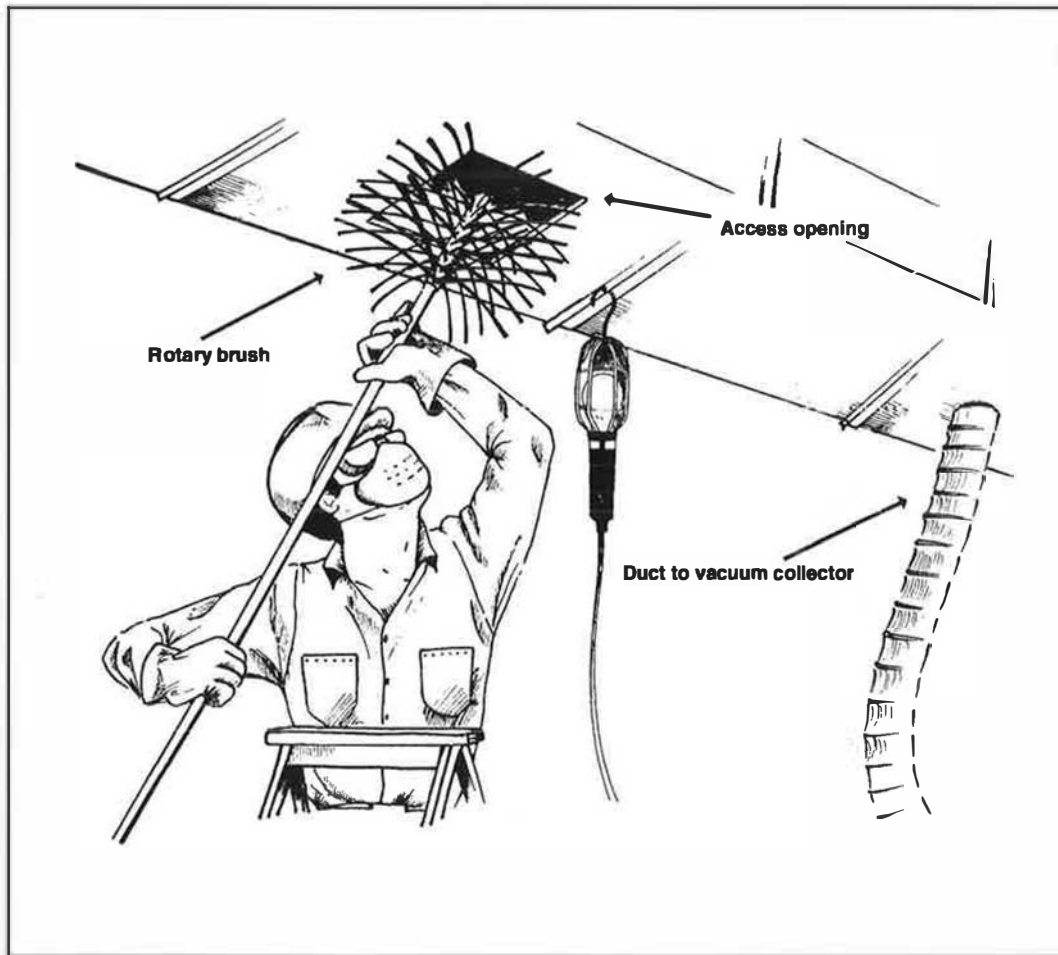

Figure 5.3: *Power brushing method*

Some cleaning companies propose the application of sealants inside ducts, whether insulated or not, in order to prevent the emission of debris or dirt into the air. These products are generally applied by spraying inside the ducts. According to NAIMA (1993), the effectiveness of this process is limited due to incomplete application on all duct surfaces. Also, these sealants modify the acoustic properties of the insulation, including flammability. Lastly, according to ACGIH (1989), these sealants, which consist of polymers, may contribute to the growth of microorganisms. As a result, NAIMA, the EPA, and NIOSH do not recommend their application.

Fumigation of the ducts is no more recommended than the application of sealants. In fact, for it to be effective against microorganisms, a substantial portion of the surface of the contaminated ducts must be treated, and there is only slight evidence that a sufficient amount of product is deposited deeply enough on the film of debris to have a disinfecting effect.

5.1.4 Work sequence

Duct cleaning must be carried out when the building is unoccupied, i.e., during the night or on weekends because the systems must generally be stopped during these operations. Figure 5.4 gives an example of the proper sequence, from 1 to 5, of the work. Specifications can also be used as a model in writing a cleaning contract and adapted to the specific requirements (table 5.2).

5.2 Preventive maintenance program

The purpose of a ventilation-system cleaning program is to keep all the components clean. This necessarily includes keeping surfaces free of mold by means of steam cleaning, disinfection (5% commercial bleach) or both.

According to some authors (Luoma, M. et al.), the optimum frequency of a complete ventilation-system cleaning program must be between 1 and 2 years, depending on the cleanliness of the outdoor air and the activities in the buildings. In practice, it is recommended that the cleaning

frequency be established by visual inspection. Also, it is logical to clean the components after use, namely the humidification and heating systems at the end of winter and the air-conditioning system after the summer.

The operation of the HVAC system is dependent on the control system operating properly. By comparing the temperature, humidity and pressure readings and the preestablished set points, a regulator transmits a correction signal in the form of electrical, electronic or pneumatic energy to one or more components of the system.

The control system components must be periodically checked and cleaned. Operating problems involving the control system generally result from the following:

- inadequate cleaning and calibration of the sensors;
- leaks in the air ducts, and premature wear of the electrical components due to vibration;
- improper initial design or installation;
- improper operating sequence;
- mechanical problems in the components to be controlled (motors, valves, actuators, dampers).

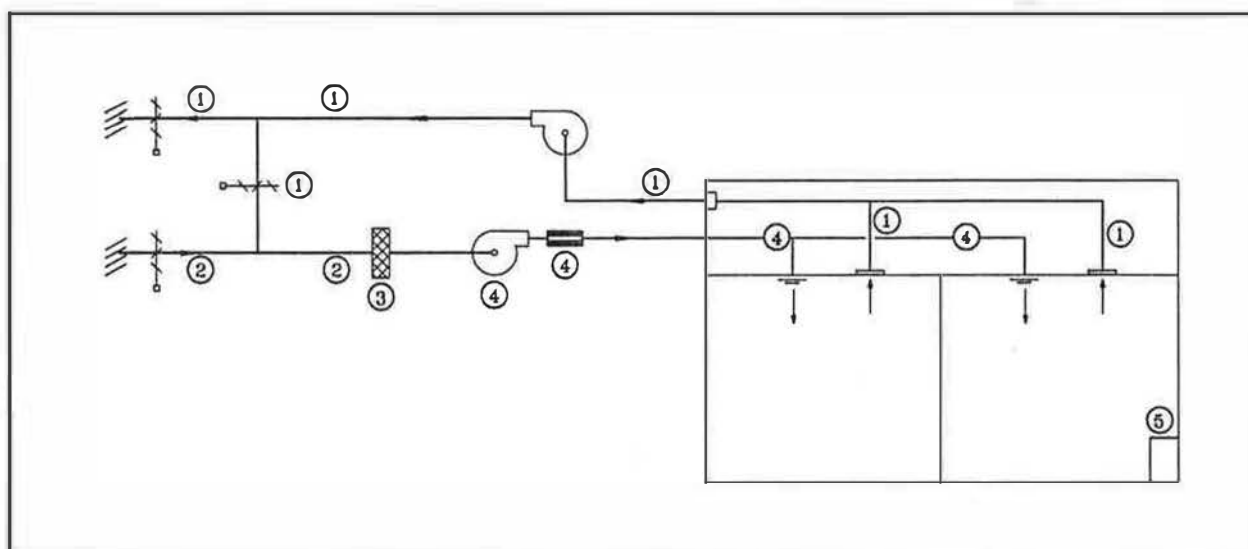

Figure 5.4: Cleaning sequence for ventilation system components

Table 5.2: Specifications for cleaning of ventilation ducts

CONTRACT : <i>Contract No.</i>	<i>Cleaning of ventilation ducts</i>	Section 15: _____ Page: _____ Date: _____
PART 1.0 – GENERAL:		
1.1 Scope of work	<ul style="list-style-type: none"> .1 The work consists of cleaning the air ducts in ventilation system <i>System no.</i> indicated on drawing <i>Reference no.</i> .2 Cleaning of the following components: fan(s), louver(s), exhaust fan(s), deflector(s), damper(s), coil(s), terminal box(es), flexible duct(s), humidifier, drain pan(s), heat exchanger(s), diffuser(s), grill(s). .3 The installation of access doors. .4 The dismantling of ceilings and their reinstallation, protection of equipment, protection and moving of furniture, and the protection of floors, partitions and other finishes. .5 The supply, placement and installation of all equipment for carrying out the work. .6 The repair and replacement of damaged acoustic and thermal insulation. 	
1.2 Related work	<i>Depending on the contract</i>	
1.3 Reference standards	<ul style="list-style-type: none"> .1 Mechanical Cleaning of Non-Porous Air Conveyance Components (NADCA 01). .2 Cleaning Fibrous Glass Insulated Air Duct Systems (NAIMA). .3 <i>Other standards.</i> 	
1.4 Cleaning program	.1 The Contractor shall supply with his tender the cleaning procedure selected, the equipment, the list of cleaning products and their safety data sheets.	

CONTRACT : *Contract No.* ***Cleaning
of ventilation
ducts***

Section 15: _____

Page: _____

Date: _____

PART 2.0 – EQUIPMENT AND PRODUCTS

- | | | | |
|-----|--|----|--|
| 2.1 | Cleaning products | .1 | The cleaning products for fans, coils, dampers and other components must be approved by the person awarding the contract (<i>name of person in charge</i>). |
| 2.2 | Access doors | .1 | Access doors shall be airtight and of the same gauge as the duct. |
| | | .2 | Access doors shall be prefabricated and adjusted to make them airtight using a gasket approved by the person awarding the contract. Acceptable product: <i>name of product</i> . |
| 2.3 | Insulation repair and replacement products | .1 | Acoustic insulation shall be repaired using the following product: <i>name of product</i> . |
| | | .2 | Thermal insulation shall be repaired using the following product: <i>name of product</i> . The insulation shall be covered by canvas such as the existing one. |
| | | .3 | Acoustic insulation shall be replaced using the following product: <i>name of product</i> . |
| | | .4 | Thermal insulation shall be replaced using the following product: <i>name of product</i> . |

PART 3.0 – EXECUTION

- | | | | |
|-----|--------------------------|----|--|
| 3.1 | Protection of personnel | .1 | The Contractor shall supply suitable protective equipment for the workers. |
| | | .2 | The Contractor shall obtain a certificate of solidity before entering the ventilation ducts. |
| 3.2 | Protection of components | .1 | The Contractor shall ensure that all the mechanical and electrical equipment located near the work is protected. |

CONTRACT : <i>Contract No.</i>	<i>Cleaning of ventilation ducts</i>	Section 15: _____
		Page: _____
		Date: _____
3.3 Access doors	<ul style="list-style-type: none"> .2 The Contractor shall refrain from placing, on the ductwork's thermal insulation, any objects, equipment, tools and materials that could damage it. .3 The Contractor shall avoid entering ducts when they are insulated inside. Protect the insulation if they must be entered. 	
3.4 Cleaning sequence	<ul style="list-style-type: none"> .1 Install access doors upstream and downstream from each bend or obstacle. .2 Install access doors every six (6) metres or as needed. .1 Cleaning shall take place from upstream to downstream in the air flow in the following sequence: <ul style="list-style-type: none"> .1 Stop the system. .2 Replace filters before starting the cleaning. .3 Clean from the return grills to the mixing plenum. .4 Clean from the fresh air intake to the coils. .5 Clean the coils. .6 Clean from the coils to the supply diffusers. .7 Clean the peripheral units. .8 Repair the insulation (thermal or acoustic) as the work progresses. .9 Replace the filter as needed. .10 Restart the system. 	

CONTRACT : *Contract No.*

***Cleaning
of ventilation
ducts***

Section 15: _____

Page: _____

Date: _____

- 3.5 Cleaning methods
 - .1 Ducts not insulated inside:
 - .1 Dry brushing, followed by cleaning with a vacuum equipped with "HEPA" filter.
 - .2 Loosening the dirt with compressed air using a nozzle, followed by cleaning with the vacuum equipped with "HEPA" filter.
 - .3 The use of products must be approved by the person awarding the contract.
 - .4 Do not apply sealant on the ducts.
 - .2 Ducts insulated inside.
 - .1 Dry brushing with soft brush followed by cleaning with vacuum equipped with "HEPA" filter.
 - .2 Do not wet the insulation.
 - .3 Do not use any soap, disinfectant or sealant on the insulation.
 - .3 Water drain pans.
 - .1 Empty and wash with a 5-6% sodium hypochlorite solution (bleach) at a concentration of 250 mL per 4 litres of water. Take into account the time needed to completely purge the vapors before starting the system.

- 3.6 Qualification
 - .1 The work shall be carried out by qualified people. The Contractor shall supply a list of similar work already carried out by the people selected.

- 3.7 Calibration dampers
 - .1 The Contractor shall mark the position of the dampers before cleaning and return them to the same position afterwards.

Bibliography on maintenance and control procedures

ACGIH.: Guidelines for the Assessment of Bioaerosols in the Indoor Environment. American Conference of Governmental Industrial Hygienists, Cincinnati, Ohio, 1989.

ASHRAE.: ASHRAE Standard 62-1989, Ventilation for Acceptable Indoor Air Quality. American Society of Heating, Refrigerating and Air-Conditioning Engineers, Atlanta, GA, 1989.

ASHRAE.: ANSI/ASHRAE Standard 52.1-1992, Gravimetric and Dust-Spot Procedures for Testing Air-Cleaning Devices Used in General Ventilation for Removing Particulate Matter. American Society of Heating, Refrigerating and Air-Conditioning Engineers, Atlanta, Georgia, 1992.

ASHRAE.: ASHRAE Handbook, HVAC Systems and Equipment. SI Edition, American Society of Heating, Refrigerating and Air-Conditioning Engineers, Atlanta, GA, 1992.

Block, S.S.: Disinfection, Sterilization and Preservation. Third edition, Lea and Febiger, Philadelphia, 1983.

Burge, H.A.: Approaches to the Control of Indoor Microbial Contaminants. Proceedings of the ASHRAE Conference, Arlington, VA, pp. 33-37, 1987.

Burge, H.A., Chatigny, M., Feeley, J., Kreiss, K., Morey, P., Otten, J., Peterson, K.: Bioaerosols. Guidelines for Assessment and Sampling of Saprophytic Bioaerosols in the Indoor Environment. Appl. Ind. Hyg., 2(5):R-10, 1987.

Burge, H.A.: Risks Associated with Indoor Infectious Aerosols. Toxicology and Industrial Health, 6(2):263, 1990.

Dybendal, T., Vik, H., Elsayed, S.: Dust from Carpeted and Smooth Floors-III. Trials on Denaturation of Allergenic Proteins by Household Cleaning Solutions and Chemical Detergents. Ann. Occup. Hyg., 34(2):215, 1990.

EPA-NIOSH.: Building Air Quality. A Guide for Building Owners and Facility Managers. Environmental Protection Agency and National Institute for Occupational Safety and Health, DHHS (NIOSH) Publication #91-114, Washington, DC, 1991.

Institute of Medicine of the US National Academy of Sciences.: Indoor Allergens: Assessing and Controlling Adverse Health Effects. National Academy Press, Washington, DC, 308 p., 1993.

Lavoie, J.: L'échantillonnage des microorganismes dans le milieu de travail. Étude/bilan de connaissances, Institut de recherche en santé et en sécurité du travail du Québec, Montréal, Québec, 73 p., 1988.

Lavoie, J., Comtois, P.: Décontamination microbienne des systèmes de ventilation. Rapport de recherche, Institut de recherche en santé et en sécurité du travail du Québec, Montréal, Québec, 30 p., 1992.

Lavoie, J., Comtois, P.: Microbial Decontamination of Ventilation Systems. Indoor Environ., 2:291, 1993.

Luoma, M., Pasanen, A.-L., Pasanen, P.: Duct Cleaning – A Literature Survey. Air Infiltration Review, Vol.14, #4, 1993.

Military Standard 282, 1956. United States Department of Defense (DOD), Washington, DC.

Morey, P.R.: Case Presentations: Problems caused by Moisture in Occupied Spaces of Office Buildings. Ann. Am. Conf. Govt. Ind. Hyg. 10:121, 1984.

Morey, P.R., Hodgson, M.J., Sorenson, W.G., Kullman, G.J., Rhodes, W.W., Visvesvara, G.S.: Environmental Studies in Moldy Office Buildings. NIOSH Report SF-86-09, No. 3, pp. 399-408, 1986.

Morey, P.R., Clerc, J.L., Jones, W.G., Sorenson, W.G.: Studies on Sources of Airborne Microorganisms and on Indoor Air Quality in a Large Office Building. Proceedings IAQ'86, pp. 500-509, ASHRAE, Atlanta, 1986.

Morey, P.R.: Controlling Microbial Contamination to Prevent Building-Related Illness and Remediation Costs. Clayton Environmental Consultants, Newsletter, 15(2):1, 1993.

NADCA.: Mechanical Cleaning of Non-Porous Air Conveyance System Components. National Air Duct Cleaners Association 1992-01, Washington, DC, 1992.

NAIMA.: Cleaning Fibrous Glass Insulated Air Duct Systems. Recommended Practice. North American Insulation Manufacturers Association, Alexandria, VA, 40 p., 1993.

Ottney, T.C.: Particle Management for HVAC Systems. ASHRAE Journal, July 1993, pp. 26-34.



6. PREVENTIVE MEASURES AND REGULATIONS

In order to prevent microbial growth in systems or reduce existing problems, various aspects must be considered in relation to system design and operation.

6.1 Outdoor air intakes

Outdoor air intakes must be located in such a way as to reduce the bioaerosols introduced from outside sources. The location must take into consideration various factors such as:

- the velocity and direction of dominant winds;
- the distance of nearby architectural and mechanical components;
- the configuration of the building in question and nearby buildings;
- the nature of the emissions from mechanical components;
- the presence of vegetation nearby;
- the risk of snow and rain accumulation at the louvers.

Determining a safe distance between the pollution sources and the air intake is a complex exercise that involves several parameters such as wind velocity, the height and geometry of the buildings, the development of zones under positive and negative pressure, emission characteristics, and the topography of the sites. Although there are some mathematical models and modeling techniques for evaluating the location of air intakes, they are generally underutilized.

In an existing facility, the risk of contamination from a nearby source can be evaluated by using a tracer gas or a smoke source. The tracer technique consists of generating a known concentration of a gas (such as sulfur hexafluoride (SF₆) or helium (He)) at a source of contamination, and

of determining the concentration at the fresh air intake. The use of a smoke source allows the migration of pollutants between their emission point and collection by the air intake to be visualized.

When an HVAC system is being designed, or when there is a problem with biocontamination, the following measures should be considered:

- take on the roof;
- do not locate the air intake at or below ground level;
- do not locate the air intake inside an architectural enclosure containing an evaporative condenser;
- maintain a minimum distance of 7.5 m between the sanitary vents and the air intake;
- correct nearby surfaces where water accumulation occurs or install drains;
- eliminate bird nesting sites;
- relocate waste-storage or snow-dumping sites away from fresh air intakes;
- evaluate the need for deflectors to prevent snow from entering the air intakes;
- install or modify louvers to limit rain penetration;
- install an indirect drain inside the intake to eliminate the water that enters;
- check the condition of the bird screen;
- check the location of evaporative cooling units and towers, and as needed, use deflectors to prevent water from being carried to the air intake;
- check periodically and control the microbial contamination of cooling towers;
- check the location of exhausts and change them as needed;
- ensure safe and easy access for equipment maintenance.

Regulations and standards

In Québec, the Regulation respecting the quality of the work environment (S-2.1,r.15) stipulates in section 22 that "the fresh air intake must be situated so that no air already evacuated from an establishment is reintroduced".

The National Building Code of Canada (1990) specifies that "exterior openings for outdoor air intakes and exhaust outlets shall be shielded from the entry of snow and rain".

In some municipal regulations, clearances may be specified. As an example and reference, regulation no. 4936 concerning building ventilation in the City of Montréal indicates in section 3 relating to outside openings, that the following minimum distances must be respected:

air intakes:

- 25 feet between a chimney outlet and the air intake;
- 7 feet between the lower edge of an air intake and the ground when the intake is in a wall adjacent to a public road and admits less than 3000 cfm, and 12 feet when more than 3000 cfm is admitted;
- 3 feet between the lower edge of an air intake and the ground when the air intake is in a wall ~~not adjacent to a public road;~~
- 3 feet between the lower edge of an intake and the ground when the intake is installed in a device resting directly on the ground;
- 18 inches between the lower edge of the air intake and the roof.

exhaust air outlets:

- 7 feet from the outdoor air intakes and preferably in the opposite direction;
- the exhaust outlets from bathrooms or garbage rooms venting at the roof must be in the opposite direction to the air intakes;
- 25 feet from the air intakes when the exhausted air contains suspended matter.

Furthermore, City of Montréal regulation no. 4515 concerning plumbing stipulates that a vent must not be located within 3 feet above or 12 feet in any other direction from an opening window, door, or any other similar opening.

The American Society of Heating, Refrigerating and Air-Conditioning Engineers (ASHRAE) specifies, in the standard entitled Ventilation for Acceptable Indoor Air Quality (ASHRAE 62-1989), that the outdoor air intakes must be located such that they are not contaminated by the exhaust air or other sources of pollution.

6.2 Mixing plenum

The mixing plenum must be designed in such a way as to provide a homogeneous mix of air flows in order to avoid stratification. This problem can generally be corrected by using deflectors. The return duct must preferably be connected to the plenum in parallel and over the entire length of the air intake. This promotes air mixing, and allows a uniform temperature to be obtained as well as an equal distribution of the flow at the filters and heat exchangers.

The plenum must be insulated in such a way as to prevent condensation from forming inside the chamber. Once the cause has been corrected, acoustic insulation must be replaced if it has become wet. An indirect drain may be required, depending on the design of the plenum. The height of the water seal should be at least 25 mm higher than the static pressure of the fan (minimum of 300 mm). A trap primer may also be required to ensure that water is always present.

The installation must be done in such a way as to provide easy access inside for inspection and maintenance, and the access doors must be built in an airtight manner.

6.3 Filtration

In HVAC systems, the filtration unit is generally one of the following: fibrous media unit filter, renewable media filter, electronic air filter, and a combination of several types. Filter selection is based mainly on the following criteria: the nature and concentration of the atmospheric pollutants, the degree of filtration required, and the characteristics under operating conditions, namely efficiency, resistance in terms of pressure loss, and the retention capacity.

The performance of an HVAC system is dependent on the filtration unit. With poorly maintained filters, flow resistance increases and the flow decreases. As we have previously seen, stratification in the mixing plenum could lead to unequal build-up on the filter surface, which could affect the reading of the differential manometer. Also, any change in the geometry or dimensions of the duct connections downstream and upstream from the filter section must be gradual in order to obtain uniform air distribution.

Suitable filters are difficult to select because of the ambiguity of the different tests originating from ASHRAE 52.1. In fact, the two test methods, namely the arrestance method and the dust spot method have been developed to measure the efficiency of filters of differing quality, with the first for low efficiency filters, and the second for those of average to high efficiency. Since the evaluation results are expressed as a percentage, it is important to specify in relation to which test the results were obtained. For example, an efficiency of 90% using the arrestance method is equivalent to an efficiency of approximately 20% using the dust spot method. Standard 52.1 is now being revised and should make filter classification uniform by basing the collection efficiency on particle diameter.

Table 6.1 indicates the contaminants retained in relation to the different filtration efficiencies.

This table shows that there are good reasons for using filters in the 80%-95% range, a percentage established using ASHRAE's dust spot method. In fact, according to Ottney (1993), all mold and pollen spores as well as 90% of bacteria are larger than 1 micron and these filters are 80 to 95% efficient in retaining them. To obtain more precise information or for more complex cases, the reader should consult the ASHRAE HVAC Systems and Equipment manual.

Some aspects must be carefully considered during filter installation or verification:

- a large wire bird screen at the air intake;
- the seal between the holding-frame hardware and the frame, particularly in plant-assembled units;
- the airtightness of access doors and the seals of joints around ducts, particularly downstream from the filter and upstream from the fan;
- the seal of all openings into electrical ducts and pipes;
- easy access and sufficient space (500 to 1000 mm) for filter replacement;
- a light source nearby;
- no water or snow accumulation;
- manometer operation and validity of reading.

Regulations and standards

ASHRAE standard 62-1989 specifies that filters and dust collectors must be selected in relation to the size of the particles and the concentration in the air. It also states that filters must be tested in compliance with ASHRAE standard 52-76 or MIL standard 282 of the U.S. Department of Defense.

Table 6.1: Comparison of filters ratings and applications (Adapted from Ottney, 1993)

APPROXIMATE RATINGS			TYPICAL APPLICATIONS AND LIMITATIONS	TYPICAL CONTAMINANT CONTROLLED	TYPICAL AIR FILTER TYPES
A	B	C			
99.97			Clean rooms Radioactive materials	Toxic dusts Viruses	HEPA and ULPA filters
80	98		Hospital inpatient care Smoking lounges	Bacteria Tobacco smoke	Fiberglass or synthetic media bag filters
50	90		Hospital laboratories Well-ventilated offices	Most bacteria	Box style filters, electronic air purifier
35	80		Office building ventilation	All pollens and oil smoke	Idem
	60		Paint boothse Welding fumes	Finer dusts Most pollens	Residential filters
	40	96	Commercial buildings	Most mold and spores	Pleated filters 1 to 4" thick
	25	93	Residential heating	Ragweed pollen	Disposable fiberglass, Polyester panels
		80	Window air conditioners	Coarse dust	Foam rubber
		65	Minimum filtration	Lint, etc.	Cleanable aluminum mesh
		50			Latex-coated animal hair

A = Percentage according to 0.3 micron particles of dioctylphthalate (DOP) (military standard 282, U.S. Department of Defense, 1956). This percentage is used for high efficiency filters, i.e., above 80%.

B = Dust spot efficiency percentage, ASHRAE 52.1-1992.

C = Arrestance percentage, ASHRAE 52.1-1992.

For information purposes, regulation no. 4936 of the City of Montréal indicates that the outdoor air of a system serving habitable rooms must be filtered (except industrial buildings), and that for offices, the filter efficiency must be 35% according to the dust spot method. It is also noted that filters whose capacity is greater than 5000 cfm must be permanently equipped with a manometer indicating the resistance across the filter. Finally, it mentions that when the resistance through the filters has doubled or reached the replacement value recommended by the manufacturer, the filters must be replaced or cleaned, depending on the case.

6.4 Cooling coil

Various solutions for limiting water entrainment can be considered. However, the source of the problem needs to be determined beforehand. If the problem is due to system design, it may be related to too high a face velocity at the coil (greater than 3 m/sec.), and in this case, a water eliminator can be used to collect the water and prevent the the acoustic insulation from getting wet.

If the problem has appeared over the years, without there being modifications to the HVAC system, it may be due to a build-up of dirt on the coil, which leads to an increase in the air velocity. In this case, it is recommended that periodic readings of the pressure difference across the coil be taken to establish the cleaning frequency. Water entrainment may also result from an increase in the flow of outdoor air to be treated, following a malfunction of the outside air intake.

The drain pan for condensation water must be designed and installed in such a way as to prevent water from collecting. The drain must be located at the bottom, at the lowest point in the pan, and equipped with a deep water seal whose height is 25 mm above the static pressure of the

fan (minimum of 300 mm) and connected indirectly, with a slope of 2% (20 mm/m), to the drainage network. A trap primer can be installed to prevent evaporation of the water seal. There must be no insulation on the inside or outside of the pan. When cooling coils are located one over the other and the total height is more than 1.1 metres, it is preferable to install an intermediate drain pan whose minimum length is equal to half the height of the coil. This length must be increased when the velocity is greater than that recommended.

When the air is dehumidified by the cooling coil, the relative humidity of the air downstream is generally between 90% and 100%. When there is acoustic insulation, it is recommended that it be kept dry and free of dust. As needed, insulate the outside of the unit and use a sound attenuator to lessen the noise, and install an airtight door nearby for easier access for maintenance.

Regulations and standards

Concerning the drainage of condensation water from the drain pan or any other drain connected to a ventilation unit, the province of Québec's plumbing code specifies that if there is a risk of evaporation of the trap, a seal that can withstand all positive or negative pressure, and with a minimum height of 300 mm, must be installed and indirectly connected to the drainage network. ASHRAE standard 62-1989 indicates that the drain pan must be designed to drain and prevent the accumulation of deposits.

ASHRAE standard 62-1989 mentions in article 5.6 that ventilation ducts and plenums must be built and maintained in such a way as to minimize the growth and dissemination of microorganisms in the ventilation system. Article 5.11 also mentions that the humidity of habitable rooms should be between 30% and 60% to minimize the risk of growth of allergenic or pathogenic organisms. Article 5.12 mentions that if the humidity is greater than 70% in habitable rooms, low-velocity ventilation ducts and plenums, there is a risk of fungal contamination.

To clarify the interpretation of these articles, the committee responsible for developing the standard wrote in a technical note that article 5.6 is obligatory, while articles 5.11 and 5.12 are advisory in nature, to let the user know about conditions supporting contamination, the importance of controlling the humidity using appropriate means, and the need for minimizing nutrient sources.

It is furthermore indicated that article 5.6 is not intended to prevent the use of acoustic insulation inside ducts, but rather to encourage the use of techniques that do not support the growth of microorganisms. In this respect, the use of acoustic insulation in ducts must be limited, and proper filtration must be planned upstream from the components covered with acoustic insulation. It is also mentioned that a physical barrier must be used to protect the insulation, rather than a chemical sealant or one with disinfectant properties (these products could become aerosolized). The installation of access doors for cleaning the inside of ducts is recommended.

6.5 Humidifiers

Steam humidification is recommended in most technical publications dealing with indoor air quality. However, when the steam is generated by a central boiler, precautions must be taken to avoid contaminating the air with the chemical additives used for treating the water to prevent scale formation or corrosion. There are various technical means of avoiding this problem and each one must be analyzed by a specialist in relation to its feasibility and profitability.

With atomizing humidifiers, whose use in HVAC systems is relatively recent, only periodic follow-up will precisely determine the risks related to their use. As a preventive measure, periodic purging of the treated water tank is suggested.

Air washer humidifiers are not recommended and existing equipment must be rigorously and frequently cleaned. The addition of biocides is not indicated due to their limited effectiveness against microbes and their potential toxicity for building occupants. Scale deposits must also be removed in order to reduce porous surfaces.

According to BSRIA (1986), (Building Services Research and Information Association), air washer humidifiers using recirculated water should be equipped with an automatic purge system that allows the system to be rinsed and emptied every hour outside the hours of operation.

In an attempt to correct the biocontamination problem, some air washers are equipped with a light that emits ultraviolet radiation, which is inserted in the water recirculation network. The dose of ultraviolet radiation emitted by this light is generally greater than 30.000 mW.sec/cm² and the wavelength is approximately 254 nm. Normal wear on the lamp or the formation of an opaque film on the lamp's protective sleeve, resulting from the precipitation of the metals dissolved in the water, may reduce the intensity of the radiation. With some installations, film formation may be limited by filtering or softening the water, which could, however, result in corrosion problems. Also, a filter is needed to collect the suspended solid particles whose presence may cause a shadow effect. An intensity indicator is required to ensure a sufficiently high level of radiation. Although UV lamps are used extensively in the treatment of drinking water, no specific study has dealt with their use in air washers.

Independent of the type of humidifier and its location, the water vapor introduced into a flow of air must be absorbed without risk of condensation. An interlock mechanism must be included to avoid simultaneous humidification and dehumidification. An access must be provided for periodic checking and maintenance.

Regulations and standards

According to the Québec plumbing code, the drains of humidifiers or drain pans must be equipped with a water seal of a minimum height of 300 mm and connected indirectly to the drainage network. The water seal must be able to withstand all positive or negative pressure.

According to article 5.12 of ASHRAE standard 62-1989, steam humidification is preferable, and care must be taken not to contaminate the water in the boiler or the steam with chemicals. The cold water used for humidification must come from a source of drinking water. Also, if the water is recirculated, which is the case for air washers and some atomizing humidifiers, the system must be frequently cleaned and purged.

6.6 Air supply and return ducts

The need for insulating ventilation ducts is dictated by different parameters, particularly: their indoor or outdoor location, the energy impact in terms of the heating and cooling capacity as well as the operating costs, the risk of condensation in ducts carrying air at low temperature, maintaining a stable temperature in the ducts, and noise control by using inside insulation.

Due to its potential for contamination and its cleaning difficulties, porous insulation is not recommended inside ventilation ducts. Any other means of noise reduction should be favored. The installation of sound attenuators at the fan outlet are generally effective for reducing the noise generated by the fan. In the latter case, an access door must be provided nearby for inspection and cleaning. Even with a sound attenuator, it may be necessary to insulate the inside end of the ductwork, over a distance of several metres, to absorb the noise generated by the moving air. By insulating this part of the duct, noise transmission from one room to the next can be eliminated. Since this section is not likely to become wet, porous insulation is less problematic and can easily and periodically be checked.

Specific attention must be paid to ventilation ducts exposed to cold temperatures, which require suitable thermal protection and a vapor barrier.

Regulations and standards

ASHRAE's recommendations concerning the presence of insulation inside ventilation ducts were discussed in section 6.4.

6.7 Indoor sources of contamination

Relative humidity can be defined as the mass of water vapor present in the air, expressed as a percentage of the maximum mass of water vapor that the air can hold at that same temperature. When the temperature changes, the relative humidity also changes, since the ability of the air to hold water vapor increases with temperature, and inversely, decreases when the temperature drops.

Moisture is introduced into a building by the ventilation and humidification systems, by infiltration or diffusion through the building envelope, or naturally, by the people present.

Water vapor is carried through the building envelope mainly by the air that infiltrates through openings. This infiltration is the result of the different pressures exerted on the envelope, namely: wind pressure, and the draft and pressure effect due to the ventilation system. To a lesser extent, vapor may also migrate by diffusion, going from the highest pressure to the lowest. As an example, in a heated room where the vapor pressure is greater than the outdoor vapor pressure, humidity will be seen to move outwards. However, in summer in an air-conditioned building, the opposite situation occurs and the vapor in the outdoor air moves inwards.

Water can also enter the envelope in liquid form. Rain, for example, when it hits an outside face, is subjected to several forces that promote its movement. Capillary force, impulsive force, weight and wind thrust are important parameters in the penetration of water through the envelope. This action is increased in the case where a component such as a window is not watertight, thus allowing the infiltration of significant amounts of water.

6.7.1 Surface condensation

When the water vapor content of the air reaches the saturation point (the relative humidity is 100%), the water vapor condenses, going from the gaseous to the liquid state. Consequently, in a room, any surface whose temperature corresponds to the dew point for the humidity will make the nearby water vapor condense.

Problems with surface condensation occur when the walls of a building that are directly exposed to humidified air from inside are maintained at a temperature below the dew point.

For example, when the relative humidity is high, there may be problems with condensation on the masonry surfaces located below ground level. Since the surface temperature remains relatively stable and comparable to that of the ground, condensation could occur. This problem is generally corrected either by dehumidifying the air in the room or by insulating the outside surface of the wall, thus keeping the wall at a temperature above the dew point of the air. In some cases, it may be easier to insulate the inside surface of the wall, taking care to protect the insulation with a vapor barrier. This approach, however, could promote the formation of hidden condensation.

In winter, condensation may appear on an inside surface of a poorly insulated wall or result from the presence of a thermal bridge (figure 6.1). A thermal bridge occurs when a component of the building offers less resistance to heat loss than the main structure, and often consists of the beams or the steel or concrete piles incorporated into the outside parts of the walls or roof. When the temperature of part of a surface is maintained below the dew point, dirt particles can accumulate. Insulation of the structural component is then required.

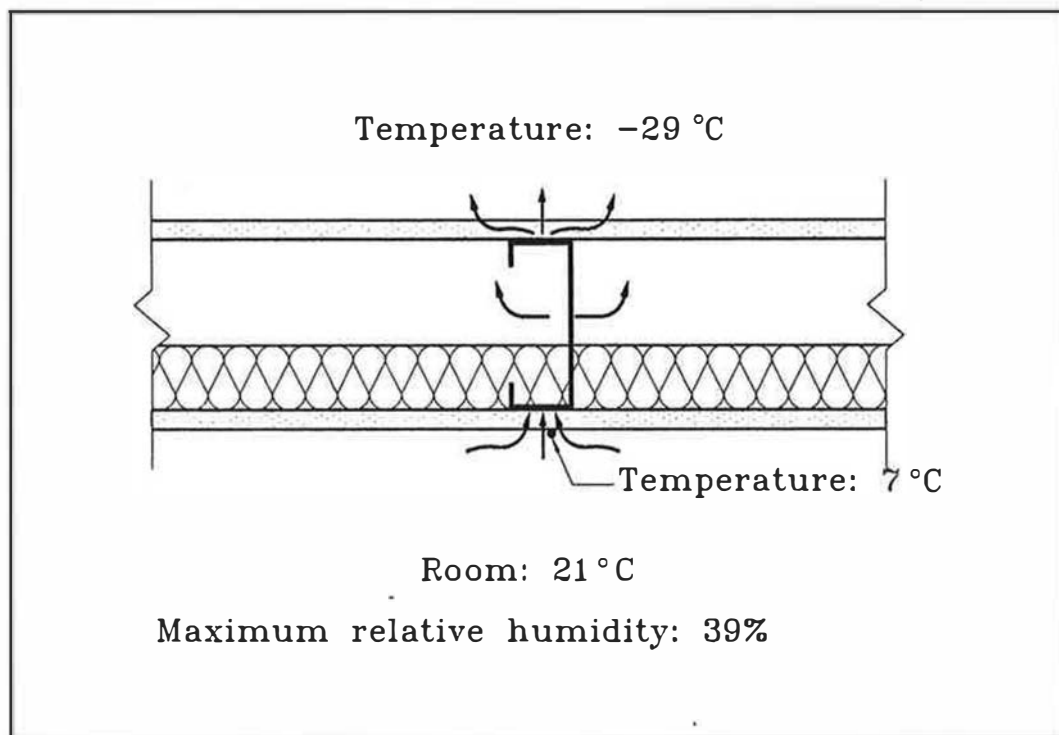

Figure 6.1: Thermal bridge created by a steel beam

Windows, due to their low thermal resistance, are particularly susceptible to condensation of the humidity in the air. If the windows are not changed, condensation can be reduced by lowering the humidity in the room, and in some cases, by improving air circulation.

In some buildings, as a means of saving energy, the temperature is lowered at the end of the day. If the temperature is too low, visible condensation may form on the surfaces of the rooms.

6.7.2 Hidden condensation

Should moisture, in crossing the building envelope, come in contact with a surface whose temperature is below the dew point of the air-vapor mixture (figure 6.2), condensation will occur. If this is not removed, the water that accumulates may cause the degradation of the construction materials and promote the development of mold and bacteria. Problems of this nature are generally corrected by improving the tightness of the envelope, and in some situations, by modifying the temperature gradient by means of insulation.

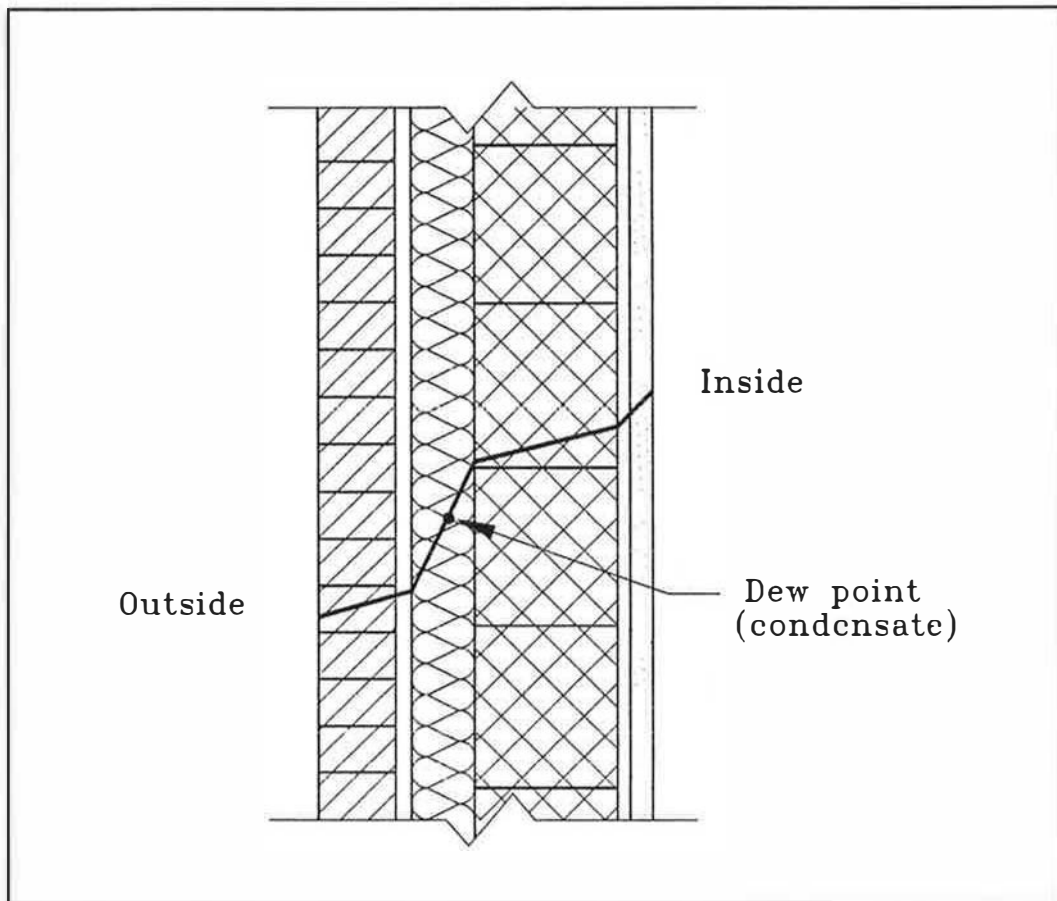

Figure 6.2: *Temperature gradient during winter*

A problem related to hidden condensation could occur during air-conditioning periods when the humidity from an outside source crosses the building envelope and condenses on a surface cooled by the room's air-conditioning. In the case of a gypsum wall, the material will soften, crumble, and mold will appear on its surface. The problem could be accentuated with a material with low permeability, such as vinyl-based wall paper, which prevents the vapor from passing through and results in water accumulation between the gypsum wall and the cladding.

6.7.3 Controlling humidity

Problems such as those described above require an understanding not only of the temperature and humidity conditions, but also of the interrelationship of these parameters with the architectural components of the building. Because of the complex nature of the water-vapor diffusion mechanisms in a building, the services of professionals may be necessary to determine the source of the humidity and the proper means of controlling it.

Bibliography on preventive measures and regulations

AQME.: Guide pratique d'entretien pour une bonne qualité de l'air intérieur. Association québécoise pour la maîtrise de l'énergie, 1989.

ASHRAE.: ASHRAE Handbook. HVAC Systems and Equipment. SI Edition, American Society of Heating, Refrigerating and Air-Conditioning Engineers, Inc., Atlanta, GA, 1992.

ASHRAE: Technical Data Bulletin Control of Humidity in Buildings. American Society of Heating Refrigerating and Air-Conditioning Engineers, Inc., Atlanta, GA, 1992.

ASHRAE.: ASHRAE Handbook. HVAC Applications. SI Edition, American Society of Heating, Refrigerating and Air-Conditioning Engineers, Inc., Atlanta, GA, 1992.

ASHRAE.: ASHRAE Standard 62-1989. Ventilation for Acceptable Indoor Air Quality. American Society of Heating, Refrigerating and Air-Conditioning Engineers, Atlanta, GA, 1989.

ASHRAE.: ASHRAE Handbook. Fundamentals. SI Edition, American Society of Heating, Refrigerating and Air-Conditioning Engineers, Inc., Atlanta, GA, 1992.

City of Montréal.: Règlement concernant la ventilation des bâtiments dans la ville de Montréal, No. 4936, 1975.

EPA-NIOSH.: Building Air Quality. A Guide for Building Owners and Facility Managers. Environmental Protection Agency and National Institute for Occupational Safety and Health, DHHS (NIOSH) Publication #91-114, Washington, DC, 1991.

Government of Québec.: Code de plomberie, I-12.1, r.1, avril 1986.

Government of Québec.: Règlement sur la qualité du milieu du travail S-2.1, r.15, février 1990.

Haines, R.W.: Control Systems for Heating, Ventilating and Air Conditioning. Third Edition. Van Nostrand Reinhold Company Inc. 305 p., 1983.

Kundsin, R.B.: Architectural Design and Indoor Microbial Pollution. Oxford University Press, New York, 317 p., 1988.

Latta, J.K.: Murs, fenêtres et toitures pour le climat canadien. National Research Council of Canada, Ottawa, 92 p., 1975.

Legg, R.: Air Conditioning Systems. B.T. Batsford Ltd, London 415 p., 1991.

Melson, G.: When Drain Pans Don't Drain. Environment 2(4):2, 1993.

Morey, P.: Controlling Microbial Contamination to Prevent Building-Related Illness and Remediation Costs. Clayton Environmental Consultants, Newsletter, 15(2):1, 1993.

National Research Council of Canada: National Building Code of Canada 1990. National Research Council of Canada, Ottawa.

National Research Council of Canada: Digests de la construction au Canada 1 à 150. National Research Council of Canada, Ottawa, 1975.

Ottney, T.C.: Particle Management for HVAC Systems. ASHRAE Journal, July 1993.

Pickering, C.A.C., Jones, W.P.: Health and Hygienic Humidification. The Building Services Research and Information Association, Berkshire, 1986.

Stewart, L.J.: Micro-organisms in Building Services. The Building Services Research and Information Association, Berkshire, 1988.

CONCLUSION

The following figure is a summary of the main aspects covered in this document.

This guide covers the parameters involved in the development of conditions favorable for microbial growth as well as the means of eliminating them. By including them in one document, we hope that we have provided the reader with the information necessary for detecting and preventing problem situations.



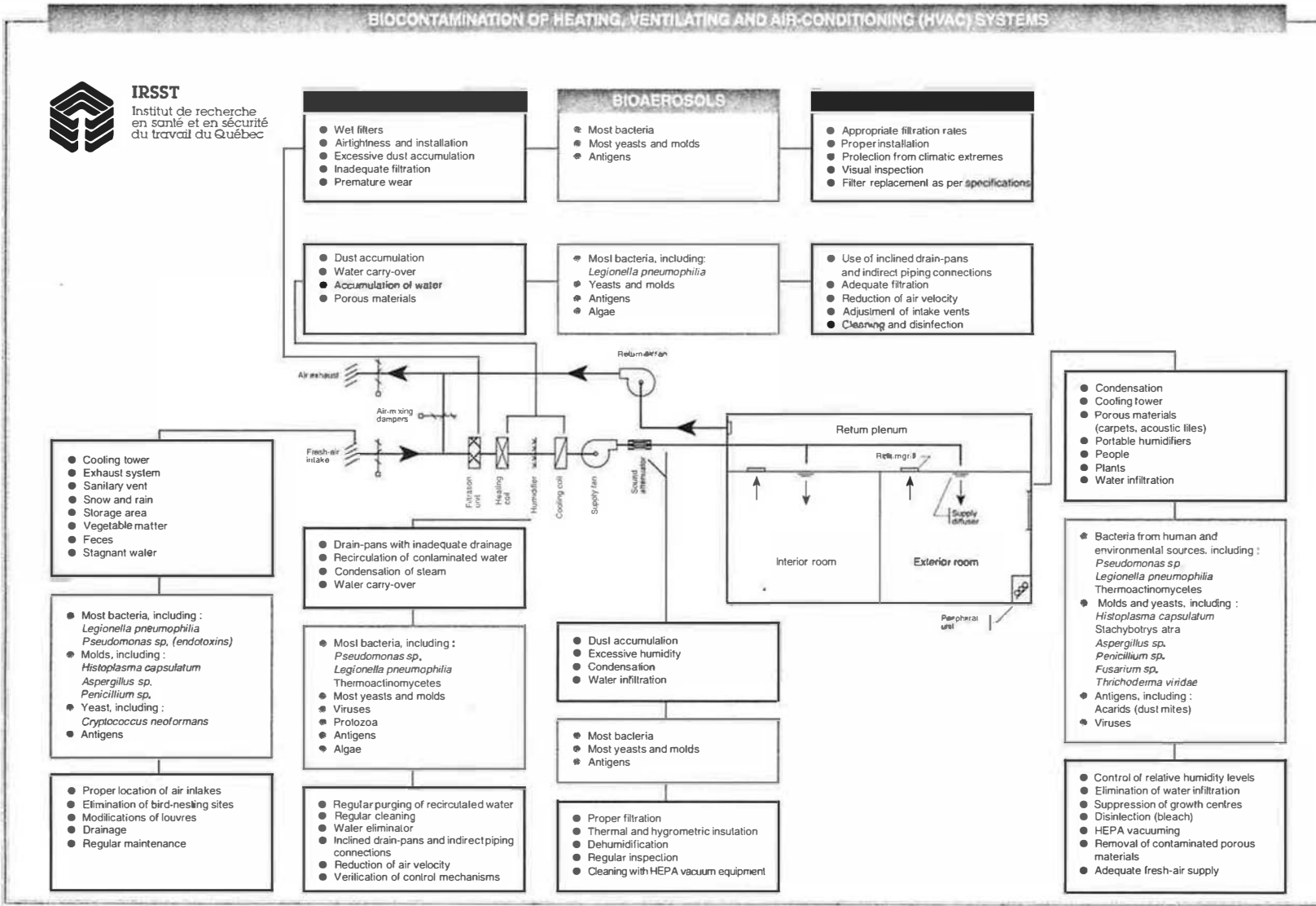

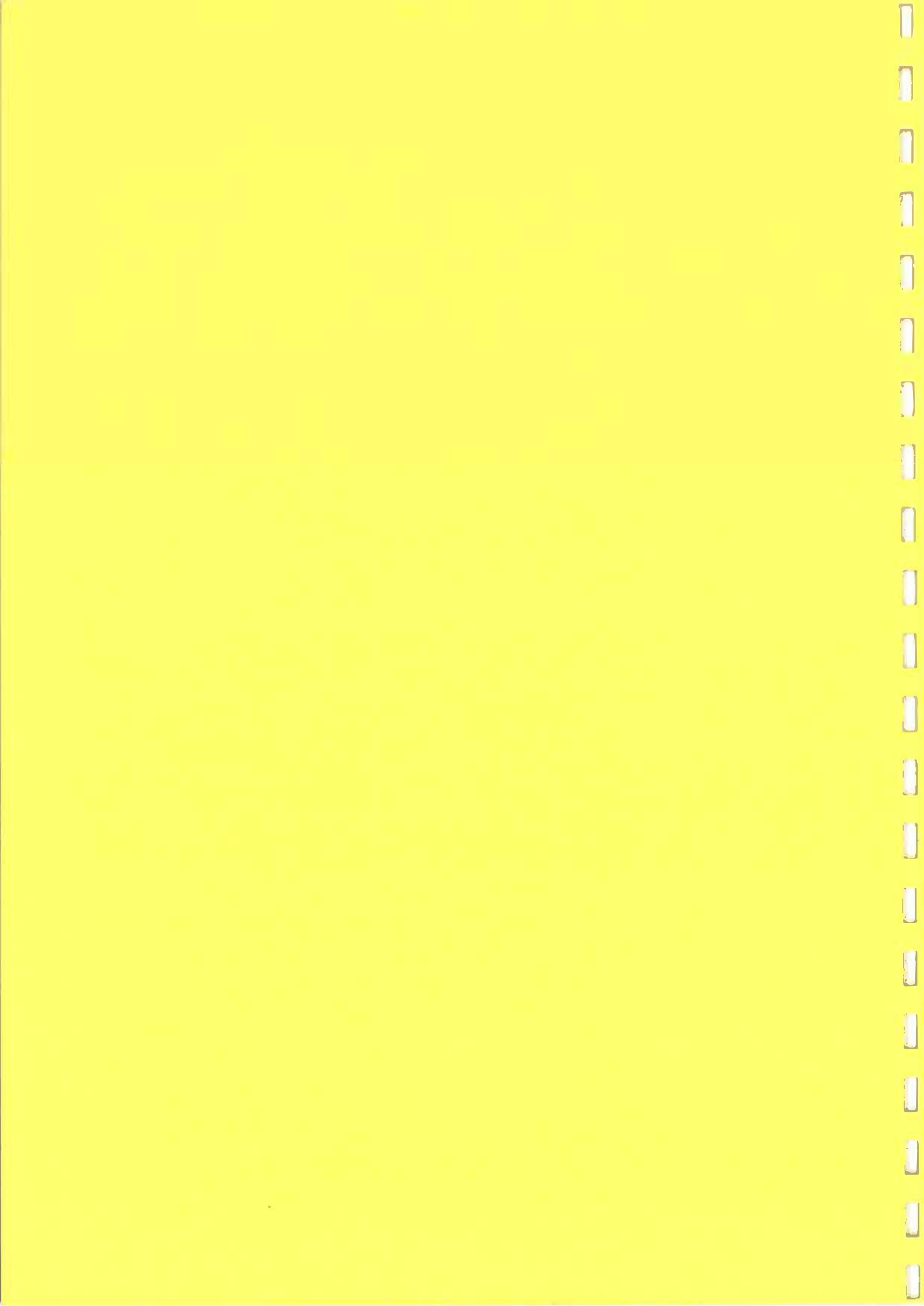

Specifications for cleaning of ventilation ducts



IRSST
Institut de recherche
en santé et en sécurité
du travail du Québec

CONTRACT : *Contract No.*

*Cleaning
of ventilation
ducts*

Section 15: _____

Page: _____

Date: _____

PART 1.0 – GENERAL:

- 1.1 Scope of work
- .1 The work consists of cleaning the air ducts in ventilation system *system no.* indicated on drawing *Reference no.*
 - .2 Cleaning of the following components: fan(s), louver(s), exhaust fan(s), deflector(s), damper(s), coil(s), terminal box(es), flexible duct(s), humidifier, drain pan(s), heat exchanger(s), diffuser(s), grill(s).
 - .3 The installation of access doors.
 - .4 The dismantling of ceilings and their reinstallation, protection of equipment, protection and moving of furniture, and the protection of floors, partitions and other finishes.
 - .5 The supply, placement and installation of all equipment for carrying out the work.
 - .6 The repair and replacement of damaged acoustic and thermal insulation.
- 1.2 Related work *Depending on the contract*
- 1.3 Reference standards
- .1 Mechanical Cleaning of Non-Porous Air Conveyance Components (NADCA 01).
 - .2 Cleaning Fibrous Glass Insulated Air Duct Systems (NAIMA).
 - .3 *Other standards.*
- 1.4 Cleaning program
- .1 The Contractor shall supply with his tender the cleaning procedure selected, the equipment, the list of cleaning products and their safety data sheets.

Specifications for cleaning of ventilation ducts



IRSST
Institut de recherche
en santé et en sécurité
du travail du Québec

CONTRACT : *Contract No.*

Cleaning of ventilation ducts

Section 15: _____

Page: _____

Date: _____

PART 2.0 – EQUIPMENT AND PRODUCTS

- | | | | |
|-----|--|----|--|
| 2.1 | Cleaning products | .1 | The cleaning products for fans, coils, dampers and other components must be approved by the person awarding the contract (<i>name of person in charge</i>). |
| 2.2 | Access doors | .1 | Access doors shall be airtight and of the same gauge as the duct. |
| | | .2 | Access doors shall be prefabricated and adjusted to make them airtight using a gasket approved by the person awarding the contract. Acceptable product: <i>name of product</i> . |
| 2.3 | Insulation repair and replacement products | .1 | Acoustic insulation shall be repaired using the following product: <i>name of product</i> . |
| | | .2 | Thermal insulation shall be repaired using the following product: <i>name of product</i> . The insulation shall be covered by canvas such as the existing one. |
| | | .3 | Acoustic insulation shall be replaced using the following product: <i>name of product</i> . |
| | | .4 | Thermal insulation shall be replaced using the following product: <i>name of product</i> . |

PART 3.0 – EXECUTION

- | | | | |
|-----|--------------------------|----|--|
| 3.1 | Protection of personnel | .1 | The Contractor shall supply suitable protective equipment for the workers. |
| | | .2 | The Contractor shall obtain a certificate of solidity before entering the ventilation ducts. |
| 3.2 | Protection of components | .1 | The Contractor shall ensure that all the mechanical and electrical equipment located near the work is protected. |

Specifications for cleaning of ventilation ducts



IRSST
Institut de recherche
en santé et en sécurité
du travail du Québec

CONTRACT : *Contract No.*

Cleaning of ventilation ducts

Section 15: _____

Page: _____

Date: _____

-
- .2 The Contractor shall refrain from placing, on the ductwork's thermal insulation, any objects, equipment, tools and materials that could damage it.
 - .3 The Contractor shall avoid entering ducts when they are insulated inside. Protect the insulation if they must be entered.
- 3.3 Access doors
- .1 Install access doors upstream and downstream from each bend or obstacle.
 - .2 Install access doors every six (6) metres or as needed.
- 3.4 Cleaning sequence
- .1 Cleaning shall take place from upstream to downstream in the air flow in the following sequence:
 - .1 Stop the system.
 - .2 Replace filters before starting the cleaning.
 - .3 Clean from the return grills to the mixing plenum.
 - .4 Clean from the fresh air intake to the coils.
 - .5 Clean the coils.
 - .6 Clean from the coils to the supply diffusers.
 - .7 Clean the peripheral units.
 - .8 Repair the insulation (thermal or acoustic) as the work progresses.
 - .9 Replace the filter as needed.
 - .10 Restart the system.

Specifications for cleaning of ventilation ducts



IRSST
Institut de recherche
en santé et en sécurité
du travail du Québec

CONTRACT : *Contract No.*

Cleaning of ventilation ducts

Section 15: _____

Page: _____

Date: _____

-
- 3.5 Cleaning methods
- .1 Ducts not insulated inside:
 - .1 Dry brushing, followed by cleaning with a vacuum equipped with "HEPA" filter.
 - .2 Loosening the dirt with compressed air using a nozzle, followed by cleaning with the vacuum equipped with "HEPA" filter.
 - .3 The use of products must be approved by the person awarding the contract.
 - .4 Do not apply sealant on the ducts.
 - .2 Ducts insulated inside.
 - .1 Dry brushing with soft brush followed by cleaning with vacuum equipped with "HEPA" filter.
 - .2 Do not wet the insulation.
 - .3 Do not use any soap, disinfectant or sealant on the insulation.
 - .3 Water drain pans.
 - .1 Empty and wash with a 5-6% sodium hypochlorite solution (bleach) at a concentration of 250 mL per 4 litres of water. Take into account the time needed to completely purge the vapors before starting the system.
- 3.6 Qualification
- .1 The work shall be carried out by qualified people. The Contractor shall supply a list of similar work already carried out by the people selected.
- 3.7 Calibration dampers
- .1 The Contractor shall mark the position of the dampers before cleaning and return them to the same position afterwards.

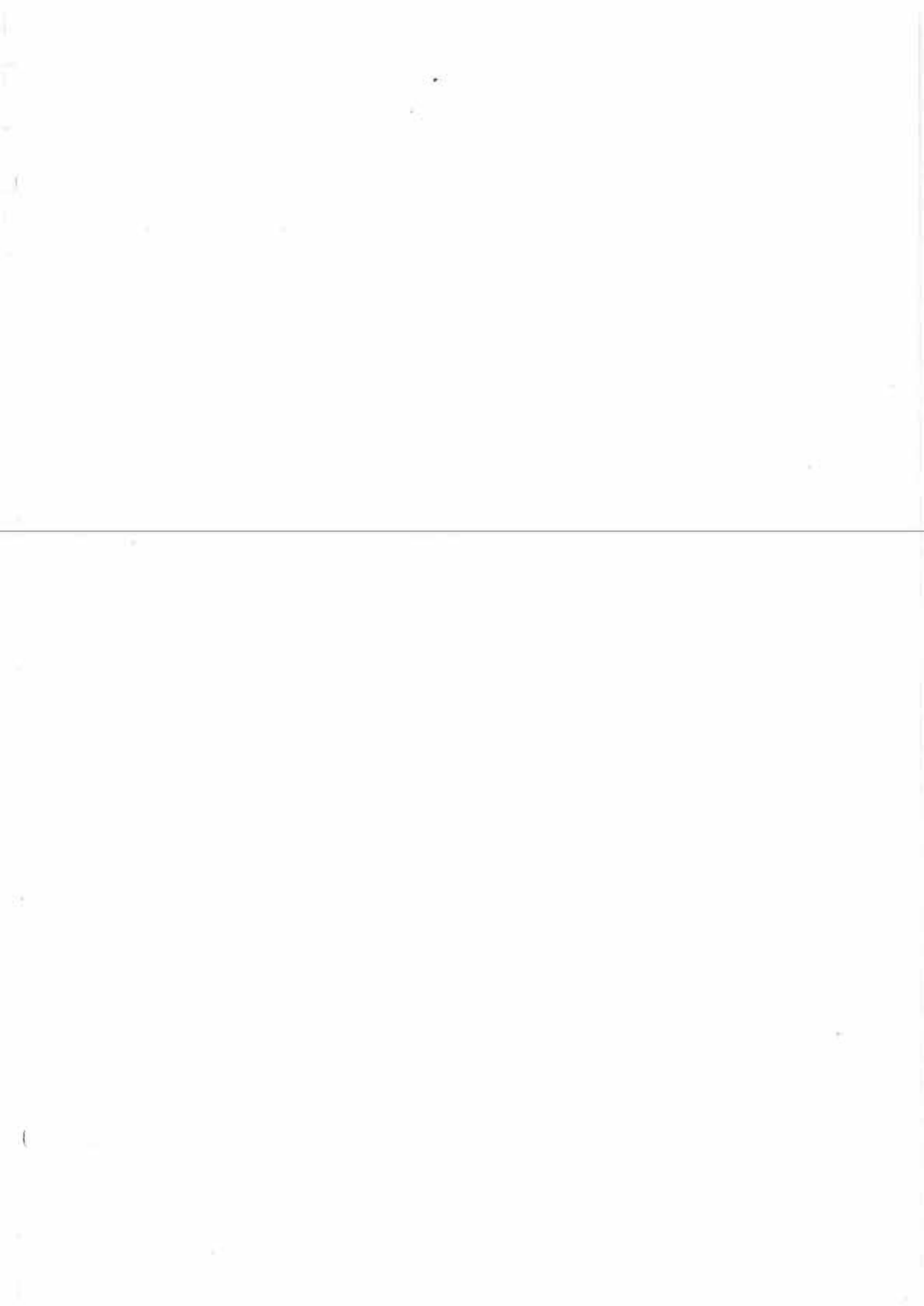



Inspection checklist

Evaluator: _____

Date: _____

COMPONENT	CONDITION 1 to 4	ACCESSI- BILITY	ACTION TO BE TAKEN
Outdoor air			
Outdoor air intakes			
Filters			
Heating coils			
Cooling coils			
Dehumidification coils			
Mixing plenums			
Humidifiers			
Condensation pans and drains			
Fans			
Sound attenuators			
Heat exchangers			
Supply ducts			
Return ducts			
Terminal boxes			
Diffusers			
Return grills			
Indoor environment			
Mechanical room			
Peripheral units			
Other (1)			
Other (2)			

Level of cleanliness: 1 = Very clean 2 = Thin layer of dust 3 = Dirty 4 = Reduction in flow

Signature : _____



Inspection checklist

Evaluator: _____

Date: _____

COMPONENT	CONDITION 1 to 4	ACCESSI- BILITY	ACTION TO BE TAKEN
Outdoor air			
Outdoor air intakes			
Filters			
Heating coils			
Cooling coils			
Dehumidification coils			
Mixing plenums			
Humidifiers			
Condensation pans and drains			
Fans			
Sound attenuators			
Heat exchangers			
Supply ducts			
Return ducts			
Terminal boxes			
Diffusers			
Return grills			
Indoor environment			
Mechanical room			
Peripheral units			
Other (1)			
Other (2)			

Level of cleanliness: 1 = Very clean 2 = Thin layer of dust 3 = Dirty 4 = Reduction in flow

Signature : _____



Inspection checklist

Evaluator: _____

Date: _____

COMPONENT	CONDITION 1 to 4	ACCESSI- BILITY	ACTION TO BE TAKEN
Outdoor air			
Outdoor air intakes			
Filters			
Heating coils			
Cooling coils			
Dehumidification coils			
Mixing plenums			
Humidifiers			
Condensation pans and drains			
Fans			
Sound attenuators			
Heat exchangers			
Supply ducts			
Return ducts			
Terminal boxes			
Diffusers			
Return grills			
Indoor environment			
Mechanical room			
Peripheral units			
Other (1)			
Other (2)			

Level of cleanliness: 1 = Very clean 2 = Thin layer of dust 3 = Dirty 4 = Reduction in flow

Signature : _____



Inspection checklist

Evaluator: _____

Date: _____

COMPONENT	CONDITION 1 to 4	ACCESSI- BILITY	ACTION TO BE TAKEN
Outdoor air			
Outdoor air intakes			
Filters			
Heating coils			
Cooling coils			
Dehumidification coils			
Mixing plenums			
Humidifiers			
Condensation pans and drains			
Fans			
Sound attenuators			
Heat exchangers			
Supply ducts			
Return ducts			
Terminal boxes			
Diffusers			
Return grills			
Indoor environment			
Mechanical room			
Peripheral units			
Other (1)			
Other (2)			

Level of cleanliness: 1 = Very clean 2 = Thin layer of dust 3 = Dirty 4 = Reduction in flow

Signature : _____



Inspection checklist

Evaluator: _____ Date: _____

COMPONENT	CONDITION 1 to 4	ACCESSI- BILITY	ACTION TO BE TAKEN
Outdoor air			
Outdoor air intakes			
Filters			
Heating coils			
Cooling coils			
Dehumidification coils			
Mixing plenums			
Humidifiers			
Condensation pans and drains			
Fans			
Sound attenuators			
Heat exchangers			
Supply ducts			
Return ducts			
Terminal boxes			
Diffusers			
Return grills			
Indoor environment			
Mechanical room			
Peripheral units			
Other (1)			
Other (2)			

Level of cleanliness: 1 = Very clean 2 = Thin layer of dust 3 = Dirty 4 = Reduction in flow

Signature : _____



Inspection checklist

Evaluator: _____

Date: _____

COMPONENT	CONDITION 1 to 4	ACCESSI- BILITY	ACTION TO BE TAKEN
Outdoor air			
Outdoor air intakes			
Filters			
Heating coils			
Cooling coils			
Dehumidification coils			
Mixing plenums			
Humidifiers			
Condensation pans and drains			
Fans			
Sound attenuators			
Heat exchangers			
Supply ducts			
Return ducts			
Terminal boxes			
Diffusers			
Return grills			
Indoor environment			
Mechanical room			
Peripheral units			
Other (1)			
Other (2)			

Level of cleanliness: 1 = Very clean 2 = Thin layer of dust 3 = Dirty 4 = Reduction in flow

Signature : _____



Inspection checklist

Evaluator: _____

Date: _____

COMPONENT	CONDITION 1 to 4	ACCESSI- BILITY	ACTION TO BE TAKEN
Outdoor air			
Outdoor air intakes			
Filters			
Heating coils			
Cooling coils			
Dehumidification coils			
Mixing plenums			
Humidifiers			
Condensation pans and drains			
Fans			
Sound attenuators			
Heat exchangers			
Supply ducts			
Return ducts			
Terminal boxes			
Diffusers			
Return grills			
Indoor environment			
Mechanical room			
Peripheral units			
Other (1)			
Other (2)			

Level of cleanliness: 1 = Very clean 2 = Thin layer of dust 3 = Dirty 4 = Reduction in flow

Signature : _____



Inspection checklist

Evaluator: _____

Date: _____

COMPONENT	CONDITION 1 to 4	ACCESSI- BILITY	ACTION TO BE TAKEN
Outdoor air			
Outdoor air intakes			
Filters			
Heating coils			
Cooling coils			
Dehumidification coils			
Mixing plenums			
Humidifiers			
Condensation pans and drains			
Fans			
Sound attenuators			
Heat exchangers			
Supply ducts			
Return ducts			
Terminal boxes			
Diffusers			
Return grills			
Indoor environment			
Mechanical room			
Peripheral units			
Other (1)			
Other (2)			

Level of cleanliness: 1 = Very clean 2 = Thin layer of dust 3 = Dirty 4 = Reduction in flow

Signature : _____



Inspection checklist

Evaluator: _____ Date: _____

COMPONENT	CONDITION 1 to 4	ACCESSI- BILITY	ACTION TO BE TAKEN
Outdoor air			
Outdoor air intakes			
Filters			
Heating coils			
Cooling coils			
Dehumidification coils			
Mixing plenums			
Humidifiers			
Condensation pans and drains			
Fans			
Sound attenuators			
Heat exchangers			
Supply ducts			
Return ducts			
Terminal boxes			
Diffusers			
Return grills			
Indoor environment			
Mechanical room			
Peripheral units			
Other (1)			
Other (2)			

Level of cleanliness: 1 = Very clean 2 = Thin layer of dust 3 = Dirty 4 = Reduction in flow

Signature : _____



Inspection checklist

Evaluator: _____

Date: _____

COMPONENT	CONDITION 1 to 4	ACCESSI- BILITY	ACTION TO BE TAKEN
Outdoor air			
Outdoor air intakes			
Filters			
Heating coils			
Cooling coils			
Dehumidification coils			
Mixing plenums			
Humidifiers			
Condensation pans and drains			
Fans			
Sound attenuators			
Heat exchangers			
Supply ducts			
Return ducts			
Terminal boxes			
Diffusers			
Return grills			
Indoor environment			
Mechanical room			
Peripheral units			
Other (1)			
Other (2)			

Level of cleanliness: 1 = Very clean 2 = Thin layer of dust 3 = Dirty 4 = Reduction in flow

Signature : _____

