

#8692

**REPORT**

**EASE Demonstration Project  
APCHQ's Advanced House**

Presented to:

**Jacques Rousseau**  
Project Manager  
and  
**Pierre-Michel Busque**  
Project Officer

**Canada Mortgage and Housing Division**  
Housing Innovation Division  
700 Montreal Road  
Ottawa, Ontario  
K1A 0P7

From:

**Morrison Hershfield Limited**

Report No. 33121.04  
331204-0611 Repl.doc

January 4<sup>th</sup>, 1995



## **DISCLAIMER**

This study was conducted for Canada Mortgage and Housing Corporation under Part IX of the National Housing Act. The analysis, interpretation and recommendations are those of the consultants and do not necessarily reflect the views of Canada Mortgage and Housing Corporation or those divisions of the Corporation that assisted in the study and its publication.



## **CMHC MANDATE**

Canada Mortgage and Housing Corporation, the Federal Government's housing agency, is responsible for administering the National Housing Act.

This legislation is designed to aid in the improvement of housing and living conditions in Canada. As a result, the Corporation has interests in all aspects of housing and urban growth and development.

Under Part IX of this Act, the Government of Canada provides funds to CMHC to conduct research into the social, economic and technical aspects of housing and related fields, and to undertake the publishing and distribution of the results of this research. CMHC therefore has a statutory responsibility to make available, information which may be useful in the improvement of housing and living conditions.

This publication is one of the many items of information published by CMHC with the assistance of federal funds.



## EXECUTIVE SUMMARY

The EASE Air Barrier System consists of a sheet of Tyvek sandwiched between two layers of fiberboard on the exterior side of the insulation.

This system was used in APCHQ's entrant to the Advanced House Program. As part of the monitoring program on this house, long term measurements of pressures, temperatures and relative humidities across the various layers of the wall systems were recorded. Morrison Hershfield was engaged to develop the house's air barrier construction details, analyze the monitoring data and draw conclusions on the performance of the EASE air barrier system.

The monitoring data indicated that the temperature within the insulated cavity always remained above the dewpoint temperature of the air in the cavity. Data extrapolated to estimate temperature at the EASE air barrier itself indicated that there may have been occasions of condensation occurring at this exterior surface in certain weather conditions. Since this did not affect moisture levels further in the cavity, we can assume that this did not create a problem and probably diffused through the vapor permeable EASE Air Barrier System.

In both monitored wall sections, one with brick cladding and one with stucco cladding, pressure monitoring found that pressure loads across the air barrier membrane were quite small. The peak pressure recorded across the wall system was in the order of 275 Pa. The majority of the pressure across the wall system as a whole was carried by the exterior cladding materials. Since airtightness testing showed that the wall system was relatively airtight, it was concluded that the lack of compartmentalization in the cavity between cladding and air barrier system limited pressure equalization across the cladding. This sheltered the air barrier membrane from both peak and average pressures.





## RÉSUMÉ

Le pare-air extérieur est constitué par une membrane Tyvek intercalée entre deux couches de panneau de fibres, du côté extérieur de l'isolant.

Ce pare-air a été proposé par l'APCHQ aux termes du Programme de la maison performante. Dans le cadre du contrôle de cette maison, on a prélevé sur une longue période la pression, la température et le degré d'humidité relative de différentes couches des systèmes muraux. Les services de Morrison Hershfield ont été retenus pour mettre au point la technique d'exécution du pare-air de la maison, analyser les données de contrôle et tirer des conclusions quant à la performance du pare-air extérieur.

Les données de contrôle indiquent que la température à l'intérieur de la cavité isolée demeure toujours au-dessus de la température du point de rosée de l'air s'y trouvant. Les données extrapolées en vue d'estimer la température à l'endroit du pare-air extérieur proprement dit indiquent qu'il se pourrait qu'il se forme de la condensation sur cette face extérieure dans certaines conditions climatiques. Puisque cela n'a pas davantage influé sur le degré d'humidité dans la cavité, nous pouvons présumer que la présence de condensation n'a pas occasionné de problème et qu'elle s'est probablement diffusée à travers le pare-air extérieur, perméable à la vapeur.

Dans les deux sections murales contrôlées, l'une présentant un placage de brique et l'autre un parement de stucco, le contrôle de la pression a permis de découvrir que le pare-air ne subissait que d'assez faibles charges. La pression de pointe enregistrée sur le système mural était de l'ordre de 275 Pa. La majorité de la pression enregistrée sur l'ensemble du système mural était portée par le parement extérieur. Étant donné que les essais d'étanchéité à l'air révèlent que le système mural était relativement étanche à l'air, on a conclu que le manque de compartimentation dans la cavité formée entre le parement et le pare-air limitait l'équilibrage de la pression sur le parement. Cette situation mettait le pare-air à l'abri à la fois des pressions de pointe et des pressions moyennes.



# CMHC SCHL

Helping to  
house Canadians

Question habitation,  
comptez sur nous

National Office

Bureau national

700 Montreal Road  
Ottawa, Ontario  
K1A 0P7

700 chemin de Montréal  
Ottawa (Ontario)  
K1A 0P7

Puisqu'on prévoit une demande restreinte pour ce document de recherche, seul le sommaire a été traduit.

La SCHL fera traduire le document si la demande le justifie.

Pour nous aider à déterminer si la demande justifie que ce rapport soit traduit en français, veuillez remplir la partie ci-dessous et la retourner à l'adresse suivante :

Le Centre canadien de documentation sur l'habitation  
La Société canadienne d'hypothèques et de logement  
700, chemin de Montréal, bureau C1-200  
Ottawa (Ontario)  
K1A 0P7

**TITRE DU RAPPORT :** \_\_\_\_\_  
\_\_\_\_\_

Je préférerais que ce rapport soit disponible en français.

**NOM** \_\_\_\_\_

**ADRESSE** \_\_\_\_\_  
rue app.

\_\_\_\_\_ ville province code postal

**No de téléphone** ( ) \_\_\_\_\_

TEL: (613) 748-2000

Canada Mortgage and Housing Corporation

Société canadienne d'hypothèques et de logement

Canada





## TABLE OF CONTENTS

	<b>Page</b>
<b>1. INTRODUCTION</b>	<b>1</b>
<b>2. METHODOLOGY</b>	<b>2</b>
<b>3. FINDINGS</b>	<b>3</b>
3.1 Base Data Provided	3
3.2 Data Integrity	3
3.3 Observations	4
<b>4. DISCUSSION AND CONCLUSIONS</b>	<b>15</b>

**Appendix A: Monitored Locations and Data Channels**

**Appendix B: Monitoring Data**

**Appendix C: Construction Details**

**Appendix D: Evaluation of Data by Others**

**Airtightness**

**HOT-2000 Simulation**

**EMPTIED Simulation**



## 1. INTRODUCTION

Canada Mortgage and Housing supported the design, construction and performance evaluation of the APCHQ's entry into the Advanced House Program. This house employed a number of innovative features including an air barrier system known as the External Air Systems Elements (EASE) system. With this system the air barrier of the wall system is made up of a water vapour permeable membrane (TYVEK™) sandwiched, for structural support, between two layers of fibre board. Some construction details are provided in Appendix C.

Part of the performance evaluation was long term monitoring of pressures, temperatures and humidity levels in and across the building envelope. Morrison Hershfield was retained to analyze the data supplied by CMHC and draw conclusions about the performance of the EASE system from this data.

Other evaluation procedures, including airtightness testing and simulations using HOT-2000 and EMPTIED, were carried out by others. The results are provided in Appendix D.

## 2. METHODOLOGY

The monitoring data analyzed for this report was supplied in electronic format by CMHC's monitoring contractor, TN Conseil. A description of monitoring station locations, data channels and schematic sketches of the instrument placements are provided in Appendix A. The monitoring system scanned the sensors at a frequency of approximately once every thirty seconds and processed and stored data based on a period of thirty minutes. The data stored for every thirty minute period was:

- mean value of all readings over the 30 minute period,
- the maximum single reading, minimum single reading and RMS value of pressure differential measurements over the 30 minute period.

At Morrison Hershfield, the data files were imported to Microsoft EXCEL spreadsheets for analysis. Manipulation of the data included converting relative humidity and temperature values to dew point temperature and estimating temperature of the EASE air barrier from measured temperatures in the wall cavity, outdoor temperature and the ratio of thermal resistance between the cavity temperature sensor and the air barrier and the sensor to outside. Plots of pressure difference, temperature and dew point data versus time were made for review. The records of maximum and minimum pressures were scanned to find high values which were then compared to the mean values in the respective data period.



### 3. FINDINGS

#### 3.1 Base Data Provided

Graphical output of the data provided are included in Appendix B. This output takes the form of monthly time based graphs for the:

##### North stucco wall

- pressure differences across the interior surface, between indoors and the air space outside the EASE air barrier, and the pressure difference between the indoors and outside.
- temperature and dew point temperature in the insulated cavity.

##### Southwest brick veneer wall

- pressure differences across the interior surface, between indoor environment and the air space between the EASE air barrier and cladding, and the pressure difference between the indoor environment and outside.
- temperature and dew point temperature in the insulated cavity.

##### Attic

Mean pressure difference between inside and attic.

#### 3.2 Data Integrity

Differential pressure transducers are very susceptible to zero drift with time and the data from the EASE house indicates that this did occur. The most noticeable example is from the southwest wall where October data showed the mean pressure difference across the wall went up and down from a base of about 5 Pascals. In January, the base was closer to 20 Pascals and in March and April it was closer to 35 Pascals. We believe that this difference in the base rate was due to zero drift rather than actual pressures changes.

This does not negate the value of the data. One can still assess where pressures were carried by looking at the cyclic pressure variations (in other words, the variation around the base whether it is zero or not). Figure 3.1 shows this for one data set, the southwest wall for the period January 1<sup>st</sup> through January 3, 1994. On this graph we have adjusted the data by subtracting the average pressure over the period from each data point, effectively negating the zero drift but also any steady pressure such as average stack force or mechanically induced pressure.

There was one period where there is an indication of a sensor problem with the north wall. The sensor measuring pressure across the interior surface exhibited gradually increasing values (zero drift) until June 16, 1994, at which point the data suddenly went off scale. Two days later it appears that the problem was corrected and the data after this time was exactly as one would expect indicating that it had been recalibrated.

One has to use caution in reviewing data on the maximum and minimum pressures recorded over the 30 minute data storage periods. The values stored in these registers are the highest and lowest single reading of any scan in the 30 minute data storage period. The recorded peaks could be due to a wind gust or an anomalous sensor reading. We found several points that we believe were the latter. These will be discussed in the appropriate place below.

### 3.3 Observations

1. In the monitoring period the mean pressure loads across the monitored walls were quite moderate, at least at the time base of the monitoring data. There were very few occasions where total pressure difference across the walls exceeded 150 Pascals and none exceeded 200.
2. There were two readings, both on the south west wall that had recorded peak pressures (a single reading in a 30 minute average period) across the wall of -500.0 Pa. These occurred in periods where mean pressure differences were low. We believe that these two data points are sensor reading anomalies and should be discarded. Ignoring these two points, the highest peak recorded pressure across the walls was 275 Pa. There were four storage periods where the recorded peak exceeded 200 Pa. The highest negative pressure recorded was -135 Pa.

APCHQ House - EASE Construction Details  
South-West Wall - Stucco Cladding  
Average Pressure Differences (adjusted) - February 1994

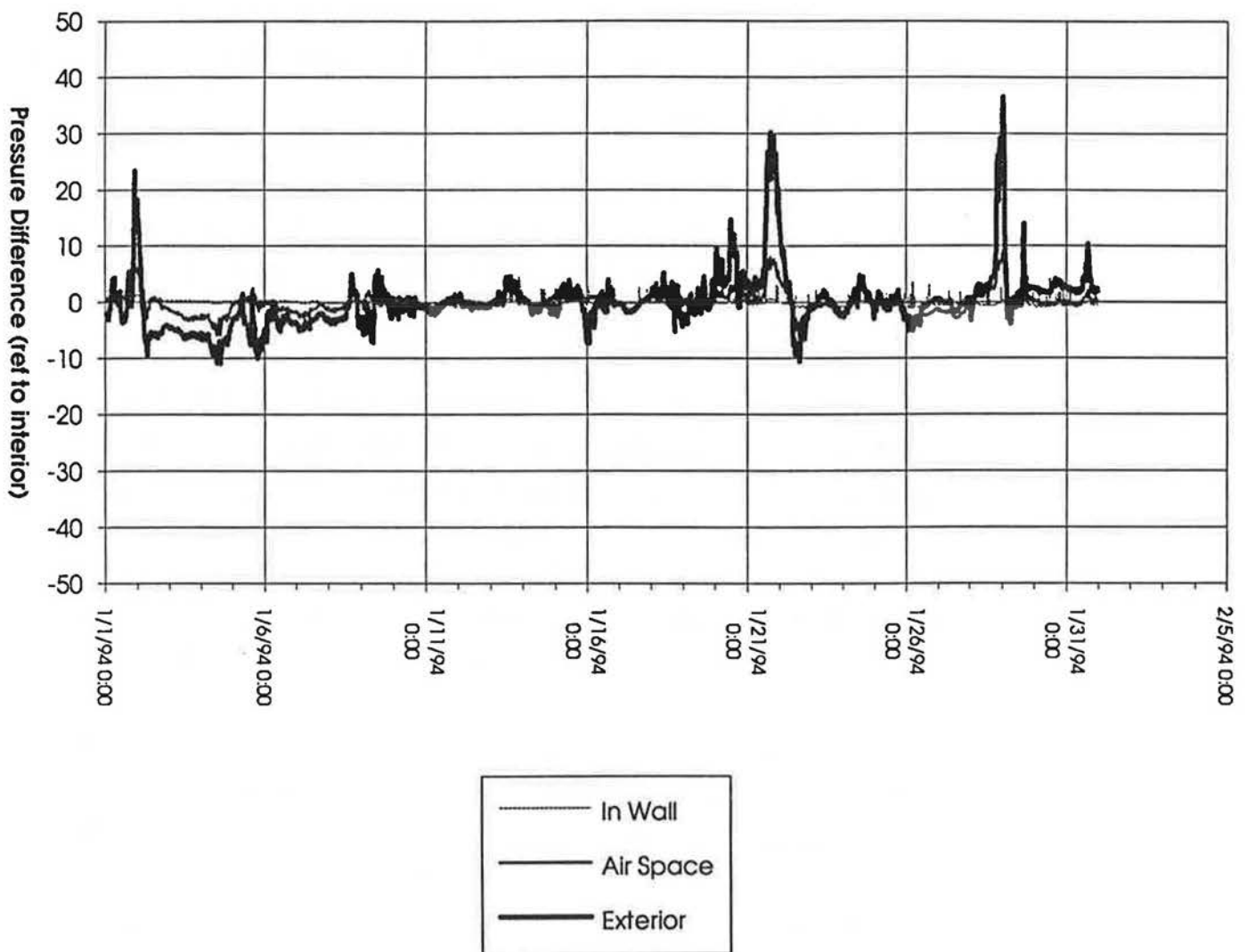

**Figure 3.1**  
Pressure Data Corrected for Average Pressure

3. By looking at the pressure variations around the base readings it is evident that the majority of the mean pressure differences across the walls is being carried by the exterior finishes (brick on southwest wall, stucco on the north wall) and not the EASE membrane. Virtually no pressure difference is being carried across the interior finishes.

This is shown graphically in Figures 3.2 and 3.3. One period of significant mean pressures across the wall was isolated for analysis. The percentage of the tested pressure carried by the cladding, EASE air barrier, and interior finish was determined (Figure 3.2) and plotted as a bar chart (Figure 3.3) for ten 30 minute recording periods.

4. A review of the recorded maximum and minimum pressures over the 30 minute data storage periods confirmed the above observations. In reviewing the data for the ten data storage periods in January and February with the highest recorded peak pressures, we found that the highest recorded peak pressure differences across the EASE membrane were +27 Pa and -53 Pa. In looking at the recorded maximum values (highest positive pressure outside to inside), the recorded maximum pressures across the EASE membrane were typically less than 15% of the recorded maximum pressures across the whole wall. The recorded minimum values (highest negative pressure outside to inside) showed that the recorded minimum pressures across the EASE membrane were typically about 50% of the recorded minimum pressures across the whole wall. We have no testable explanation for the difference between the two orientations.
5. Temperature and humidity data (the latter converted to dew point temperature) shows that in neither of the two monitored walls was there any occasion where the dew point temperature of the wall cavity approached the cavity temperature at the monitored location. Since this occurred in both cold and warm weather periods one would conclude that there has been no water collection in these cavities.

**APCHQ House - EASE Construction Details  
Pressure Distribution Across Wall System**

Date/Time	In-Wall Press Diff Corrected (Pa)	Air Space Press Diff Corrected (Pa)	Exterior Press Diff Corrected (Pa)	Across Interior Finish (%)	Across EASE (%)	Across Cladding (%)
1/21/94 17:00	0.7	8.0	30.2	2.5%	24.0%	73.5%
1/21/94 17:30	0.4	6.0	21.8	2.0%	25.4%	72.5%
1/21/94 18:00	0.4	6.8	26.3	1.7%	24.1%	74.2%
1/21/94 18:30	0.4	7.0	27.5	1.6%	23.8%	74.6%
1/21/94 19:00	0.4	7.0	28.6	1.6%	22.9%	75.5%
1/21/94 19:30	0.5	7.6	29.5	1.8%	23.9%	74.3%
1/21/94 20:00	0.4	6.6	25.1	1.8%	24.5%	73.7%
1/21/94 20:30	0.4	7.1	26.0	1.7%	25.6%	72.7%
1/21/94 21:00	0.4	6.9	26.4	1.7%	24.4%	73.9%
1/21/94 21:30	2.9	5.6	22.2	13.2%	12.0%	74.8%

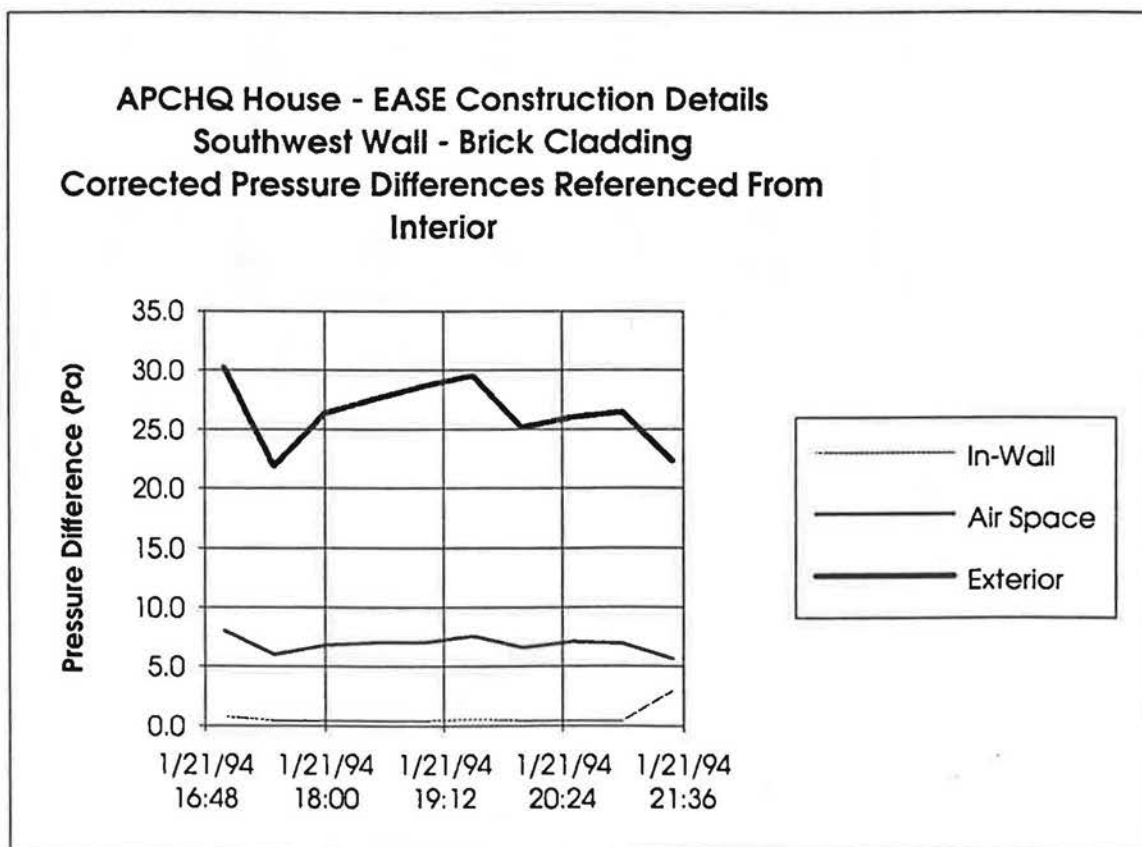

**Figure 3.2**

**APCHQ House - EASE Construction Details**  
**Southwest Wall - Brick Cladding**  
**Pressure Distribution Percentages Across Wall Assembly**

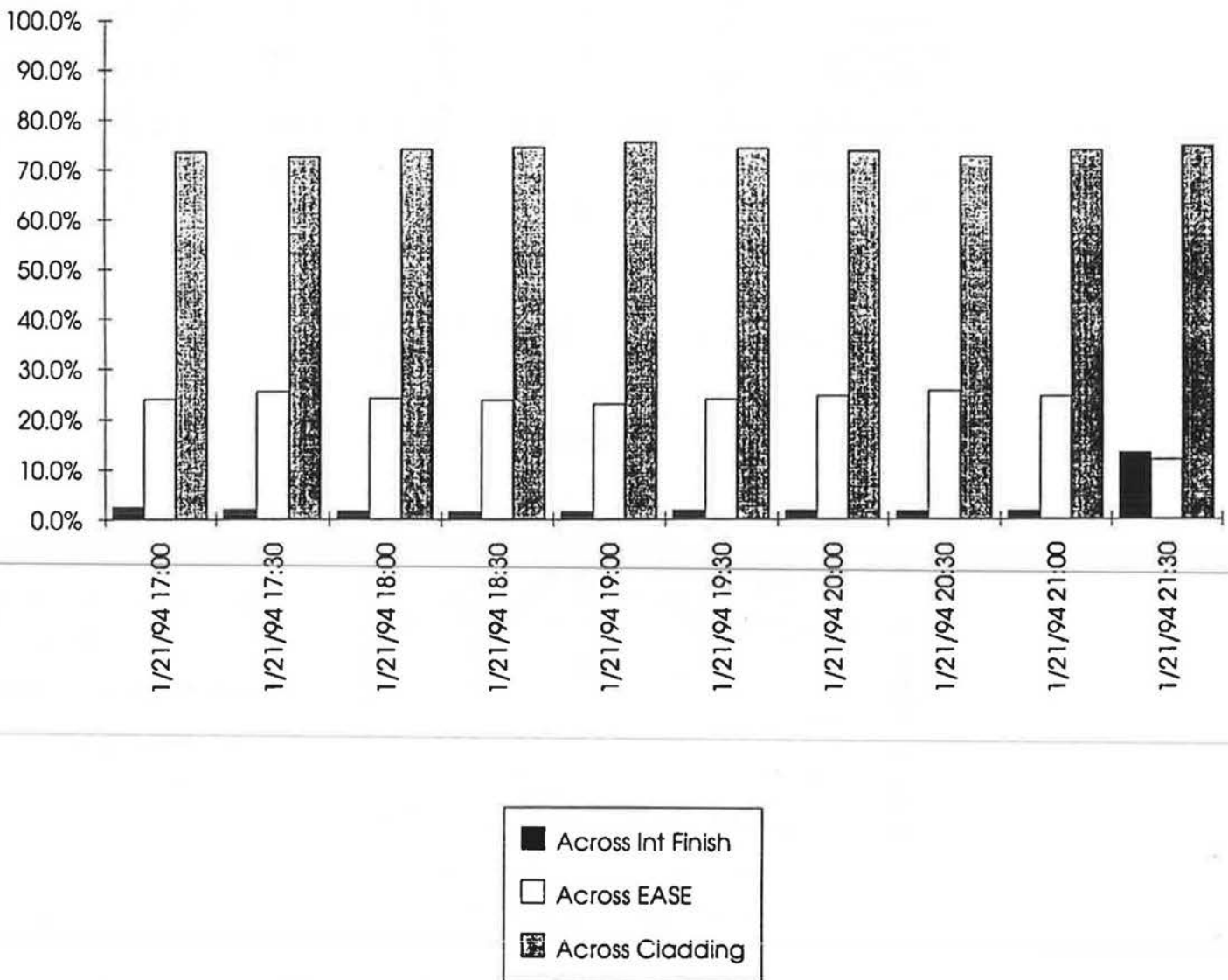

**Figure 3.3**

6. One question not directly answered by the monitoring results was “what were the hydrothermal conditions at the Tyvek of the Ease air barrier itself”. This question was addressed by calculating the temperature of the air barrier by the equation:

$$T_{\text{EASE}} = (T_{\text{sen}} - T_{\text{out}}) \times \frac{R_{\text{sen/EASE}}}{R_{\text{sen/out}}}$$

where

$T_{\text{EASE}}$  = is estimated temperature at EASE Air Barrier

$(T_{\text{sen}} - T_{\text{out}})$  is temperature difference between the sensor and outdoors

$R_{\text{sen/EASE}}$  is sum of thermal resistances from the sensor location to the EASE air barrier

$R_{\text{sen/out}}$  is the sum of thermal resistances from sensor location to outdoor air

This calculated temperature can be compared with the dewpoint temperature of air in the cavity.

Figures 3.4 and 3.5 show plots of the results for one week winter period for the north and south west walls respectively.

To minimize the confusion of thermal lags and solar effects only night (midnight to 6:00 A.M.) data is plotted. Figure 3.5 showed that the calculated temperature of the Tyvek at the southwest stucco wall generally remained above the calculated dewpoint temperature of the air inside the wall cavity. On the other hand Figure 3.4 shows that the calculated temperature of the Tyvek at the north brick wall vent below the cavity dewpoint temperature in three of the seven nights.

This, if true, would indicate that, at least sometimes, condensing conditions exist at the air barrier.

The importance of this analysis is questionable. No calibration information of the humidity sensors was available so the actual duration of a condensing condition is questionable and the moisture permeable EASE air barrier can accommodate some condensation.

7. A similar analysis to the above was carried out in summer conditions for a one week summer period. The plots are shown in Figures 3.6 and 3.7. These showed that the calculated cavity dewpoint temperature remaining below indoor temperatures indicating that condensation of the vapour barrier was not an issue. It is interesting to note that on the north wall the nighttime Tyvek temperature did approach the dewpoint temperature of cavity air.
8. It appears that the ceiling air barrier was sheltered from the peak values noted on the walls which were presumably caused by wind. The peak monitored pressure difference between inside and the attic was in the range of 15 Pascals.



APCHQ House - Ease Construction Details  
North Wall - Stucco Cladding  
In Wall/Exterior Temperature - January 1994

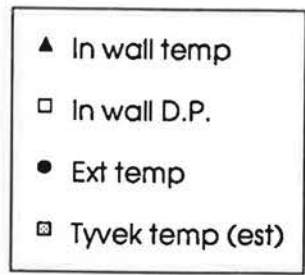
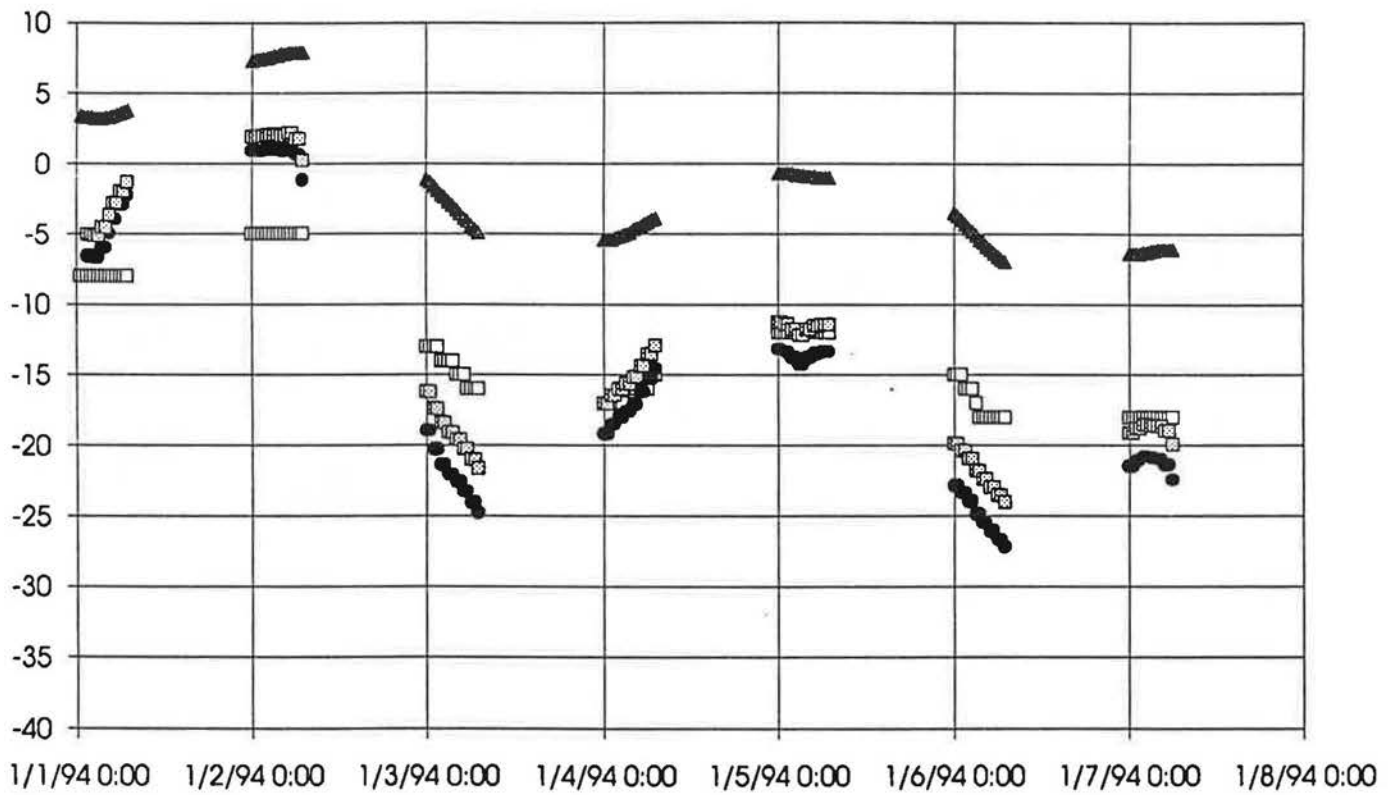
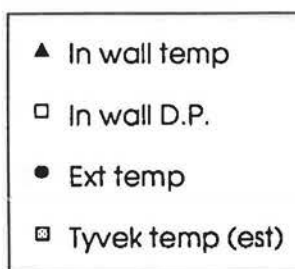
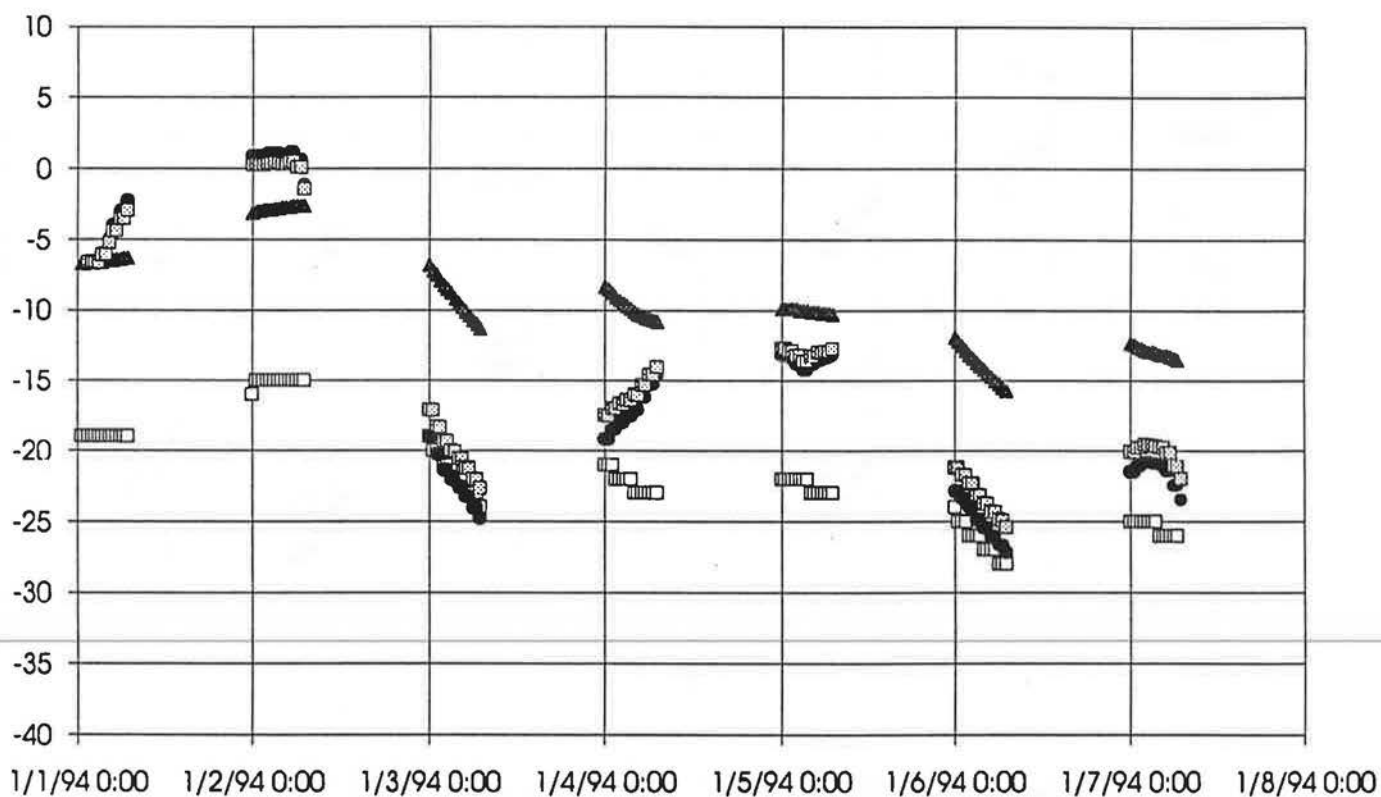

Figure 3.4

**APCHQ House - Ease Construction Details  
Southwest Wall - Brick Cladding  
In Wall/Exterior Temperature - January 1994**



**Figure 3.5**

APCHQ House - Ease Construction Details  
North Wall - Stucco Cladding  
In Wall/Exterior Temperature - June 1994

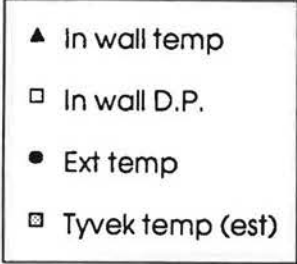
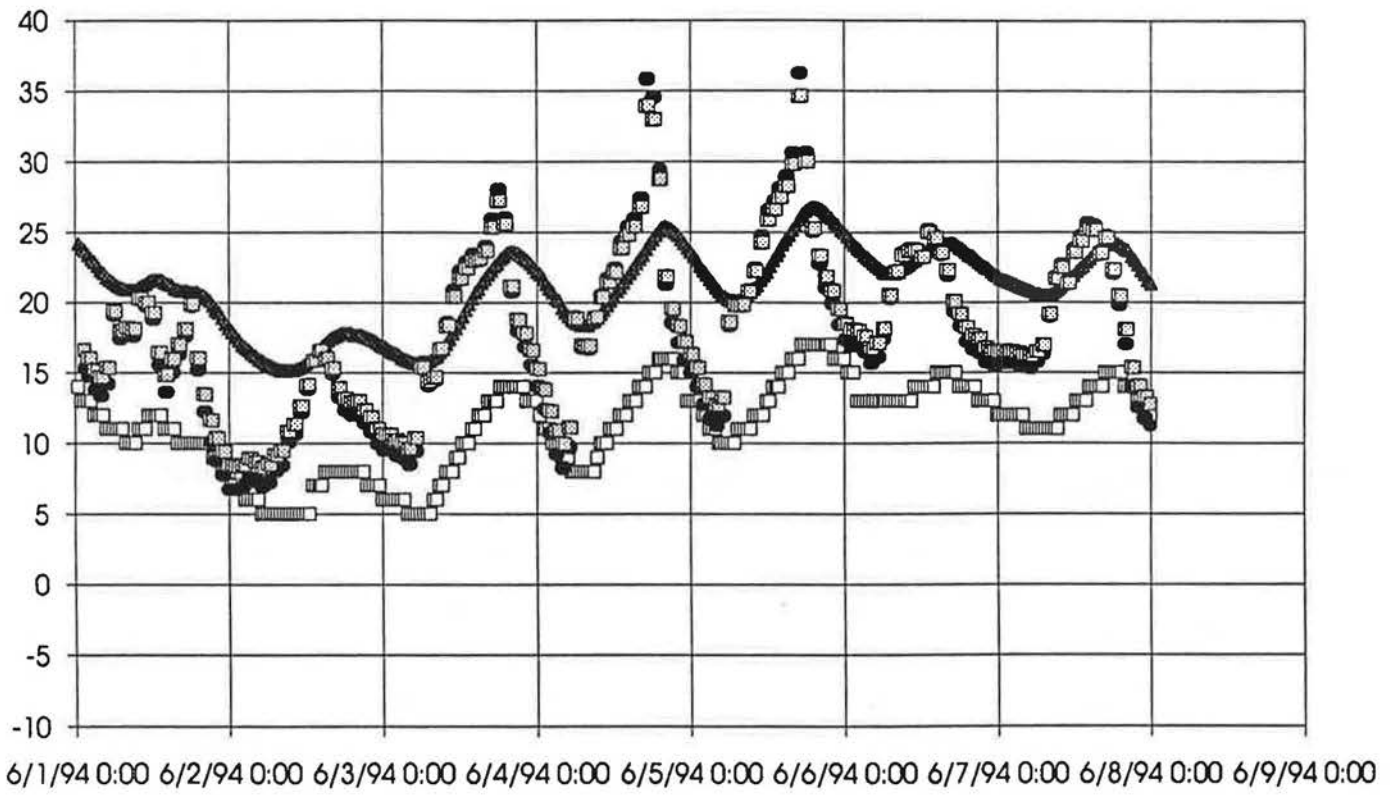

Figure 3.6

APCHQ House - Ease Construction Details  
Southwest Wall - Brick Cladding  
In Wall/exterior Temperature - June 1994

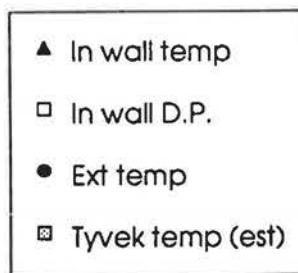
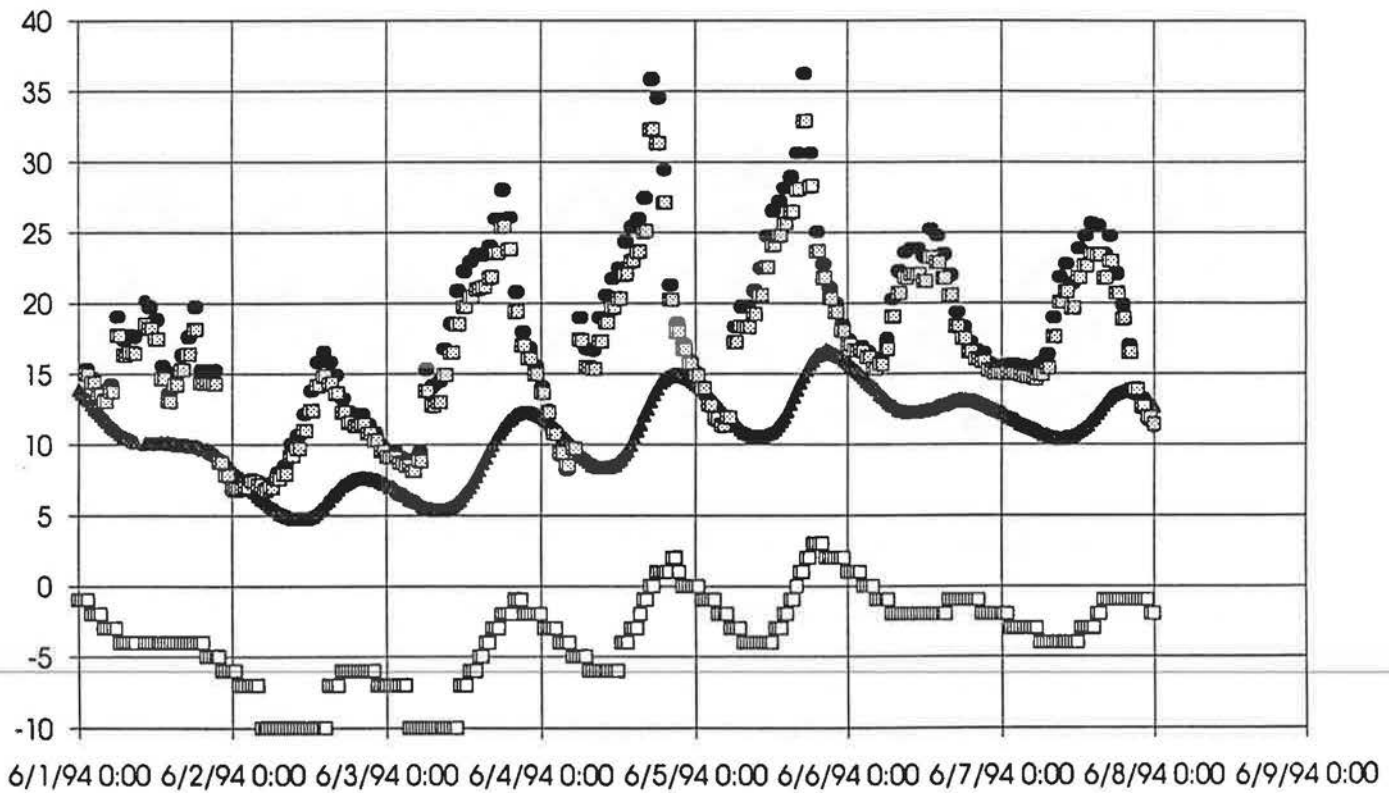

Figure 3.7

#### 4. DISCUSSION AND CONCLUSIONS

The supplied data indicates that the EASE air barrier system in the APCHQ house is performing the desired function of creating an external air barrier that did not allow moisture collection in the wall. While temperature analysis indicated that the Tyvek surface could go below dewpoint of the cavity air, there was no indication of moisture collection in the cavity and there was no pressure difference carried across the interior surface.

However, it does not appear that the pressure loads are being carried by the EASE membrane itself. Both the mean pressure data and recorded peak pressure data showed that the exterior cladding carried the bulk of the pressure across the wall.

We suspect that the reason for this relates to two factors: the relative stiffness of the EASE membrane compared to the exterior finishes and the degree of compartmentalization in the construction. The EASE membrane will be far less rigid than the exterior finishes used so that it would flex under pressure. This limits the potential for pressure equalization of the short-term dynamics caused by variations in wind pressure. We would also suspect the lack of compartmentalization is allowing lateral air flow in the air space between the finish and EASE membrane equalizing pressure in this air space and leaving the exterior finish to carry the pressure load.

This is not necessarily a failing of the system. Since fan depressurization testing indicates that this wall system is in fact relatively tight, (0.94 AC/hr @ 50 Pa) one can conclude that one has a well functioning drained and vented cavity wall system (but not a pressure equalized rainscreen) where the air barrier is shielded from the peak pressure differences. Mitigation of the pressures across the air barrier reduced the potential for damage to the air barrier elements and may increase their durability. The theoretical value of pressure equalization across the cladding is to reduce rain penetration into and across the cladding. In a wall system that tolerates and removes any water penetrating the cladding without ill effect, this advantage may be of minimal value.

An alternate scenario which would also account for the pattern of pressure distribution would suggest the EASE membrane is in fact much leakier than the exterior finishes. We don't believe this is true but our previous conjectures could be corroborated by measuring the pattern of pressure differences under a uniform pressure such as that created by a fan test.

We recommend that the pressure differences at the monitored sensor locations be measured when the building is subjected to a pressure difference created by a door fan. If the EASE air barrier membrane is still the most airtight surface and can carry the majority of this applied pressure, this would lend credence to our suggested pressure mitigation mechanisms.



---

Mark Lawton, P.Eng.  
Building Science Specialist



---

David L. Scott, B.Arch.  
Building Science Specialist

**MORRISON HERSHFIELD**

**APPENDIX A**  
**Data Channels**







BARDEAU D'ASPHALTE

STUC

BRIQUE

PLAN  
NE PAS UTILISER DANS LA CONSTRUCTION

DA

DESIGN ASSISTE  
PAR ORDINATEUR

**Les Dessins  
Drummond**

TOUTES LES COULEURS SONT EN OPTION  
TOUTE REPRODUCTION DE CE DOCUMENT PEUT ÊTRE FAITE SANS AUCUN DROIT DE VOTRE ENTREPRISE

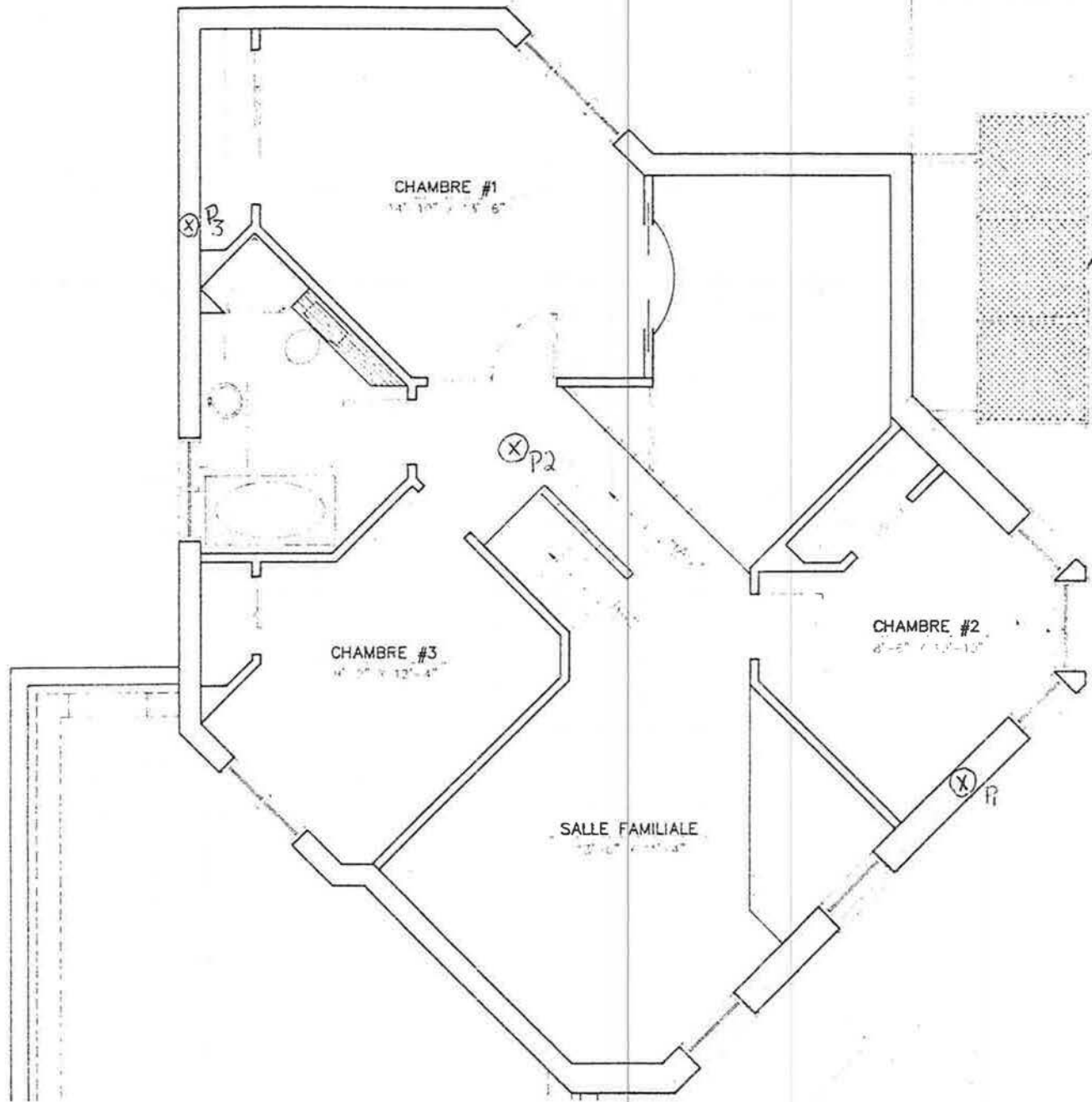

CHAMBRE #1  
14' 3" x 15' 6"

CHAMBRE #2  
8' 5" x 12' 10"

CHAMBRE #3  
14' 5" x 12' 4"

SALLE FAMILIALE  
12' 10" x 11' 4"

CARTON CLAPÉ



**DATA FORMAT FOR THE EASE MONITORING AT APCHQ HOUSE  
FILE \*.075, NORTH WALL**

```

75,93,10,02,16,00,00,0,0,0,0,0,0,0,0,0,0,0,0,0,0,0,0,0,0
75,93,10,02,16,30,00,0,0,0,0,0,0,0,0,0,0,0,0,0,0,0,0,0,0
75,93,10,02,17,00,00,42,22.9,52,16.3,1.8,1.4,2.4,1.8,0.6,-2.6,8.4,1.2,-2.2,4.9,2.8
75,93,10,02,17,30,00,42,22.8,52,16.3,1.8,1.4,2.4,1.8,0.8,-7.1,5.4,1.1,-2.2,1.9,2.6
75,93,10,02,18,00,00,42,22.7,52,16.3,1.9,1.4,1.9,1.9,0.8,-1.1,2.4,1,-2.4,-0.1,2.7
  
```

1 2 3 4 5 6 7 8 9 10 11 12 13 14 15 16 17 18 19 20 21 22

#	DESCRIPTION
1	save element #
2	year
3	month
4	day
5	hour
6	minute
7	second
8	mean room humidity (%)
9	mean room temperature (°C)
10	mean in-wall humidity (%)
11	mean in-wall temperature (°C)
12	mean in-wall delta-P (Pa)
13	min. in-wall delta-P (Pa)
14	max. in-wall delta-P (Pa)
15	RMS in-wall delta-P (Pa)
16	mean air space delta-P (Pa)
17	min. air space delta-P (Pa)
18	max. air space delta-P (Pa)
19	RMS air space delta-P (Pa)
20	mean outside delta-P (Pa)
21	max. outside delta-P (Pa)
22	RMS outside delta-P (Pa)

Note: All zero after data #7 indicates that no data were saved for this period.

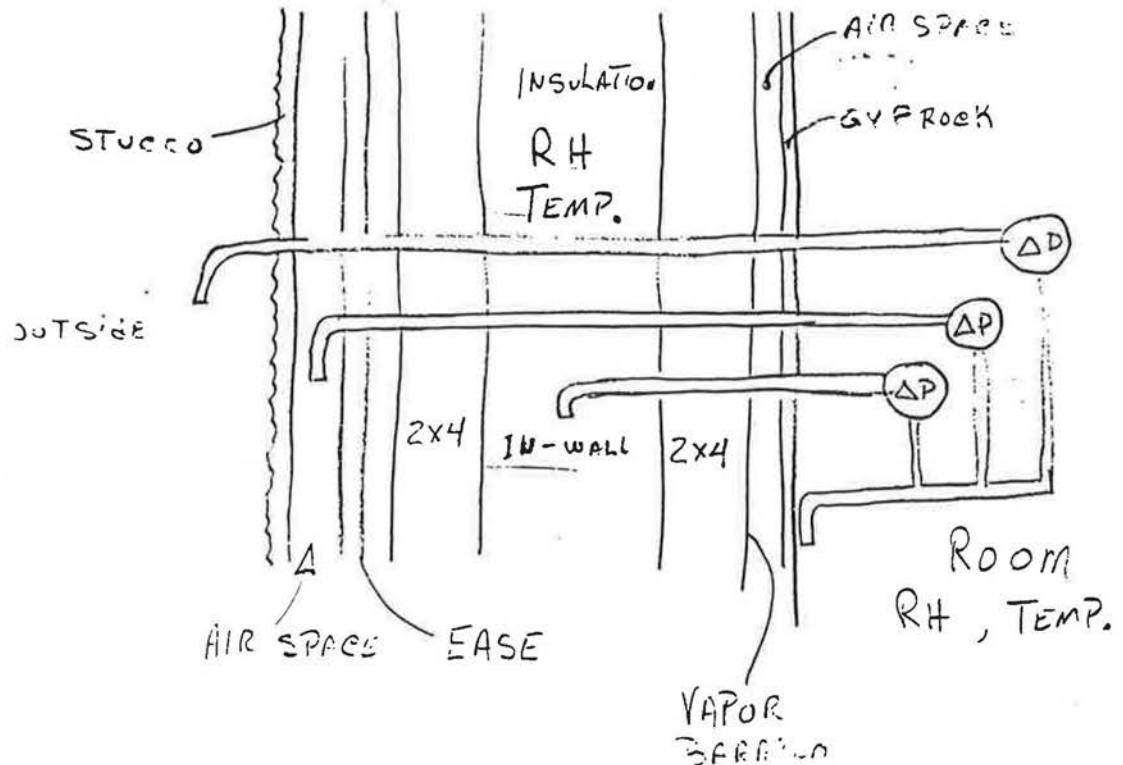

**DATA FORMAT FOR THE EASE MONITORING AT APCHQ HOUSE  
FILE \*.074, SOUTH-WEST WALL**

74,93,10,02,16,00,00,0,0,0,0,0,0,0,0,0,0,0,0,0,0,0,0,0  
 74,93,10,02,17,00,00,44,22.7,38,5.9,-1.8,-3.6,-0.6,1.9,-0.4,-11.1,3.9,1.6,8.9,24.4,9.6  
 74,93,10,02,17,30,00,43,22.6,38,5.9,-1.7,-2.6,-1.1,1.7,0.1,-6.1,3.4,0.9,11.1,30.9,11.3  
 74,93,10,02,18,00,00,43,22.5,38,5.9,-1.7,-2.1,-1.1,1.7,0.2,-2.6,3.4,0.9,11.7,30.9,11.8  
 74,93,10,02,18,30,00,43,22.4,38,5.9,-1.6,-2.1,-0.6,1.6,0.5,-2.1,5.4,1.2,12.5,35.4,12.2

1 2 3 4 5 6 7 8 9 10 11 12 13 14 15 16 17 18 19 20 21 22

#	DESCRIPTION
1	save element #
2	year
3	month
4	day
5	hour
6	minute
7	second
8	mean room humidity (%)
9	mean room temperature (°C)
10	mean in-wall humidity (%)
11	mean in-wall temperature (°C)
12	mean in-wall delta-P (Pa)
13	min. in-wall delta-P (Pa)
14	max. in-wall delta-P (Pa)
15	RMS in-wall delta-P (Pa)
16	mean air space delta-P (Pa)
17	min. air space delta-P (Pa)
18	max. air space delta-P (Pa)
19	RMS air space delta-P (Pa)
20	mean outside delta-P (Pa)
21	max. outside delta-P (Pa)
22	RMS outside delta-P (Pa)

Note: All zero after data #7 indicates that no data were saved for this period.

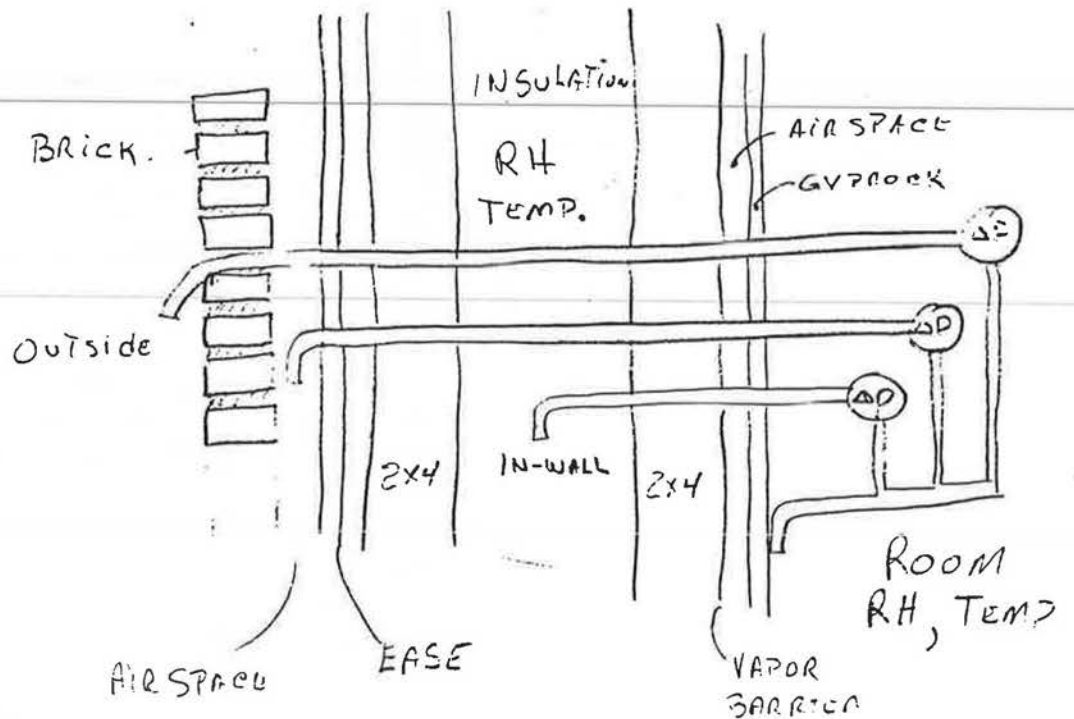

**DATA FORMAT FOR THE EASE MONITORING AT APCHQ HOUSE  
FILE \*.076, ATTIC**

```

76,93,10,02,16,30,00,0,0,0,0
76,93,10,02,17,00,00,-2,-13.1,2.9,2.4
76,93,10,02,17,30,00,-1.7,-8.6,2.4,1.8
76,93,10,02,18,00,00,-1.6,-3.6,0.9,1.7
76,93,10,02,18,30,00,-1.4,-3.6,1.4,1.6
  
```

1 2 3 4 5 6 7 8 9 10 11

#	DESCRIPTION
1	save element #
2	year
3	month
4	day
5	hour
6	minute
7	second
8	mean attic insulation delta-P (Pa)
9	min. attic insulation delta-P (Pa)
10	max. attic insulation delta-P (Pa)
11	RMS attic insulation delta-P (Pa)

Note: All zero after data #7 indicates that no data were saved for this period.

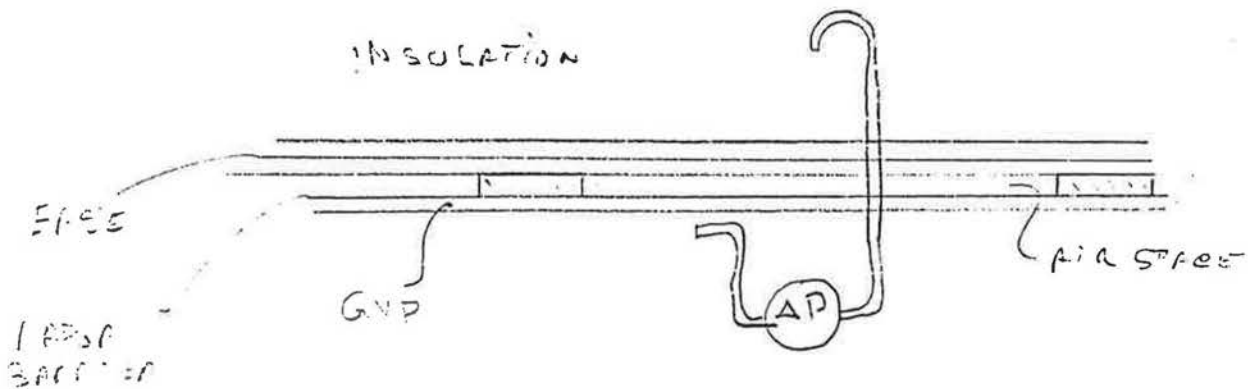



**APPENDIX B**  
**Data**





**APCHQ House - EASE Construction Details  
North Wall - Stucco Cladding  
Average Pressure Differences - October 1993**

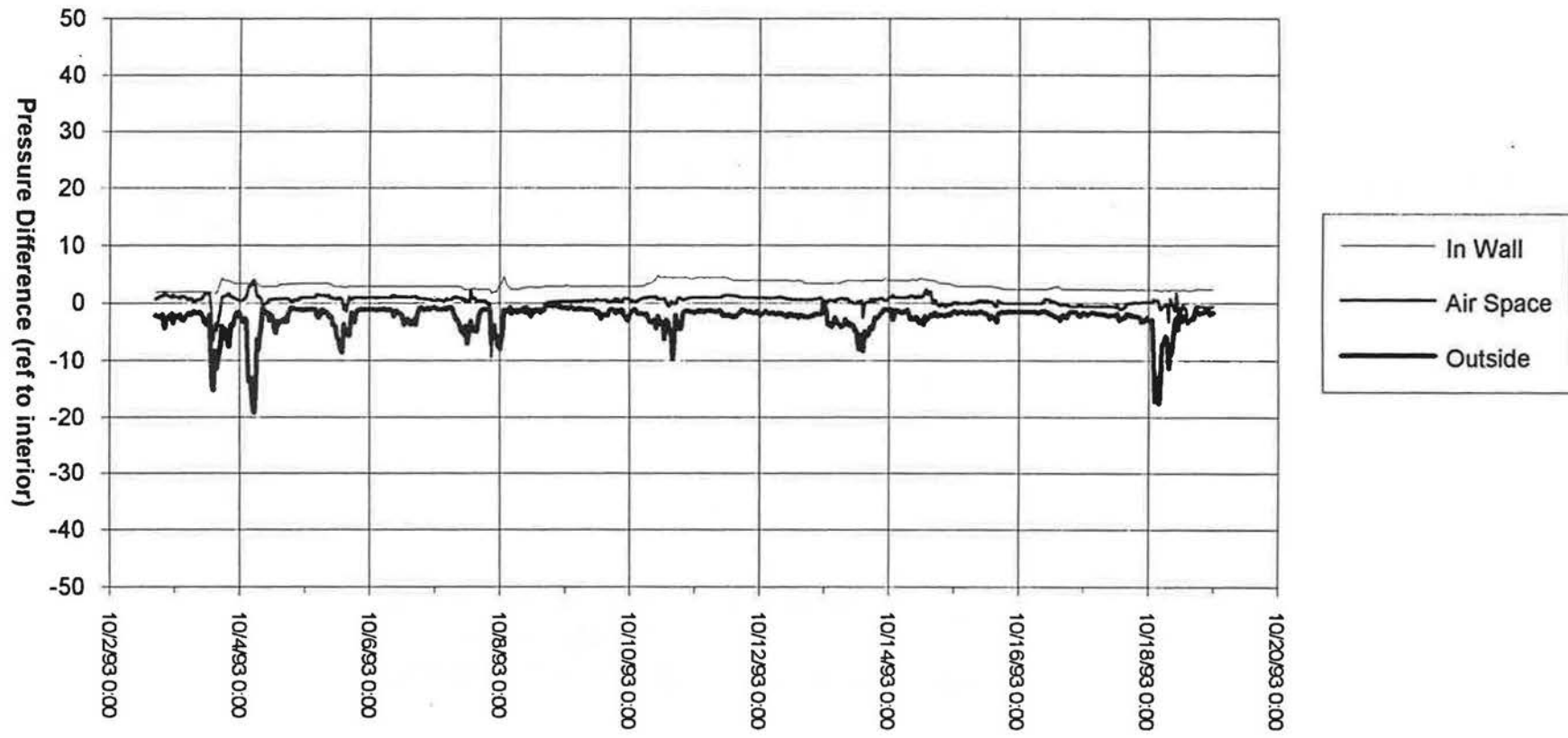

**APCHQ House - EASE Construction Details  
North Wall - Stucco Cladding  
Mean Pressure Differences - January 1994**

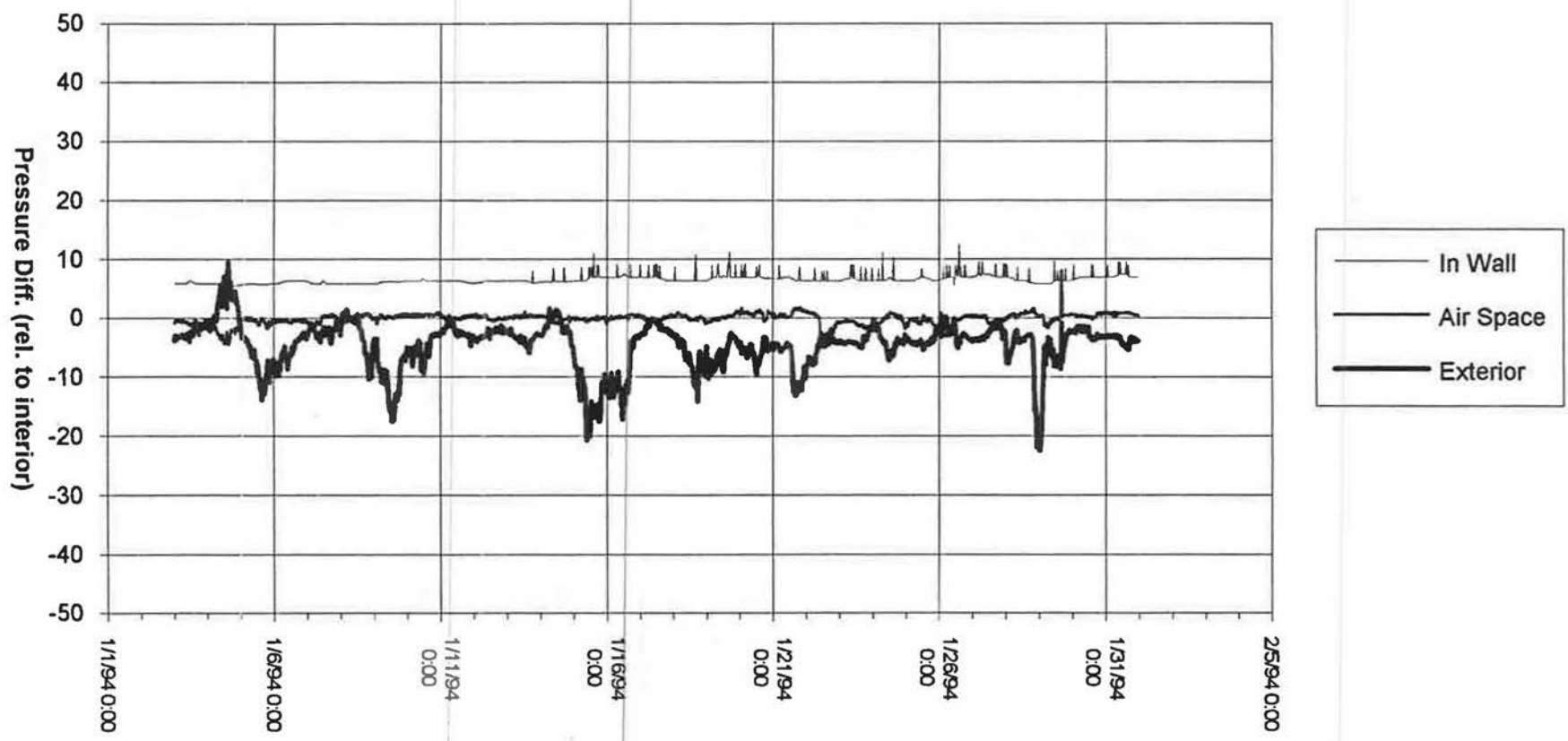

**APCHQ House - EASE Construction Details  
North Wall - Stucco Cladding  
Mean Pressure Differences - February 1994**

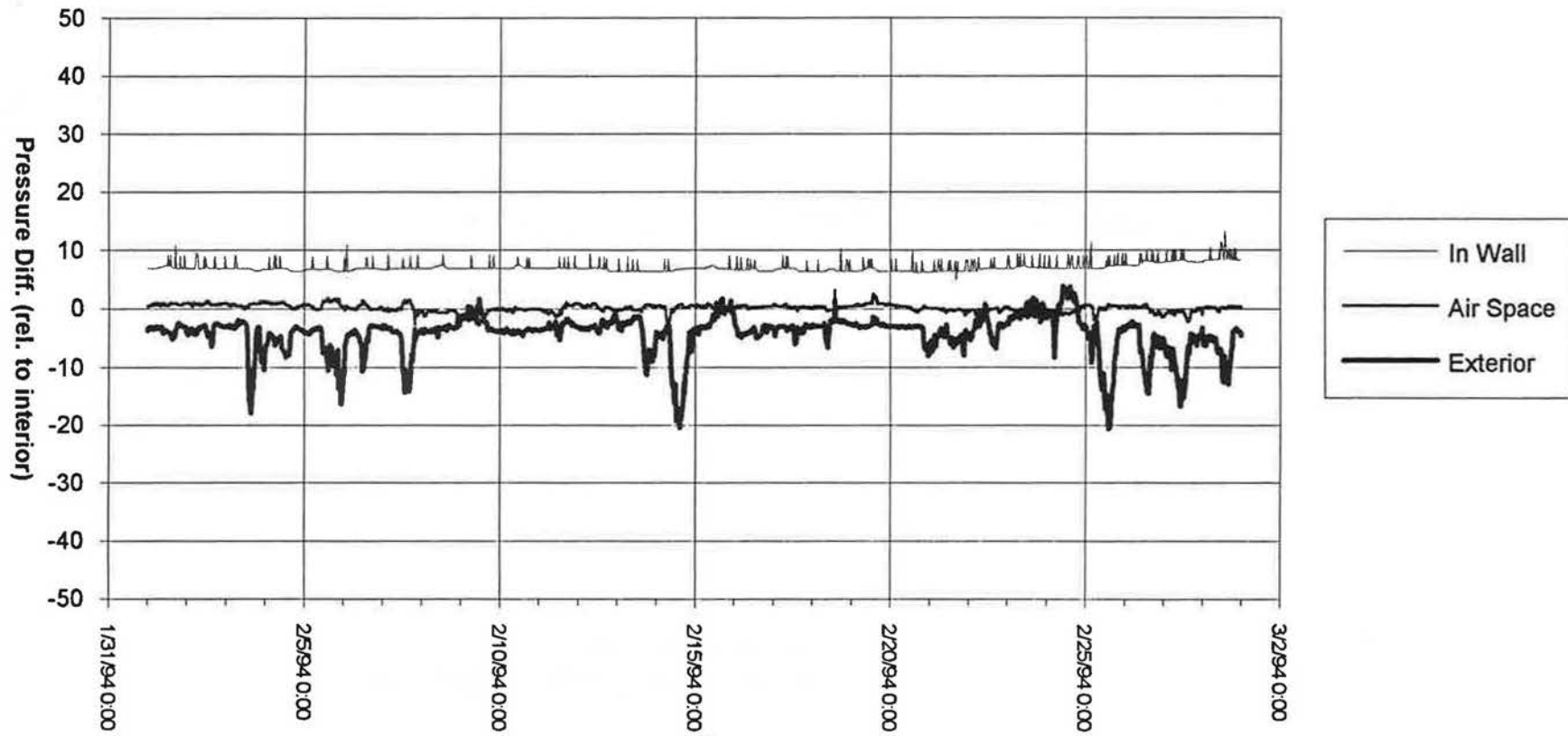

APCHQ House - EASE Construction Details  
North Wall - Stucco Cladding  
Mean Pressure Differences - March 1994

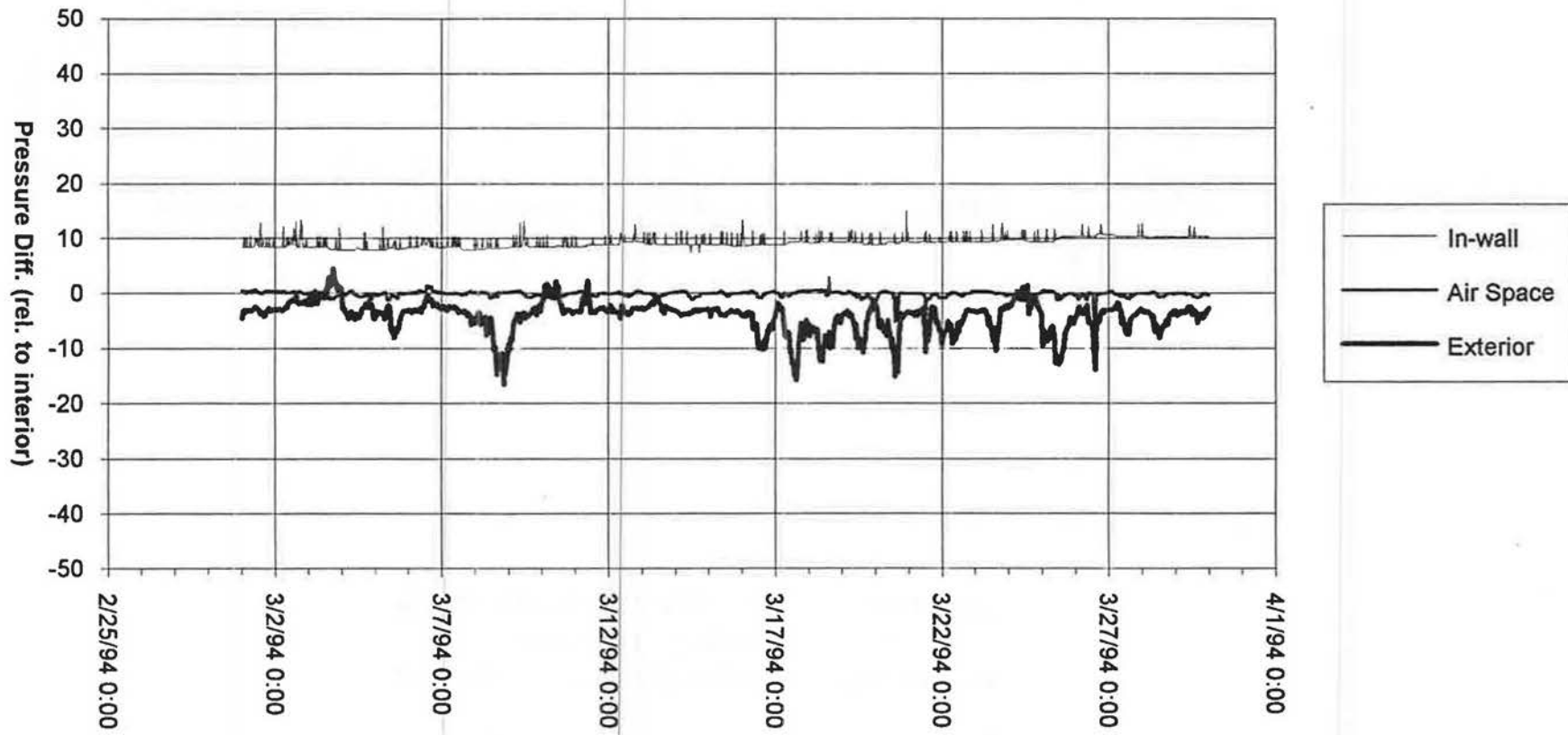

APCHQ House - EASE Construction Details  
North Wall - Stucco Cladding  
Mean Pressure Differences - April 1994

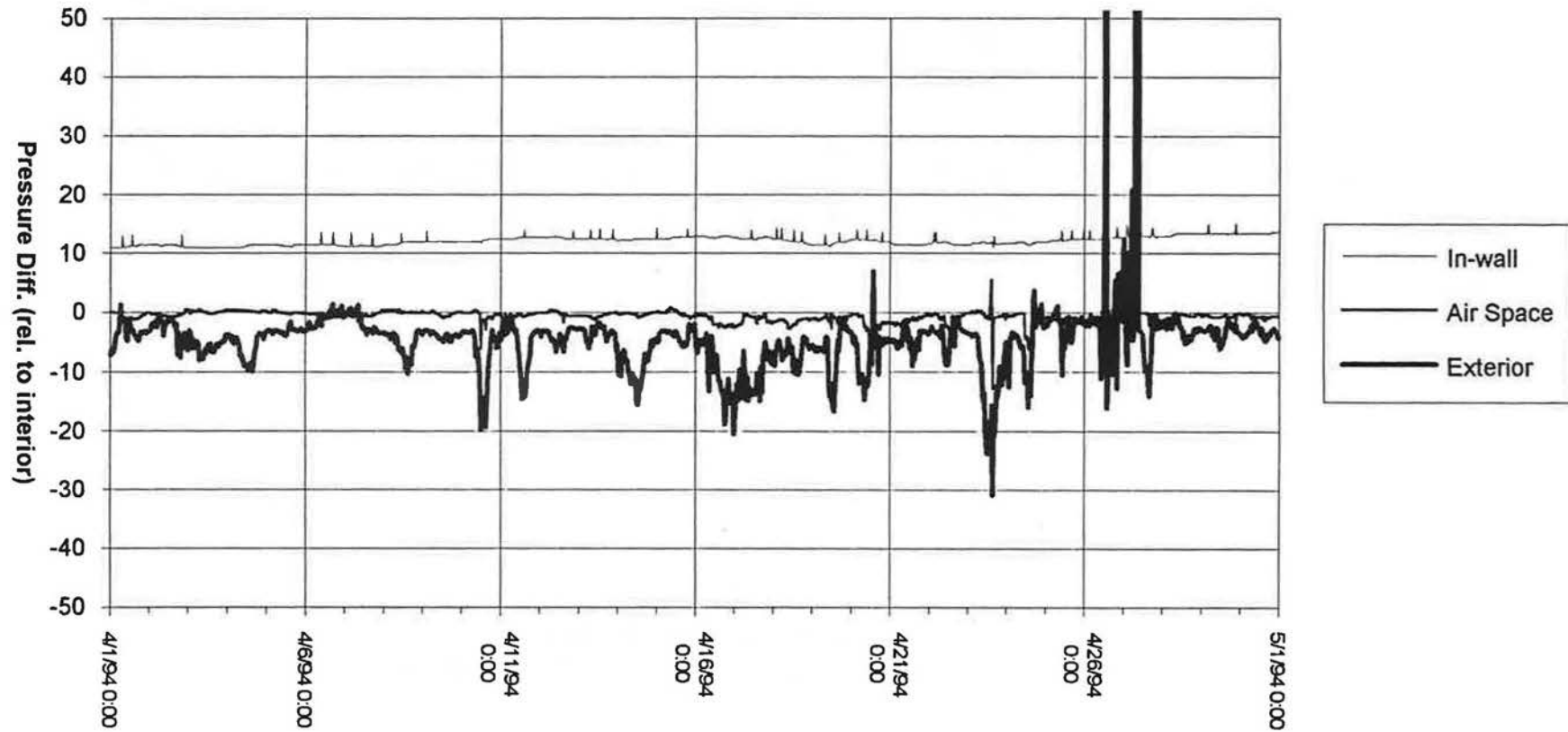

APCHQ House - EASE Construction Details  
North Wall - Stucco Cladding  
Mean Pressure Differences - May 1994

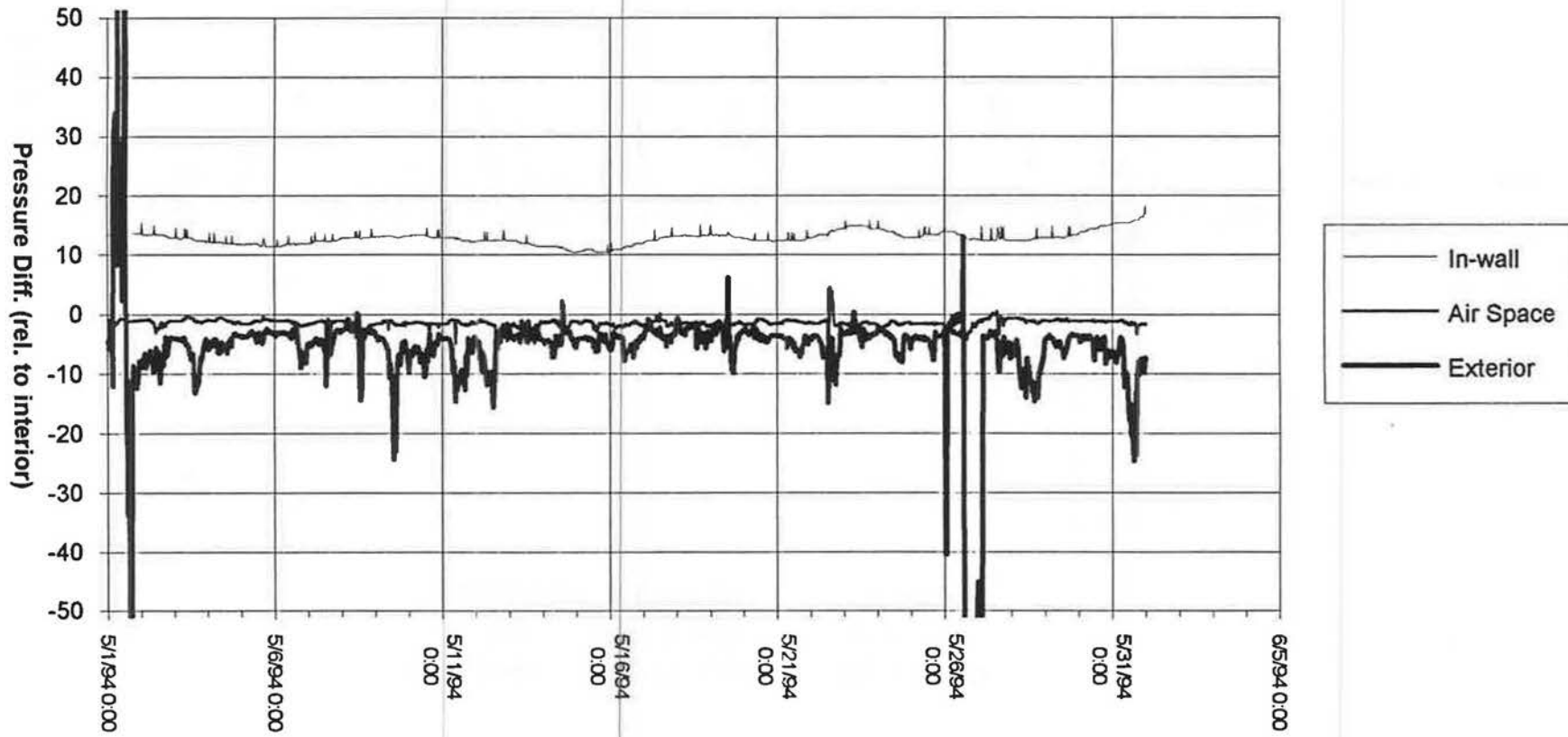

APCHQ House - EASE Construction Details  
North Wall - Stucco Cladding  
Mean Pressure Differences - June 1994

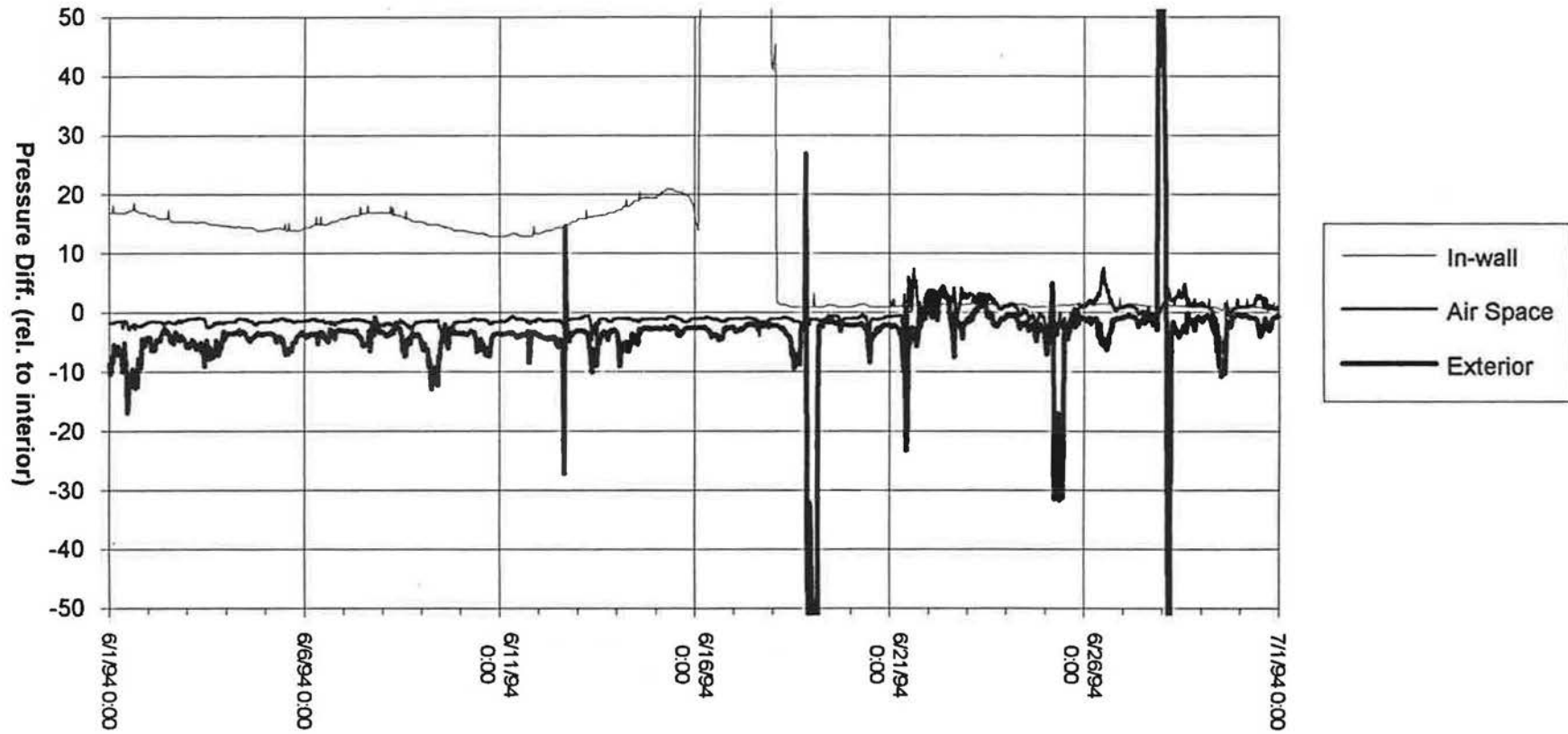

**APCHQ House - EASE Construction Details  
North Wall - Stucco Cladding  
Average Pressure Differences - October 1993**

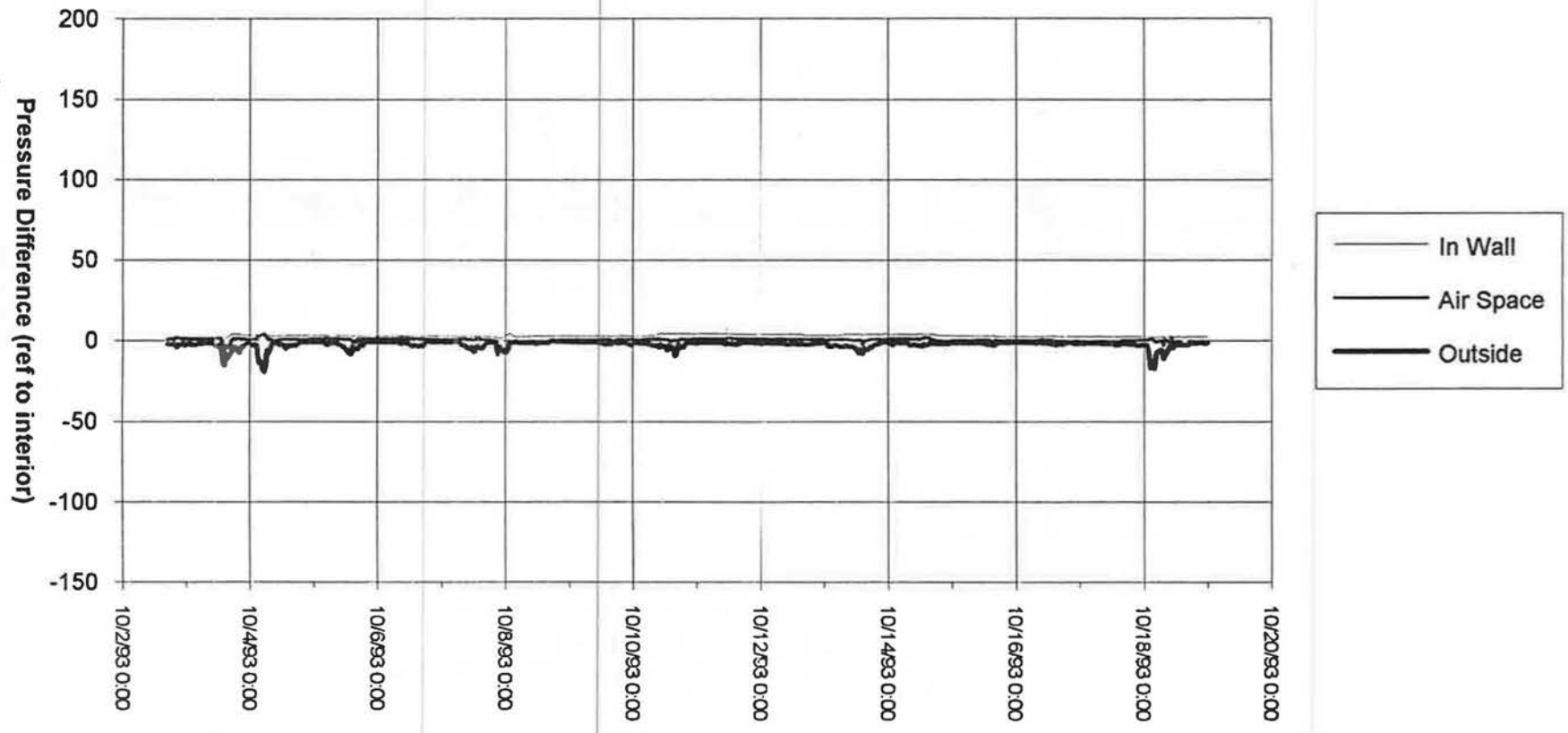



APCHQ House - EASE Construction Details  
North Wall - Stucco Cladding  
Mean Pressure Differences - January 1994

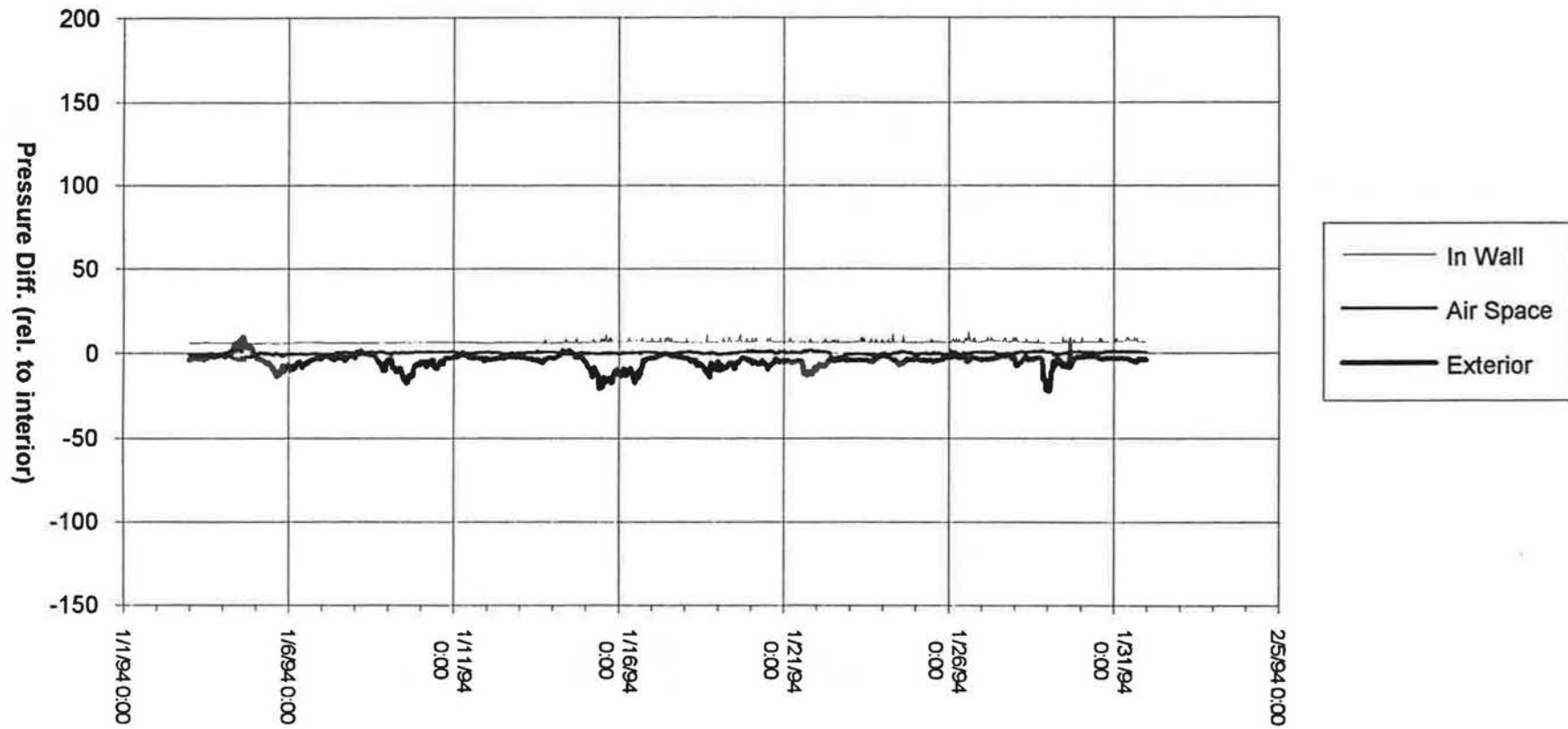

APCHQ House - EASE Construction Details  
North Wall - Stucco Cladding  
Mean Pressure Differences - February 1994

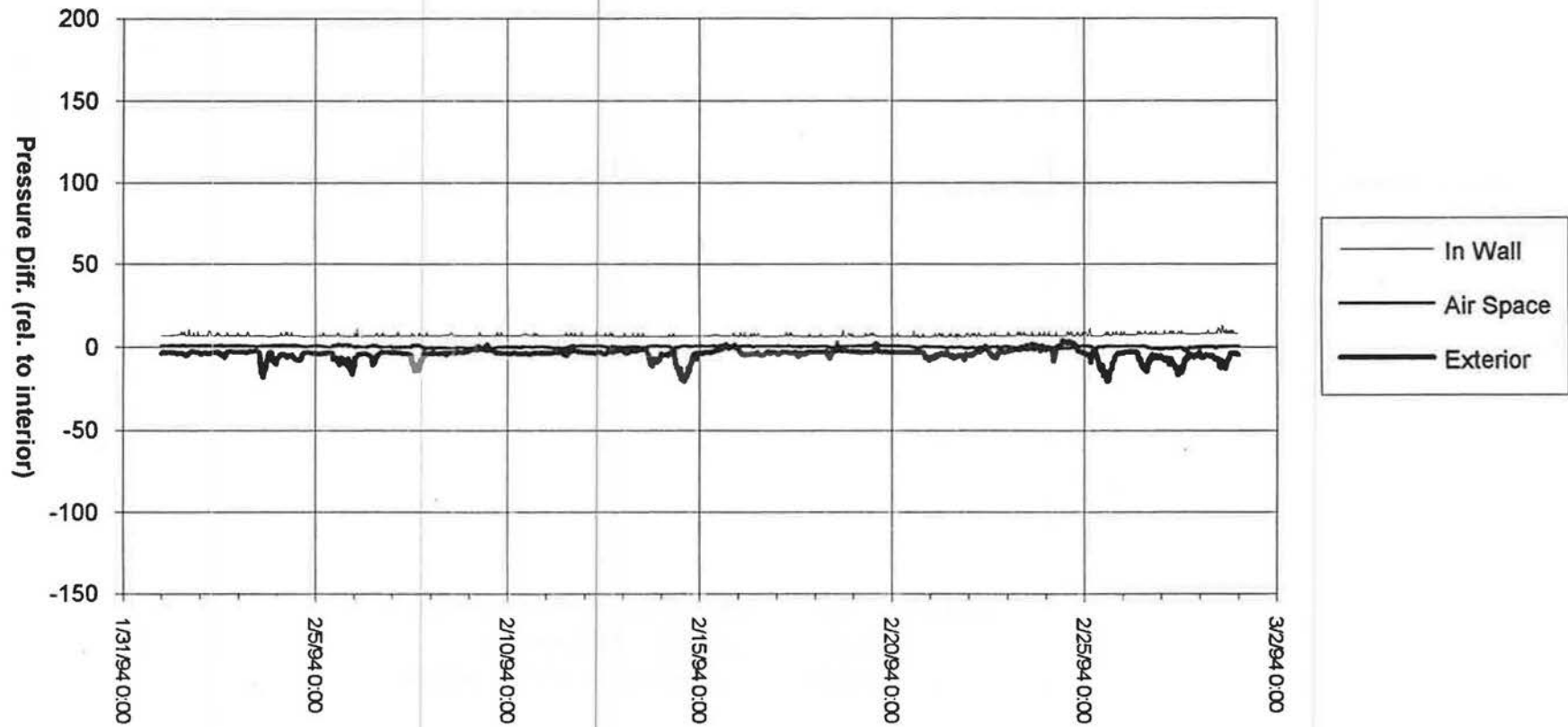

APCHQ House - EASE Construction Details  
North Wall - Stucco Cladding  
Mean Pressure Differences - March 1994

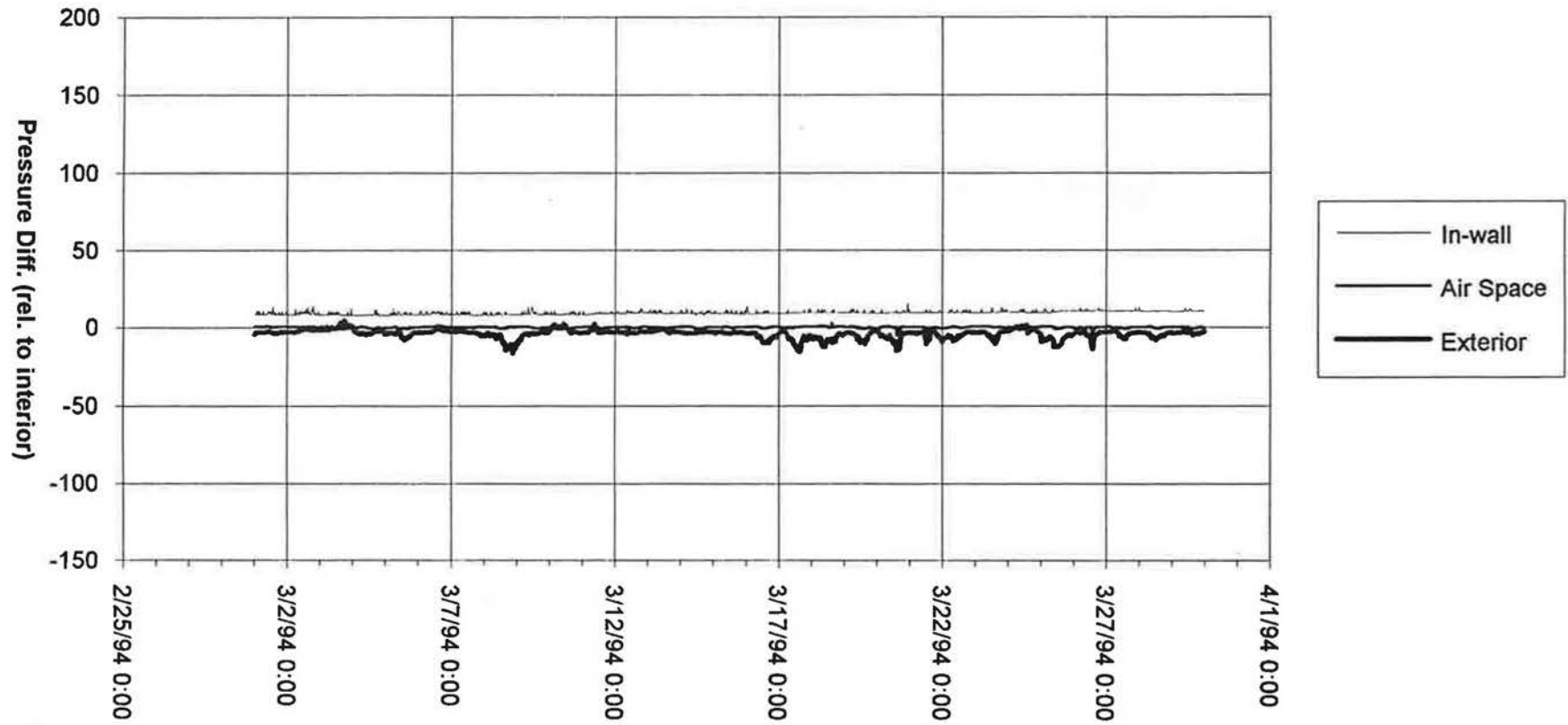

APCHQ House - EASE Construction Details  
North Wall - Stucco Cladding  
Mean Pressure Differences - April 1994

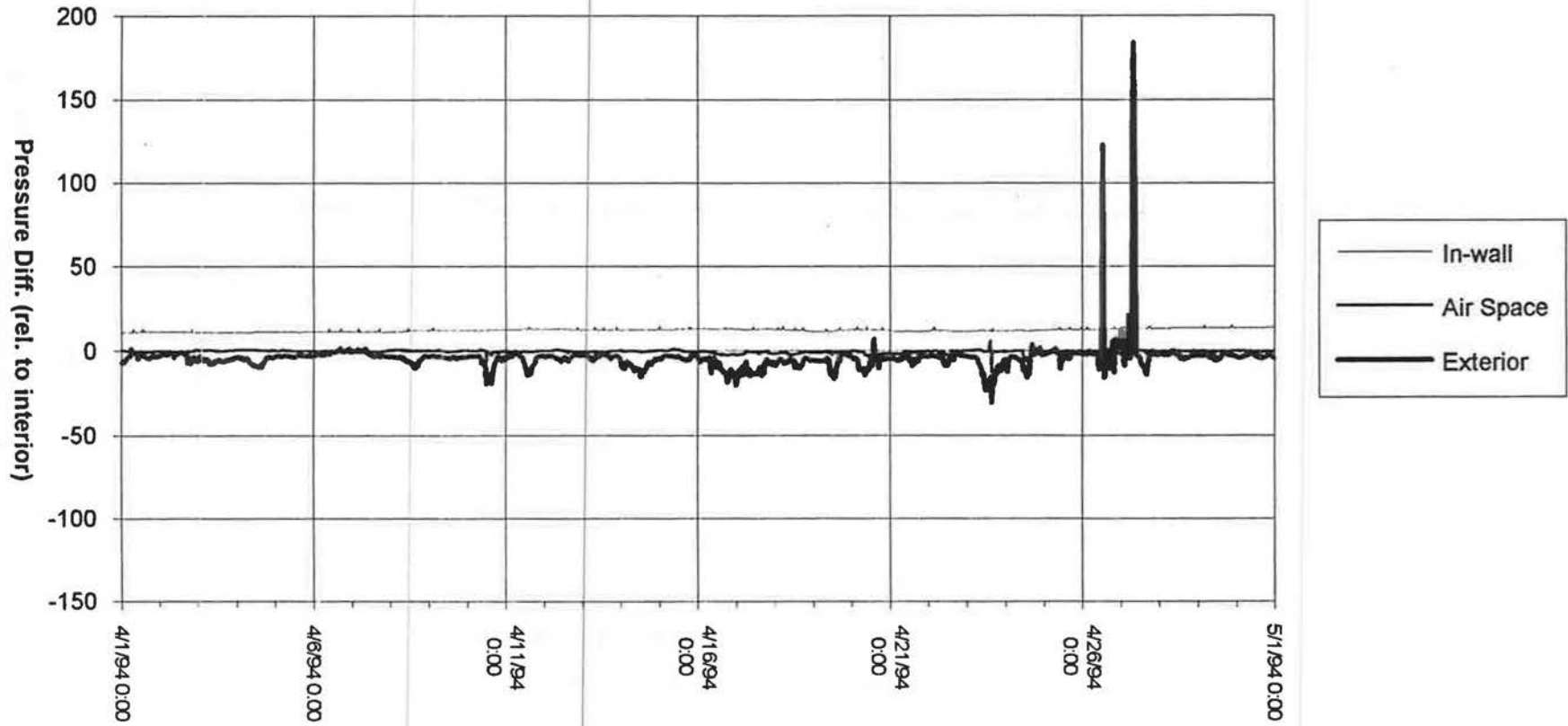

APCHQ House - EASE Construction Details  
North Wall - Stucco Cladding  
Mean Pressure Differences - May 1994

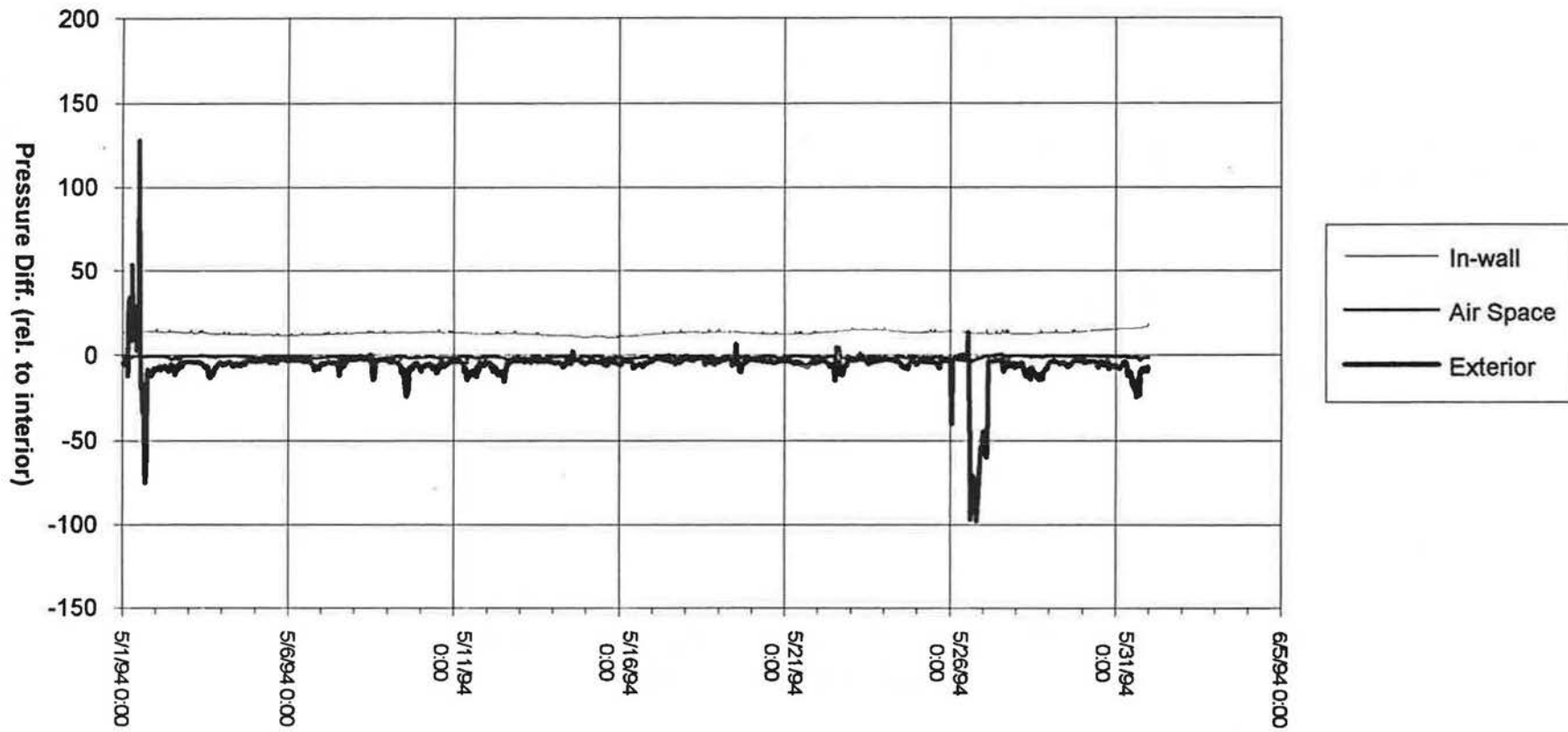

APCHQ House - EASE Construction Details  
North Wall - Stucco Cladding  
Mean Pressure Differences - June 1994

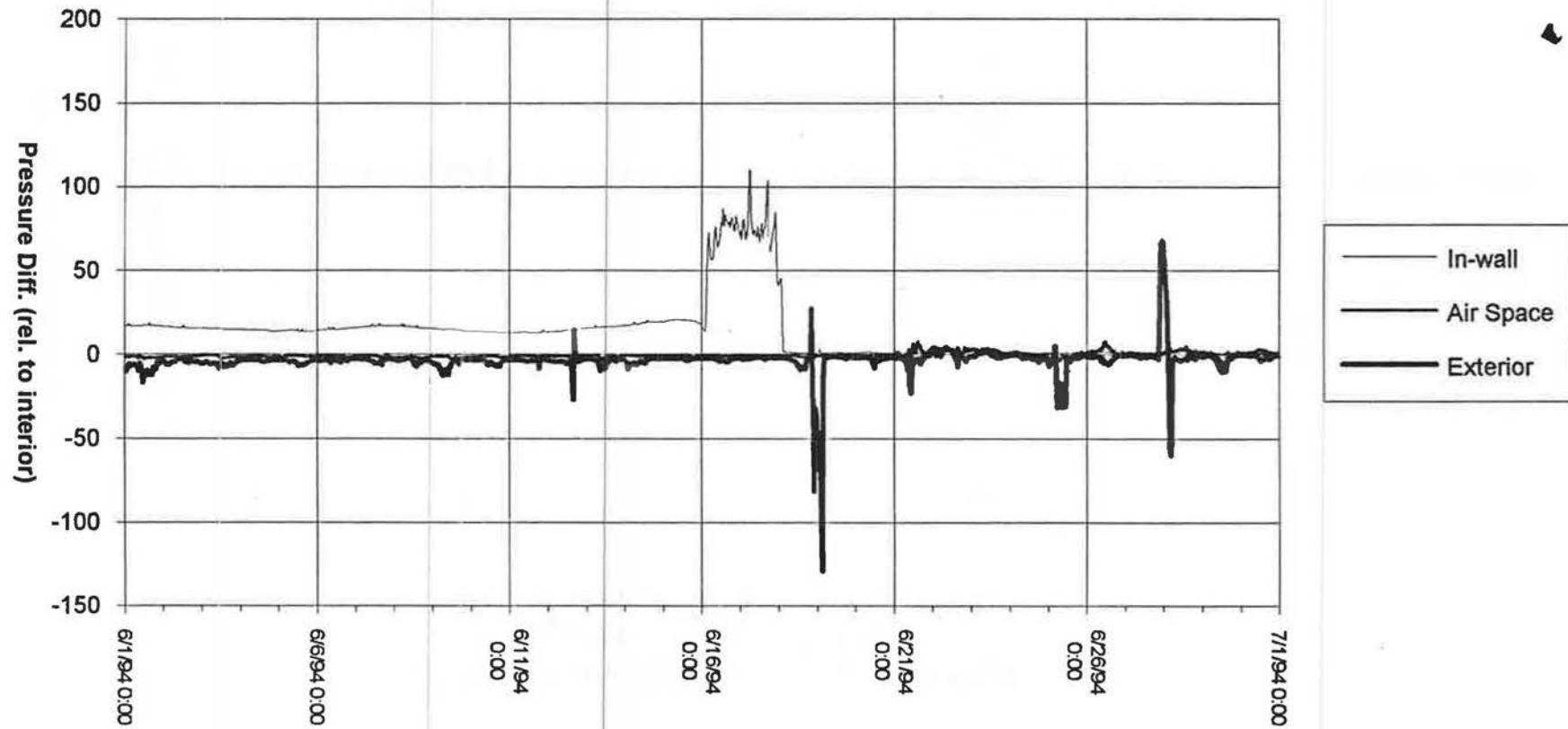

APCHQ House - EASE Construction Details  
North Wall - Stucco Cladding  
In Wall Ambient/In Wall Dew Point Temperatures - October 1993

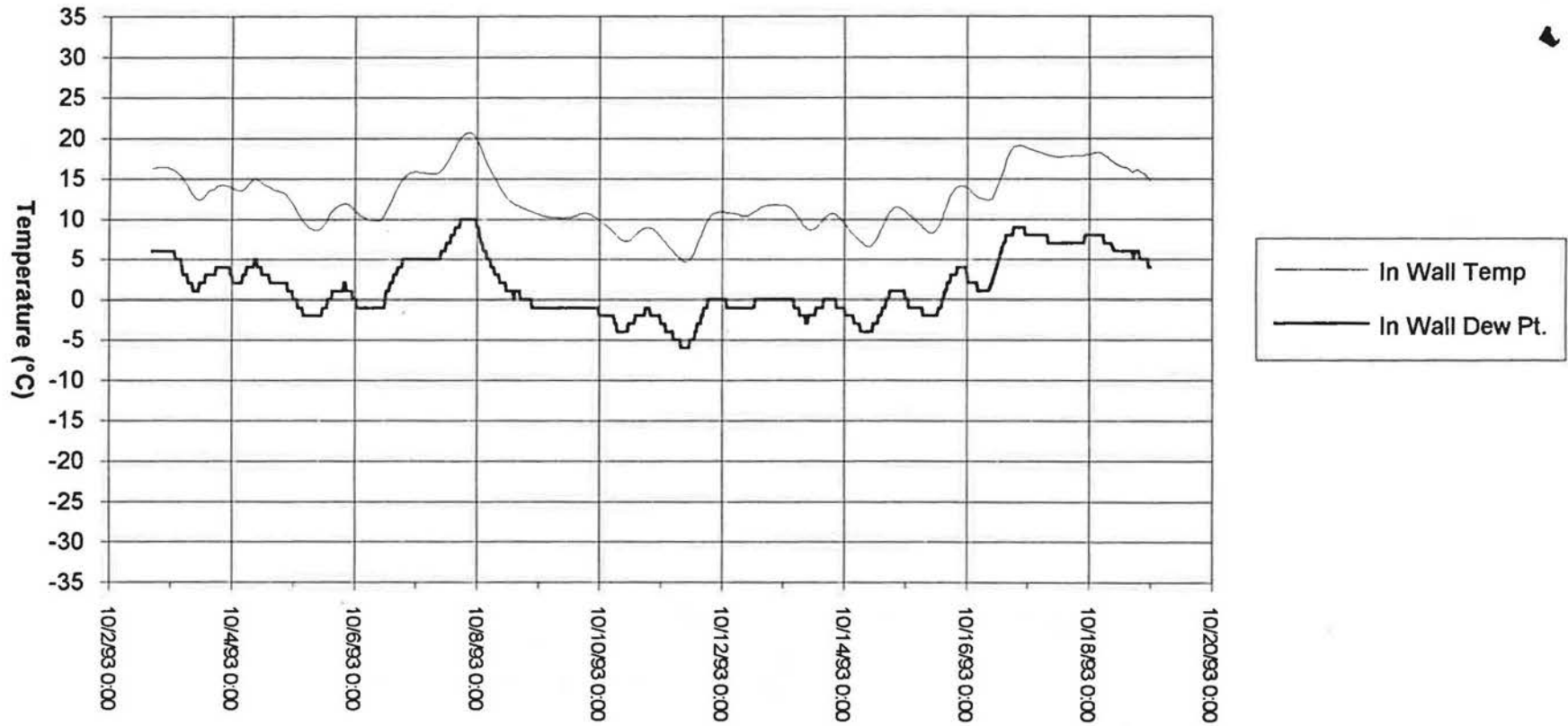

**APCHQ House - EASE Construction Details  
North Wall - Stucco Cladding  
In Wall Ambient/Dew Point Temperatures - January 1994**

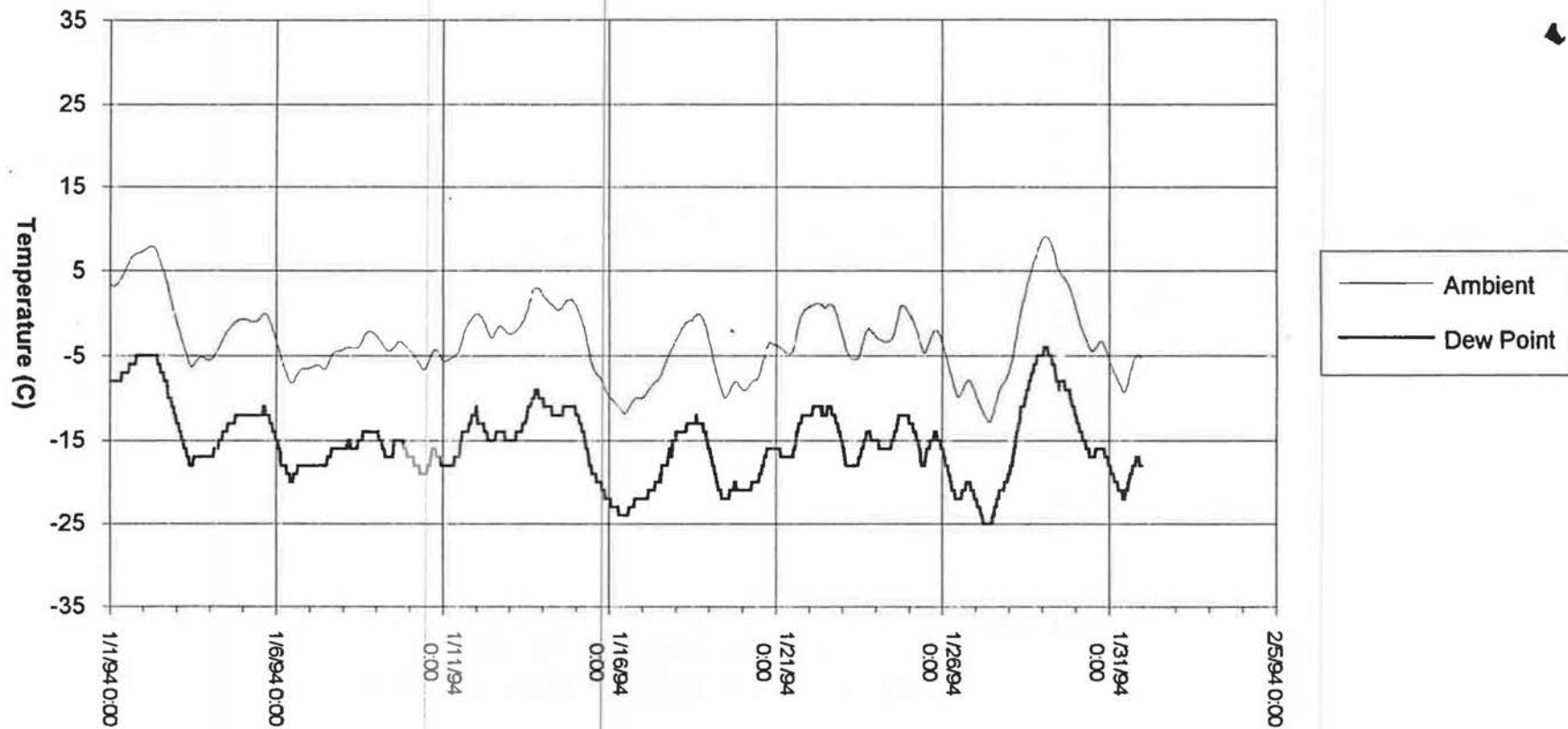



**APCHQ House - EASE Construction Details  
North Wall - Stucco Cladding  
In Wall Ambient/Dew Point Temperatures - February 1994**

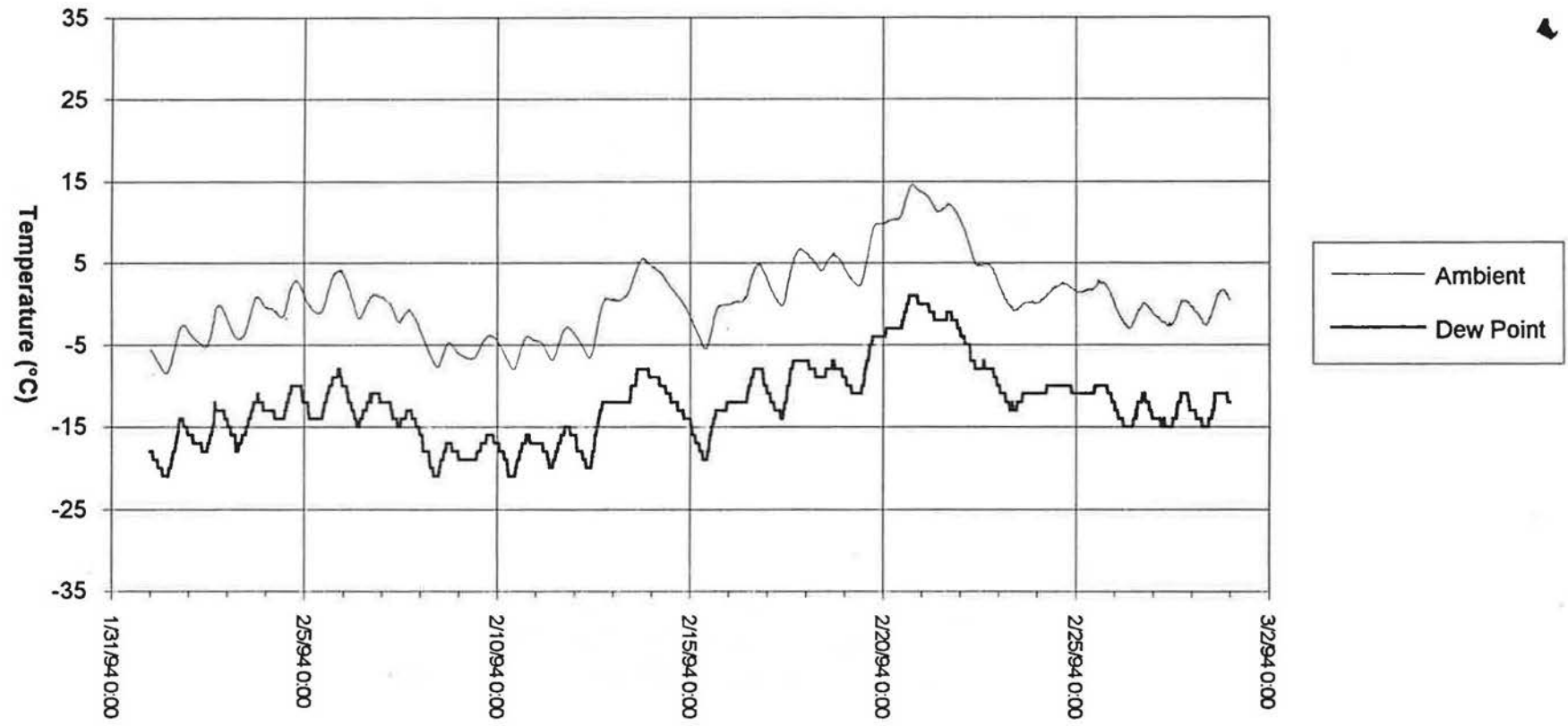

**APCHQ House - EASE Construction Details  
North Wall - Stucco Cladding  
In Wall Ambient/Dew Point Temperatures - March 1994**

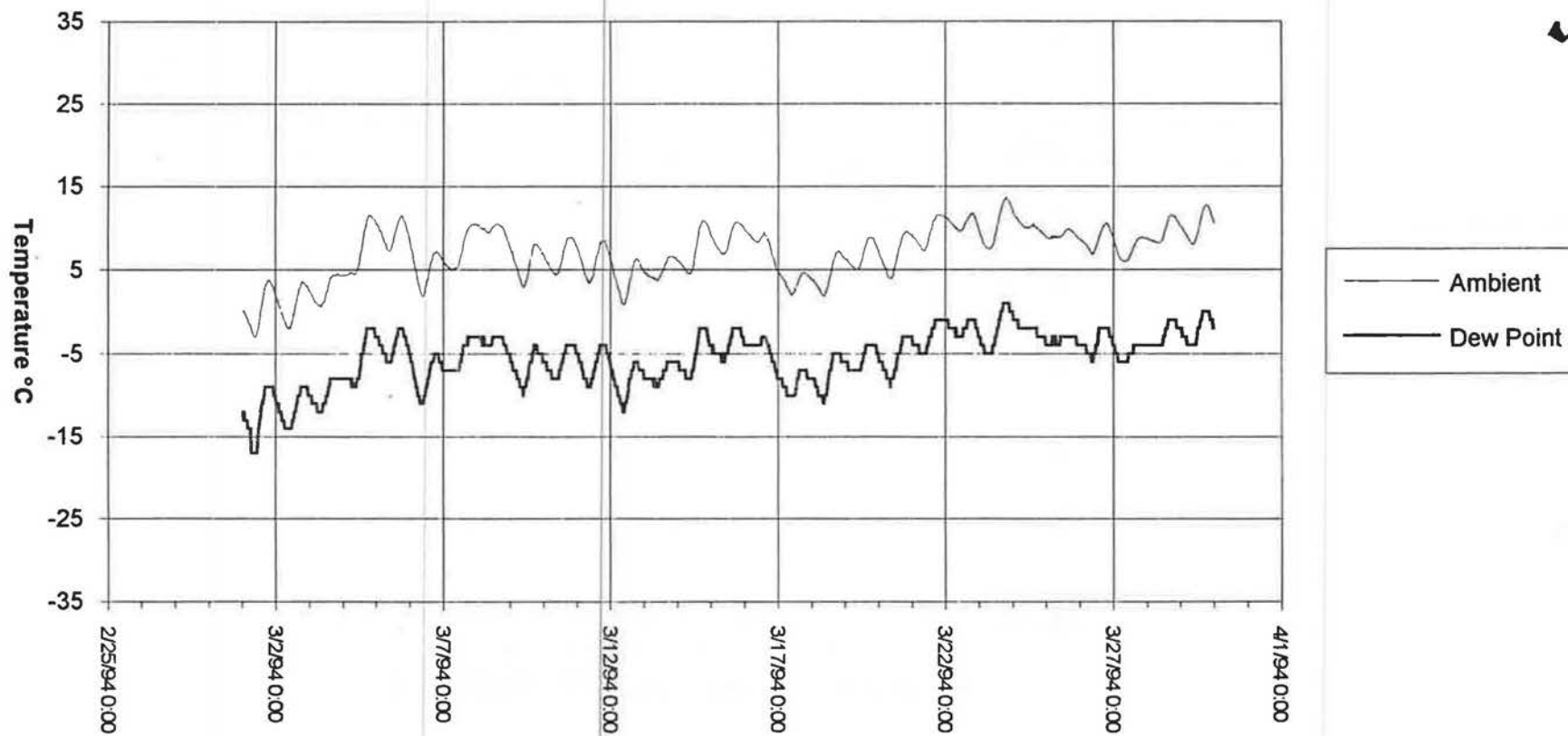

APCHQ House - EASE Construction Details  
North Wall - Stucco Cladding  
In Wall Ambient/Dew Point Temperatures - April 1994

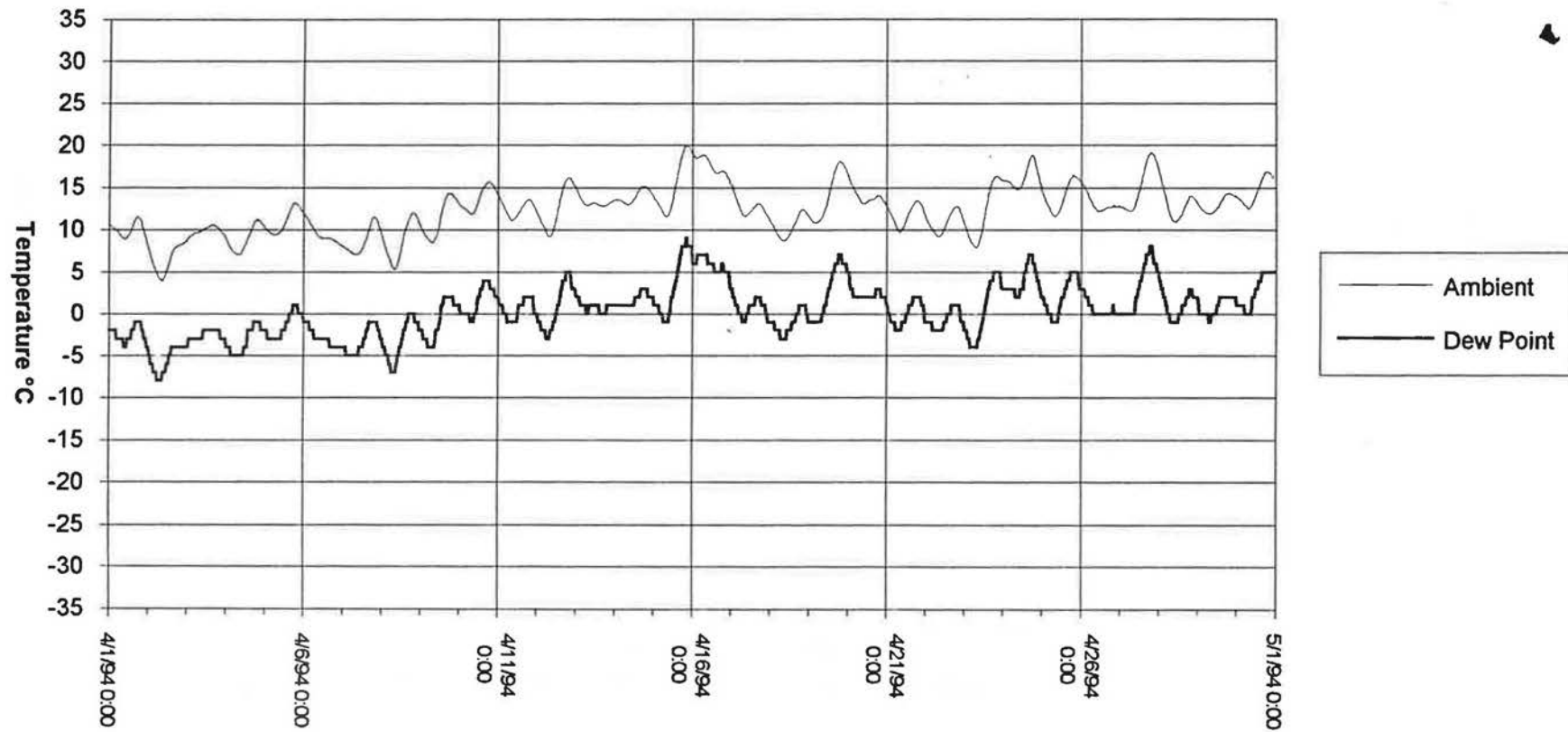

**APCHQ House - EASE Construction Details  
North Wall - Stucco Cladding  
In Wall Ambient/Dew Point Temperatures - May 1994**

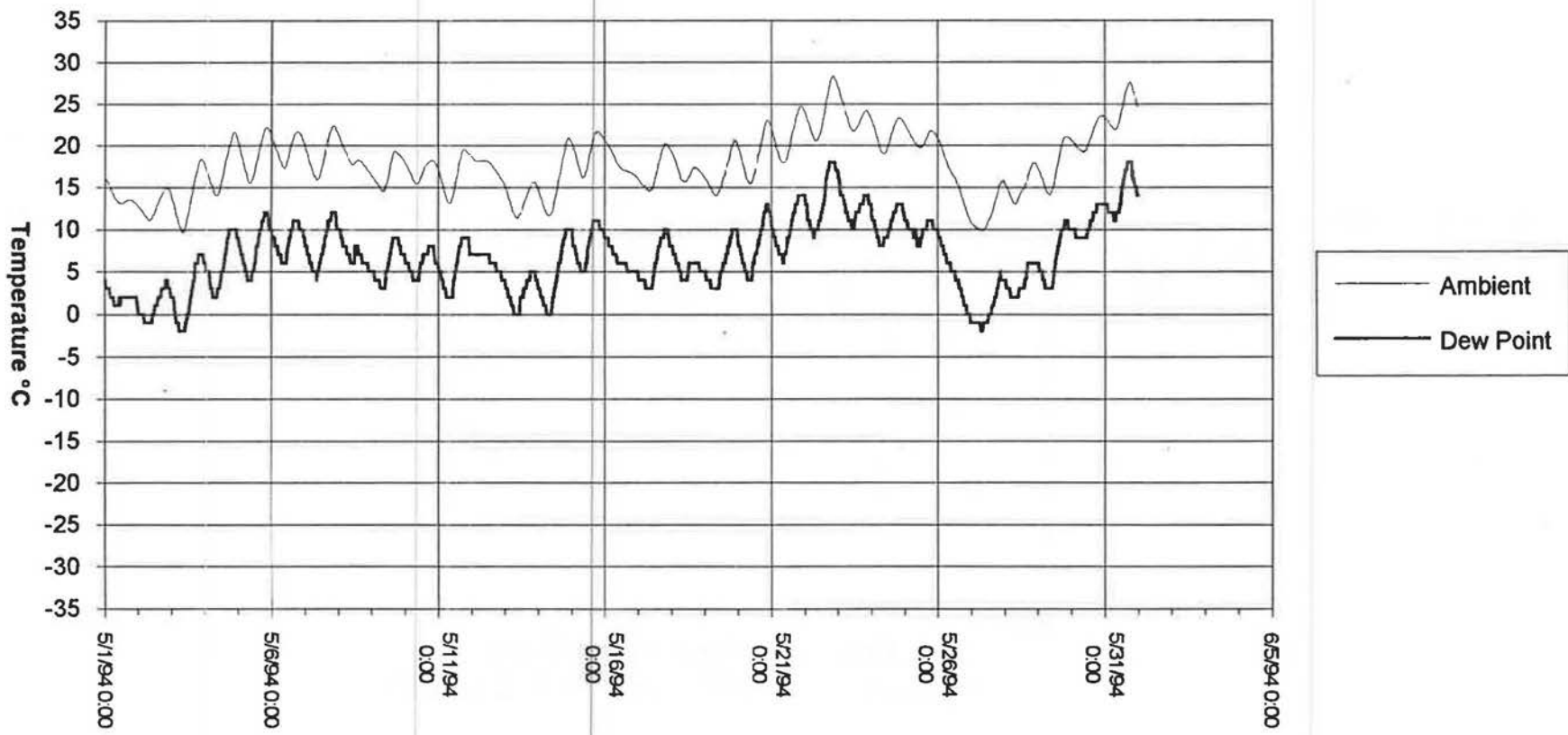

**APCHQ House - EASE Construction Details  
North Wall - Stucco Cladding  
In Wall Ambient/Dew Point Temperatures - June 1994**

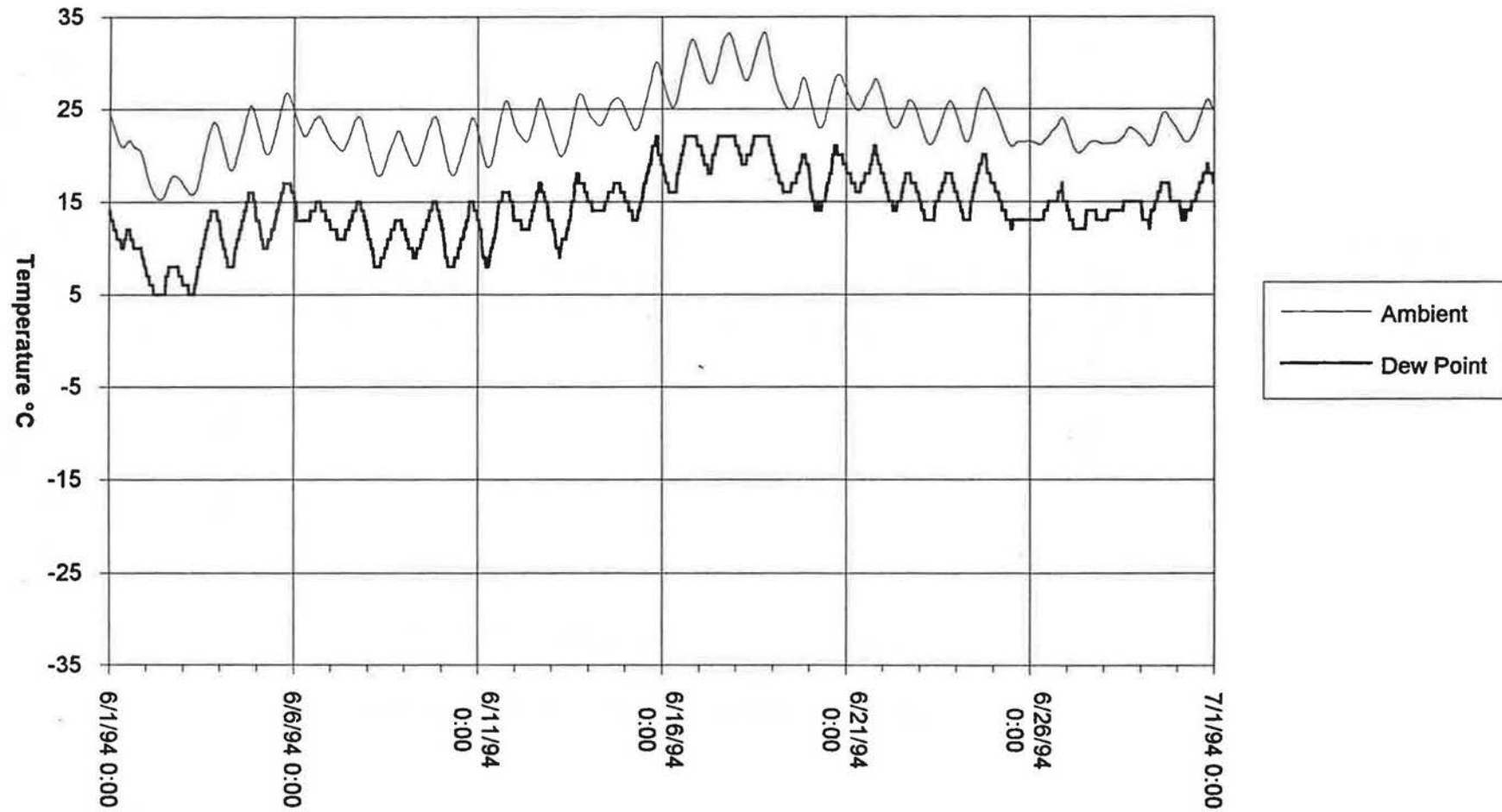

APCHQ House - EASE Construction Details  
Southwest Wall - Brick Cladding  
Average Pressure Differences - October 1993

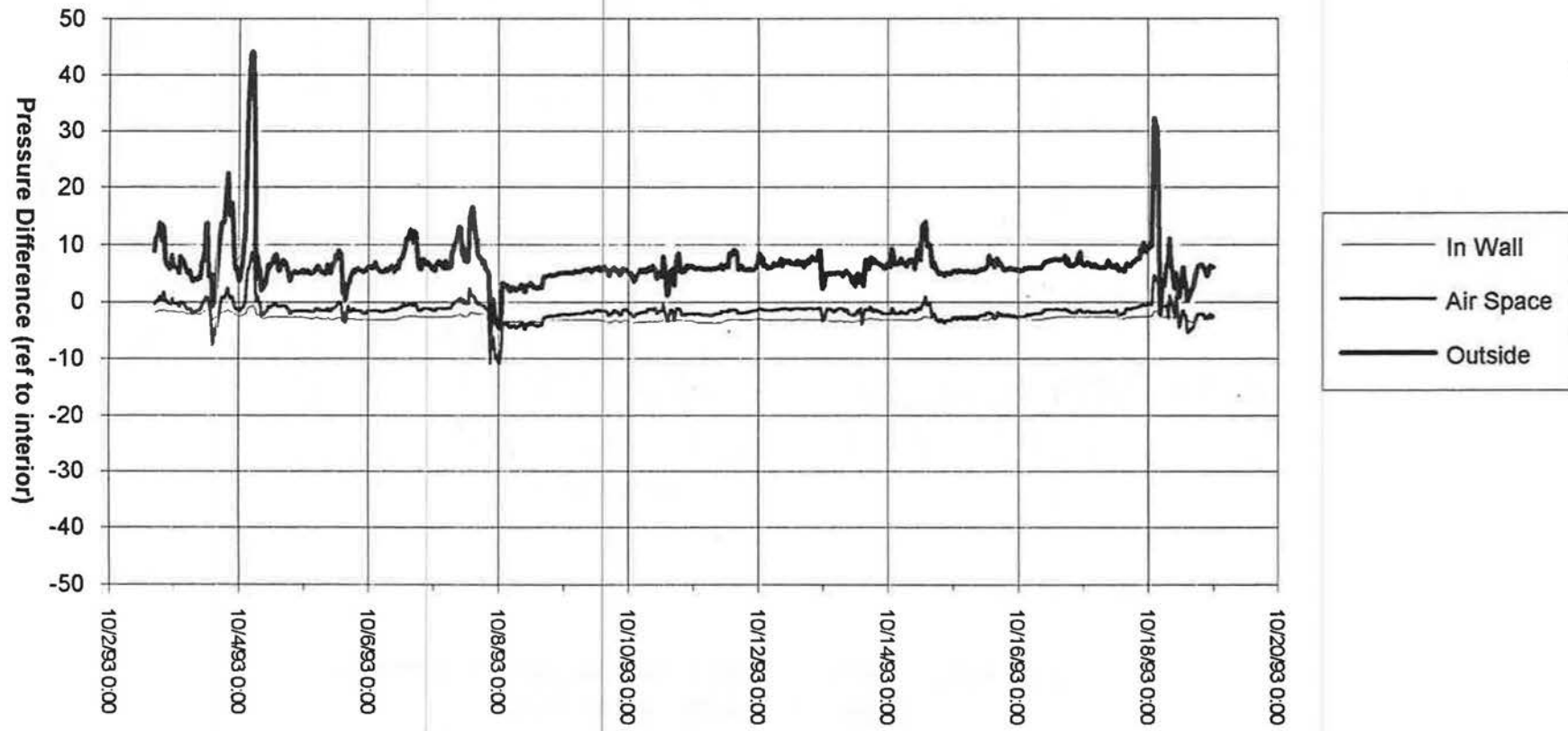

APCHQ House - EASE Construction Details  
Southwest Wall - Brick Cladding  
Average Pressure Differences - February 1994

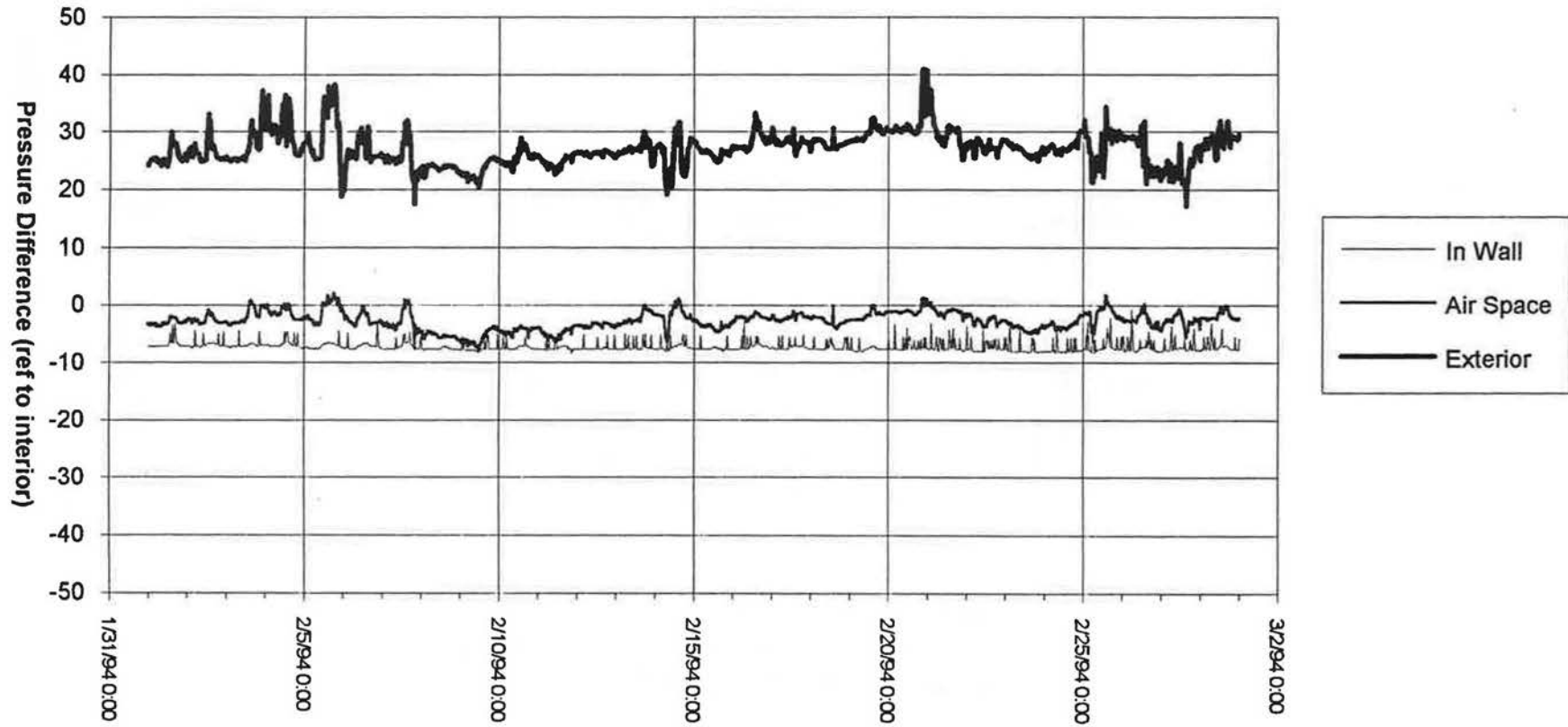

**APCHQ House - EASE Construction Details  
Southwest Wall - Brick Cladding  
Average Pressure Differences - January 1994**

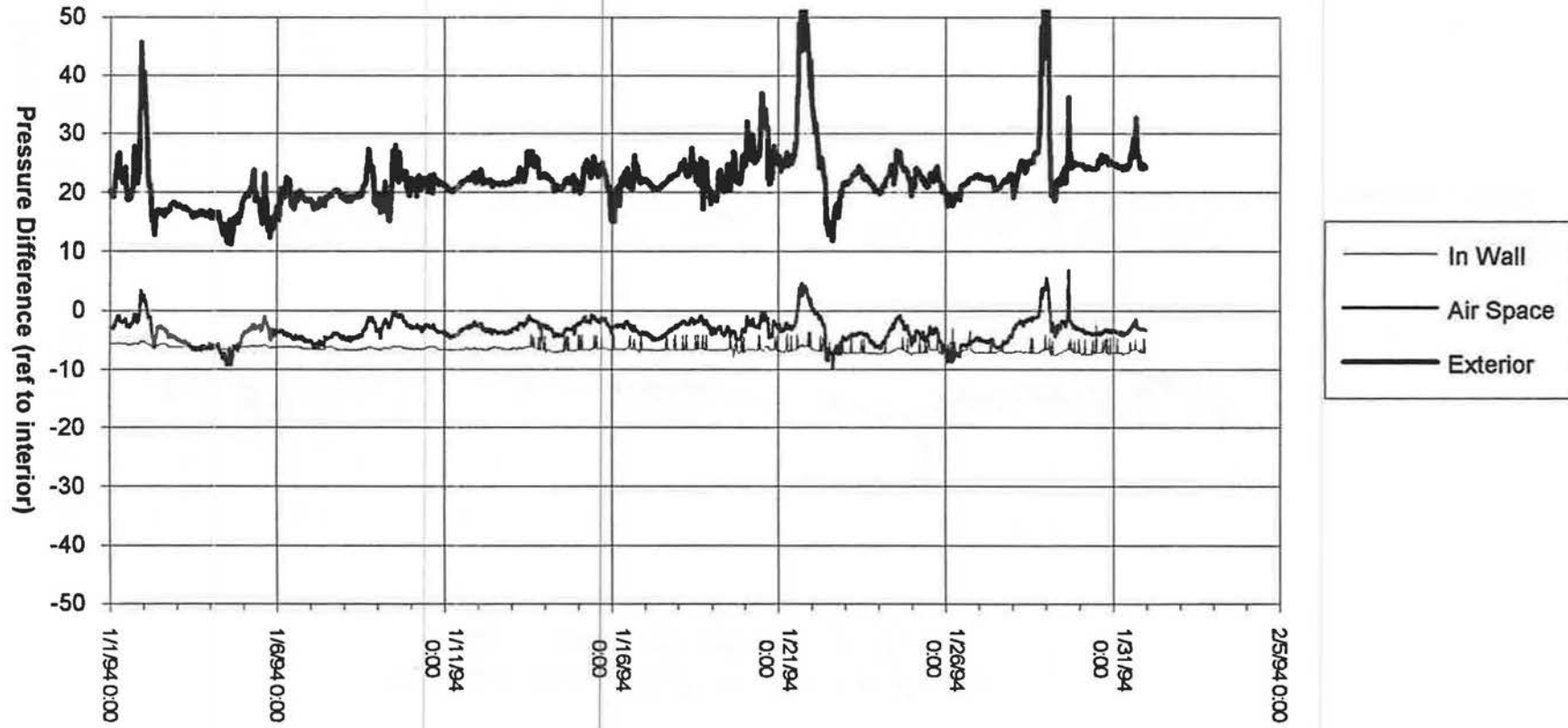



APCHQ House - EASE Construction Details  
Southwest Wall - Brick Cladding  
Mean Pressure Differences - March 1994

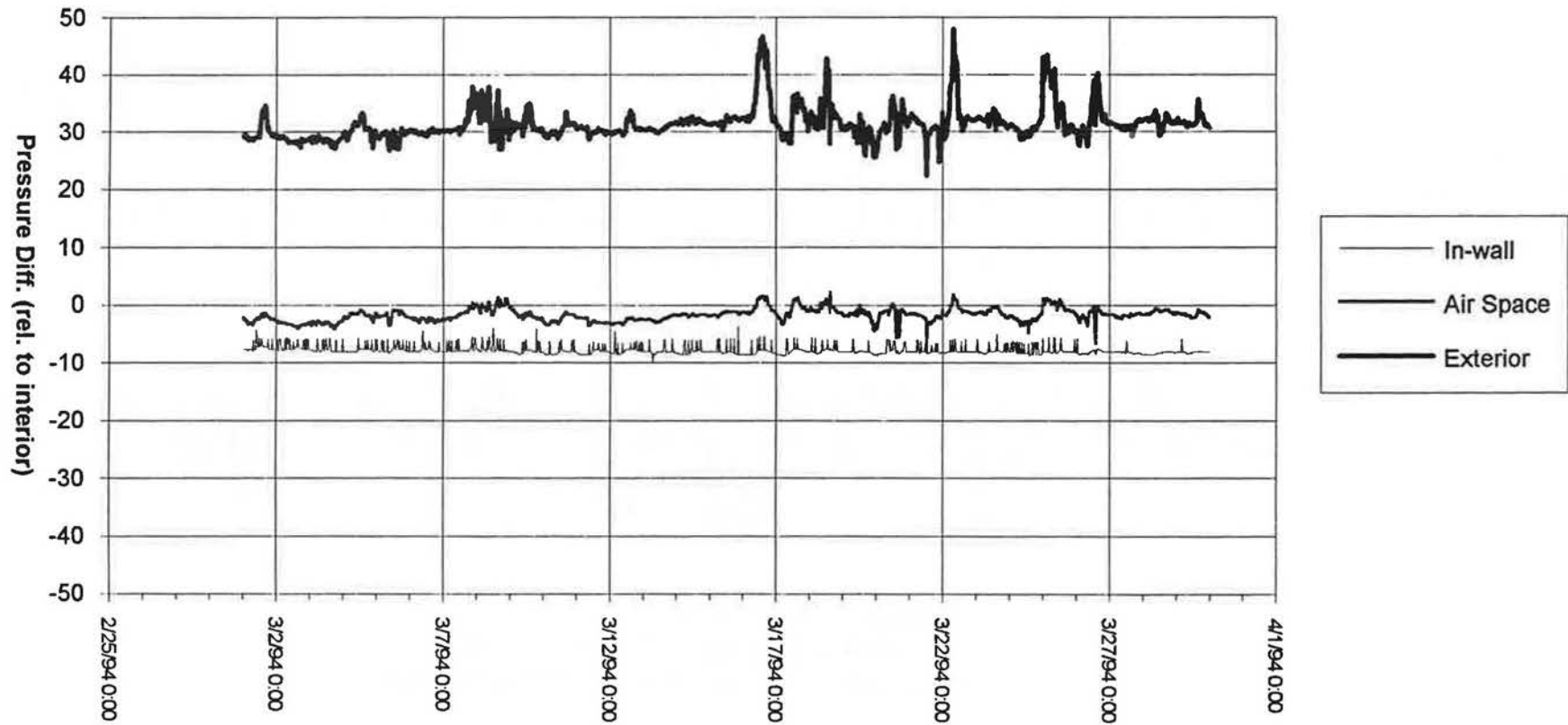

APCHQ House - EASE Construction Details  
Southwest Wall - Brick Cladding  
Mean Pressure Differences - April 1994

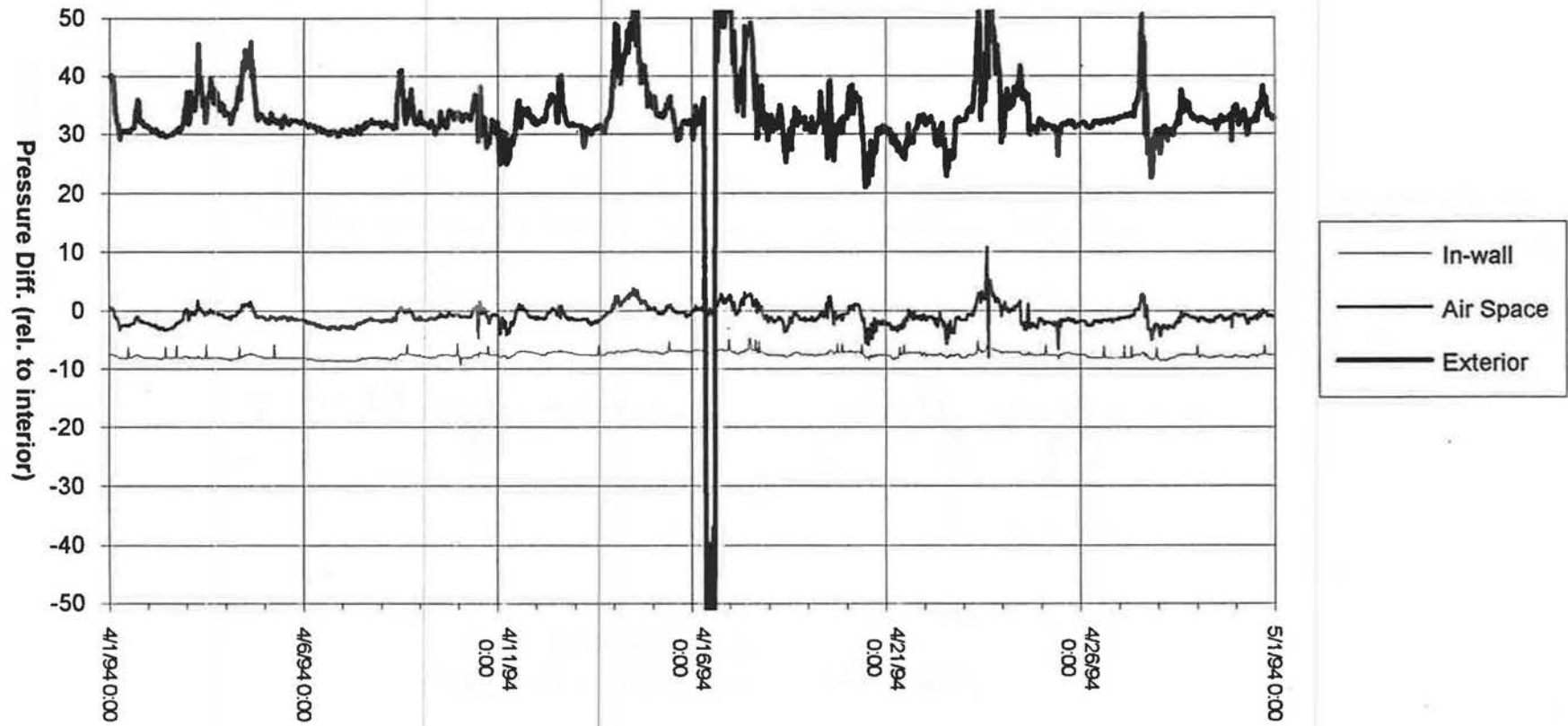

APCHQ House - EASE Construction Details  
Southwest Wall - Brick Cladding  
Pressure Differences - May 1994

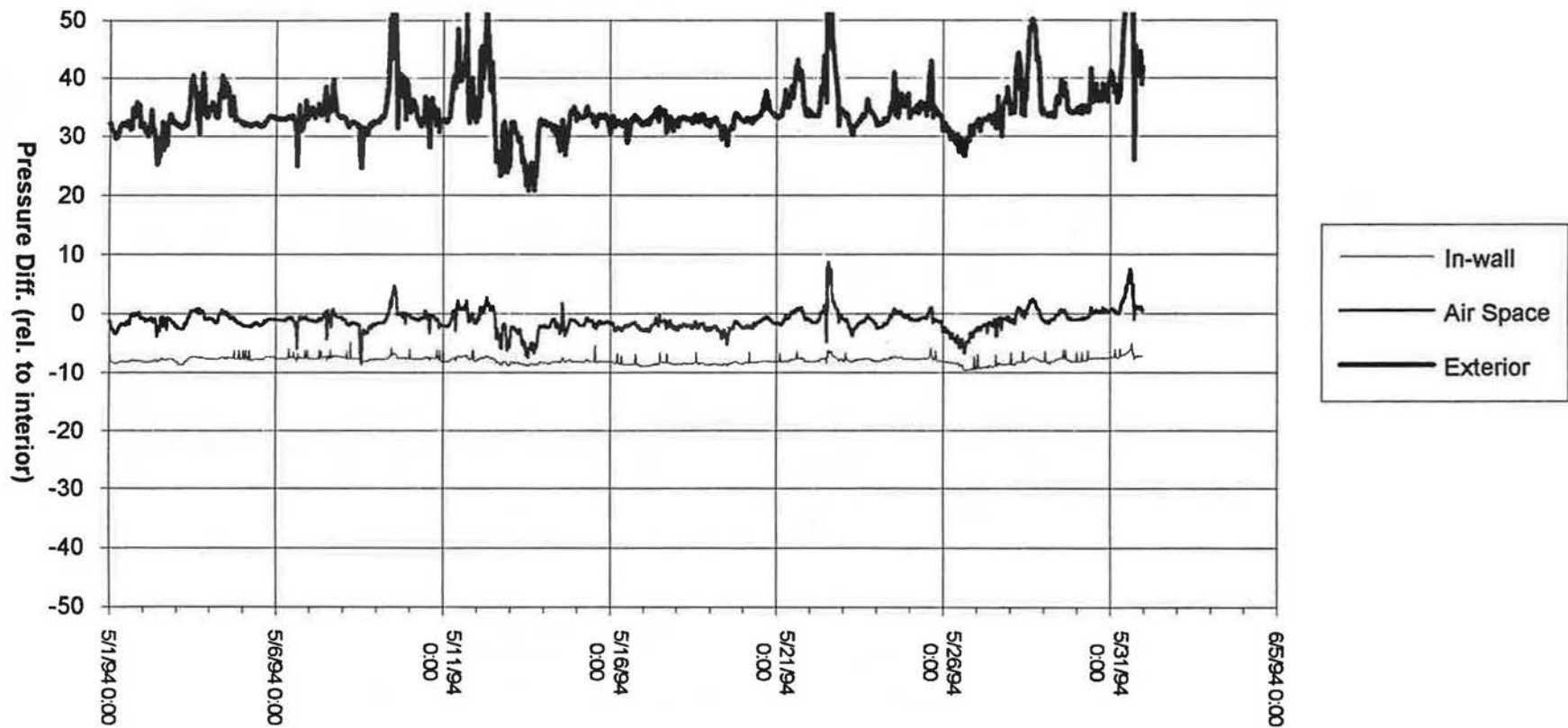

APCHQ House - EASE Construction Details  
Southwest Wall - Brick Cladding  
Pressure Differences - June 1994

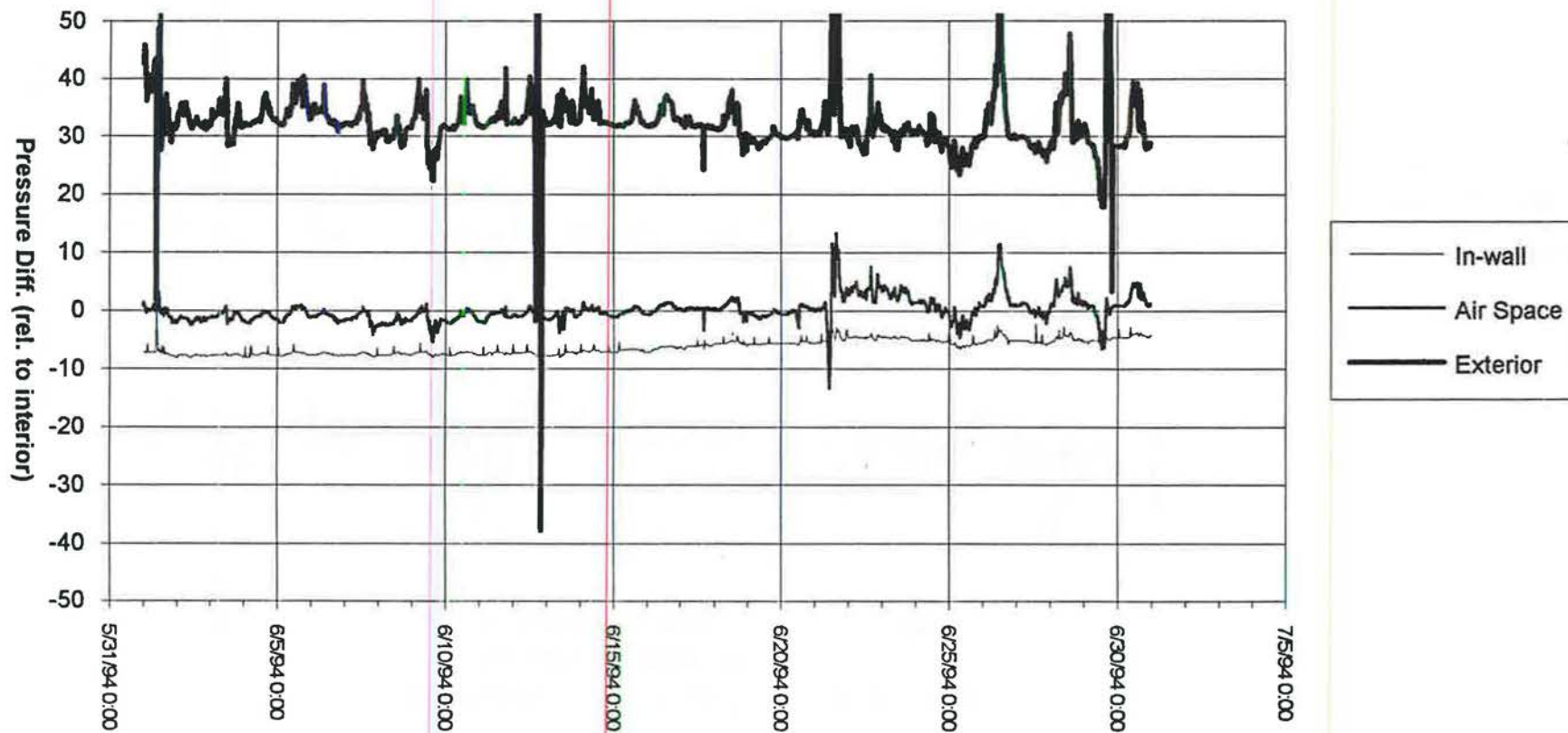

APCHQ House - EASE Construction Details  
Southwest Wall - Brick Cladding  
Average Pressure Differences - October 1993

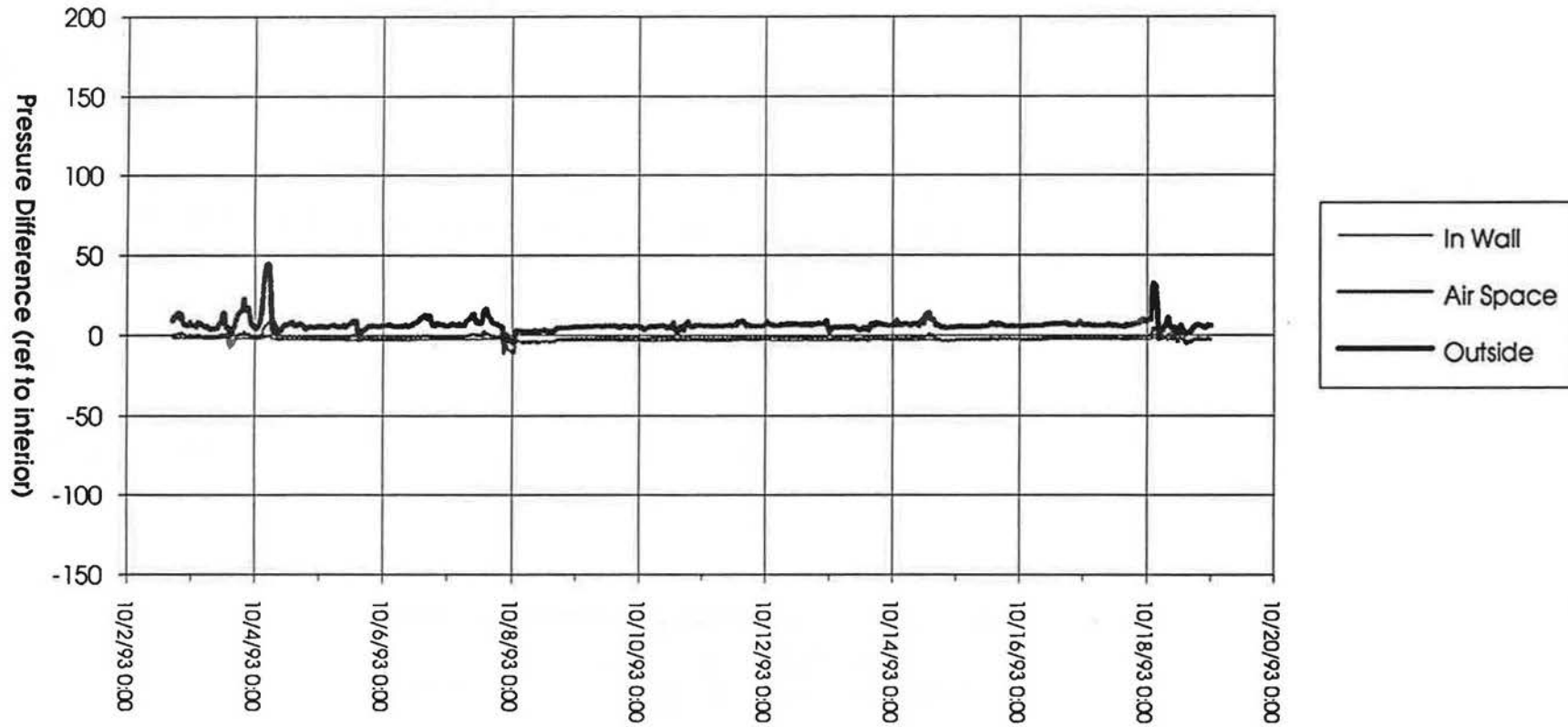

**APCHQ House - EASE Construction Details**  
**Southwest Wall - Brick Cladding**  
**Average Pressure Differences - January 1994**

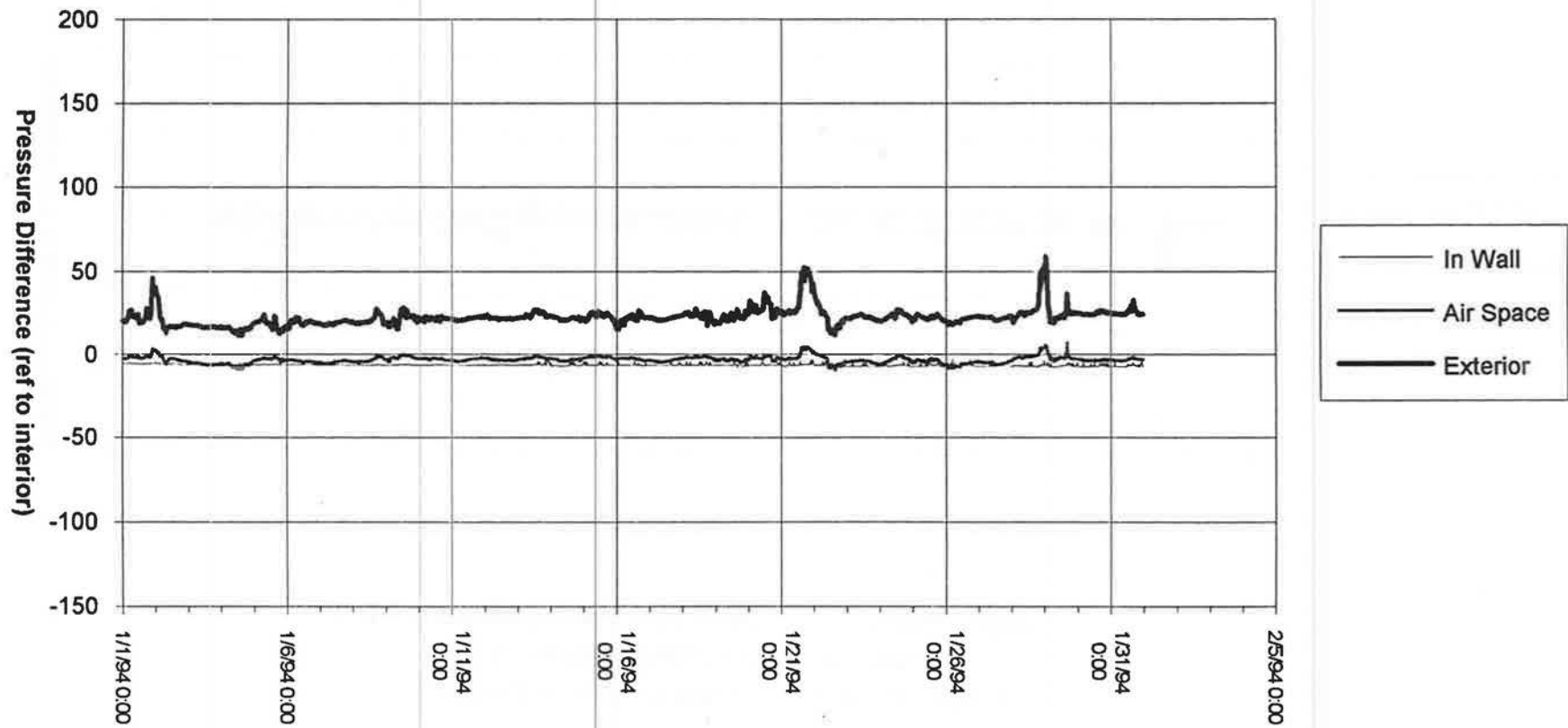

**APCHQ House - EASE Construction Details  
Southwest Wall - Brick Cladding  
Average Pressure Differences - February 1994**

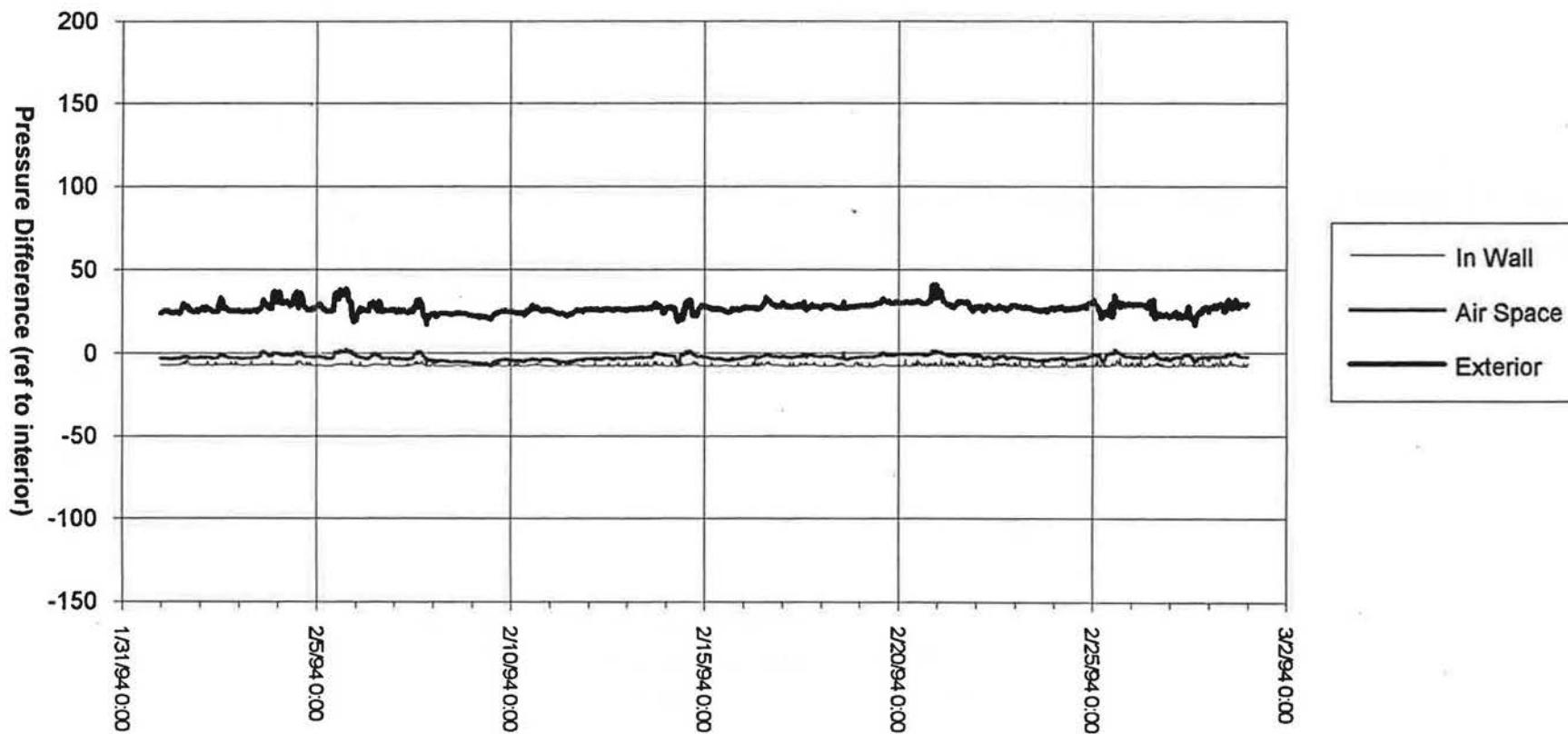

**APCHQ House - EASE Construction Details**  
**Southwest Wall - Brick Cladding**  
**Mean Pressure Differences - March 1994**

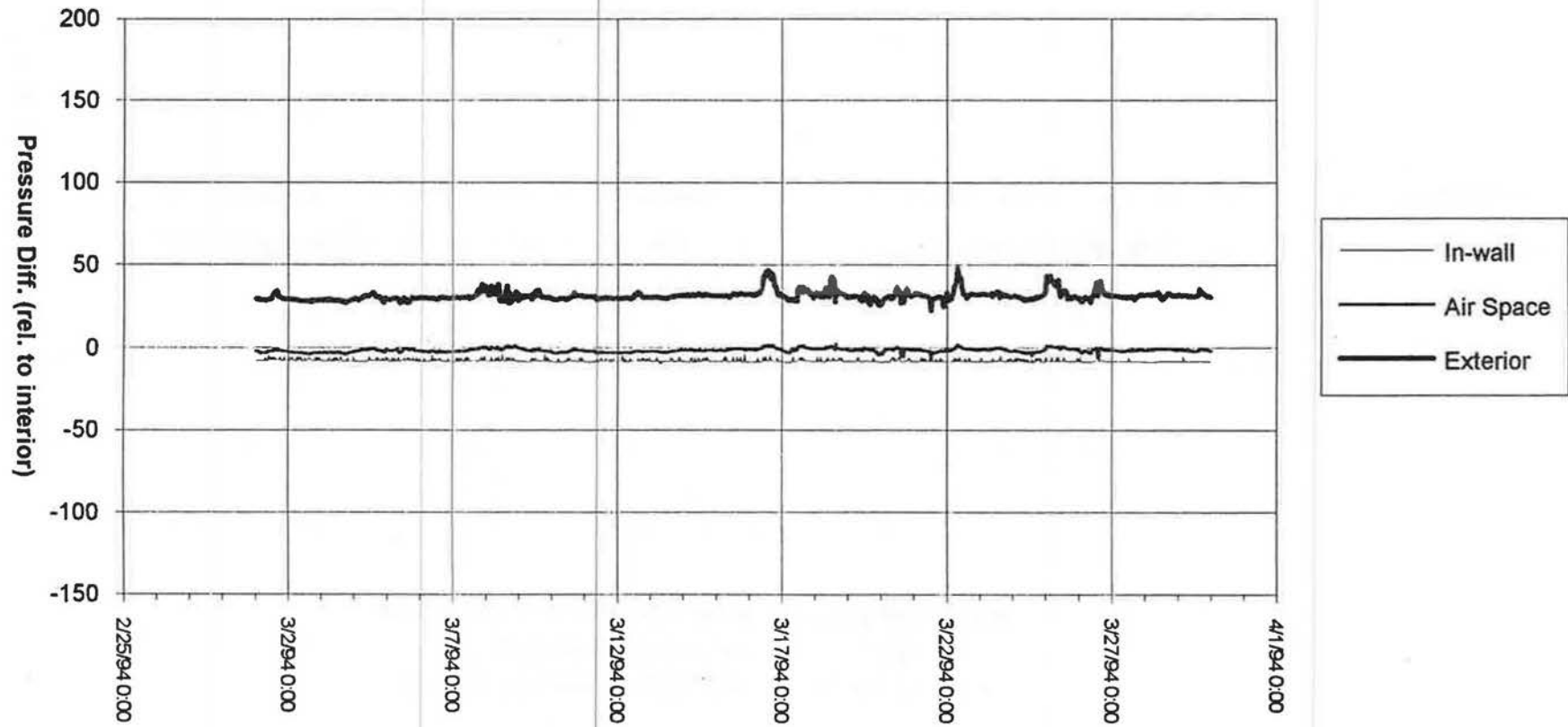



APCHQ House - EASE Construction Details  
Southwest Wall - Brick Cladding  
Mean Pressure Differences - April 1994

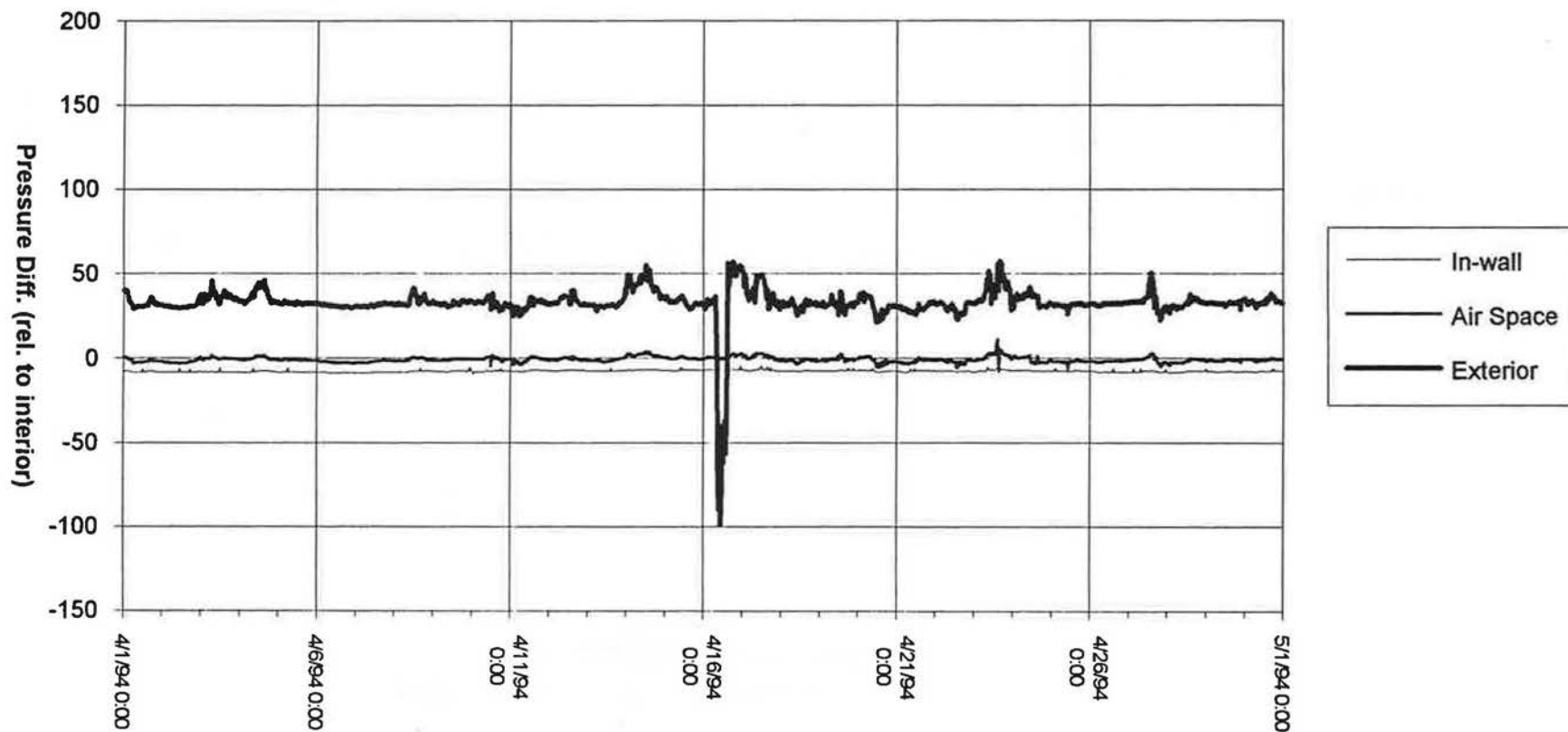

**APCHQ House - EASE Construction Details**  
**Southwest Wall - Brick Cladding**  
**Pressure Differences - May 1994**

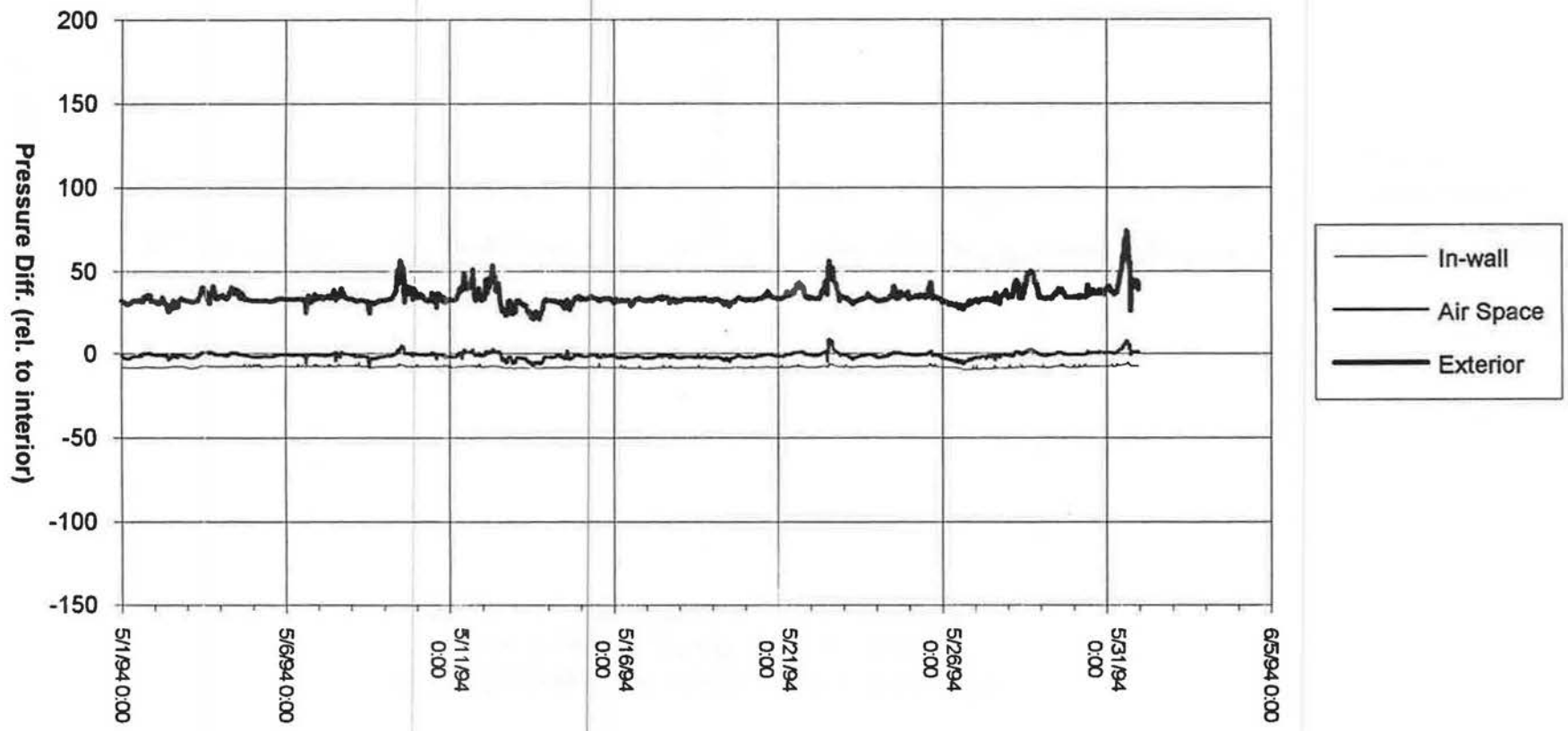

APCHQ House - EASE Construction Details  
Southwest Wall - Brick Cladding  
Pressure Differences - June 1994

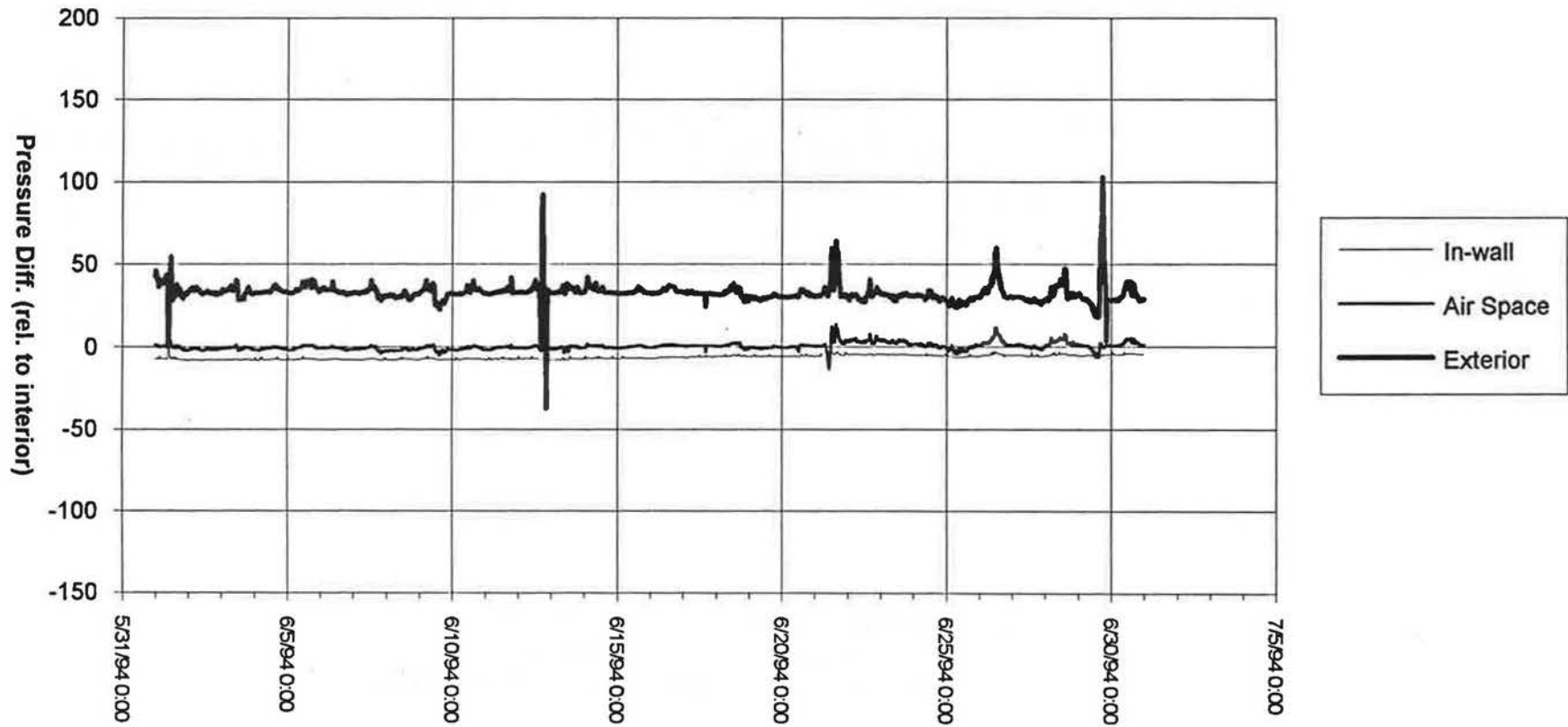

**APCHQ House - EASE Construction Details**  
**Southwest Wall - Brick Cladding**  
**In Wall Ambient/Dew Point Temperatures - October 1993**

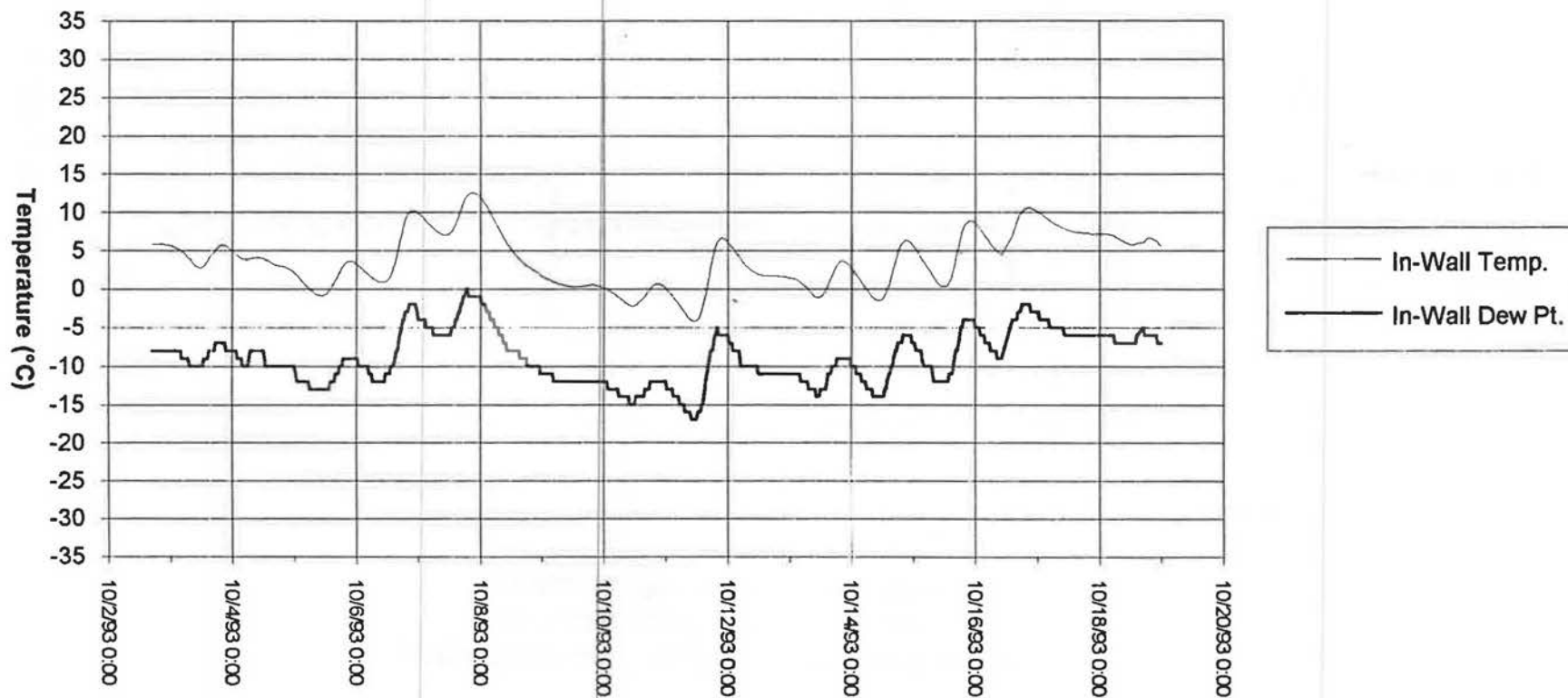

**APCHQ House - EASE Construction Details  
Southwest Wall - Brick Cladding  
In Wall Ambient/Dew Point Temperatures - January 1994**

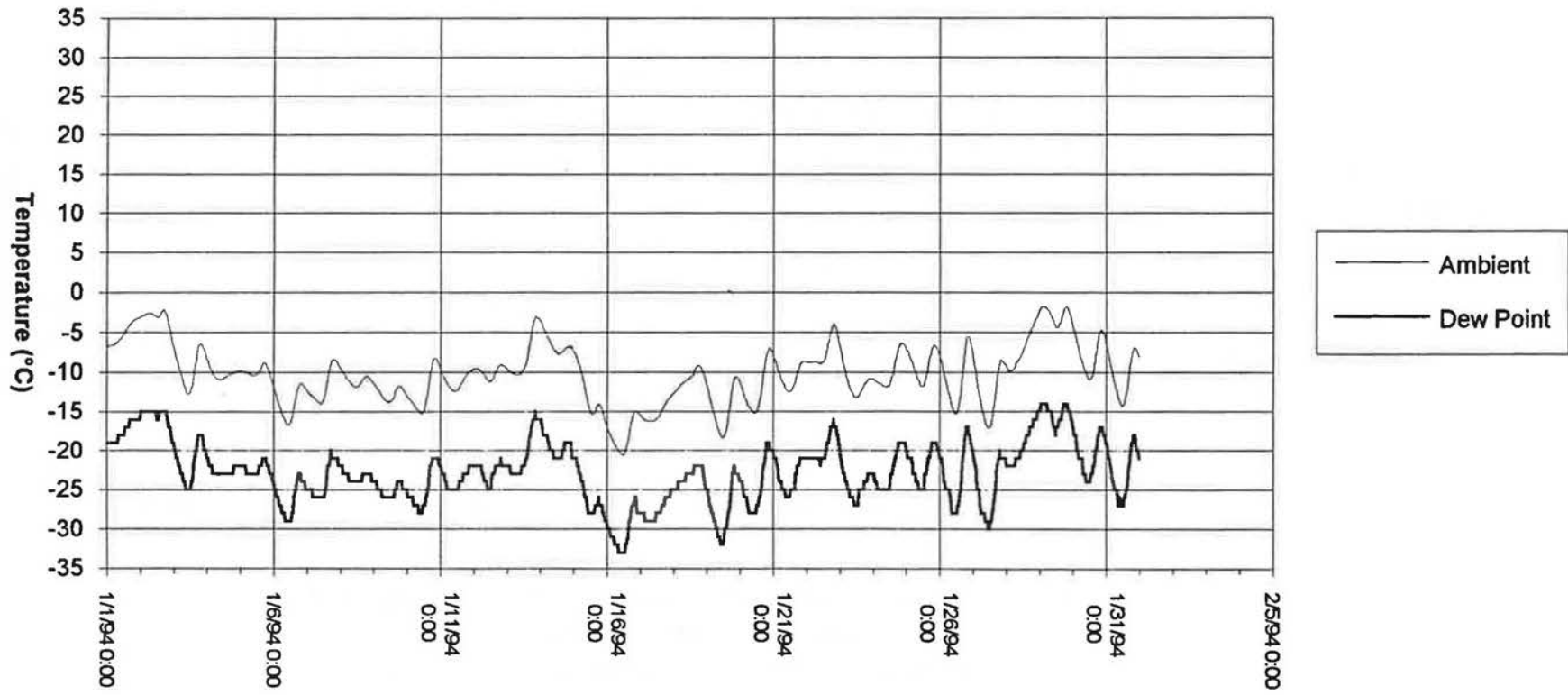

**APCHQ House - EASE Construction Details  
Southwest Wall - Brick Cladding  
In Wall Ambient/Dew Point Temperatures - February 1994**

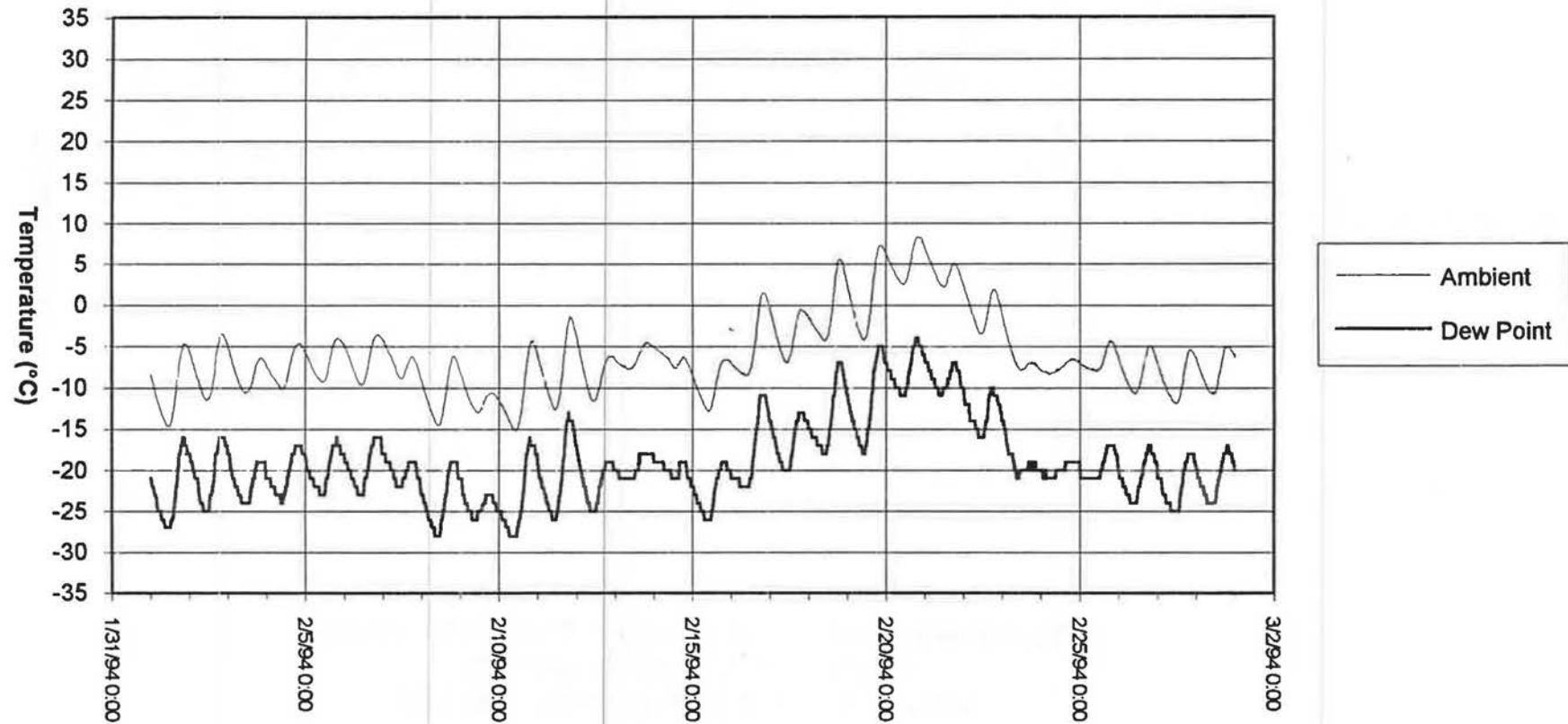

APCHQ House - EASE Construction Details  
Southwest Wall - Brick Cladding  
In Wall Ambient/Dew Point Temperatures - March 1994

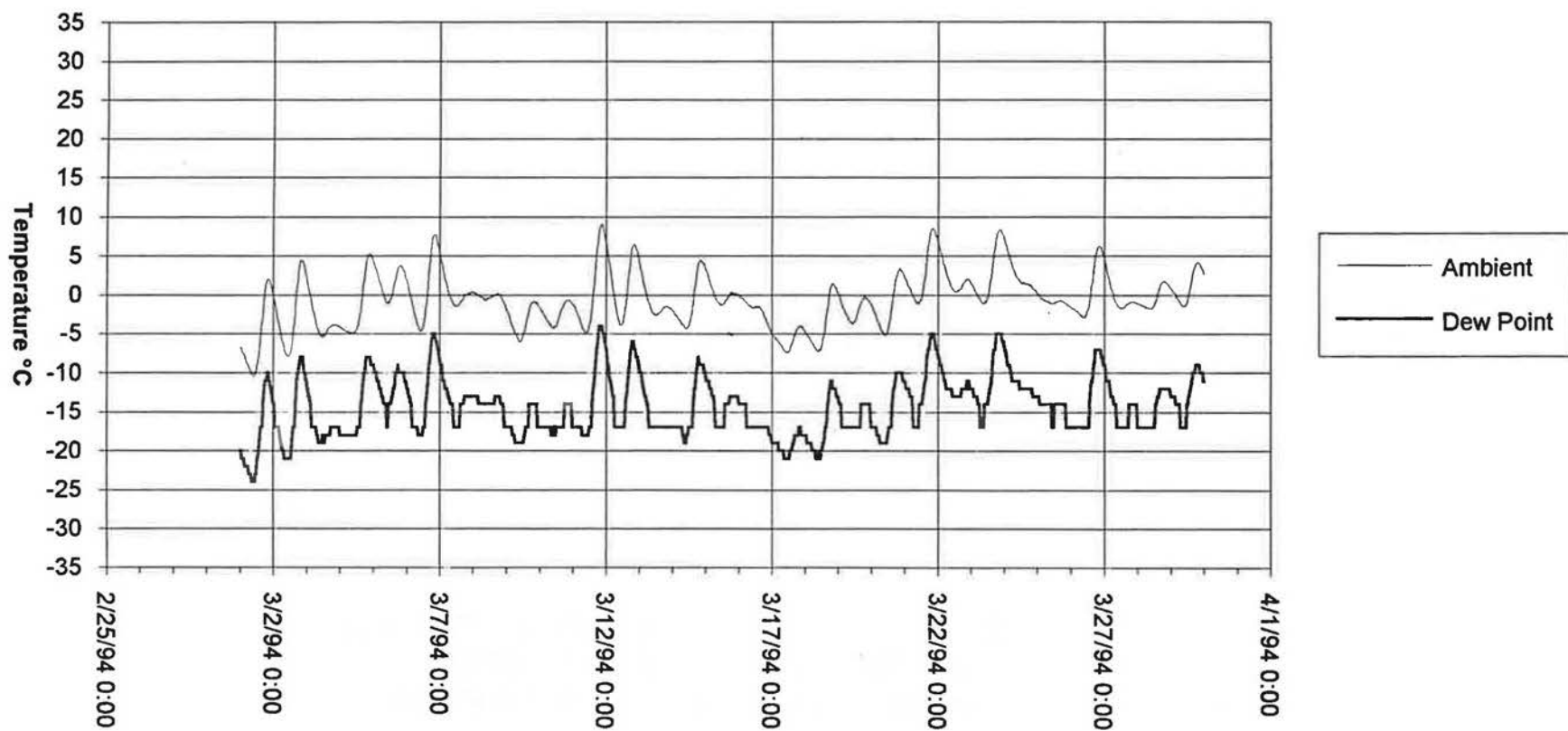

**APCHQ House - EASE Construction Details  
Southwest Wall - Brick Cladding  
In Wall Ambient/Dew Point Temperatures - April 1994**

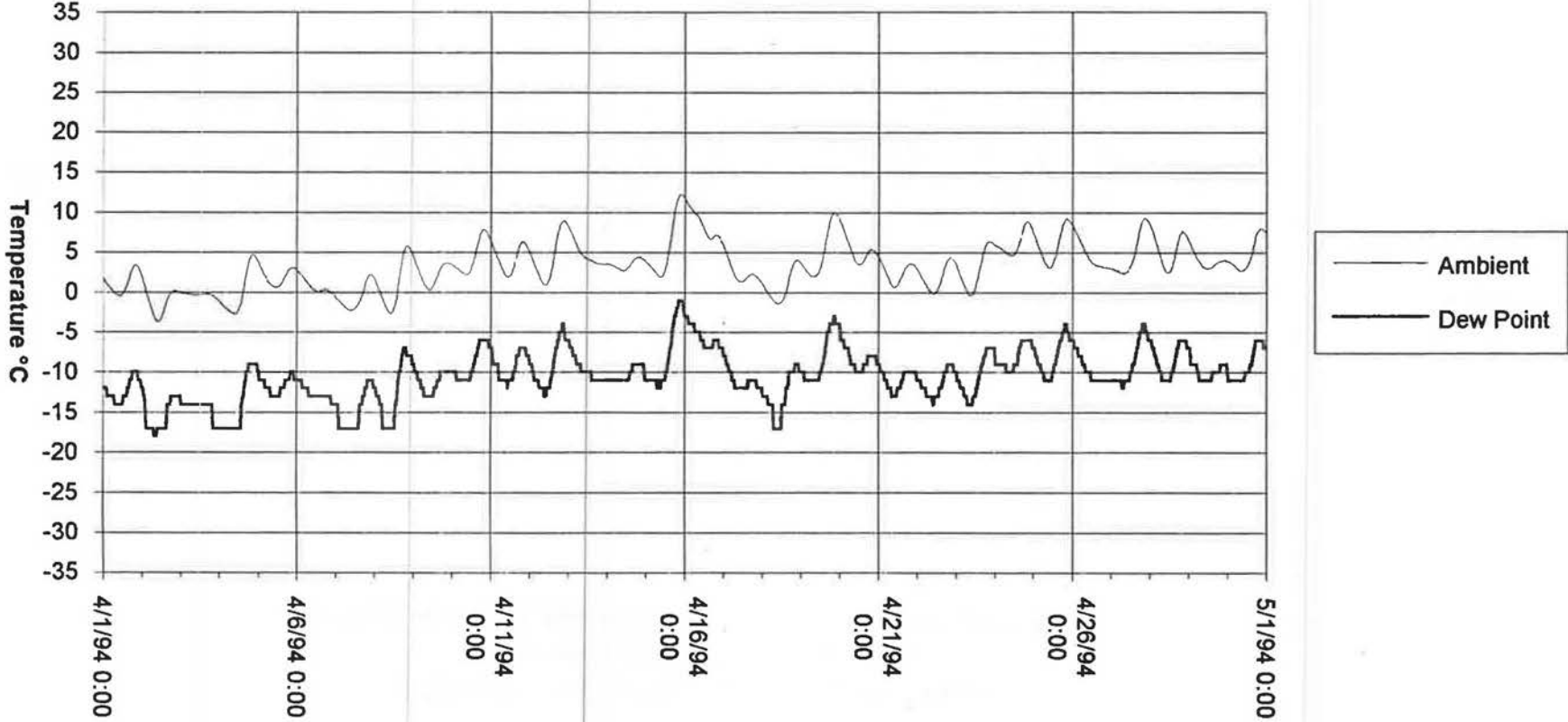



**APCHQ House - EASE Construction Details  
Southwest Wall - Brick Cladding  
In Wall Ambient/Dew Point Temperatures - May 1994**

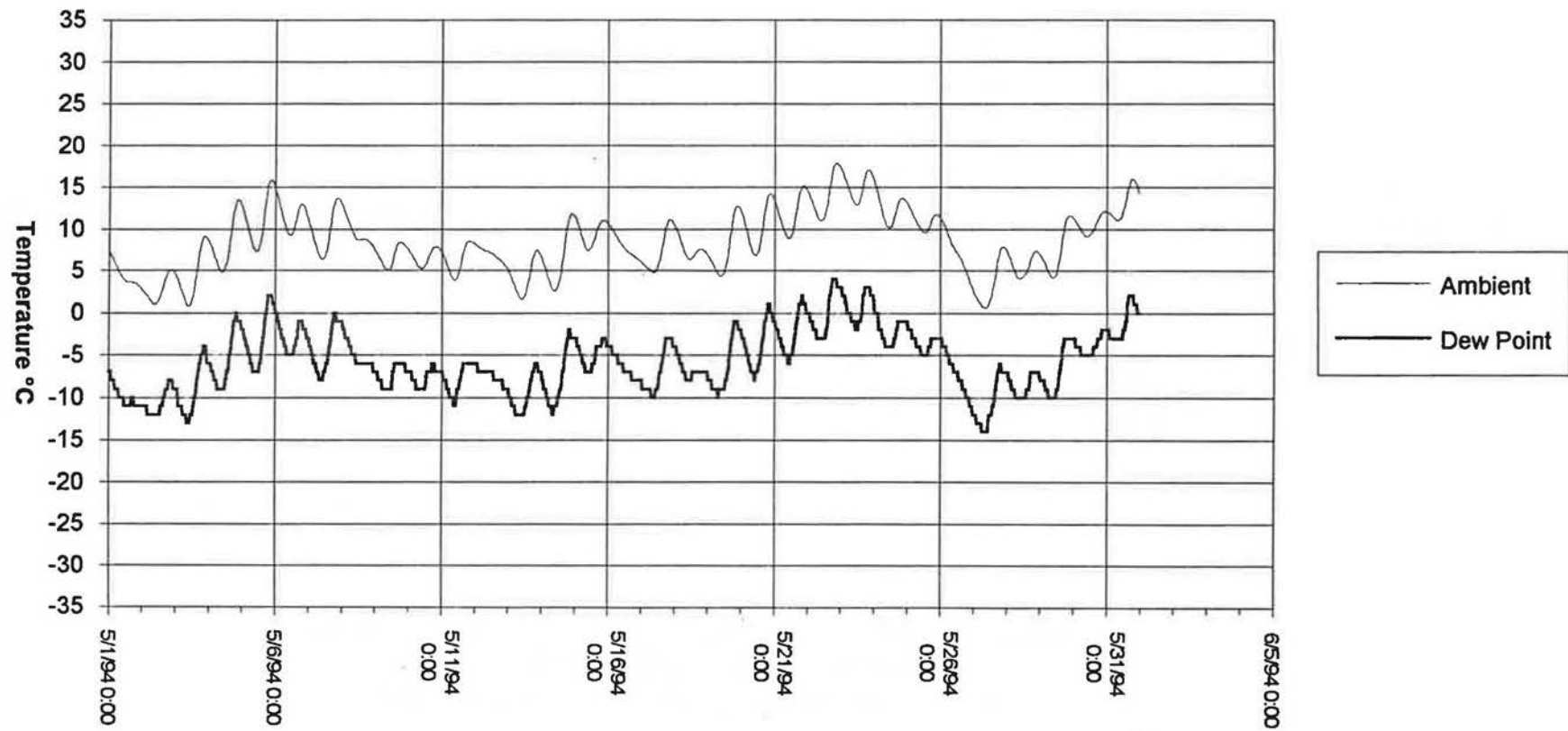

**APCHQ House - EASE Construction Details  
Southwest Wall - Brick Cladding  
In Wall Ambient/Dew Point Temperatures - June 1994**

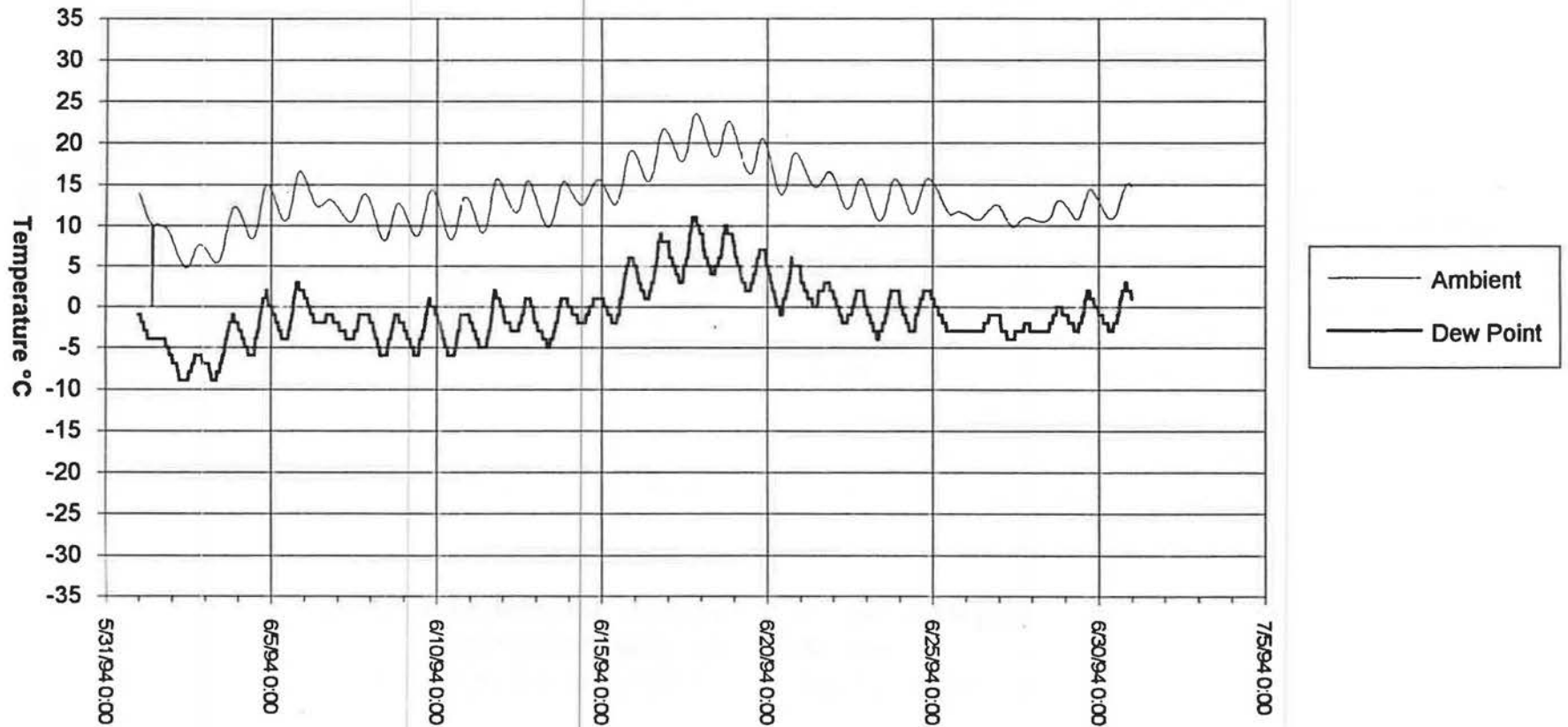

APCHQ House - EASE Construction Details  
Attic - Mean Pressure Differences  
October 1993

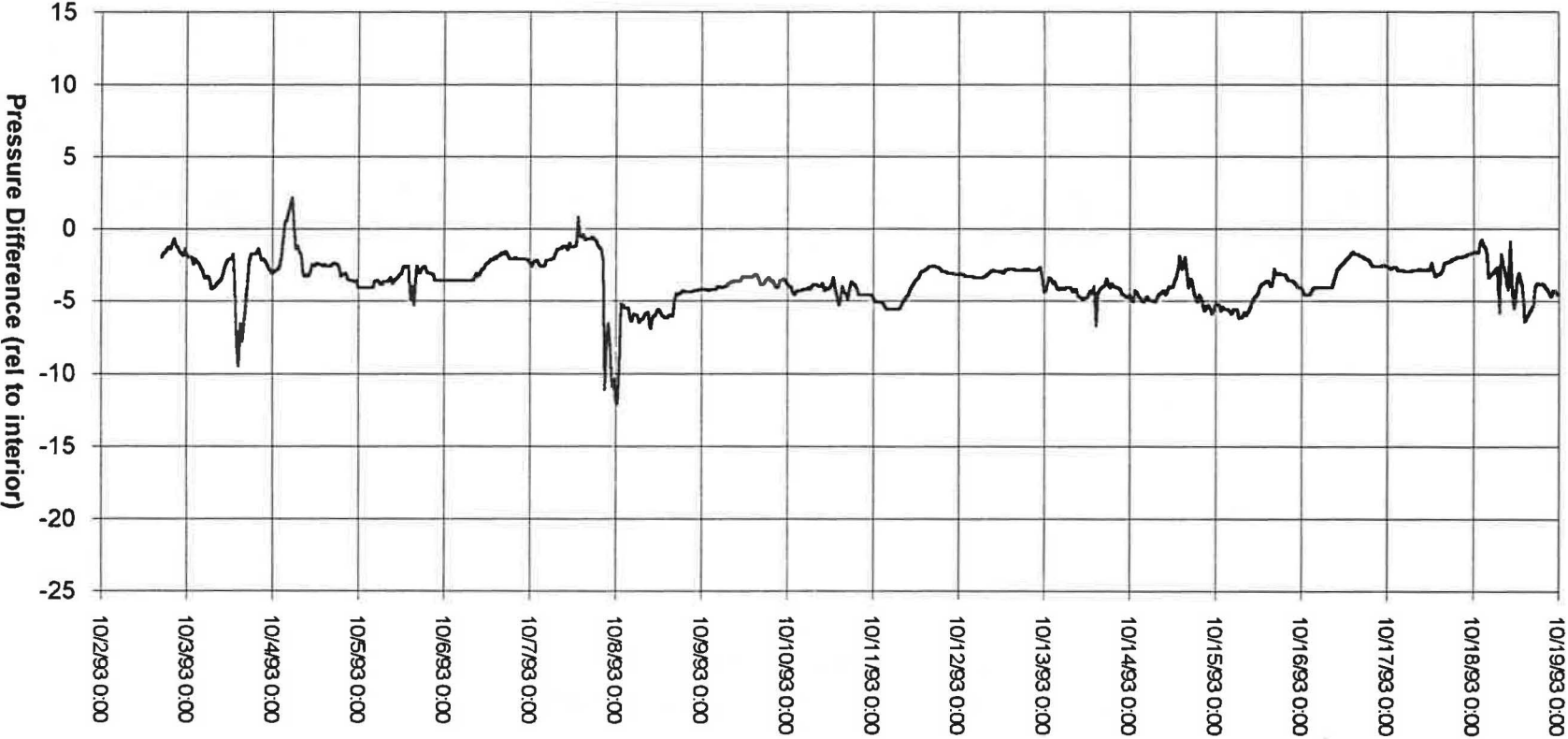

**APCHQ House - EASE Construction Details  
Attic - Mean Pressure Differences  
March 1994**

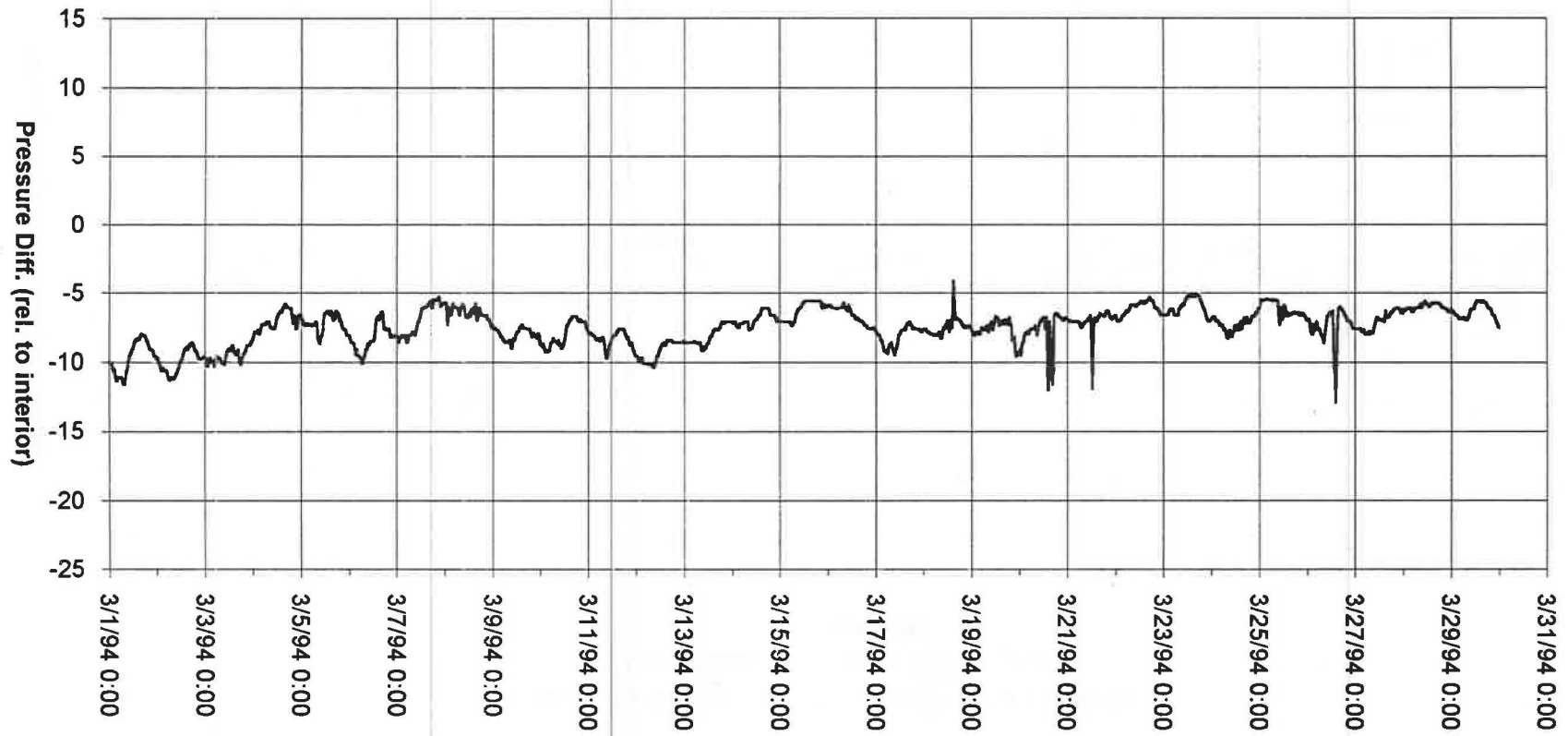

APCHQ House - EASE Construction Details  
Attic - Mean Pressure Differences  
April 1994

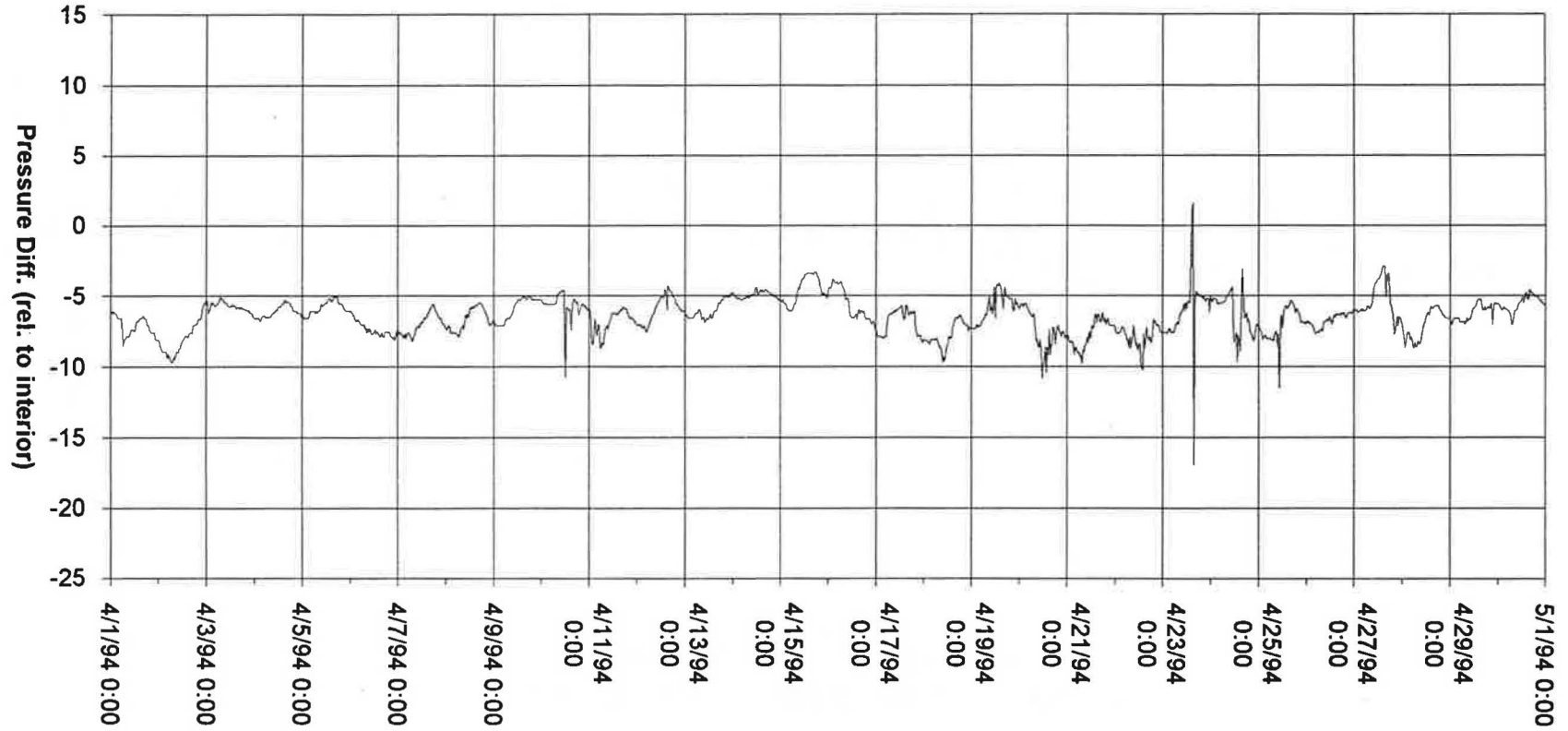

APCHQ House - EASE Construction Details  
Attic - Mean Pressure Differences  
May 1994

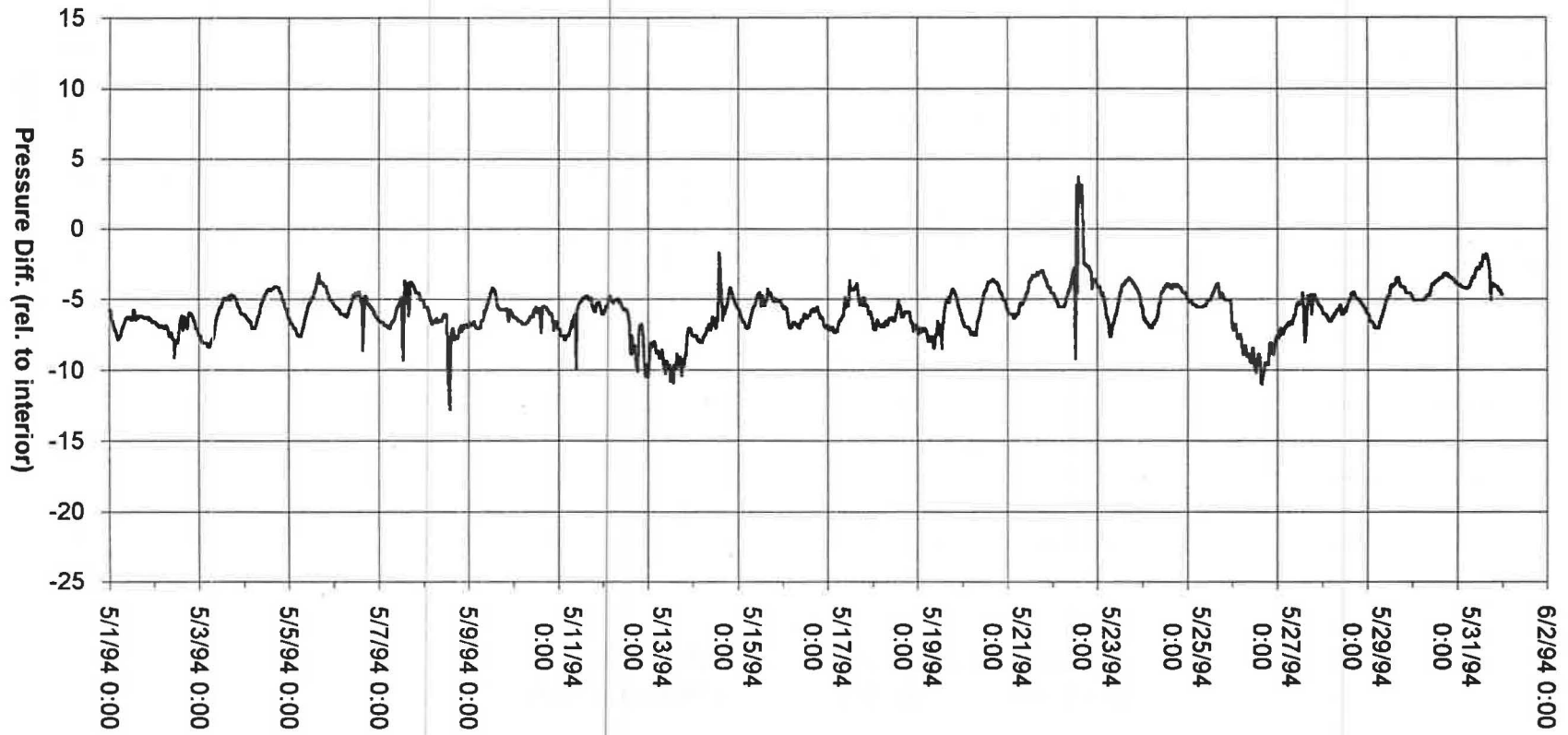

APCHQ House - EASE Construction Details  
Attic - Mean Pressure Differences  
June 1994

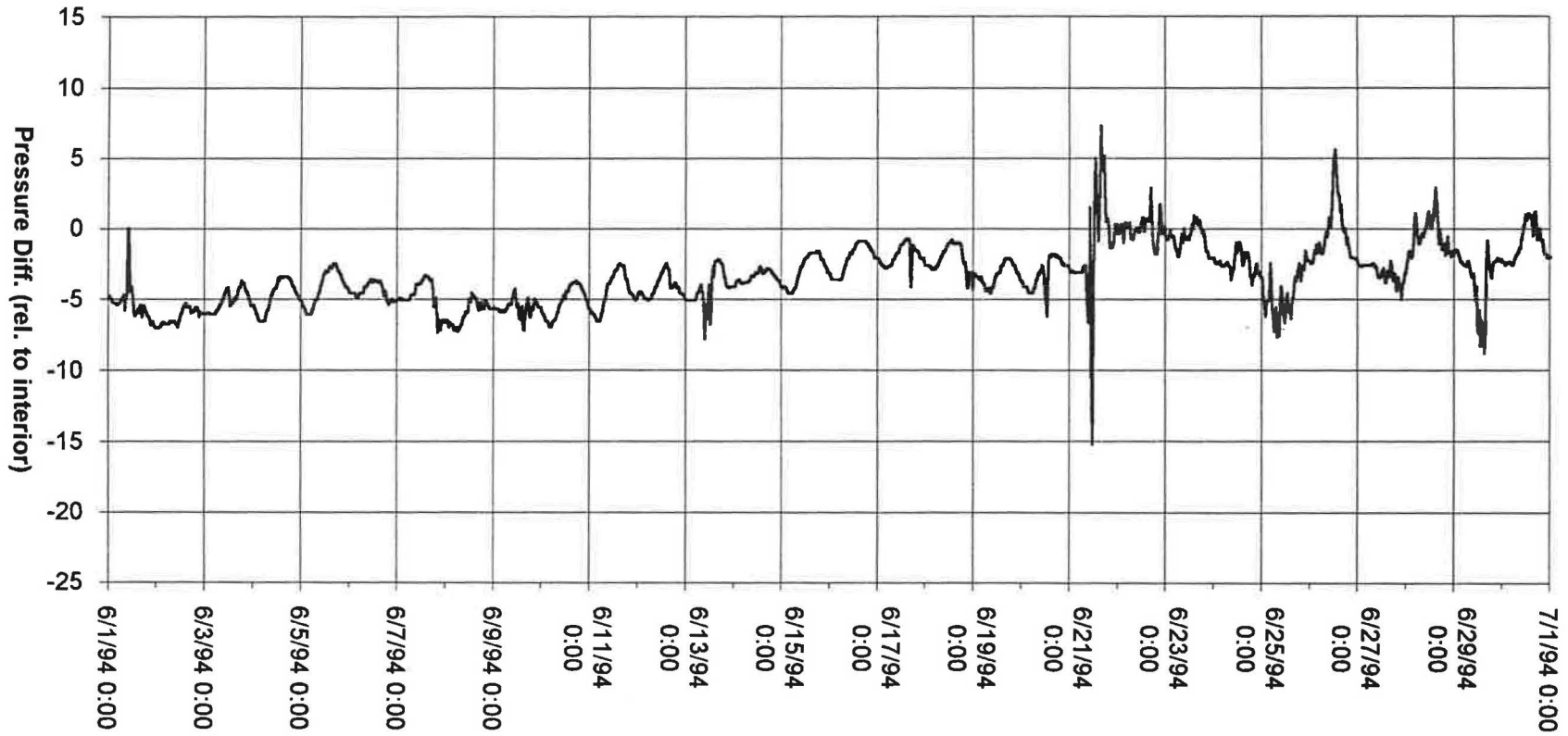





**APPENDIX C**  
**Construction Details**



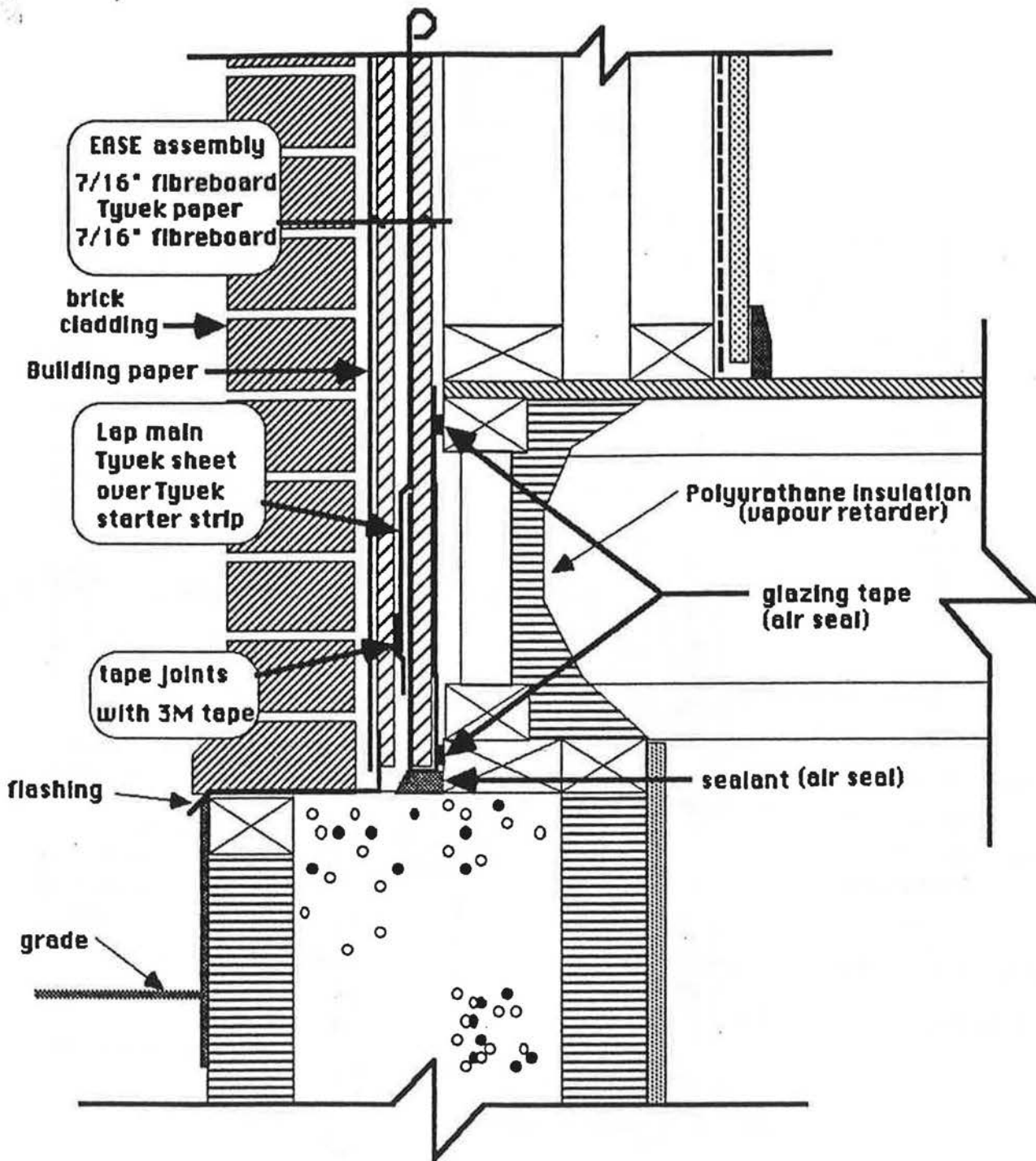

**APCHQ**

**EASE Air Barrier System**

**FOUNDATION -SILL PLATE-HEADER Detail**

<b>1</b>	26 Jan. 1993

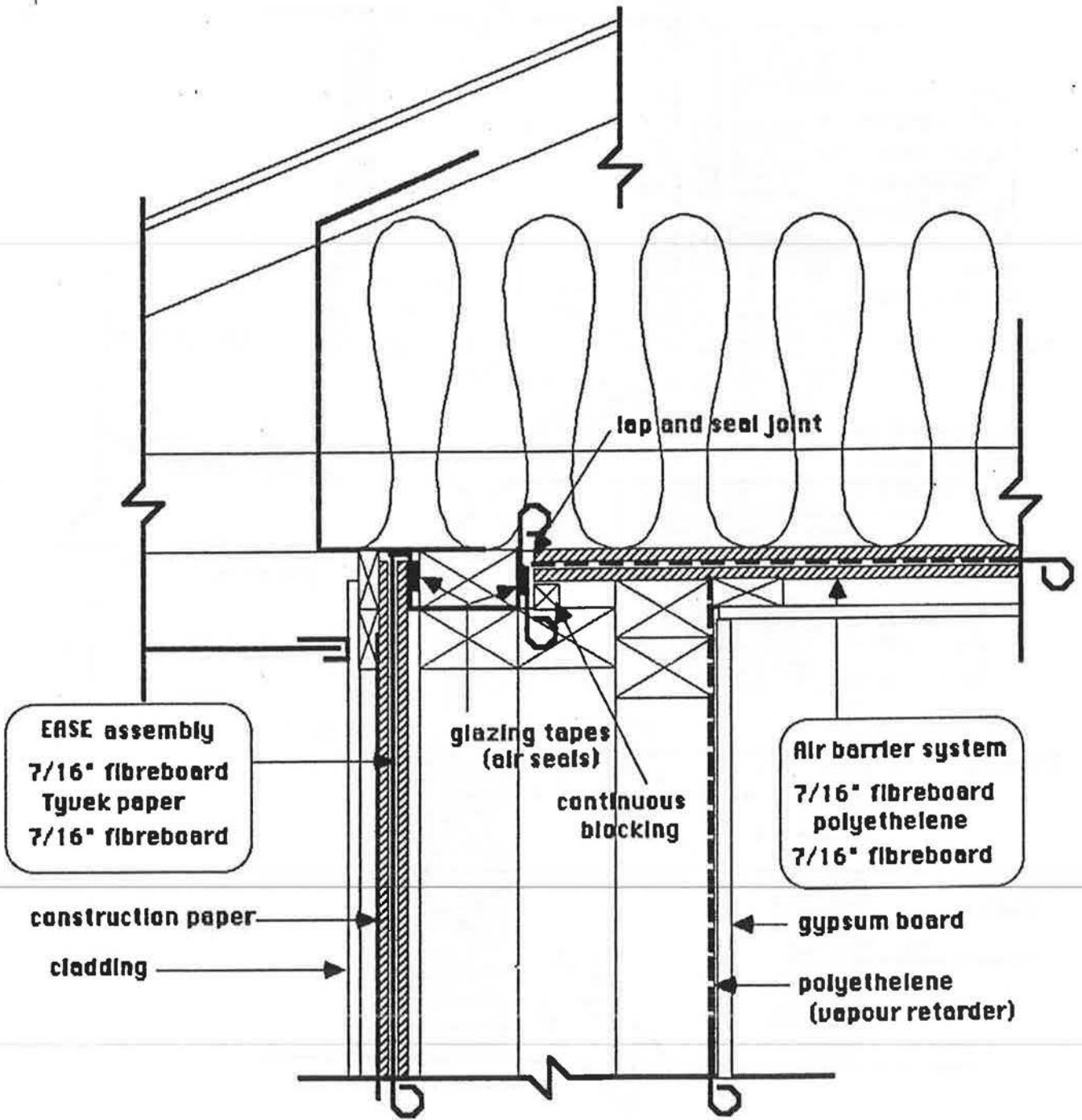

**APCHQ**  
**EASE Air Barrier System**  
**WALL/CEILING CONNECTION DETAIL**

<b>QBE</b>	
<b>2</b>	26 Jan. 1993

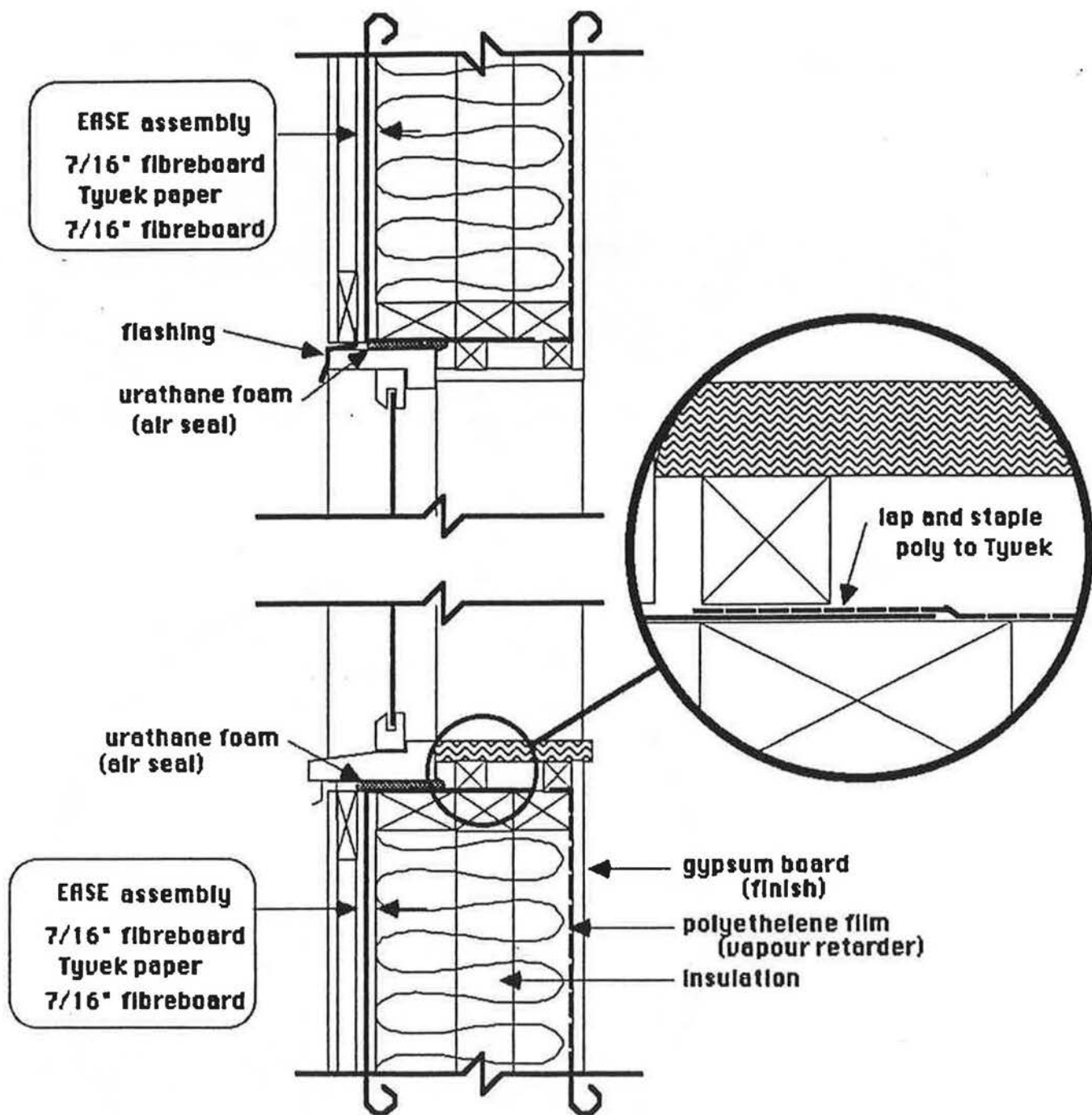

**APCHQ**

**EASE Air Barrier System  
 TYPICAL WINDOW DETAIL**

<b>ME</b>	
<b>3</b>	26 Jan. 1993

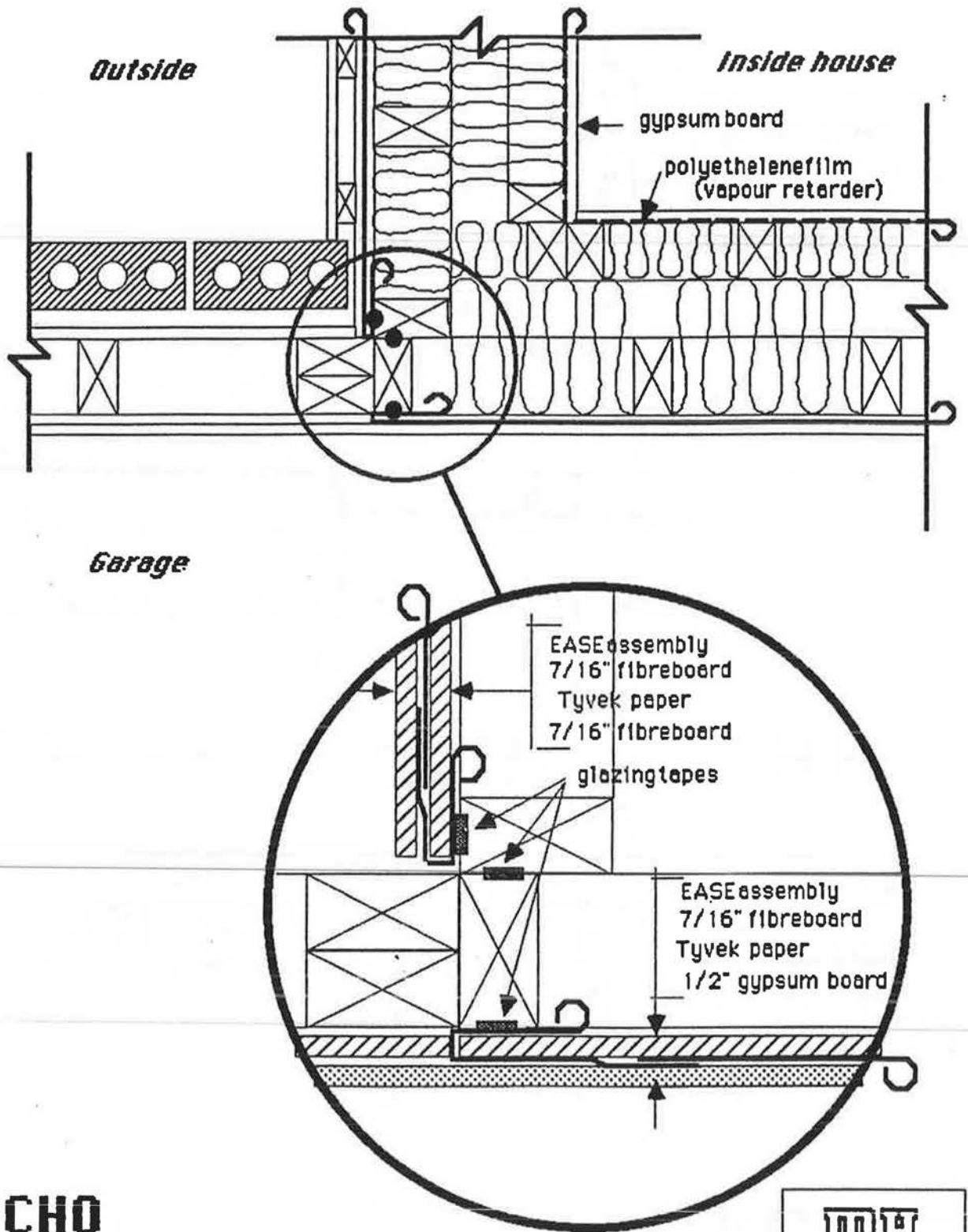

**APCHQ**

**EASE Air Barrier System**

**PLAN DETAIL - GARAGE/HOUSE CORNER**

<b>4</b>	26 Jan. 1993

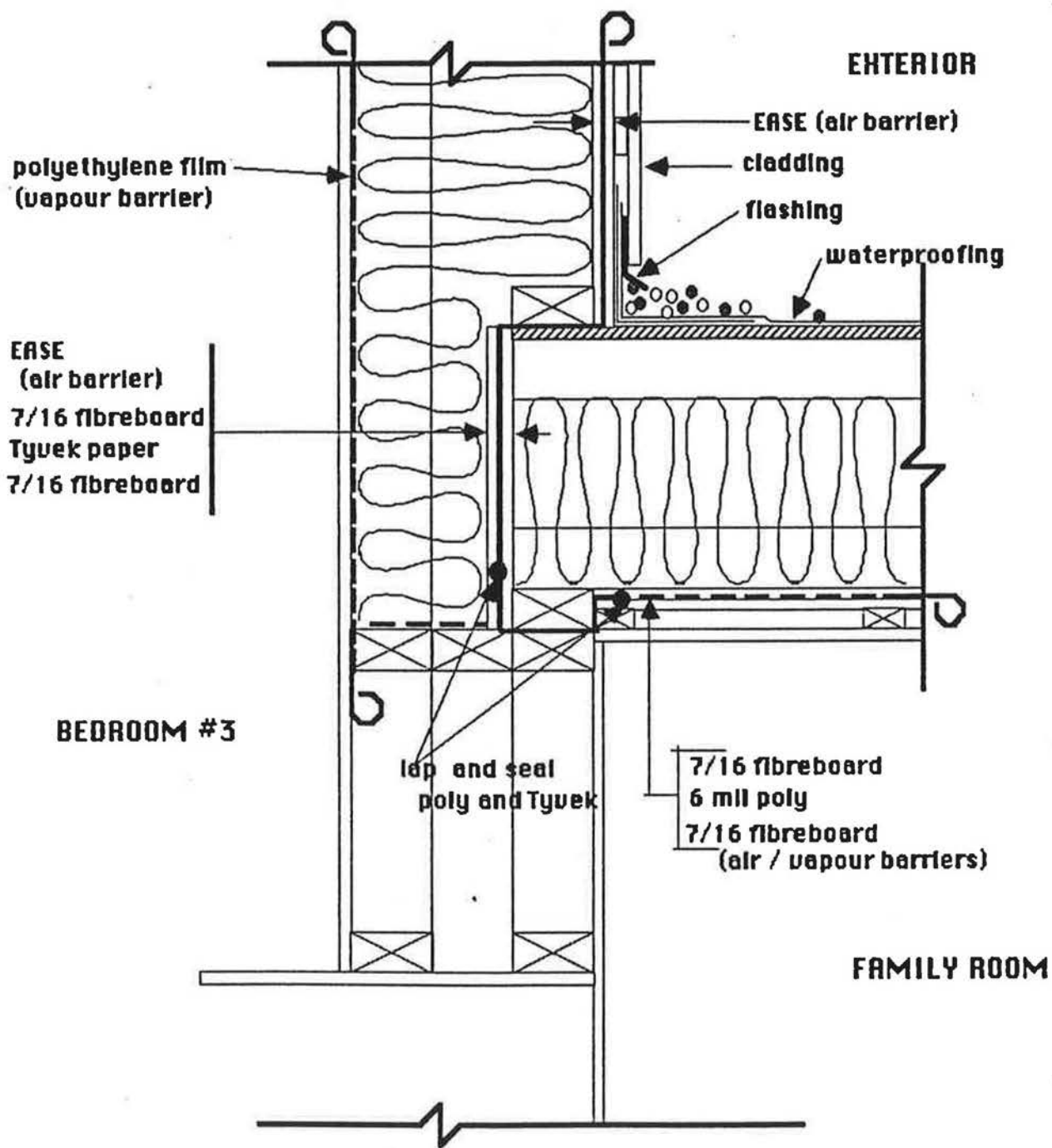

**APCHQ**

**EASE Air Barrier System**

**SECTION DETAIL - EXTERIOR WALL/ROOF**

<b>QBE</b>	
<b>5</b>	4 Feb. 1993





**APPENDIX D**  
**Evaluation of Data by Others**



**TEST D'INFILTROMETRIE**

**Propriété:** Maison performante (A.P.C.H.Q.)  
rue des Rossignols  
Laval.

**Test réalisé pour le compte de:** TN Conseil

**Date:** 8 avril 1993  
**Heure:** 9:00 heures

**Type de construction:** Unifamiliale Détaché  
**Nombre d'étage:** 2 étages  
**Année de construction:** 1993  
**Type de structure:** Plate-forme à colombage double

**Volume de la propriété:** 692 m<sup>3</sup>

**Test d'infiltrométrie**

Pression obtenue de la maison (Pa)	Pression ventilateur (Pa)	Anneau utilisé (Aucun, A, B)	Débit obtenu (CFM)	Ecart %
50	42	B	179	0,50
45	37	B	168	1.00
40	30	B	151	-1.80
35	25	B	138	-2.10
30	21	B	126	-0.70
25	18	B	117	3.50
20	13	B	99	1.90
15	8	B	77	-3.6
10	—	---	---	---

Nombre de changement d'air @ 50 Pa. 0.92

Ela: 20.02 po<sup>2</sup>  
EQLA: 38.11 po<sup>2</sup>

**Remarque sur le test:**

Maison en construction, sans aucun fini intérieur. L'enveloppe extérieure composée d'un carton fibre 12 mm, Tyvek scellé, carton fibre 12 mm, structure de bois. Les solives de bordures et le périmètre des ouvertures ont été scellés avec de l'uréthane giclé. Au plafond, un coupe-vapeur est recouvert d'un carton fibre 12 mm du côté intérieur. Le puisard avait été scellé à l'aide d'un couvercle en P.V.C., pour la durée du test. Maison extrêmement performante aux infiltrations et exfiltrations.



**Sylvain Beausoleil**  
Technicien

**Pierre Collette et Alain Duval**  
Architectes

**TEST D'INFILTROMETRIE**

04 JUIN 1993

**Propriété:** Maison performante (A.P.C.H.Q.)  
rue des Rossignols  
Laval.

**Test réalisé pour le compte de:** TN Conseil

**Date:** 19 mai 1993  
**Heure:** 9:30 heures

**Type de construction:** Unifamiliale Détaché  
**Nombre d'étage:** 2 étages  
**Année de construction:** 1993  
**Type de structure:** Plate-forme à colombage double

**Volume de la propriété:** 598 m<sup>3</sup>

**Test d'infiltrométrie**

Pression obtenue de la maison (Pa)	Pression ventilateur (Pa)	Anneau utilisé (Aucun, A, B)	Débit obtenu (CFM)	Ecart %
50	34	B	161	1.50
45	28	B	146	-0.60
40	23	B	132	-2.10
35	19	B	120	-2.00
30	16	B	110	0.50
25	13	B	99	3.20
20	9	B	82	0.80
15	6	B	67	1.10
10	3	B	47	-4.60

Nombre de changement d'air @ 50 Pa. 0.95

Ela: 15.21 po<sup>2</sup>  
EQLA: 30.66 po<sup>2</sup>

**Remarque sur le test:**

Maison terminée à 80%, seul les finis intérieurs sont à terminer. (Couvre-plancher, peinture etc...), le nombre de changement d'air à 50 Pa est légèrement supérieur au premier test mais il faut considérer que le volume est de 94 m<sup>3</sup> plus petit et que certaines ouvertures dans l'enveloppe extérieure ont été ajoutées, (électricité, plomberie).

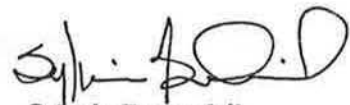

**Sylvain Beausoleil**  
**Technicien**

**Pierre Collette et Alain Duval**  
**Architectes**

```

*****
*
*           Hot2000
*          Version 6.02
*           CANMET
* Energy, Mines and Resources CANADA
*           July 1, 1991
*
*****

```

House Data Filename=C:\H2K\MUYLGEO.HDF

Weather Data is for MONTREAL, QUEBEC

Builder Code = Data Entry by:

Client name: APCHQ - MAISON PERFORMANTE  
 Street address:  
 City: Region:  
 Postal code: Telephone:

\*\*\* GENERAL HOUSE CHARACTERISTICS \*\*\*

House type: Single detached  
 Number of storeys: Two storeys  
 Wall construction: Double stud wall

SOIL TYPE: Normal Conductivity: dry sand, loam, clay, low water table

HOUSE THERMAL MASS LEVEL: (C) Interior wall finish of 100 mm brick,  
 12.5 mm gyproc ceiling, wooden floor  
 → (citerne eau de pluie)

Occupants : 2 Adults for 50.0 % of the time  
 2 Children for 50.0 % of the time

\*\*\* HOUSE TEMPERATURES \*\*\*

Heating Temperatures	Main Floor	= 21.0 C
	Basement	= 20.0 C
Cooling Temperature	TEMP. Swing from 21.0 C	= 3.5 C
	Main Floor + Basement	= 25.0 C

\*\*\* FOUNDATION CONSTRUCTION CHARACTERISTICS \*\*\*

Foundation Construction	Attachment Sides	Insulation Placement
Full Basement	None	Interior

## \*\*\* WINDOW CHARACTERISTICS \*\*\*

Direction	Seq #	Location Code	# of Windows	Type	Window		OverHang Width	Header Height	SHGC
					Width	Height			
					m	m	m	m	
South	P4 1	M1	1	(1) 223224	2.286	2.134	1.829	2.438	.6354
	P4 2	M1	1	(2) 223204	2.286	1.067	1.829	1.372	.6671
	E4 3	M1	1	(2) 223204	1.067	1.372	.396	.305	.6504
Southeast	P5 1	M1	1	(3) 793214	1.676	2.134	.000	.000	.4320
	E6 2	M1	1	(3) 793214	1.676	1.524	.396	.457	.4206
	E5 3	M1	1	(4) 793204	.762	1.372	.396	.305	.4202
East	P5 1	M1	1	(4) 793204	1.829	.457	.000	.000	.3928
	P5 2	M1	1	(4) 793204	.457	.762	.000	.000	.3675
	S1 3	M1	1	(3) 793214	1.829	.457	.000	.000	.3298
North	R6 1	M1	1	(4) 793204	1.829	.457	.000	.000	.3928
	E7 2	M1	1	(3) 793214	.610	1.219	.396	.305	.3493
	E7 3	M1	1	(4) 793204	.610	.610	.396	.914	.3758
Northwest	E8 1	M1	1	(3) 793214	.762	1.433	.396	.457	.3752
Southwest	P3 1	M2	1	(5) 793222	1.829	2.134	1.829	.305	.4225
	R2 2	M1	1	(9) 223204	1.311	2.134	1.219	2.743	.6756
	P1 3	M1	1	(6) 223202	.305	2.134	2.438	2.743	.5452
	E3 4	M1	1	(2) 223204	.762	1.372	.396	.305	.6287
	E2 5	M1	1	(4) 793204	.914	1.372	1.219	.000	.4285
	E1 6	M1	1	(3) 793214	.914	1.372	1.219	.000	.3866

## \*\*\* WINDOW PARAMETER CODES SCHEDULE \*\*\*

Code	Description ( Glazings, Coatings, Fill, Spacer, Type, Frame )
1 223224	Double (DG), Low-E .2 (Hard1), 13 mm Argon, Insulating, Slider with sash, Vinyl
2 223204	Double (DG), Low-E .2 (Hard1), 13 mm Argon, Insulating, Picture, Vinyl
3 793214	DG + 2 films, Heat Mirror 88, 13 mm Argon, Insulating, Hinged, Vinyl
4 793204	DG + 2 films, Heat Mirror 88, 13 mm Argon, Insulating, Picture, Vinyl
5 793222	DG + 2 films, Heat Mirror 88, 13 mm Argon, Insulating, Slider with sash, Wood
6 223202	Double (DG), Low-E .2 (Hard1), 13 mm Argon, Insulating, Picture, Wood

## \*\*\* BUILDING PARAMETERS \*\*\*

Component	Area (m2 )		RSI	Heat Loss MJ	% Annual Heat Loss
	Gross	Net			
-----					
Above Grade Components					
Ceiling					
C1	85.56	85.56	11.45		
TOTAL:	85.56	85.56	11.45	3509.3	5.85



Component	Area (m2 )		RSI	Heat Loss MJ	% Annual Heat Loss	
	Gross	Net				
<b>Main Walls</b>						
M1	168.15	138.18	5.64			
M2	17.37	13.47	5.64			
M3	17.84	15.89	5.64			
TOTAL:	203.36	167.54	5.64	13008.8	21.69	
<b>Doors</b>						
D1	Location: M1	1.95	1.95	1.41		
D2	M3	1.95	1.95	1.41		
TOTAL:		3.90	3.90	1.41	1300.3	2.17
<b>Exposed or overhanging floors</b>						
		10.96		7.92		
		9.29		7.92		
TOTAL:		20.25		7.92	1128.6	1.88
<b>Basement walls above grade</b>						
B1		10.50	10.50	5.64		
B2		5.85	5.85	5.64		
TOTAL:		16.35	16.35	5.64	1281.2	2.14
<b>Full Basement Area</b>						
<b>Upper Basement Walls</b>						
		8.36		5.64		
		10.41		5.64		
		2.60		5.64		
		2.60		5.64		
TOTAL:		23.97		5.64	1592.1	2.66
<b>Lower basement walls</b>						
		16.72		5.64		
		10.41		5.64		
		2.60		5.64		
		2.60		5.64		
TOTAL:		32.33		5.64	2075.7	3.46
<b>Perimeter area</b>						
		29.26		1.76		
TOTAL:		29.26		1.76	3570.5	5.95
<b>Centre area</b>						
		40.97		1.76		
TOTAL:		40.97		1.76	3427.7	5.72

## WINDOWS

Orientation Location	Number	Type (Code)	Total Area(m2 )	RSI Window	(Shutter)	Heat Loss MJ	% Annual Heat Loss
South							
M1	1	223224	4.88	.50	(.35)		
M1	1	223204	2.44	.54	(.35)		
M1	1	223204	1.46	.53	(.00)		
TOTAL:			8.78	.51	(.27)	6488.0	10.82
Southeast							
M1	1	793214	3.58	1.04			
M1	1	793214	2.55	1.02			
M1	1	793204	1.05	.92			
TOTAL:			7.18	1.01		3320.5	5.54
East							
M1	1	793204	.84	.85			
M1	1	793204	.35	.80			
M1	1	793214	.84	.84			
TOTAL:			2.02	.84		1134.1	1.89
North							
M1	1	793204	.84	.85			
M1	1	793214	.74	.88			
M1	1	793204	.37	.82			
TOTAL:			1.95	.85		1073.9	1.79
Northwest							
M1	1	793214	1.09	.92			
TOTAL:			1.09	.92		555.9	.93
Southwest							
M2	1	793222	3.90	.86			
M1	1	223204	2.80	.54			
M1	1	223202	.65	.49			
M1	1	223204	1.05	.53			
M1	1	793204	1.25	.95			
M1	1	793214	1.25	.94			
TOTAL:			10.90	.69		7378.8	12.31

## Ventilation

House Volume	Air Change	Heat Loss MJ	% Annual Heat Loss
534.57 m3	.43 ACH	9119.0	15.21

## \*\*\* AIR LEAKAGE AND VENTILATION \*\*\*

<u>Building Envelope Surface Area</u>	=	452.1 m2
Air Tightness Level is Energy tight ( 1.5 ACH @50 Pa.)		
Building Envelope is NOT Sheltered from the Wind.		
Estimated Equivalent Leakage Area	=	288.6 cm2
Normalized Leakage Area	=	.6384 cm2/m2
Estimated Airflow to cause a 5 Pa Pressure Difference	=	18 L/s
Estimated Airflow to cause a 10 Pa Pressure Difference	=	29 L/s
ELA used to calculate Estimated Airflows	=	115.4 cm2

## F-326 VENTILATION REQUIREMENTS:

Kitchen, living, dining:	4 rooms @ 5 L/s	= 20 L/s
Bedrooms:	1 rooms @ 10 L/s	= 10 L/s
Bedrooms:	2 rooms @ 5 L/s	= 10 L/s
Bathrooms:	2 rooms @ 5 L/s	= 10 L/s
Other habitable rooms:	1 rooms @ 5 L/s	= 5 L/s
Basement Rooms:		0 L/s

## \*\*\* EXHAUST FLOW RATES ( L/s ) \*\*\*

	Continuous	Intermittent
Dryer		75.0
Kitchen	.0	70.8
All Bathrooms	.0	.0
All other exhaust devices	.0	.0
Vented central vac.		.0
Largest Intermittent exhaust (other than Dryer)		70.8

Total continuous exhaust flow	.0 L/s
Exhaust Fan Power	.0 watts

F-326 Required continuous ventilation rate	=	55.0 L/s ( .37 ACH)
Average Ventilation Supply Rate ( Balanced )	=	55.0 L/s ( .37 ACH)

Ventilation System:	Heat recovery ventilator (HRV)
Manufacturer:	VENMAR INC.
Model Number:	FLAIR HRV 5585 COMPACT HE+DC

Fan and Preheater Power at .0 C	=	90. Watts
Fan and Preheater Power at -25.0 C	=	100. Watts
PreHeater Capacity:	=	0. Watts
Sensible Heat Recovery Efficiency at .0 C	=	84. %
Sensible Heat Recovery Efficiency at -25.0 C	=	72. %
Total Heat Recovery Efficiency in Cooling mode	=	0. %

Low Temperature Ventilation Reduction	=	7. %
Low Temperature Ventilation Reduction: Airflow Adjustment	=	1 L/s ( 1.4 %)

NO Vented combustion appliance specified

Gross Air Leakage and Ventilation Energy Load	=	36886.1 MJ
Seasonal Heat Recovery Ventilator Efficiency	=	82.0 %
Estimated Ventilation Electrical Load: Heating Hours	=	2578.9 MJ
Estimated Ventilation Electrical Load: Non-Heating Hours	=	270.4 MJ
Net Air Leakage and Ventilation Energy Load	=	10408.5 MJ

\*\*\* SPACE HEATING SYSTEM \*\*\*

PRIMARY Space Heating Fuel	:	Electricity
Space Heating Equipment	:	Ground Source Heat Pump
Manufacturer	:	TRI-THERMI
Model	:	ATV028
Capacity at 8.3 C	=	6.1 kW
COP at 8.3 C	=	3.60
Crankcase Heater Power	=	60.0 watts
Heat Pump Temperature Cut-Off	:	Unrestricted Cut-Off

SECONDARY Heating Fuel	:	Electricity
Equipment	:	Forced air furnace
Manufacturer	:	
Model	:	
Output Capacity	=	kW
Steady State Efficiency	=	100.0 %
Fan Mode : Auto		Fan Power 187. watts

\*\*\* ANNUAL SPACE HEATING SUMMARY \*\*\*

Design Heat Loss at -23.0 C	=	15.55 Watts/m3	=	8311. Watts
Gross Space Heating Load	=	59964. MJ		
Sensible Daily Heat Gain From Occupants	=	2.40 kWh/day		
Usable Internal Gains	=	20107. MJ		
Usable Internal Gains Fraction	=	33.5 %		
Usable Solar Gains	=	23845. MJ		
Usable Solar Gains Fraction	=	39.8 %		
Ventilation Equipment Electrical Contribution	=	1289. MJ		
Auxiliary Energy Required	=	16012. MJ		
Space Heating System Load	=	16012. MJ		
Heat Pump and Furnace Annual COP	=	2.780		
Heat Pump Annual Energy Consumption	=	5050. MJ		
Furnace/Boiler Annual Energy Consumption	=	226. MJ		
Annual Space Heating Energy Consumption	=	5276. MJ		

## \*\*\* AIR CONDITIONING SYSTEM \*\*\*

System Type : Conventional A/C  
 Manufacturer: WATERFURNACE  
 Model: W

Capacity:	5829. Watts	Rated COP:	4.688
Sensible Heat Ratio :	.700		
Indoor Fan Flow Rate:	351.2 L/s	Fan Power (watts)	272.2
Ventilator Flow Rate:	.0 L/s	Crankcase Heater Power (watts):	60.0
Fraction of windows Openable :	.000		
Fraction of internal gains released in basement :	.300		

Economizer control : Not selected Indoor Fan Operation: Auto  
 Air Conditioner is integrated with the Heating System

## \*\*\* ANNUAL SPACE COOLING SUMMARY \*\*\*

Design Cooling Load for Jul at 30.0 C	=	7877. Watts
Design Sensible Heat Ratio	=	.769
Estimated Annual Space Cooling Energy	=	1104. kWh
Seasonal COP ( May to Oct )	=	4.887

## \*\*\* DOMESTIC WATER HEATING SYSTEM \*\*\*

PRIMARY Water Heating Fuel : Solar  
 Water Heating Equipment : Solar collector system

Manufacturer	:	FOURNELLE ENERGIES TECHNOLOGIE
Model	:	FET
CSIA Solar Collector Rating	=	10500. MJ/year

SECONDARY Water Heating Fuel: Electricity  
 Water Heating Equipment : Electric tank

Manufacturer	:	
Model	:	
Tank Capacity	=	181.8 Litres
Seasonal Efficiency	=	93.0 %

## \*\*\* ANNUAL DOMESTIC WATER HEATING SUMMARY \*\*\*

Daily Hot Water Consumption	=	236.4 Litres /day
Estimated Domestic Water Heating Load	=	17160. MJ
Solar Domestic Water Heating System Contribution	=	9210. MJ
Domestic Water Heating Energy Consumption	=	8549. MJ

## \*\*\* LIGHTING AND APPLIANCES SUMMARY \*\*\*

Total Electrical Load	=	11.3 kWh/day
Average External Electrical Load	=	.5 kWh/day
Total Annual Energy Consumption	=	4117. kWh

## \*\*\* FAN OPERATION SUMMARY (kWh) \*\*\*

Hours	HRV/Exhaust Fans	Space Heating	Space Cooling
Heating	716.4	134.4	.0
Neither	1.9	.0	.0
Cooling	73.2	.0	288.0
Total	791.5	134.4	288.0

## \*\*\* R-2000 HOME PROGRAM ENERGY CONSUMPTION SUMMARY REPORT \*\*\*

Estimated Annual Space Heating Energy Consumption	=	5276. MJ	=	1465.6 kWh
Ventilator Electrical Consumption: Heating Hours	=	2579. MJ	=	716.4 kWh
Estimated Annual DHW Heating Energy Consumption	=	8549. MJ	=	2374.6 kWh
ESTIMATED ANNUAL SPACE + DHW ENERGY CONSUMPTION	=	16404. MJ	=	4556.5 kWh
ANNUAL R-2000 SPACE + DHW ENERGY CONSUMPTION TARGET	=	53761. MJ	=	14933.5 kWh
Estimated Annual Base Electrical Energy Consumption	=	14822. MJ	=	4117.2 kWh
Ventilator Electrical Consumption: Non Heating Hours	=	270. MJ	=	75.1 kWh

## \*\*\* ESTIMATED ANNUAL FUEL CONSUMPTION SUMMARY \*\*\*

Fuel	Space Heating	Space Cooling	DHW Heating	Appliances	Total
Electricity (kWh)	2316.3	1104.5	2374.6	4119.1	9914.5

## \*\*\* MONTHLY ENERGY PROFILE \*\*\*

Month	Energy Load MJ	Internal Gains MJ	Solar Gains MJ	Aux. Energy MJ	HRV Eff. %
Jan	10537.6	2027.3	3594.4	4915.9	81.8
Feb	9133.6	1831.1	4134.3	3168.2	82.5
Mar	7888.8	2027.3	4552.9	1308.6	83.9
Apr	5119.5	1961.9	2903.7	253.9	83.0
May	2974.8	1922.2	1052.7	.0	80.4
Jun	1296.5	1178.6	117.9	.0	72.8
Jul	628.0	620.9	7.1	.0	67.7
Aug	909.7	876.5	33.1	.0	71.3
Sep	2141.0	1646.9	494.1	.0	78.6
Oct	4059.6	2025.2	2034.4	.0	82.2
Nov	6001.1	1961.9	2240.4	1798.9	83.7
Dec	9274.0	2027.3	2680.4	4566.4	82.6
Ann	59964.	20107.	23845.	16012.	82.0

## \*\*\* SPACE HEATING SYSTEM PERFORMANCE \*\*\*

Month	Space Heating Load kWh	Furnace Input kWh	Pilot Light kWh	Indoor Fans kWh	Heat Pump Input kWh	Total Input kWh	System Cop
Jan	1365.5	25.4	.0	41.1	413.4	479.9	2.845
Feb	880.1	10.6	.0	30.1	292.4	333.1	2.642
Mar	363.5	3.6	.0	13.6	140.2	157.4	2.309
Apr	70.5	.9	.0	2.7	42.2	45.8	1.540
May	.0	.0	.0	.0	.0	.0	.000
Jun	.0	.0	.0	.0	.0	.0	.000
Jul	.0	.0	.0	.0	.0	.0	.000
Aug	.0	.0	.0	.0	.0	.0	.000
Sep	.0	.0	.0	.0	.0	.0	.000
Oct	.0	.0	.0	.0	.0	.0	.000
Nov	499.7	3.4	.0	12.6	148.6	164.6	3.035
Dec	1268.4	18.9	.0	34.2	365.9	419.1	3.027
Ann	4447.8	62.8	.0	134.4	1402.7	1599.9	2.780





# EMPTIED

Envelope Moisture Performance Through Infiltration, Exfiltration and Diffusion  
Handegord and Company Incorporated <sup>developed by</sup> & Trow Consulting Engineers  
<sup>for</sup>  
Canada Mortgage and Housing Corporation

## DISCLAIMER

THE USER OF THIS COMPUTER PROGRAM SHALL DO SO AT HIS, HER, OR ITS OWN RISK AND  
NEITHER THE AUTHORS NOR C.M.H.C. SHALL BE LIABLE TO THE USER FOR ANY DAMAGE OR  
LOSS WHATSOEVER, INCLUDING LOSS OF PROFIT, LOSS OF SAVINGS, OR OTHER  
INCIDENTAL OR CONSEQUENTIAL LOSS THAT MAY BE SUSTAINED BY THE USER ARISING  
OUT OF THE USE OR INABILITY TO USE THE COMPUTER PROGRAM  
If you accept this responsibility press <ENTER> to continue  
If not press <ESC> to quit EMPTIED

## Wall Assembly Section

Wall EASEII

Condensation plane number 1 is plane 5

Condensation plane number 2 is plane 10

Leakage Area = 0.000000 cm<sup>2</sup>/m<sup>2</sup>

Temp/RH File =

Max Absorb = 800 gm/m<sup>2</sup>

Max Absorb = 14000 gm/m<sup>2</sup>

1 INTERIOR AIR FILM	RSI	.12
2 GYPSUM BOARD 13MM	RSI	.08
3 POLYETHYLENE - .10 MM	RSI	0
4 MINERAL WOOL 90 MM	RSI	2
5 MINERAL WOOL 90 MM	RSI	2
6 FIBERBOARD 12MM	RSI	.24
7 TYVEK	RSI	0
8 FIBERBOARD 12MM	RSI	.24
9 SHEATHING PAPER	RSI	.01
10 AIR SPACE VERTICAL 25MM	RSI	.17
11 BRICK	RSI	.08
12 EXTERIOR AIR FILM WINTER	RSI	.029

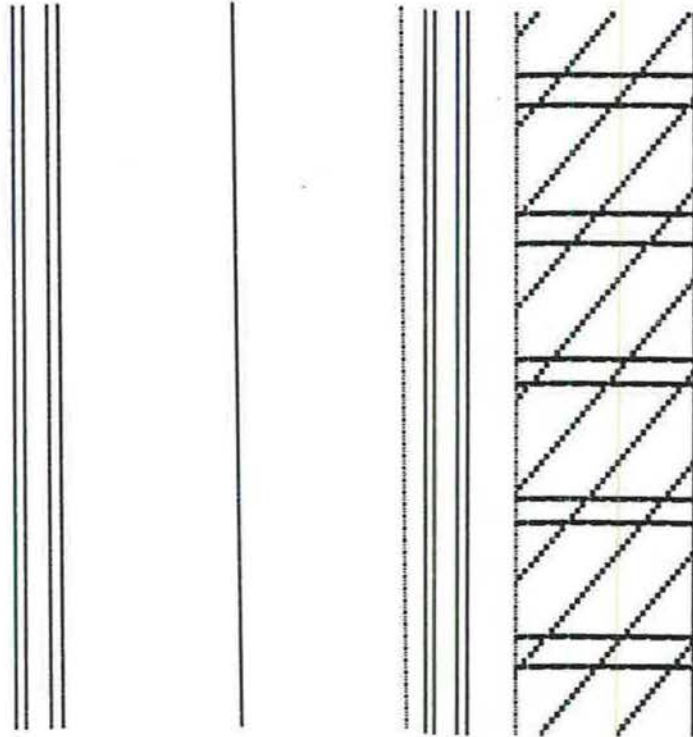

Hit (ESC) to Return

Data File in Use is MONHO.DYR

Mons	Int Temp	Int Hum
Jan	23	30
Feb	23	30
Mar	23	30
Apr	23	30
May	23	30
Jun	23	30
Jul	23	30
Aug	23	30
Sep	23	30
Oct	23	30
Nov	23	30
Dec	23	30

< Exit >

Wall Assembly Int/Ext Conditions Materials Output Run Program

Analysis Data

|||h

Leakage area,  $\text{cm}^2/\text{m}^2$  = [0.57 ]  
Number of month to begin simulation = [1 ]  
Number of years to run simulation = [1 ]  
Use monthly average temperature (y/n) [N ]  
Superimpose pressure differential (Pa) [0 ]  
Disk drive containing bin data files = [a:  
Interior temperature and relative humidity file = Latest Input ]

< Exit >

Wall Assembly Int/Ext Conditions Materials Output Run Program

YEAR 1  
Wall type = EASEII

MON	Plane 1 - kg/m <sup>2</sup>				Plane 2 - kg/m <sup>2</sup>			
	Conden	Evap	Drain	Absorb	Conden	Evap	Drain	Absorb
Jan	0.5004	0.1572	0.0000	0.3433	0.1768	0.0007	0.0000	0.1761
Feb	0.4260	0.1461	0.0000	0.6232	0.2872	0.0000	0.0000	0.4633
Mar	0.1812	0.2561	0.0000	0.5484	0.3227	0.0013	0.0000	0.7847
Apr	0.0075	0.4244	0.0000	0.1315	0.2507	0.0126	0.0000	1.0228
May	0.0022	0.5781	0.0000	0.0000	0.1581	0.0486	0.0000	1.1322
Jun	0.0044	0.5420	0.0000	0.0000	0.0000	0.4393	0.0000	0.6929
Jul	0.0064	0.4795	0.0000	0.0000	0.0000	0.4391	0.0000	0.2538
Aug	0.0027	0.5395	0.0000	0.0000	0.0000	0.4430	0.0000	0.0000
Sep	0.0033	0.5708	0.0000	0.0000	0.0115	0.2914	0.0000	0.0000
Oct	0.0017	0.5716	0.0000	0.0000	0.0170	0.2323	0.0000	0.0000
Nov	0.0538	0.3487	0.0000	0.0000	0.0851	0.0825	0.0000	0.0026
Dec	0.3171	0.1744	0.0000	0.1427	0.1831	0.0211	0.0000	0.1647

Output for MONTREAL, QUEBEC  
interior temp = Latest Input  
interior dewpoint = Latest Input  
leakage area = 0.57000 cm<sup>2</sup>/m<sup>2</sup>

Plane1 = FIBERBOARD 12MM  
Plane2 = BRICK  
Max absorb plane1 = 0.80  
Max absorb plane2 = 14.00

< Exit > <Condensation Breakdown> <Next Year> <Year One> <Graphs>

Wall Assembly Int/Ext Conditions Materials Output Run Program  
 CONDENSATION BREAKDOWN - AIR LEAKAGE vs VAPOUR DIFFUSION  
 Condensation Breakdown applies to all years

Wall type = EASEII

MON	Plane 1 - kg/m <sup>2</sup>			Plane 2 - kg/m <sup>2</sup>						
	Air Lkge	Diffusion	Total	HAFZ	HBFZ	Air Lkge	Diffusion	Total	HAFZ	HBFZ
Jan	0.5004	0.0000	0.5004	278	466	0.1754	0.0014	0.1768	197	547
Feb	0.4260	0.0000	0.4260	246	426	0.1669	0.1203	0.2872	181	491
Mar	0.1812	0.0000	0.1812	523	221	0.1775	0.1452	0.3227	410	334
Apr	0.0075	0.0000	0.0075	720	0	0.1339	0.1168	0.2507	697	233
May	0.0022	0.0000	0.0022	744	0	0.0843	0.0738	0.1581	744	0
Jun	0.0044	0.0000	0.0044	720	0	0.0000	0.0000	0.0000	720	0
Jul	0.0064	0.0000	0.0064	744	0	0.0000	0.0000	0.0000	744	0
Aug	0.0027	0.0000	0.0027	744	0	0.0000	0.0000	0.0000	744	0
Sep	0.0033	0.0000	0.0033	720	0	0.0114	0.0001	0.0115	720	0
Oct	0.0017	0.0000	0.0017	744	0	0.0170	0.0000	0.0170	739	5
Nov	0.0538	0.0000	0.0538	652	68	0.0851	0.0000	0.0851	618	10
Dec	0.3171	0.0000	0.3171	373	371	0.1831	0.0000	0.1831	226	518

< Exit > <Condensation Breakdown> <Next Year> <Year One> <Graphs>

# Plane 1 Condensation Results, g/m<sup>2</sup> For Year 1

Wall EASEII

MONTREAL, QUEBEC

Total Condensation   
Absorbed Condensate   
Drained Condensate 

Temp/RH File = Latest Input  
Leakage Area = 0.570000 cm<sup>2</sup>/m<sup>2</sup>  
Material Max Absorption = 800 g/m<sup>2</sup>

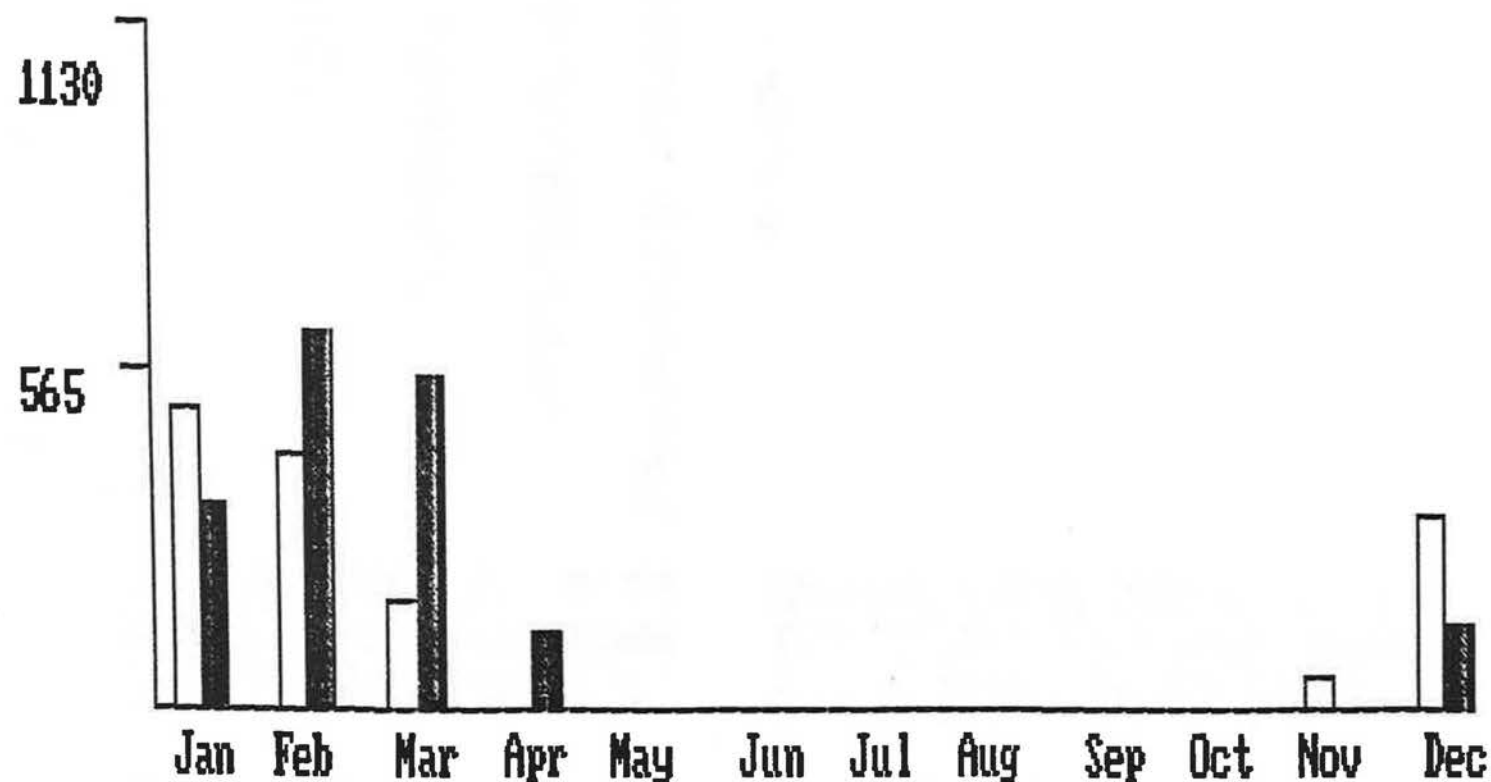

Hit (ESC) to Return, PgDn to see Plane 2, T to Return to Tables

# Plane 2 Condensation Results, g/m<sup>2</sup> For Year 1

Wall EASEII

MONTREAL, QUEBEC

Total Condensation  
Absorbed Condensate  
Drained Condensate



Temp/RH File = Latest Input  
Leakage Area = 0.570000 cm<sup>2</sup>/m<sup>2</sup>  
Material Max Absorption = 14000 g/m<sup>2</sup>

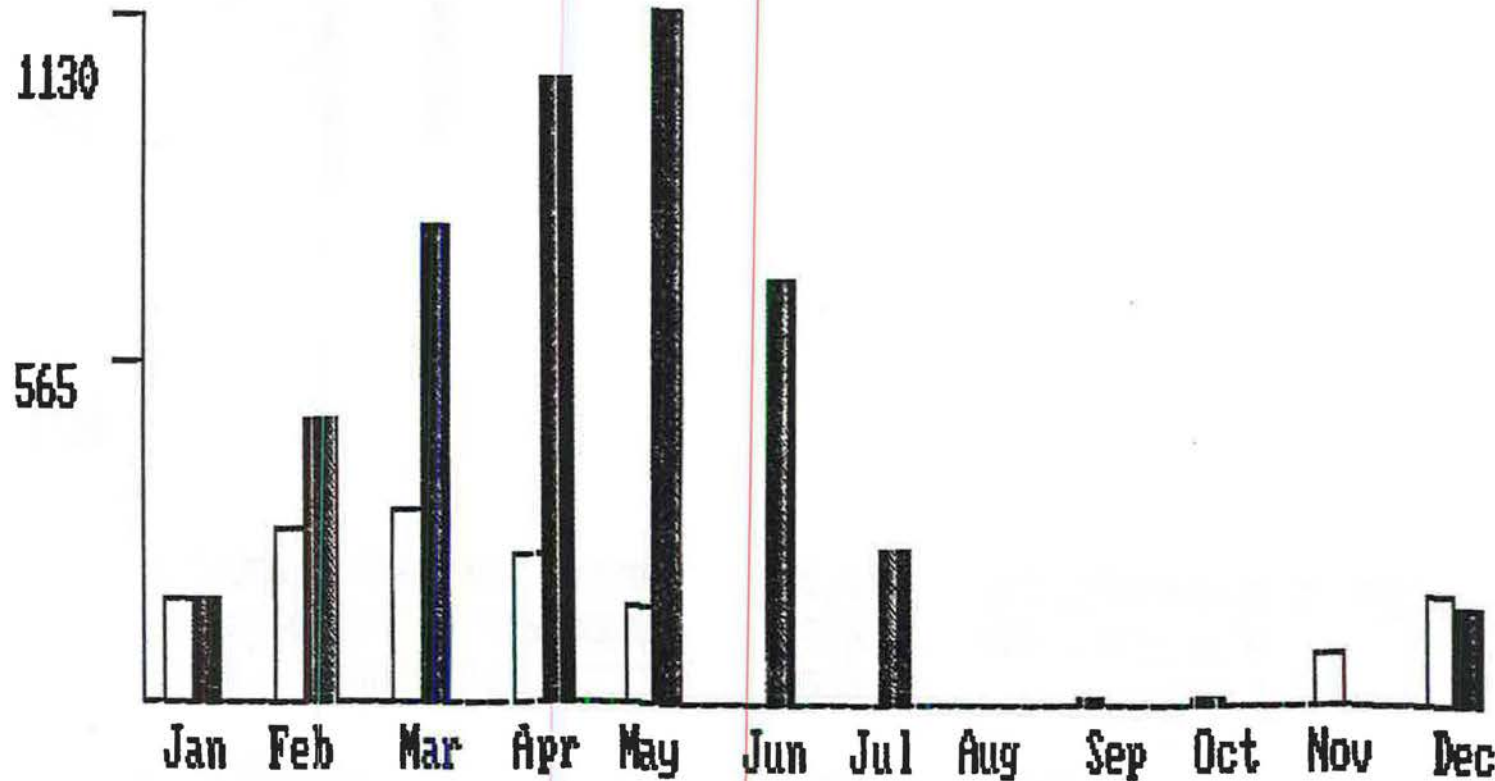

Hit <ESC> to Return, PgUp to see Plane 1, T to Return to Tables