

Increase in Perceived Odor Emissions with Loading of Ventilation Filters

Pertti O. Pasanen¹, Jussi Teijonsalo², Olli Seppänen², Juhani Ruuskanen³, Pentti Kalliokoski¹

Abstract

The development of odor emission rates from EU6 classified glass fiber bag filters was studied in four air-handling units (AHU), and emissions from the same kind of filters with EU3 classified polyester prefilters were studied in two units. The filters were loaded in six AHU in downtown Helsinki. The pressure drop was measured, and the odors of the filters were evaluated by a trained panel under laboratory conditions ($T = 20^{\circ}\text{C}$, face velocity 1.0 m/s) every sixth week. The odor emissions of simultaneous atmospheric dust samples were also studied. The odor emissions of the filters rose during the first three months to a level where every third person would be dissatisfied. The emissions from coarse prefilters were similar to those from the more efficient filters without prefilters, and the emissions of the main filters were significantly lower if used with prefilters. This result indicates that the prefilters effectively protected the fine filters from odor-causing particles. The results of tests made with atmospheric samples agree with this result. Relative odor emissions were the highest in coarse fractions ($> 10.0\ \mu\text{m}$). The pressure drop increased with the particle mass collected on the ventilation filter, but it did not correlate well with the odor emission of the filter. Thus, pressure drop alone is not an adequate criterion for changing supply air filters when hygienic aspects are a concern.

KEY WORDS:

Odor, Ventilation filter, Prefilter, Indoor air quality, Outdoor air particles, Filter change interval

Manuscript received: 20 April 1993
Accepted for publication: 21 November 1993

¹ Department of Environmental Sciences, University of Kuopio, P.O. Box 1627, SF-70211 Kuopio, Finland (Fax: 358-71-163230)

² Laboratory of Heating, Ventilating and Air Conditioning, Helsinki University of Technology

³ Division of Environmental Health, National Public Health Institute

Introduction

Ventilation systems may contribute to indoor air pollution by causing odors. In several studies, decreases in employee comfort or even work-related health symptoms have been reported more frequently in buildings with mechanical ventilation than in buildings with natural ventilation (Finnegan and Pickering, 1987; Jaakkola et al., 1993; Robertson et al., 1990; Ruotsalainen et al., 1990). In some case studies, a ventilation system has acted as a source of fungal spores (e.g., Morey and Williams, 1991) or special odorous substances produced by bacteria. Odors have usually been perceived most strongly on Monday mornings when ventilation is turned on after being off for the weekend (McJilton et al., 1990).

Fanger et al. used an untrained panel of judges and found that ventilation systems are a major odor source in a normal office environment (Fanger et al., 1988). Pejtersen et al. (1989) studied odor emissions from an air-handling unit (AHU). When perceived air quality (PAQ) downstream from each component of the AHU was evaluated by a trained panel, the filter unit was found to be the most odorous component. Bluysen (1993) studied the perceived air quality caused by EU7 classified glass fiber filters using a trained panel. She found that the perceived air quality caused by an unused filter was insignificant compared with the perceived air quality caused by used air filters ranging from 2 to 10 months. The source strength depended strongly on the airflow rate through the used filter. In our previous study (Hujanen et al., 1991), loading of filters with particulate matter was also found to increase odor emissions. Because the filters were collected for evaluation of odor emissions after their normal period of use, which varied from 4 to 38 months, it was difficult to evaluate the development of the odor emission rate with the loading of the filter. How-

ever, the results obtained suggested that the development of odor emission depends not only on the total filtered air volume, but also on the quality of the ambient air in the location of AHU.

The first goal of this study was to investigate the development of odor generation in ventilation filters during normal use. The second goal was to find out whether the particle size of atmospheric dust affects the odor emission rate and whether the use of frequently changed prefilters decreases the odor load of the supply air. The third goal was to evaluate whether pressure drop is a sufficient criterion for filter change when high indoor air quality is required.

Methods

Monitoring of Filter Loading

Air-handling units in six mechanically ventilated buildings were chosen as loading sites for the filters. The buildings were situated in the center of the city of Helsinki. The filter unit was placed as the first component in the AHU. Typically the AHUs of these buildings included heat recovery unit, heat exchanger and fan in this order. Two of the filter units (units 5 and 6) were equipped with coarse prefilters of EU3 type (with an average dust weight arrest for artificial dust of 80–90%, SFS 5150 (1986)).

The increase in odor emission from controlled loaded ventilation filters was followed periodically for half a year. One standard-size (60 cm · 60 cm) filter cassette in each ventilation system was replaced by a new filter frame that contained four 30 cm · 30 cm filter cassettes. These glass fiber filters were classified as EU6 class (tested according to SFS 5150, the average dust spot efficiency being 60–80%, ASHRAE 52–76 (1976)). The synthetic prefilters (EU3) were also divided into 30 cm · 30 cm pieces in their own frames. Operational and design parameters for the AHUs are shown in Table 1.

Filter loading began at the end of summer, in August, when the total suspended particles concentration is usually at its lowest value (60 to 90 µg/m³) (Aarnio et al., 1992) and the concentration of particles of natural origin e.g. pollen, is also lower than earlier in the summer. All 24 fine filters and 8 prefilters were weighed before installation. The sealing of the filter cassette was checked before measuring the pressure drop over the filter.

Table 1 The face velocity, filter type and weekly operation time of the AHUs studied

AHU	Type of filter*	Face velocity (m/s)	Operation time (h/week)
1	GF	3.36	80
2	GF	2.24	53
3	GF	3.68	53
4	GF	6.68	63
5	PRE + GF	2.72	50
6	PRE + GF	0.64	113

*GF = glass fiber, PRE = prefilter.

Outdoor Particle Samples

To evaluate the odor emission of outdoor particles, atmospheric dust samples were collected using a modified high volume impactor (Andersen model 234), which was used with the standardized high volume sampler. The particles were divided into three fractions; the cut-off sizes of the impactor were 10.0 µm and 2.1 µm, and the finest fraction (< 2.1 µm) was collected on a glass fiber filter. The flow rate of the impactor was regulated to 0.570 m³/min. Three-day samples were taken during November in Helsinki, and samples were also taken in Kuopio, 400 km to the north of Helsinki, to complement data from our previous study (Hujanen et al., 1991).

Analysis

After each loading period (6, 13, 19 and 26 weeks), one of the four 30 cm · 30 cm filters from each 60 cm · 60 cm filter cassette was changed and carefully transported to the laboratory, where the loaded filters were first weighed in constant temperature and relative humidity (20°C, RH 50%). The odor emission and pressure drop of each filter were then determined.

A small-scale AHU was built in the laboratory for odor evaluation (Figure 1). The face velocity through the filter was 1.0 m/s, and temperature of the air was maintained at +20°C (± 0.5°C) by a heat exchanger with a low surface temperature. Air samples for odor intensity evaluation were taken both upstream (1) and downstream (2) of the filter. An outdoor air reference sample (3) entered through an aluminum-coated flexible hose made of a low-emission material. The temperature of the reference sample was controlled outside of the hose. The velocity in the sample outlet was adjusted with the aid of a variable-speed fan to 1 m/s (± 0.05 m/s), and temperature was regulated to +20.0°C (± 0.5°C).

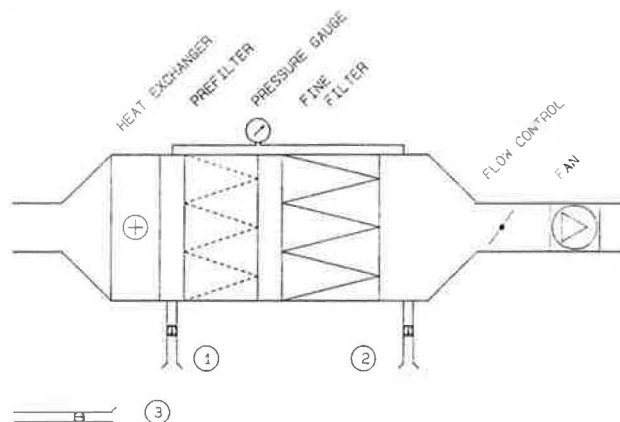

Fig. 1 Air-handling unit and sampling sites for odor evaluation. Samples (1) before and (2) after the filter; (3) the heated outdoor air reference sample.

The filter was stabilized in the AHU for one hour before the odor evaluation. Finally, the pressure drop over the filter was measured.

The odor intensities of the air samples were evaluated by a trained panel of 6–10 members. The members of the panel were selected from laboratory personnel according to ASTM Standard STP 440 (1968). The panel was trained using the varying odor intensities of a dilution series of butanol mixtures in water. An exponential, ten-point scale of butanol mixtures in concentrations of 10–5120 ppm was used as a reference (ASTM Standard E-544 (1975)) during the odor evaluation. Each panellist worked individually and marked his/her evaluations of each sample on a separate sheet using a scale from 1 to 10. The sample lines were arranged so that the panellists could not know where the sample came from or which type of filter was in the AHU. The panellists were able to breathe fresh air at an open door during the test.

The odor intensity caused by the odor emission from the filter was calculated as an average of the individually perceived intensities. The average intensity was calculated by subtracting the perceived odor intensity before the filter from the perceived intensity after the filter. This result obtained on the butanol scale was converted to percentage of dissatisfied (PD) according to the equation (1) presented by Hujanen et al. (1991).

$$PD = 20.89 (\ln C_b) - 46.79 \quad (1)$$

where PD = percentage of dissatisfied

C_b = concentration of butanol in ppm units

For the comparison to other studies, the PD is converted to the decipol units according to Fanger's (1989) equation (2)

$$C = 112 (\ln(PD) - 5.98)^{-4} \quad (2)$$

where C = odor intensity in decipol units

PD = percentage of dissatisfied

The odor emissions of the dust samples collected with the high volume impactor were also evaluated in the laboratory. The impaction plates, the coarse fraction, the middle fraction and the filter (finest fraction) were put into decipolmeter as described by Bluysen and Fanger (1990), and the odor emissions were analyzed by the trained panel.

Results and Discussion

The weekly dust accumulation rates on the filters at the various loading sites varied with time (Table 2). The weekly operation time, and the flow parameters of the AHU (Table 1) and variations in total suspended particle concentration affected the amount of dust collected on the filters during each loading period. According to air pollution monitoring data taken during the study (Aarnio et al., 1992), both buildings (5 and 6) using AHUs equipped with prefilters were situated in an area where total suspended particle concentration was 20–30% lower than in the heavily polluted downtown area. Consequently, the dust accumulation rates were lower for these systems than for the fine filters without prefilters (Table 2). Dust accumulation rates of the prefilters are presented on the second line of Table 2. The third line represents the total mass collected on both filters.

The odor intensities of the unused glass fiber and polyester filters were negligible. Bluysen (1990) found that the source strength of an unused glass fiber filter (EU7) was far below (about 7 olf) that

Table 2 The averages of weekly dust accumulation rates on the filters in different loading periods. AHUs numbered 5 and 6 were equipped with prefilters

Filter type	Dust accumulation rate (g/week)				
	Period	0–6	6–13	13–19	19–26
Fine filter (AHU 1–4)		1.96	1.29	2.36	1.29
Prefilter (AHU 5–6)		0.84	0.47	0.68	0.45
Pre + fine (AHU 5–6)		1.30	0.72	0.83	0.55

Table 3 Percentage dissatisfied, difference in perceived air quality before and after the filter, total air volume, and pressure drop over filter after periods of 6, 13, 19 and 26 weeks

Filter loading time	Number of the site, glassfiber filters without prefilters							
	Mean	1 95% conf.	Mean	2 95% conf.	Mean	3 95% conf.	Mean	4 95% conf.
Dissatisfied (%)								
After 6 weeks	2.8	-8.7-14.2	28.5	18.5-38.4	1.3	14.0-16.6	0.7	0.1-1.4
13 weeks	27.4	22.3-32.5	46.2	33.3-59.1	31.5	15.4-48.0	31.7	21.6-41.9
19 weeks	48.4	39.1-57.7	37.5	32.8-42.2	21.8	8.3-35.4	43.3	30.1-56.5
26 weeks	43.3	33.1-53.5	42.3	30.4-54.2	23.0	7.9-38.2	27.9	16.0-39.8
Differences of PAQ over filter (decipol)								
After 6 weeks	0.2	na-0.9	2.3	1.3-3.8	0.1	1.1-2.7	0.1	0-0.1
13 weeks	2.2	1.6-2.9	5.3	3.0-8.6	2.7	1.0-5.7	2.8	1.6-4.4
19 weeks	5.7	3.9-8.2	3.6	2.9-4.5	1.6	0.5-3.3	4.7	2.5-7.8
26 weeks	4.7	3.0-7.0	4.5	2.6-7.2	1.7	0.5-3.8	2.3	1.1-4.0
Total air volume (10⁶m³)								
After 6 weeks	0.302		0.252		0.263		0.313	
13 weeks	0.786		0.439		0.570		0.678	
19 weeks	1.149		0.599		0.834		0.991	
26 weeks	1.572		0.786		1.141		1.356	
Pressure drop (Pa)								
After 6 weeks	20		19		36		39	
13 weeks	25		34		41		65	
19 weeks	56		43		34		38	
26 weeks	51		52		43		25	

PAQ = perceived air quality, 95% conf. = 95% confidence interval, na = not available

Table 3 Continued

Filter loading time	Number of the site, fine filters with prefilters											
	5 GF		5 PRE		5 GF+PRE		6 GF		6 PRE		6 GF+PRE	
	Mean	95% conf.	Mean	95% conf.	Mean	95% conf.	Mean	95% conf.	Mean	95% conf.	Mean	95% conf.
Dissatisfied (%)												
After 6 weeks	0.0	-13.5-13.5	8.6	1.6-15.5	8.6	-0.9-18.0	4.9	-9.5-19.4	24.8	17.9-31.8	23.0	14.2-31.9
13 weeks	10.4	-6.3-27.1	32.7	16.8-48.6	25.9	18.3-33.5	18.7	15.6-21.8	17.2	5.8-28.7	19.4	12.9-25.9
19 weeks	18.7	6.6-30.7	27.9	16.9-38.8	32.7	20.8-44.6	14.3	6.9-21.7	24.5	15.2-33.8	25.9	17.3-34.5
26 weeks	15.8	2.1-29.5	32.1	19.9-44.3	27.9	15.5-40.2	14.9	5.7-24.1	11.4	0.1-22.8	24.1	12.8-35.3
Differences of PAQ over filter (decipol)												
After 6 weeks	0	na-0.9	0.5	0.1-1.0	0.5	na-1.2	0.3	na-1.4	1.9	1.2-2.8	1.7	0.9-2.8
13 weeks	0.6	na-2.2	2.9	1.1-5.8	2.0	1.3-3.0	1.3	1.0-1.6	1.2	0.4-2.4	1.4	0.8-2.0
19 weeks	1.3	0.4-2.6	2.3	1.1-3.9	2.9	1.5-4.9	0.9	0.4-1.6	1.9	1.0-3.1	2.0	1.2-3.2
26 weeks	1.0	0.1-2.5	2.8	1.4-4.9	2.3	1.0-4.1	1.0	0.3-1.8	0.7	0.0-1.7	1.8	0.8-3.3
Total air volume (10 ⁶ m ³)												
After 6 weeks	0.184		0.184		0.184		0.182		0.182		0.182	
13 weeks	0.398		0.398		0.398		0.297		0.297		0.297	
19 weeks	0.581		0.581		0.581		0.395		0.395		0.395	
26 weeks	0.796		0.796		0.796		0.510		0.510		0.510	
Pressure drop (Pa)												
After 6 weeks	49		14		-		19		27		-	
13 weeks	70		14		-		55		23		-	
19 weeks	38		19		-		36		38		-	
26 weeks	68		17		-		66		38		-	

PAQ = perceived air quality, GF = glass fiber, PRE = prefilter, GF + PRE = both filters together, 95% conf. = 95% confidence interval, na = not available.

of the used filters (from 40 to 150) when 100 l/s of air was led through the filters. Odor emissions from the filters clearly increased after six weeks of use in every site (Table 3). In most of the loading sites and periods, the whole 95% confidence interval of the odor intensity is above the initial level. The percentage dissatisfied (PD) increased during the 19-week period to a level where every third person would be dissatisfied for fine filters without prefilters. Odor emissions from filters have previously been reported to rise strongly during two months (Bluyssen, 1993). When prefilters were used, they were found to catch effectively the odorous part of outdoor pollutants. The maximum PD for the prefilters was 31.5%, but the maximum PD of the main filter was only 14%. Therefore, use of frequently changed, disposable prefilters would be an effective and inexpensive way to raise the quality of supply air.

The total air volume that passed through the filter was calculated from the measured air volume rate and the weekly operating time (Table 3). As expected, the pressure drop over the filter increased with the loading of the filter, but in the AHUs at sites 4 and 5 pressure drops were at the highest level after 13 weeks. For site 1 and the prefilters of site 5, the highest pressure drop was achieved after 19 weeks. The pressure drop correlated poorly with the odor emission of the filter, indicating that pressure drop is not a suitable criterion for filter change if hygienic aspects are considered. Furthermore, during our study, the pressure drop across the filters did not reach the value recommended as a criterion for filter change.

The PD was related to the amount of dust accumulated on the filter; the average PD became as high as 40% when the amount of dust on EU6 classified fine filter was over 30 g/filter or 20 g/m² expressed as surface density on filter material (Figure 2). The corresponding values were similar for prefilters and the fine filters downstream from them when the total amount of dust was taken into account (Figure 3). The filter type or material did not affect the odor emission rate. In our earlier study, odor emissions from heavily loaded filters correlated well with the total filtered air volume in the most polluted area, but the correlation was only weak in filters collected from less polluted areas (Hujanen et al., 1991). In this study, the odor emission rate was slightly correlated with the total air volume passed through the filter.

The relative odor emission of dust collected in

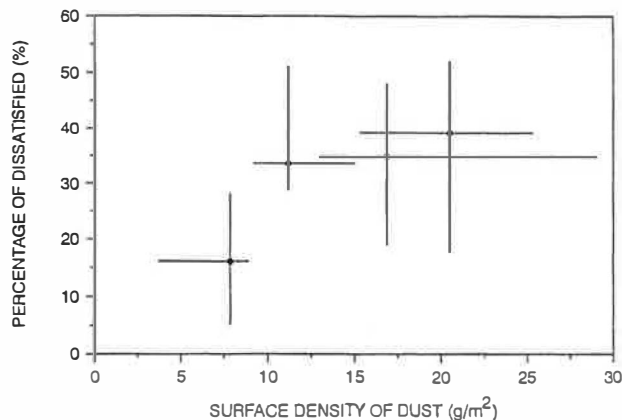

Fig. 2 Average ($n = 4$), maximum and minimum percentage dissatisfied as a function of the surface density of dust accumulated on fine filters without prefilters.

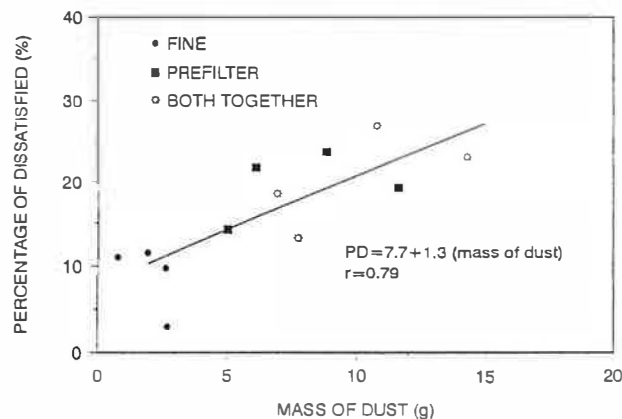

Fig. 3 The effect of accumulated dust mass on percentage dissatisfied for fine filters, prefilters, and fine filters and prefilters combined. Odor emission was evaluated separately in all cases.

the winter (filters studied in December and February) was lower than that of dust collected in the fall (Figure 4). The highest relative odor emission from filters was obtained after the collection period from September to November when the relative humidity of air is high. Availability of water provides fungal growth in porous and dirty materials such as filters (Martikainen et al., 1990) producing odorous compounds (Bjurman, 1993; Pasanen et al., 1990). This might be one of the reasons for the elevated odor emission of the filter in that period. It can be assumed that the mean diameter of particles caught on coarse filters is larger than that of particles caught on fine filters and therefore, that particles on coarse filters have less surface area per mass unit than particles on fine filters. In spite of the relatively smaller surface area, the particles on the coarse prefilters released more odor per mass unit (Figure 4). This result agrees well with the results obtained from

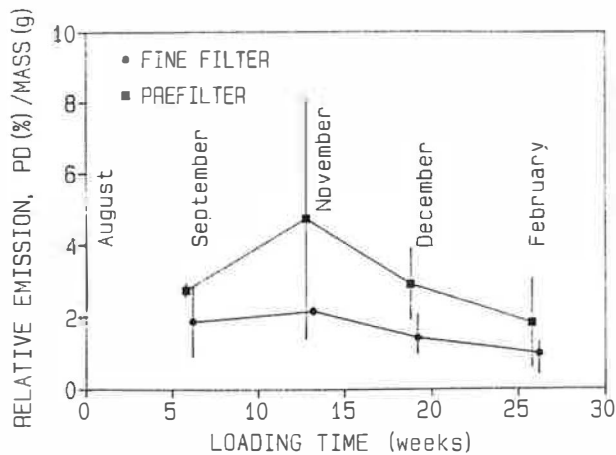

Fig. 4 Average and range of percentage dissatisfied per mass of dust on prefilters ($n = 2$) and fine filters without prefilters ($n = 4$) after various loading times during fall and winter.

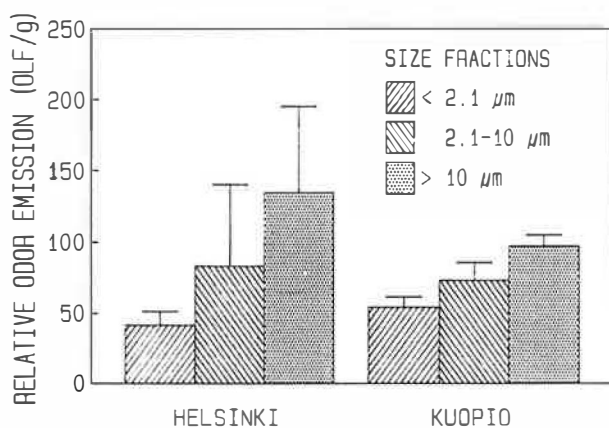

Fig. 5 Relative odor emission with standard error of mean from different size fractions of dust collected from Helsinki and Kuopio. The samples were taken in November 1991.

samples collected by the Andersen high volume impactor (Figure 5). The relative odor emission per mass unit was highest for the coarsest fraction ($d_p > 10 \mu\text{m}$) and lowest for the finest fraction ($< 2.1 \mu\text{m}$). The relative odor emission of dust was found to be higher in Helsinki than in Kuopio, supporting the results of our preliminary study, which indicated that odor emissions from ventilation filters were higher in Helsinki than in Kuopio. Local variation within the city has also been reported by Hujanen et al. (1991).

Conclusions

The development of odor emission was observed to be related to amount of the dust collected on the filters. During the first three months, the odor emissions increased steadily to a level that every third

person would consider unacceptable for indoor air quality. The season affected the relative odor emission of the loaded filters; in the study period from August to February, the emission was the highest in the fall and at the lowest during winter time. This indicates that microbial growth and decomposition of collected particles in an air filter is an important source of odorous compounds from an air filter. Pressure drop, the usual technical criterion for filter change, did not correlate well with the odor emission of the filter or even with the volume of filtered air. Therefore, pressure drop alone is not an adequate criterion for changing supply air filters when hygienic aspects are considered.

The relative odor emission of the coarse fraction ($d_p > 10 \mu\text{m}$) of atmospheric particles was higher than that of smaller particles. The increase in the odor emissions from coarse prefilters was similar to that of fine filters without prefilters, and the use of prefilters decreased the odor emissions from the main filtering unit. Therefore, use of frequently changed coarse prefilters is recommended to minimize odor emissions from ventilation filter units when high indoor air quality is required.

Acknowledgements

This research was supported by the Ministry of the Environment of Finland and by the LVIS-2000 Research Program of the Ministry of Trade and Industry of Finland. The authors thank all the maintenance personnel of the buildings studied for their valuable aid.

References

- Aarnio, P., Hämeoski, K. and Kaskentalo, T. (1992) *Air Quality in Helsinki Metropolitan Area*, Helsinki Metropolitan Area Council Publications, Series C 1992:3 (in Finnish).
- ASHRAE (1976) *Method of Testing Air-Cleaning Devices used in General Ventilation*, Atlanta, GA, American Society of Heating, Refrigerating and Air-Conditioning Engineers (ASHRAE Standard 52-76).
- ASTM (1968) *Correlation of Subjective-Objective Methods in Study of Odors and Taste*, Philadelphia, American Society for Testing Materials (Standard STP 440).
- ASTM (1975) *Standard Practices for Referencing Suprathreshold Odor Intensity*, Philadelphia, American Society for Testing Materials (Standard E-544-1975).
- Bjurman, J. (1993) "Thermal insulation materials, microorganisms and the sick building syndrome". In: Kalliokoski, P., Jantunen, M. and Seppänen, O. (eds) *Proceedings of Indoor Air '93*, Helsinki, Vol. 4, pp. 339-344.
- Bluyssen, P. M. (1990) *Air Quality evaluated by a Trained Panel*, Copenhagen, Technical University of Denmark (Ph.D. thesis).

- Bluyssen, P.M. (1993) "Do filters pollute or clean the air". *Air Infiltration Review*, 14 (2), 9-13.
- Bluyssen, P.M. and Fanger, P.O. (1990) "Addition of olfs from different pollution sources". In: Walkinshaw, D.S. (ed.) *Proceedings of Indoor Air '90*, Ottawa, Canada Mortgage and Housing Corporation, Vol. 1, pp. 569-574.
- Fanger, P.O. (1989) "The new comfort equation for indoor air quality", *ASHRAE Journal*, October, pp. 33-38.
- Fanger, P.O., Lauridsen, J., Bluyssen, P.M. and Clausen, G. (1988) "Air pollution sources in office and assembly halls, quantified by the olf unit", *Energy and Buildings*, 12, 7-19.
- Finnegan, M.J. and Pickering, A.C. (1987) "Prevalence of symptoms of sick building syndrome in buildings without expressed dissatisfaction". In: Seifert, B., Esdorn, H., Fischer, M., Ruden, H. and Wegner, J. (eds.) *Proceedings of Indoor Air '87*, Berlin (West), Institute of Water, Soil and Air Hygiene, Vol. 2, pp. 542-546.
- Hujanen, M., Seppänen, O. and Pasanen, P. (1991) "Odor Emission from the used filters of air-handling units". In: *Proceedings of Healthy Buildings, IAQ 91* Atlanta, ASHRAE, pp. 329-333.
- Jaakkola J.J.K., Miettinen P., Tuomaala P. and Seppänen O. (1993) "The Helsinki office environment study: the type of ventilation system and the 'sick building syndrome'". In: Jaakkola, J., Ilmarinen, R. and Seppänen, O. (eds) *Proceedings of Indoor Air '93*, Helsinki, Vol. 1, pp. 285-290.
- McJilton, C.E., Reynolds, S.J., Streifel A.J. and Pearson R.L. (1990) "Bacteria and indoor odor problems three case studies", *American Industrial Hygiene Association Journal*, 51, 545-549.
- Martikainen, P., Asikainen, A., Nevalainen, A., Jantunen, M., Pasanen, P. and Kalliokoski, P. (1990) "Microbial growth on ventilation filter materials". In: Walkinshaw, D.S. (ed.) *Proceedings of Indoor Air '90*, Ottawa, Canada Mortgage and Housing Corporation, Vol. 3, pp. 203-206.
- Morey, P.R. and Williams C.M. (1991) "Is porous insulation inside an HVAC system compatible with a healthy building?". In: *Proceedings of Healthy Buildings, IAQ 91* Atlanta, ASHRAE, pp. 128-135.
- Pasanen, P., Tarhanen, J., Kalliokoski, P. and Nevalainen A. (1990) "Emissions of volatile organic compounds from air conditioning filters of office buildings". In: Walkinshaw, D.S. (ed.) *Proceedings of Indoor Air '90*, Ottawa, Canada Mortgage and Housing Corporation, Vol. 3, pp. 183-186.
- Pejtersen, J., Bluyssen, P.M., Kondo, H., Clausen, G. and Fanger, P.O. (1989) "Air pollution sources in ventilation systems". In: Kulić, E., Todorović, B. and Novak, P. (eds) *Proceedings of CLIMA 2000*, Sarajevo, Vol. 3, pp. 139-144.
- Robertson, A.S, Roberts, K.T., Burge, P.S. and Raw, G. (1990) "The effect of change in building ventilation category on sickness absence rates and the prevalence of sick building syndrome". In: Walkinshaw, D.S. (ed.) *Proceedings of Indoor Air '90*, Ottawa, Canada Mortgage and Housing Corporation, Vol. 1, pp. 237-242.
- Ruotsalainen, R., Rönnerberg, R., Majanen, A., Seppänen, O. and Jaakkola, J. (1990) "Symptoms and environmental complaints in occupants of houses and apartments with different ventilation systems". In: Walkinshaw, D.S. (ed.) *Proceedings of Indoor Air '90*, Ottawa, Canada Mortgage and Housing Corporation, Vol. 1, pp. 525-530.
- SFS (1986) *Air Conditioning. Testing of Air Filters*. Helsinki, Finnish Standard Association SFS (Standard 5150) (in Finnish).