

#6490-EN

**VENTILATION FILE**

**A Compendium of Canadian  
Ventilation  
Research and Demonstration  
Project Results**

**Final Report**

**Prepared for:**

**Housing Innovation Division  
Canada Mortgage and Housing Corporation  
Ottawa, Ontario**

**Prepared by:**

**Caneta Research, Inc.  
Mississauga, Ontario**

**April, 1992**



# **VENTILATION FILE**

## **A Compendium of Canadian Ventilation Research and Demonstration Project Results**

### **Final Report**

**Prepared for :**

**Project Implementation Division,  
Canada Mortgage and Housing Corporation  
Ottawa, Ontario**

**Prepared by :**

**Caneta Research, Inc.  
Mississauga, Ontario**

**April, 1992**

**NOTE:** Aussi disponible en français sous le titre: Dossier sur la ventilation: un recueil des résultats de projets canadiens de recherche et démonstration en ventilation: rapport final

## TABLE OF CONTENTS

<b>ABSTRACT</b>	v
<b>1. AN OVERVIEW OF VENTILATION RESEARCH AND DEMONSTRATION EFFORTS IN CANADA</b>	1 - 1
<b>2. VENTILATION REQUIREMENTS</b>	
Summary	
Airtightness	2 - 1
Natural Ventilation and Infiltration	2 - 5
Occupant Ventilation / Contaminant Control	2 - 9
Humidity and Condensation Control	2 - 13
Make-Up Air Requirements	2 - 17
Ventilation / Distribution Effectiveness	2 - 21
Codes and Standards	2 - 23
<b>3. VENTILATION EQUIPMENT AND COMPONENTS</b>	
Summary	
Ventilation Fans	3 - 1
Make-Up Air Devices	3 - 3
Ventilation Controls	3 - 7
Ventilation System Components	3 - 11
Heat Recovery Ventilators	3 - 13
Integrated Heating and Ventilation Equipment	3 - 15
Equipment Performance Standards	3 - 17
<b>4. VENTILATION SYSTEMS</b>	
Summary	
Point Exhaust	4 - 1
Central Exhaust	4 - 3
Balanced Ventilation	4 - 7
Supply-Only	4 - 9
Dynamic Wall	4 - 11
Fresh Air Supply to Return Air	4 - 15
Passive Ventilation	4 - 17
Northern or Remote Housing Ventilation	4 - 21
<b>5. REFERENCES</b>	



## **ABSTRACT**

**This report is a consolidation of information published in Canada as a result of research and demonstration projects on ventilation requirements, equipment and systems. Each of the three subject areas are divided into individual topic areas which address significant findings from Canadian research. It provides an overview of these efforts, draws conclusions and makes recommendations for future research, technology transfer and demonstration.**





# **1. AN OVERVIEW OF VENTILATION RESEARCH AND DEMONSTRATION EFFORTS IN CANADA**



## INTRODUCTION

This document has been prepared to consolidate the vast information published in Canada as a result of research and demonstration projects on ventilation requirements, equipment and systems.

Over the past several years, numerous ventilation research and demonstration projects have been conducted throughout the country, including several projects looking specifically at means of satisfying the requirements of Standard CSA-F326: Residential Mechanical Ventilation Systems.

Canada Mortgage and Housing Corporation (CMHC) are currently responsible for nearly 50% of the ventilation projects underway throughout the country. Other agencies include Energy, Mines and Resources Canada, the National Research Council and Alberta Municipal Affairs, to name a few.

CMHC, amongst others, felt that there was a need to step back from all these ventilation initiatives and consolidate the findings to date. The consolidation can serve several purposes:

- provides the opportunity for government and industry to re-examine the current thinking, design and practice in ventilation requirements, equipment and components, and systems.
- identifies gaps in knowledge or technology that assists CMHC and other funding agencies to develop more effective research and demonstration projects.
- increases awareness of research efforts of the various funding agencies and minimizes redundant research.
- assists industry or manufacturers to target new product lines more consistent with the needs of the builders.
- provides builders and designers with the ability to make an informed choice for a particular ventilation system, based on technical and economic criteria.
- promotes the level of technical excellence, knowledge and innovation abundant in Canada in the field of ventilation to both Canadian and international audiences.

The material in this document is organized into three broad subject or theme areas described as follows:

- **Ventilation requirements.** Here research and demonstration efforts which investigated: the amount of fresh air or ventilation air needed for occupant health, the control of contaminants or moisture levels or the make-up air needed to avoid house depressurization due to operation of exhaust or combustion appliances, are reported. The airtightness of housing and the effectiveness of the ventilation air distribution fall within this subject area as well, as do methods of measuring the same.
- **Ventilation equipment and components.** Here research efforts have examined the air flow and other performance characteristics of exhaust fans, heat recovery ventilators and other components, such as ductwork, terminations and fittings. Integrated heating and ventilation equipment has more recently been the subject of significant research and development.
- **Ventilation systems.** This subject covers research and demonstration efforts which have examined the performance, relative merits and applicability of a number of ventilation system types. The systems examined have included point exhaust, central exhaust, balanced, supply-only, fresh air supply to return air, dynamic wall and passive ventilation.

This chapter will provide an overview of the status of each of the three major subject areas drawn from Canadian research and demonstration efforts in ventilation. Each section includes the significant findings and conclusions. This chapter is concluded with recommendations for future research, technology transfer and demonstration.

The more serious reader is invited to read the twenty-two subject or theme areas throughout this document and for further reading can obtain the original works compiled in the References chapter. A total of eighty-two documents were reviewed and represent the scope of the work in preparation of the "Ventilation File." Both CMHC and the authors are aware of other work which for one reason or another could not be included in this review.

## VENTILATION REQUIREMENTS

The **airtightness** of Canadian housing has significantly increased. By 1989, 70 percent of the houses surveyed in one study [37] had natural air leakage rates less than 0.3 air changes per hour.

## 1. AN OVERVIEW OF VENTILATION RESEARCH AND DEMONSTRATION EFFORTS IN CANADA

There appears to be a trend to increasing airtightness in colder climates. This trend is thought to be influenced by concerns for both comfort and operating costs. The increased incidence of indoor pollution and moisture problems are other apparent results of the increased air tightness of Canadian houses.

While **natural ventilation** can no longer be relied upon to provide adequate air quality, it is important because it may be the only source of ventilation where the existing mechanical system is ineffective or not utilized by the occupants.

Recent research efforts have shown that increasing ventilation rates to control most contaminant levels has limited effect beyond about 0.3 air changes per hour. The current thinking is to reduce the contaminants or **pollutants** at their source, by removal or with point exhaust equipment. Greater ventilation rates can be provided if needed for periods with temporary indoor air quality problems.

**Make-up air** in tighter houses should be provided by mechanical means. Naturally-aspirated furnaces do not compete successfully with most exhaust devices found in the modern home, unless make-up air is provided. A recent study by CMHC [35] concluded that a typical residential bathroom fan, a range hood fan and a clothes dryer have sufficient exhaust flow capacity that, acting together, they would cause a depressurization of 5 Pa or greater in almost 50 percent of the houses tested. This depressurization of 5 Pa is the limit specified in Standard CSA-F326 for houses equipped with naturally-aspirated appliances. Properly sized make-up air devices need to be interlinked to exhaust device operation to prevent spillage and backdrafting.

Most **codes and standards** specify ventilation air requirements on a room-by-room basis. Satisfying ventilation requirements goes beyond merely introducing fresh air. One needs to ensure that adequate amounts are supplied in all occupied rooms or zones. Houses with air distribution systems generally have substantial mixing of air from all rooms, thereby ensuring **ventilation effectiveness**.

Outlet designs are important to avoid occupant discomfort particularly during equipment off-cycles. This could be accomplished with high inside-wall supply vents to ensure that cool fresh air in winter is introduced above the occupied

zone. The more common floor supply perimeter outlets may require tempering of air before introduction to the room to avoid occupant discomfort.

The current National Building Code 1990 requires that all houses must be provided with ventilation systems capable of introducing outside air at a rate not less than 0.3 air changes per hour, averaged over 24 hours. If air is to be exhausted to meet this requirement, make-up air must be provided to prevent house depressurization that would cause combustion gas spillage. These requirements were adopted by the Ontario building code in January 1991. The British Columbia building code requires 0.5 air changes per hour for non-distributed ventilation systems; 0.3 for distributed. In both cases, 0.25 air changes per hour of the required capacity is to be provided by an exhaust fan controlled by a dehumidistat.

By 1995, the National Building Code may adopt Standard CSA-F326 in whole or in part. The CSA Standard includes an over-all minimum ventilation requirement of 0.3 air changes per hour. It is expected that many Provincial Codes will adopt the same provisions for ventilation requirements.

### VENTILATION EQUIPMENT AND COMPONENTS

Recent laboratory tests found that while the majority of range hood fans were found to achieve manufacturer rated airflow, bathroom fans were significantly below rating.

The flows and pressure differences typical of residential ventilation systems in theory require only small amounts of fan power. In practice, however, anywhere from 100 to 200 watts input of electrical power was required to impart 4 watts of power to the ventilation air stream, based on laboratory tests of exhaust fans. This inefficiency needs to be significantly improved, otherwise provision of continuous ventilation by mechanical means will become prohibitively expensive.

**Ventilation controls** vary anywhere from a simple on-off switch, to a mechanical timer to delay fan shut-off, all the way up in sophistication to a pressure-activated control that senses pressure imbalance and activities fans, heaters or deactivates other exhaust devices in the house to restore pressure balance.

## 1. AN OVERVIEW OF VENTILATION RESEARCH AND DEMONSTRATION EFFORTS IN CANADA

---

Humidity controls are not effective at controlling average humidity levels and are judged to be effective as peak humidity controllers, at best. Humidity-controlled fresh air inlets and extractors are available in the market. These gave mixed results and were found to not respond well to small humidity increases. Their response was slow and their effect on ventilation rate was small.

**Make-up air devices** in the marketplace were found to be inadequate in one area or another. Some suffer from thermal lag and are unable to compensate for other exhaust devices' effects on house pressure. Some depend on the operation of a furnace fan to provide make-up air. Motorized - dampers, in combination with a triggering device activated by operation of other exhaust devices might offer an effective solution in provision of make-up air.

A pressure-activated diaphragm control developed with CMHC funding showed promise. Displacement of the diaphragm by pressure imbalance led to the activation of a two-speed fan and ducts heater, as needed. The same control could power dampers or turnoff exhaust appliances or a combination of devices to keep house pressure within limits set out in CSA-F326.

**Heat recovery ventilator (HRV)** performance has improved significantly over the years because of the R2000 mandatory HRV equipment certification testing and installer training. Early HRV systems suffered from poor duct design, excessive uses of flexible duct or smaller diameter duct than required. Second generation HRV installations have significantly improved quality.

**Integrated heating and ventilation equipment**, under development with funding from CMHC, operates on the principle that heating/ventilation/exhaust appliances should work in harmony to ensure occupant safety in homes with combustion appliances. CMHC has sponsored three prototype developments: the Air Management System, the Air Management Module and a motorized-damper-equipped HRV. Each prototype attempts to control the amount of fresh or exhaust air as needed to maintain house pressure balance.

This is done in the first case with a mixing box for controlling the amount of fresh air and recirculation air. In the case of the Air Management Module (AMM), a central exhaust fan is speed modulated to vary exhaust flow in

response to other exhaust device operation. The fresh air brought in by the AMM is matched to the exhaust flow. Exhaust devices can be deactivated, if needed.

The third development allows an HRV's supply and exhaust flows to be regulated to maintain house pressures within limits specified by CSA-F326. The unit is controlled by a microprocessor with a pressure sensor measuring inside-outside pressure difference. The presence of other exhaust devices is not known, nor is it required to maintain house pressure balance.

**Equipment performance standards** developed by CSA, now provide uniform test methods and rating conditions for determining airflow performance and sound output of HRVs and other residential mechanical ventilation equipment. The two standards are CSA-C439-88 and CSA-C260-M90, respectively. Both are referenced in CSA-F326. If CSA-F326 is "called up" by the 1995 National Building Code and by provincial codes, performance testing and rating of HRVs and other residential mechanical ventilation equipment will become mandatory. CSA-F326 also requires that other ventilation system components, such as wall and roof caps, flexible ducting, and other components be accompanied by published data on pressure loss and flow rate characteristics, for design purposes.

### VENTILATION SYSTEMS

**Point exhaust systems** are the most common ventilation system used in Canadian housing. There are no elaborate distribution or duct systems required. Duct leakage and friction losses can be largely eliminated or reduced. Control wiring is not needed and the systems are relatively easy to retrofit. Disadvantages include difficulty in recovering heat from multiple point exhaust systems; more fans are involved; and the equipment is often noisy and ineffective. Field installed point exhaust systems have been found to deliver only 50 percent of their rated flow capability.

**Central exhaust systems**, while less common in Canada, have a number of advantages. The single exhaust fan and outlet permit heat recovery. Control requirements can be relatively simple. There are limited envelope penetrations. They can be better "integrated" to control house pressure balance than point exhaust systems.

## 1. AN OVERVIEW OF VENTILATION RESEARCH AND DEMONSTRATION EFFORTS IN CANADA

The disadvantages include the high cost to retrofit such systems in existing housing. There is also a cost difference in new construction, due to the expense associated with ducting from the various exhaust pick-up points to the central fan. If speed control is desired at each pick-up point, control complexity and cost can be greater.

There are a large number of central exhaust system types, including HRVs, distributed inlet and humidity-controlled extractor systems. Distributed systems provide effective means of removing contaminants and providing fresh air where it is needed. Humidity-controlled systems vary exhaust flow on the basis of humidity. Humidity, however, is not always a good indicator of occupancy.

**Balanced ventilation** systems have the important advantage of not affecting the house pressure. They do not create overpressure that can cause condensation, nor negative pressure that can cause infiltration of outdoor air, the backdraft/spillage of combustion products, and in some cases, increase the chances of entry of soil gases such as radon.

Disadvantages of balanced ventilation systems include the plugging of screens, filters and the resulting imbalanced flow. The inability to compensate for other exhaust devices adversely affects house pressure. Finally, in the case of HRV systems, the potential exists for blockage with snow, frost and ice if the defrost system is ineffective or settings of the defrost controls are incorrect.

**Supply-only** ventilation systems are relatively simple, are of low cost and do not create venting problems with naturally-aspirated combustion appliances. They do not create cold drafts from leaks in the envelope, nor do they draw in contaminants, such as radon, formaldehyde or other soil gases.

However, supply-only systems do pressurize the space and increase the risk of humid air leaking through the envelope and contributing to potential moisture damage, freezing of door locks or the like. There may be a need to pre-heat the incoming supply of fresh air to avoid occupant discomfort.

One such system has been recently investigated. A crawl space was pressurized by a supply fan with fresh air. Vents in the floor allow pre-heated

fresh air to enter the living space. Air quality was reported to be excellent. More information on this system can be found in Chapter 4.

The **dynamic wall** concept involves bringing in fresh air uniformly through the envelope materials and thereby pre-heating the incoming supply air. Exfiltration related damage to the envelope is prevented. Heat can be recovered from the central exhaust air and since the incoming air is pre-heated, there are no cold drafts.

One disadvantage of this concept is the potential for backdrafting/spillage of combustion products in houses with naturally aspirated combustion appliances. Another is that all ventilation air is drawn through the wall or envelope system which is inaccessible for inspection or cleaning. The latter situation may result in particulate carryover or other contaminant emissions from the wall cavity. The performance of one such system was evaluated in a project for CMHC [78]. Net savings in ventilation energy of about 15 percent were claimed compared to conventional construction and ventilation system design.

One of the simplest and more commonly used ventilation systems is a fresh air supply to return air connection to the furnace plenum. This approach utilizes the existing distribution system to distribute fresh air. It is also low cost, simply involving a penetration through the envelope, ductwork and a wallcap. If necessary, it can be supplemented by a separate fan.

There are a number of potential disadvantages. These systems tend to pressurize the house, and are dependent on furnace operation that is both cyclic and seasonal. Running the furnace fan continuously is expensive and may cause occupant discomfort during furnace off-cycles. The vent connection may have limited flow capacity, particularly when other exhaust appliances are operating. There is also a potential for condensation and corrosion problems inside the furnace heat exchanger.

**Passive ventilation** systems utilize intentional openings in the building envelope to provide fresh air and/or remove exhaust or stale air, without the need for fan power. They are simple and reliable with low first cost and operating cost. They can also be used in combination with fan-powered systems.

Passive ventilation systems alone are generally

## 1. AN OVERVIEW OF VENTILATION RESEARCH AND DEMONSTRATION EFFORTS IN CANADA

---

unable to provide adequate ventilation under small temperature differences or low wind speeds. In some designs, the fresh air entering the space may be uncomfortably cold and supply to certain areas of the home may be inadequate.

Passive ventilation systems will increase the ventilation rate over the case with no intentional openings. Field experiments have demonstrated that fact. Passive exhaust stacks should be as high as possible, with a damper to limit peak flows under large pressure or temperature differences. They are not as effective as mechanical systems at controlling indoor pollutant levels because the ventilation rate is dependent on pressure and temperature differences.

### RECOMMENDATIONS

There remain a number of areas where further research, development or demonstration would fill gaps in knowledge or technology in the ventilation field:

#### Ventilation Requirements

- increasing ventilation rates to control contaminants is ineffective in most cases. Source control is generally the most effective solution and the need exists to develop reliable, low-cost, contaminant sensors;
- there is a need to investigate and quantify the energy savings associated with using dehumidifiers, instead of increasing ventilation levels, as a means of controlling humidity. Ventilation would still be required but perhaps the rates could be lower in homes with dehumidifiers;
- assuming that off-gasing or other contaminants or pollutants could be controlled by other means, such as source control, ventilation rates could be based upon moisture control by the use of a dehumidistat. An investigation should be undertaken to establish whether humidity controlled ventilation is practical and the ideal dehumidistat settings by climate zone and occupancy;
- outdoor make-up air entering a dwelling in winter can be a major source of discomfort to occupants unless pre-heated. Tempering with electric resistance duct heaters during furnace off-cycles is seen as a simple, low-cost solution. However, electric utilities have winter peaks already exacerbated by electric heating. Alternatives need to be investigated which will not contribute to the electric utility peaks demand;
- high inside-wall supply vents are recommended for supply of cool fresh air into the occupied zone. Conventional distribution system design in North America involves floor level supply vents around the perimeter with either low or high inside-wall return grilles. Research needs to be undertaken to establish whether such a distribution system makes sense in Canadian housing or whether a more acceptable alternative exists. How can adequate mixing of warm air during furnace cycles be assured? How effective would cooling operation be with air supplied at this level? These and other questions need to be answered.

#### Ventilation Equipment and Components

- the efficiency of fan-motor sets used in ventilation systems needs to be significantly improved. Regulators may have difficulty mandating continuous mechanical ventilation unless fan power requirements can be reduced. There is a need to establish a reasonable efficiency target, evaluate available energy-efficient fans and undertake research, development and prototype testing of new energy saving fan-motor sets;
- the ineffectiveness of conventional humidity sensors and controls is in many respects responsible for the disappointing performance of today's humidity-controlled ventilation equipment. Accurate, faster response, relatively inexpensive sensors and fan controls need to be developed to improve the potential utility of such systems;
- the use of a motorized-damper in a fresh-air connection to the return system tied to the operation of other exhaust devices might offer an effective solution for a make-up air control. A prototype could be developed and tested to prove the concept;
- in spite of recent project efforts to do the same, there is still a need to investigate and develop a relatively inexpensive indoor-outdoor pressure sensor and control which can be used in a make-up air system;
- Standard CSA-F326, if mandated, would require that ventilation system components, as well as fans, be tested and rated to obtain pressure loss and flow rate characteristics. A test procedure is not specified or referenced in F326. This suggests that a uniform test method

## 1. AN OVERVIEW OF VENTILATION RESEARCH AND DEMONSTRATION EFFORTS IN CANADA

and rating procedure be investigated and prepared in support of CSA-F326 through CSA.

### **Ventilation Systems**

- Humidity-controlled extractor systems warrant further investigation. One system reported in the literature was undersized and the results and conclusions drawn are therefore in question. A properly sized system should be investigated;
- supply-only systems have significant advantages compared to exhaust systems in regard to contaminant control, backdrafting or spillage prevention and improved occupant comfort. There is a need to investigate and establish the range of conditions or circumstances under which supply-only systems may be used without causing damage to the envelope from condensation;
- the claimed savings for the dynamic wall system should be quantified and whether the savings offset the costs associated with reduced insulation effect. Design modifications which could improve the prospects of the dynamic wall should be investigated at the same time;
- the fresh air connection to the return is said to increase the potential for furnace heat exchanger corrosion. In the next few years, the standing pilot will disappear from the marketplace. Its removal should result in a significant reduction, if not complete elimination, of the potential for heat exchanger corrosion problems. The implications of this need to be examined, particularly in relation to the need to provide pre-heat during burner off-cycles.
- the fresh air connection to the return has the disadvantage of no fresh air supply unless the furnace fan operates during burner off-cycles. There is a need to establish a minimum design requirement for an effective, lower operating cost and comfortable air distribution when the furnace fan is off. An investigation should be undertaken to determine how this could be accomplished, with for example the addition of a smaller, fresh air fan in the fresh air supply duct;
- passive ventilation systems offer significant benefits for use in regions with high electricity costs or demand management programs. There is a need to investigate and establish minimum design requirements for combination passive/fan-powered systems to minimize operating costs while improving indoor air quality. The fan-assist would only be used at times of low temperature or pressure differences.



## 2. VENTILATION REQUIREMENTS

### SUMMARY

A dwelling's resistance to air leakage is referred to as airtightness. Airtightness of Canadian homes has increased significantly over the past ten years. Natural air leakage, which is that ventilation that occurs without the assist of a mechanical fan to provide a pressure difference to establish flow, can no longer be relied upon to provide adequate ventilation.

The ventilation requirements depend on whether there is a need for contaminant control or humidity or condensation control. Where ventilation involves exhaust or combustion flows, there may be a requirement to provide make-up air to maintain the dwelling pressure balance and avoid backdraft or flue spillage in homes with vented appliances.

The simple introduction of fresh air into a dwelling is not sufficient by itself to ensure occupant health and comfort. Ventilation/Distribution Effectiveness refers to how well a ventilation system distributes air in adequate quantities to different zones, without causing occupant discomfort problems.

Different Codes and Standards are discussed that set down requirements for ventilation air quantities, methods of supply and system operation, and means of determining compliance.



## 2. VENTILATION REQUIREMENTS

### AIRTIGHTNESS

Space heating energy is lost from buildings by conduction of heat through the walls, floors and ceilings, and air leakage through unintentional openings (cracks and holes) in the building envelope as well as in the operation of mechanical ventilation systems. The resistance to air leakage is determined by the airtightness of the building envelope. Usually airtightness is expressed in terms of equivalent leakage area (ELA) or air changes per hour at 50 Pa (ac/h<sub>50</sub>). ELA is the size, expressed in cm<sup>2</sup>, of all of the holes in the building envelope, described as if they were combined into one single hole.

Over the last ten years, houses have become considerably more airtight than in the past. This has occurred to reduce energy consumption and drafts and thereby improve comfort.

Making a house airtight has some obvious advantages but can lead to some potential problems.

#### Advantages of Increased Airtightness

- Improved building envelope performance
- Reduced energy consumption
- Improved comfort

#### Potential Problems from Air-tightening

- If reduced natural infiltration is not compensated by mechanical ventilation, humidity levels may increase in winter, creating a potential for mould growth and structural damage (rot)
- Depressurization of the house may increase, causing combustion appliances problems in venting the products of combustion
- Air quality may degrade due to pollutant build-up
- Careful installation of the air/vapour barrier is more critical because air leaking out may be at a higher relative humidity.

#### Standard Procedure for Testing Airtightness

Airtight construction is recognized as being an important element in energy efficient housing. In 1979 Beach [7] reported on the measured relative tightness of 60 new houses in the Ottawa area.

The test procedure and data presentation ( $Q=C(\Delta P)^n$ ) employed, formed the basis of standard methods which followed. In the early 1980s, the Canadian General Standards Board (CGSB) completed a standard procedure for testing the airtightness of houses [20], so that reliable, consistent and repeatable measurements could be made. This allowed for the first time, the results of research done by different researchers, in different parts of the country, to be compared. It also provided an opportunity to identify a trend towards increased airtightness in recent years.

#### Airtightness in the Early 1980s

In 1982 and 1983, Sulatisky [74] conducted airtightness tests on 200 new houses across Canada, using a procedure similar to that prescribed by the CGSB Standard. A fan-door was used to test the airtightness of 200 recently constructed houses, province by province, across Canada. At that time, with a few exceptions, only super energy-efficient houses (R2000 houses) were fitted with a continuous air/vapour barrier. It is not clear whether the houses tested were built in accordance with the 1980 National Building Code, some earlier version or a provincial building code.

Fan-door tests showed that in the early 1980s, the tightest new houses were being built in Manitoba and Saskatchewan. These houses did not have a continuous air/vapour barrier, but did have polyethylene-enclosed electrical outlets and fixtures, and caulking at the header-joist connection in a number of houses. Houses located in British Columbia, Alberta, Ontario and Prince Edward Island were not as airtight. Smoke pencils were used in test houses from these four provinces to locate the following major leakage locations:

- the sill to header-joist to wall connections
- the electrical outlets and fixtures
- the utility service and plumbing penetrations of the building envelope
- the frames around windows, doors and attic hatches
- around fireplaces
- around wall overhangs and bay windows.

The tests showed that the average level of airtightness in Canadian housing in the early

## 2. VENTILATION REQUIREMENTS

1980s was equal to that of Swedish houses built after 1965 and equivalent to that of a range of energy-efficient houses constructed in the United States. In Ontario and Quebec, the degree of airtightness of the houses appeared to reflect considerable variation from builder to builder.

The Ontario house sample consisted of 20 houses with 2 mil polyethylene air/vapour barriers and an equal number with 4 mil. The results of the airtightness tests showed that those houses with the 4 mil air/vapour barriers were 22% tighter than those with 2 mil. The use of a thicker 4 mil polyethylene results in a better air barrier than 2 mil. The report surmised that the thicker material is easier to work with and less likely to tear during installation [74].

### Airtightness in 1989

In 1989 a survey [37] of the airtightness of 200 new merchant builder houses was conducted. The CGSB Fan Depressurization method was used, allowing comparisons to be made with the 1982 study discussed above. In addition, the results of the survey were input to a computer program that used weather data for the specific location to predict, on an hourly basis for a typical year, the rate of air leakage each house would experience

under the influence of wind and temperature. The computer program showed which houses without mechanical ventilation were likely to have periods of air leakage below generally accepted minimum levels for health and safety.

The computer generated data predicted that more than 70% of the surveyed houses were so airtight that the air leakage rate during the heating season would be less than the generally recognized minimum acceptable rate of 0.3 ac/h. Almost 90% of the surveyed houses were predicted to have at least one month during the heating season when the average air leakage rate was less than 0.3 ac/h. Virtually all of the surveyed houses (99%) were predicted to have at least one 24 hour period during the heating season over which the average air leakage rate was less than 0.3 ac/h in the absence of mechanical ventilation.

### Airtightness Increases Through the 1980s

In early 1990, Hamlin et al. [35] conducted a literature search on airtightness in Canadian housing. The following is based upon the report that was published in May 1990. Though several studies were reviewed, a major part of this report summarized the two studies discussed above and then went on to make some interesting

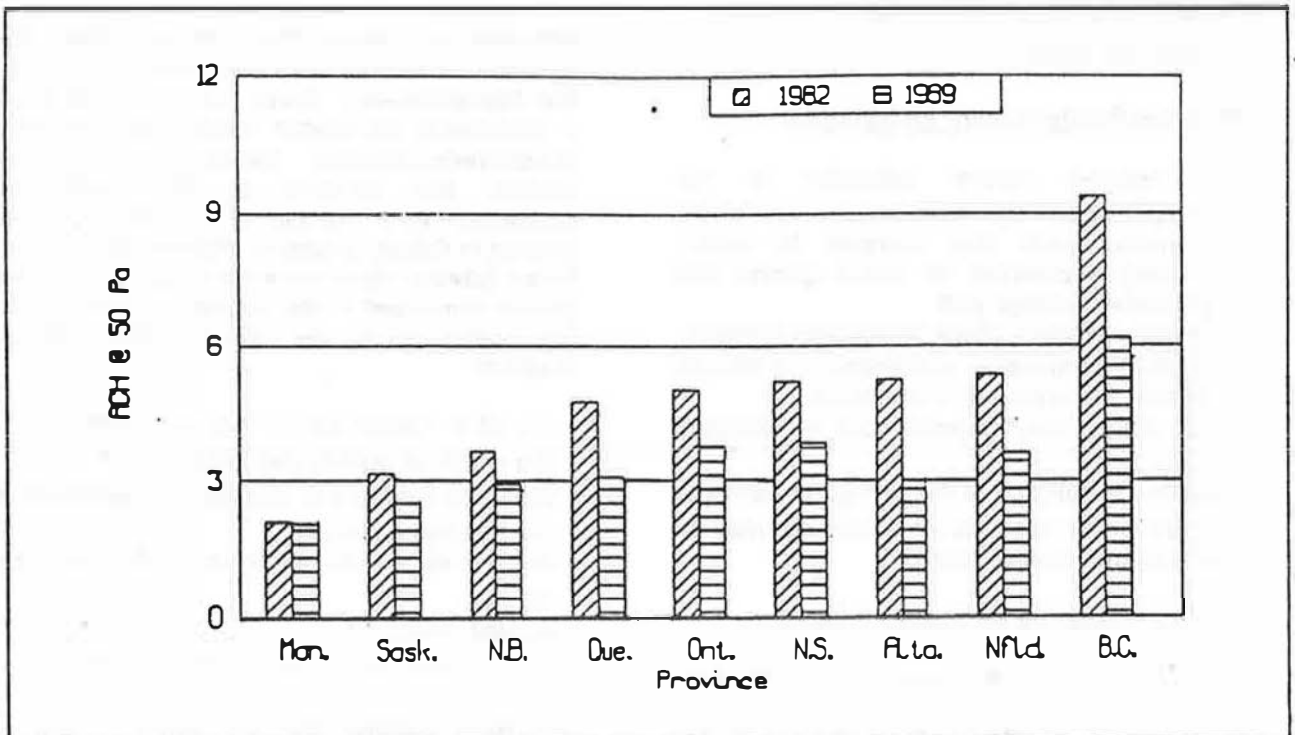

Comparison of Air Change Rates 1982/83 Data versus 1989 Data [35]

## 2. VENTILATION REQUIREMENTS

---

comparisons.

The results of the 1989 study suggested that houses had become 30% tighter than reported in Sulatisky [74]. The most significant improvement had occurred in British Columbia, where the average airtightness improved by almost 40%. Part of the change was attributed to the increased size of the homes being built in Vancouver, as the air leakage at 50 Pa is normalized by house size. New houses built in British Columbia still had the highest rates of air leakage. Houses in the colder regions of the country were found to be more airtight than those located in more temperate areas. The study suggested that this trend is probably influenced by comfort and energy cost concerns.

### Airtightness and Air Quality

Newton [53] states that since most people spend the majority of their time indoors, and since modern building materials tend to outgas, the trend towards reduced air infiltration is making indoor air pollution a greater problem for modern society. The report recognized that the incidence of moisture problems in buildings is increasing as airtightness increases. The potential for backdrafting and flue gas spillage increases with the level of air-tightening of the building envelope. The report quotes D.J. Wilson of the University of Alberta as saying that occupant behaviour tends to increase infiltration rates by about 0.2 ac/h.

The appendix of the report provides a brief summary of documents reviewed during a literature search. One 1981 report by "Applied Energy", on the effects of weather-stripping of doors and windows, indicated that such action can reduce the natural ventilation rate (and therefore increase the airtightness) by one-third.

### **AIR-TIGHTENING EXISTING HOUSING**

Unies [82] evaluated the effectiveness of attempts, by a commercial air leakage control contractor, to

improve the airtightness of existing houses. In a sample of 56 conventional houses, the increased airtightness due to the sealing, as indicated by a reduction in equivalent leakage area at 10 Pa ( $ELA_{10}$ ), was measured. The  $ELA_{10}$  was reduced by 24 to 37% with a median of 32%.

### **DEGRADATION OF AIRTIGHTNESS**

It has been suggested that the airtightness of a house will decrease with time due to deterioration of the polyethylene air-barrier, shrinkage of lumber and settling of the structure. Through observations made on twenty-four houses over periods of up to three years, Proskiw [62] concluded that no evidence was found to indicate that either the polyethylene air barrier or the airtight drywall approach systems were unsuited for use as air barrier materials. Observed changes in airtightness were found to be small and were not judged to be of practical significance.

### **CONCLUSIONS**

In recent years, Canadian houses have become much more airtight [35]. The majority of houses being built in Canada, using normal construction practices, are close enough to being airtight that leakage through the envelope cannot be relied upon to provide, at all times throughout the heating season, the rate of air change that most authorities judge to be necessary to maintain adequate air quality in normal households [37]. To ensure this rate of air change at all times, throughout the heating season, houses must be provided with mechanical ventilation systems [37]. With the exception of air conditioned houses where the windows are kept closed, natural infiltration is at its minimum during the shoulder months, spring and fall in many parts of the country [37]. It was also concluded that it is almost impossible to predict the sizes, shapes and distribution of air paths in building envelopes.

[Faint, illegible text, possibly bleed-through from the reverse side of the page]

## 2. VENTILATION REQUIREMENTS

---

### NATURAL VENTILATION AND INFILTRATION

Until recently, with the exception of intentionally airtight houses, it was assumed that a combination of passive ventilation and infiltration would provide sufficient fresh air to maintain adequate air quality for the occupants of most houses. Research has now shown that even leaky older houses can have inadequate infiltration rates during the shoulder seasons and during the summer air conditioning. Experts generally agree that for houses with normal rates of contaminant generation, at least 0.3 air changes per hour are required to maintain adequate ventilation rates. Even this rate of infiltration will not ensure good indoor air quality, unless the fresh air is adequately distributed to all habitable areas of a house (CSA [19]).

#### NATURAL INFILTRATION

Natural infiltration is defined as the leakage of fresh air into a house through unintentional openings in the envelope. Air flows into and out of a building because of pressure differences between the outdoors and indoors. Pressure differences which cause natural infiltration are produced by wind (high pressure on a windward wall and low pressure on a leeward wall) and the stack effect, caused by indoor/outdoor temperature differences (hot air rises and leaks out of the upper portions of a building and is replaced by cool outdoor air infiltrating into the lower portion). The rate of natural infiltration is determined by the difference in pressure and the size of the openings in the building envelope.

#### PASSIVE VENTILATION

Passive ventilation is defined as the movement of air in and out of a house through intentional openings, such as windows, doors and vents. Air is still moved by the same forces as in passive infiltration, but usually there is lower resistance to air flow requiring less pressure difference. Air exchange by passive ventilation is controlled by the occupant and is not influenced by house airtightness.

#### IMPORTANCE OF NATURAL INFILTRATION

Unless a mechanical ventilation system is present, effective and utilized, natural infiltration is the only

method of diluting indoor air contaminants to acceptable levels and providing the oxygen that the occupants of a house require, when passive openings are closed.

#### MEASURING NATURAL INFILTRATION RATES

Several studies have been conducted to quantify natural infiltration rates. Some studies have used tracer gas decay methods to measure air change rates in houses. Others have attempted to develop correlations between measured tracer gas air change rates and air change rates measured during fan depressurization tests. Others have attempted to construct mathematical models based on wind velocity and direction, and buoyancy or stack effects and to validate these against measured data.

The natural infiltration rate of a house is usually determined by a tracer gas technique, which can be more accurate than modelled results (T.E.S. [75]). The main weakness of tracer gas tests is that the infiltration rate obtained is unique to the weather conditions at the time of the test. Though there are several tracer gas techniques, one of the more commonly used methods is to inject a quantity of a non-toxic tracer gas, such as helium, carbon dioxide or sulphur hexafluoride, into a building space and measure the rate of decay of the gas concentration. After ensuring that the initial quantity of tracer gas is well mixed in the dwelling using the furnace blower, concentration measurements are taken at 5 to 15 minute intervals. The air change, during the test period, is then determined by finding the best-fit exponential decay curve for the concentration decay data.

Mathematical regressions of data from several buildings were performed by Sunton Engineering [53] in an attempt to derive a relationship applicable to other buildings. These studies have invariably met with limited success of the large variances in house construction. This is further complicated by the fact that occupant behaviour can increase infiltration rates by about 0.2 ac/h, according to Wilson, of the Department of Mechanical Engineering of the University of Alberta.

#### TYPICAL NATURAL INFILTRATION RATES

A 1989 study [35] conducted by Hamlin, Forman and Lubun on behalf of CMHC, using a tracer gas method, found that 82% of a sample of 50 new

## 2. VENTILATION REQUIREMENTS

homes across Canada had natural infiltration rates lower than 0.3 ac/h during the late winter/early spring sampling period. According to [35], air change rates greater than 0.3 have a diminishing effect on reducing the concentration levels of some indoor air contaminants. Therefore, 0.3 ac/h may not only be the minimum acceptable level but also the optimum.

Using tracer gas measurements taken in many houses across the country, Handegord [52] calculated that air leakage caused by a 16 km/h wind (without stack effect or the effect of exhaust devices) would vary from 0.01 of an air change per hour in the tightest house measured to 0.1 ac/h in the leakiest. From the same airtightness tests, it was calculated that the stack effect in an average size house would produce an air change rate of 0.006 ac/h in the tightest house and 0.67 ac/h in the leakiest tested. If these houses had a fireplace, the air change rate would increase by 1.3 ac/h per hour and the addition of an oil fired furnace could increase the air change rate by 0.5 ac/h (providing they were able to draw in the amount of air required for proper venting of the combustion products).

The leakiest house in the survey would have provided too much ventilation under wind or stack action but not enough under no-wind, no-stack conditions [52]. Thus making houses leakier provides no guarantee of adequate ventilation at all times.

### PREDICTING NATURAL AIR INFILTRATION RATES

Data from air leakage tests conducted in 200 new Canadian homes in 1989 [37] were input to a NRC computer model (Shaw 1985) which, using hour-by-hour weather data, predicted hourly natural infiltration rates caused by winds and indoor/outdoor temperature differences. Results produced by the model were compared with other models and with results from tracer gas tests of houses. The predictions were found to be a good indicator of the amount of natural infiltration that can be expected to occur in houses which experience weather similar to the input weather data used.

The computer model results showed that:

- More than 70% of the surveyed houses were predicted to have an average air infiltration rate

of less than the 0.3 ac/h (referenced in the 1990 National Building Code of Canada) during the heating season.

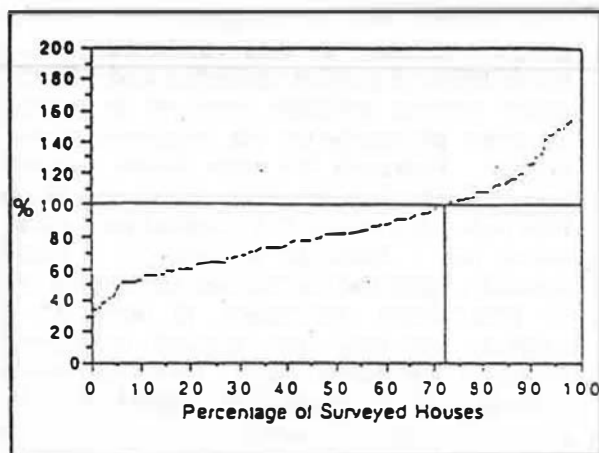

**Seasonal Average Air Leakage Rate as % of 1990 Ventilation Requirement [37]**

- Almost 90% of the surveyed houses were predicted to have at least one month during the heating season when the average air leakage rate is less than 0.3 ac/h.

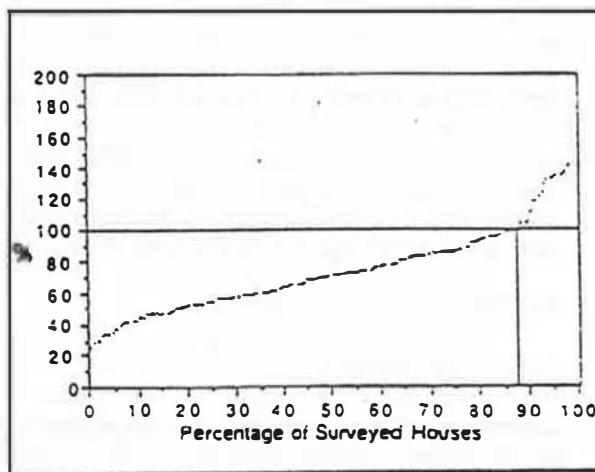

**Minimum Monthly Average Air Leakage Rate as % of 1990 Ventilation Requirement [37]**

- Virtually all of the surveyed houses (99%) were predicted to have an average air leakage rate less than 0.3 ac/h during at least one 24 hour period in the heating season.



## 2. VENTILATION REQUIREMENTS

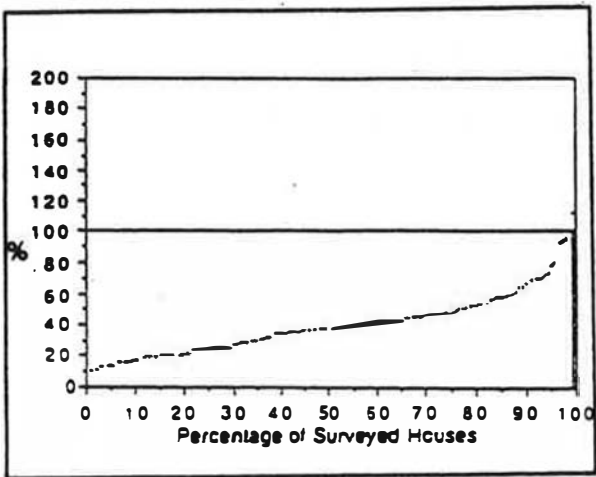

**Minimum 24 Hour Average Air Leakage Rate as % of 1990 Ventilation Requirement [37]**

These results apply to the heating season only, when natural infiltration rates are at their highest due to the stack effect caused by the large indoor/outdoor temperature differences. Natural infiltration rates during the spring and fall are much lower than in winter. When air conditioning is used in the summer, with windows kept closed, infiltration rates may be even lower.

### CONCLUSIONS

Since natural forces cannot be relied upon to provide adequate ventilation rates under all circumstances, a mechanical ventilation system is desirable [52].





## 2. VENTILATION REQUIREMENTS

However, some contaminants would require impractical levels of ventilation to bring concentrations down to an acceptable level, in a smoking environment [75]. (ASHRAE 62-89 [4] now recommends 7.5 L/s per person for non-smoking areas and 30 L/s per person in areas where smoking is permitted.)

Though ventilation is most effective in diluting aerosols, it can in itself introduce air contaminants in the form of particulates from the outdoors (eg. dust, pollen). These particles can be removed from the ventilation air by passing it through a high efficiency air cleaner before introduction to habitable areas of a house. If the inlet location of a ventilation system is poorly located (eg. adjacent to a driveway), the ventilation system can also introduce aerosol contaminants into the space.

Radon and its decay daughters are known to contribute a significant portion of natural background radiation exposure to the general population [75]. The most effective radon control measures are those which prevent entry of the gas into the house from the surrounding soil. For example, Proskiw [63] found that sub-slab depressurization reduced the rate of radon entry by up to 98% where as increased mechanical ventilation was only moderately effective.

Health and Welfare Canada [28] has indicated that air within a residence should be sufficiently free of biological, physical and chemical contaminants to ensure that there is negligible risk to the health and safety of the occupants and to this end has set exposure guidelines. Household exposures are more critical than those in the workplace because people spend longer periods of time at home [28].

Kadulski [44] points out that one big problem with indoor air pollution is that contaminant levels that are intolerable for one may be negligible for the next person. The most common symptoms associated with indoor air quality problems are: eye and/or skin irritation, dry throat, headache, fatigue, sinus congestion, and shortness of breath. Most of the literature on the subject has one common theme: there is insufficient information to know the full extent of health risk from indoor air pollution.

### RECOMMENDED OCCUPANT VENTILATION RATES

Recommended ventilation rates shifted drastically in the 1970s as energy conservation concerns arose. Recommended ASHRAE 62-81 rates were reduced from 7.5 to 2.5 L/s per person for this reason. Mattock and Rousseau [46] state that this action alone is considered by many to be the major factor in the rash of air quality problems experienced in commercial buildings throughout the 1980s.

ASHRAE Standard 62-89 expresses minimum recommended ventilation rates for residential single family dwellings in a different manner than in the past. The rate for living areas is 0.35 ac/h, but not less than 7.5 L/s per occupant. For the purpose of calculating this ventilation rate, it is assumed that there are two occupants for the first bedroom and one for each additional bedroom. It is recommended that the kitchen be provided with an intermittent exhaust capacity of 50 L/s or a continuous exhaust capacity of 25 L/s, or openable windows. Bathrooms should be provided with an intermittent exhaust of 25 L/s, or a continuous exhaust of 10 L/s, or an openable window.

The CSA-F326 [19] minimum overall ventilation air requirement for mechanical ventilation systems is similar (0.3 ac/h vs 0.35 ac/h) to the outdoor air requirements in ASHRAE 62-89, however, the latter standard assumes that in residential facilities "the ventilation is normally satisfied by infiltration and natural ventilation". CSA-F326 also specifies a range of other minimum requirements including the distribution of ventilation air, supply temperatures, systems installation practice, maximum impact on dwelling depressurization etc.

Minimum ventilation rates are often specified only in the form of air changes per hour. Since this specification refers to the building and not the occupancy the required number of air changes per hour may provide inadequate ventilation for a small house and excessive amounts for a large house if the occupancy of both houses is identical. If flow rate is specified, either by number of occupants or by room type and count, the ventilation rate is more likely to meet the occupants needs. Predicting the number of occupants in a home and which spaces they will occupy, at any given time, is difficult. For this reason, methods based upon room type and number of rooms may be preferred [46].

ASHRAE [4] includes a calculation showing that

## 2. VENTILATION REQUIREMENTS

the CO<sub>2</sub> concentration is limited to 1000 ppm, for one adult in very light activity, if 7.0 L/s of ventilation air is supplied. Human CO<sub>2</sub> production rates for a range of other activity levels is also provided.

### VENTILATION RATES FOR CONTAMINANT CONTROL

In the Nordic countries, concern about radon levels has resulted in recommended minimum ventilation rates of 0.5 ac/h. The International Energy Agency has summarized work done on preferences and psychological needs of ventilation as follows\*:

- For moisture removal: 5.6 to 11 L/s per person (depending on climate and other factors)
- For body odour: 8 L/s per person (satisfies 80%

of people)

- For CO<sub>2</sub> control: 4 to 8 L/s per person
- For tobacco smoke control: 8.3 to 19.4 L/s per person
- For volatile organic control: source control is recommended, not dilution by ventilation [53],[92]

\* These values are not additive.

### CONTAMINANT LEVELS IN VENTILATED HOUSES

Dumont [23] measured formaldehyde, radon and nitrogen dioxide concentration in a number of relatively airtight (1.33 ac/h @ 50 Pa average) Saskatoon homes. Elevated levels of

POLLUTANT	SOURCE CONTROL	MOISTURE CONTROL	FILTERING	VENTILATION
FORMALDEHYDE	BEST WAY TO CONTROL FORMALDEHYDE LEVELS	WILL SLOW DOWN RATE OF OFFGASSING BUT EXTEND THE LENGTH OF TIME TO COMPLETE OFFGASSING	NO EFFECT	INCREASES RATE OF OFFGASSING (RAISING CONCENTRATION OF FORMALDEHYDE) BUT SHORTENS THE LENGTH OF TIME TO COMPLETE OFFGASSING
TOBACCO BY-PRODUCTS	BEST SOLUTION	NO EFFECT	PARTIAL SOLUTION BY TRAPPING PARTICLES (ESPECIALLY GOOD IN FORCED AIR HEATING SYSTEMS)	EXPENSIVE AS VERY HIGH VOLUMES OF AIR ARE REQUIRED
RADON	BEST SOLUTION IS TO KEEP RADON OUT OF THE HOUSE	NO EFFECT	REDUCES PARTICLE CONCENTRATIONS	PARTIAL AT BEST
MOISTURE (BULK & GROUND)	CONTROL OF GROUND MOISTURE & OTHER BULK WATER SOURCES	AT SOURCE	NO EFFECT	WILL REDUCE HUMIDITY LEVELS
MOISTURE (OCCUPANT GENERATED)	NOT PRACTICAL		NO EFFECT	BEST SOLUTION
COMBUSTION BY-PRODUCTS	BEST SOLUTION INDUCED DRAFT OR SEALED COMBUSTION APPLIANCES	NO EFFECT	NO EFFECT	NOT DESIRABLE OR SAFE
MICROBES	LIMITED EFFECT	LOW HUMIDITY IS POOR ENVIRONMENT FOR GROWTH	LIMITED EFFECT	REDUCED HUMIDITY POOR ENVIRONMENT FOR GROWTH
CO, CO <sub>2</sub> , (OCCUPANTS)	NO EFFECT		NO EFFECT	BEST SOLUTION
PARTICULATES	BEST SOLUTION		VERY GOOD WITH APPROPRIATE FILTERS	NO EFFECT

Control Strategies for Various Pollutant Types [44]

## 2. VENTILATION REQUIREMENTS

---

formaldehyde (>0.1 ppm, ASHRAE 62-1981 Guideline) were found in 18 of 46 houses. Radon levels exceeded the USEPA guideline (4.0 pCi/L) in 12 of 44 houses. No homes with elevated levels of nitrogen dioxide were found. These houses without mechanical ventilation systems had consistently higher incidence of elevated formaldehyde concentrations compared to homes incorporating such systems. Of the houses with no mechanical ventilation, 50% had formaldehyde levels greater than the guideline. Only 27% with mechanical ventilation systems had formaldehyde levels above the guideline. The formaldehyde off-gassing rate is known to increase with higher humidity, more likely to be found in under-ventilated homes. This study showed that mechanically-ventilated houses usually have better indoor air quality than non mechanically-ventilated houses, when the ventilation system is operating, but that ventilation alone will not ensure satisfactory air contaminant levels.

Proskiw [61] found that the air quality in R2000 was superior to that in conventional structures when concentrations of several different pollutants were examined over a multi-year monitoring period. The same study determined that statistical correlations between pollutant concentrations and total air change rates were generally poor, and concluded that greater emphasis should be placed on other contaminant control measures.

It has often been said that high indoor humidity is an indication of generally unacceptable air quality.

A study conducted in northern homes by Ferguson, Simek and Clark [31] found no correlation between humidity and indoor air quality as measured by CO<sub>2</sub> concentration. This may indicate that the use of humidistat control of a ventilation system cannot ensure adequate indoor air quality.

### RECOMMENDATIONS

Remedial work should be undertaken in houses where pollutant levels exceed guidelines or standards. Further work should be done on identifying pollutant sources in houses and in determining their strength.

Indoor air quality in Canadian houses can be maintained at acceptable levels through a multi-pronged approach:

- Reduce the number of contaminant causing products and building materials in a house.
- Provide adequate ventilation to control CO<sub>2</sub> levels, humidity and odours.
- Remove particulate pollutants through air filtering.
- Remove pollutants at the source.
- Adequately distribute ventilation air.
- Provide greater intermittent ventilation rates for occasional and temporary indoor air quality problems.
- Utilize reliable, low cost air contaminant sensors and control systems, when they become available.

## 2. VENTILATION REQUIREMENTS

### HUMIDITY AND CONDENSATION CONTROL

The last decade has seen new houses built in Canada become much more airtight. This increase in airtightness has resulted in a significant reduction of natural air leakage in houses. In the absence of natural or mechanical ventilation, tight houses can trap moisture laden air within the envelope in winter when houses are closed-up. Often there is insufficient air changes to control the moisture content of the indoor air. High indoor humidity levels, especially in winter, are undesirable for health reasons and can accelerate degradation of components of the wall cavity. Building codes have been attempting to address the problem especially through mechanical ventilation requirements.

The amount of moisture that can be held by air is a function of its temperature. The higher the temperature, the more moisture the air can hold. At any specific temperature there is a maximum amount that can be supported. Generally, water vapour in the air is expressed as "relative humidity"(RH). This is the ratio or percent of the amount of water vapour in the air related to the maximum amount of water vapour it can support

at that particular temperature. If the RH of the air is 100% and the air is cooled, water will be precipitated out in the form of condensation if there is a cool surface available. This temperature below which the air can no longer hold its moisture content is called the dew point. As the air temperature drops below the dew point, more water will be released. Very little water vapour can be supported by air at a temperature below the freezing point of water.

### ACCEPTABLE HUMIDITY LEVELS

There are both upper and lower bounds to what is considered an acceptable humidity level [88]. For health reasons, the RH level should be between 25 and 50%, with levels closer to the latter preferred [88]. ASHRAE recommends RH levels of 40% to 60% for health considerations. Health and Welfare guidelines recommend 30-50% in winter as reported by Habitat Design & Consulting [46]. For the purpose of preventing condensation on cool surfaces and mould growth in the winter time, the RH may have to be maintained at a lower level (30-35% in mid-winter with double glazing and 40% with triple glazing NRC [52]). Indoor RH above 50% is said to enhance the spread of viral infections. The RH level required to prevent condensation problems

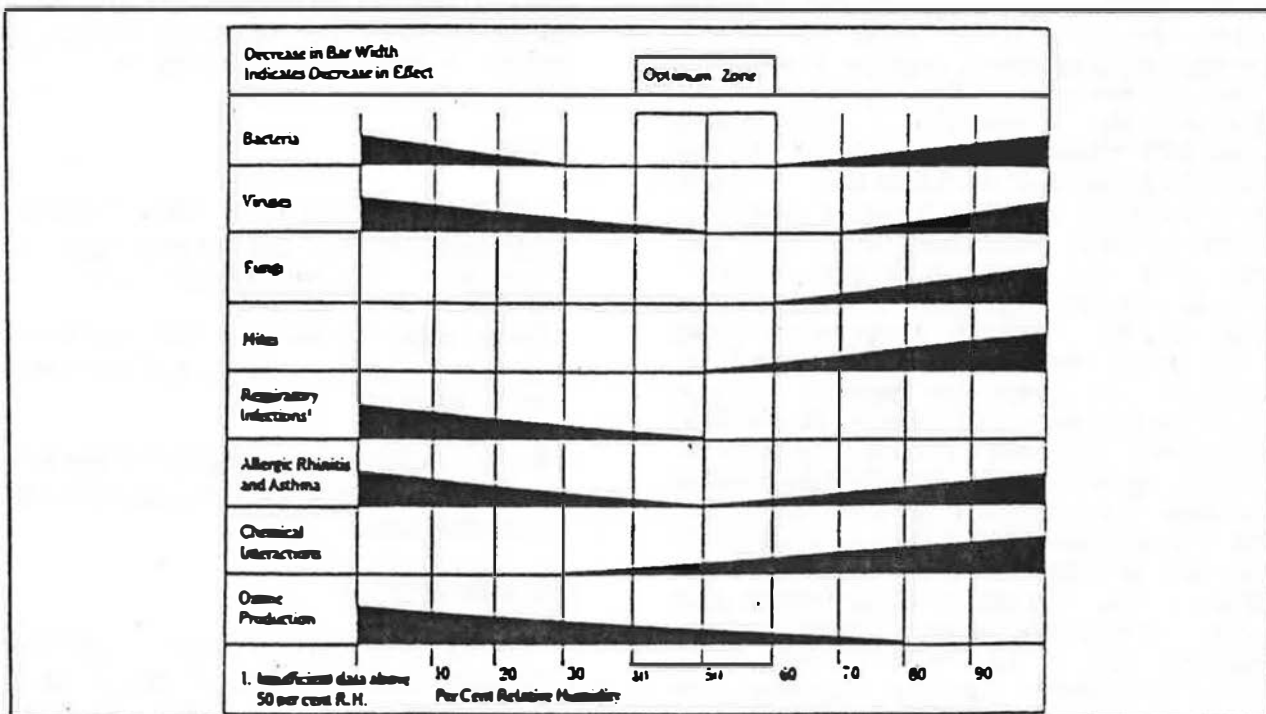

Humidity and Health Effects [57]

## 2. VENTILATION REQUIREMENTS

varies, depending upon air movement and the temperature of cool surfaces such as exterior walls and windows [88].

### IMPORTANCE OF HUMIDITY AND CONDENSATION CONTROL

It is well documented that the combination of high indoor relative humidity and low wall surface temperatures contribute to mould growth on exterior walls and ceilings. Habitat Design & Consulting [46] reported that high humidity levels also lead to increases in dust mites and prolonged survival of bacteria and viruses while very low humidity is associated with dryness of skin and irritation of mucous membranes.

The combination of humid air and air movement through the house envelope to the outdoors can cause condensation problems in the structure. As warm moist air moves through the envelope to the outside, it cools. When it cools below the dew point, moisture condenses onto adjacent surfaces (in wall cavities or the attic). Usually the condensation occurs in the insulation or on the wood frame. If the moisture fails to dry quickly, mould growth and rotting may commence, potentially leading to structural failure.

A study conducted in 1982 by Marshall, Macklin, Monaghan Ltd. [85] for CMHC showed that moisture-troubled homes displayed a number of significant common features. For the most part, they were newly constructed, attached housing units with moderate to high levels of insulation and airtightness and no active flue. Of these, 81% had baseboard electric heating, while most of the remainder were heated with airtight wood stoves. A high proportion of these moisture-troubled homes were found in the Maritimes, especially Newfoundland. It was estimated that 1.5% of the total National Housing Act (NHA) housing stock constructed between 1973 and 1981 had moisture problems. According to NRC [52], twenty-one percent of Newfoundland homes built during that same period suffer from moisture damage. It was reported [52] that there were at least 10,000 housing units in Canada which had moisture problems serious enough to cause financial loss. The report did not indicate what portion of these houses were suffering moisture damage due to climatic conditions, poorly designed ventilation systems or a combination of both factors.

### SOURCES OF MOISTURE IN CANADIAN HOUSES

It is estimated by White [88] that a typical family of four generates from 10 to 20 litres of moisture per day, though this has not been validated. Sunton's report [53] puts the level of moisture generation for a family of four at 23 litres per day. The actual rates will vary with season and with occupant lifestyle.

Ontario Hydro reported [57] that when a house is new, there is a lot of moisture input from construction materials, typically 20 litres per day during the first year, 15 litres per day during the second and 10 litres per day during the third and subsequent years. NRC [52] identified the major sources of this moisture during the first few years as the framing lumber, which is usually quite wet, and the concrete basement foundation. It is estimated that in a typical two storey house, the drying of the framing lumber can release over 200 litres of water into the house. Concrete used in the foundation can release over 2000 litres of moisture during the first two years, most of it during the first year [52].

### FACTORS THAT AFFECT HUMIDITY LEVELS

Marshall, Macklin, Monaghan Ltd. [85] found several factors that contributed significantly to the severity of moisture-related problems in NHA housing. These included:

#### Climate

- Windy, cool and very wet climate, especially in the spring, that extended the time required for moisture in the house envelope to dry.
- Condensation on windows that can lead to damage to window frames and the drywall below windows.
- Extended cold periods coupled with low levels of sunshine, leading to high moisture content in exterior walls.

#### Moisture Generation

- High levels of interior moisture generation because of occupancy and lifestyle factors (showers, dish washing, cooking, humidifiers, plants, etc) ground water, cracks in basement, and age of house.



## 2. VENTILATION REQUIREMENTS

### CONTROL THROUGH DESIGN AND CONSTRUCTION TECHNIQUES

An air barrier can play an important role in controlling moisture damage. There is a higher incidence of moisture damage in walls of the second floor of a two story building, likely due to the stack effect (fresh air infiltrates into the lower level of the house and moist indoor air exfiltrates through openings in the upper level). Moisture damage in walls usually occurs in close proximity to the leakage area, such as electrical receptacles. Moisture damage in the attic often results from moist indoor air leaking into the attic area and condensing on the roof members, freezing and accumulating there. Later, when the weather warms, the ice melts and drips down upon the ceiling insulation. This can cause the drywall to become soft and collapse or may cause the trusses to rot.

In climatic regions with long periods of cool wet weather, specific building designs must be used and care must be taken with some fine details of construction to reduce the possibility of moisture problems [85].

### CONTROL THROUGH VENTILATION

The following section refers to houses with low to moderate humidity (normal) sources. It may not be applicable to houses with large moisture sources (eg. damp basements, many plants, hot tubs, etc).

The rate of mechanical ventilation required to control humidity levels is dependent upon the outdoor temperature, and indoor and outdoor RH. High indoor humidity is especially noticeable when windows are coldest. Since there is little moisture held in cold outdoor air, little is drawn in with the ventilation air. There is, therefore, not much difference between the ventilation rate required if the outdoor air has a high or low relative humidity during very cold weather conditions [88].

As the outside air warms up, so do inner window surfaces. The ventilation rate required to prevent window condensation is reduced, reaching a minimum at an outside air temperature of approximately -3 C, if the outside relative humidity is 100%. For lower outdoor relative humidity, the minimum ventilation rate drops and occurs at a higher temperature. If the outside relative humidity is approximately 40% or less,

there is no minimum except where the outside and inside temperatures are equal.

If the outdoor relative humidity remains constant as the outdoor temperature rises above the point where the minimum rate is found, the required ventilation rate will also increase [88]. The increase in the amount of moisture brought in by the outside air overwhelms the effect of the warmer inner window surface. As the temperature of the fully saturated outside air approaches the inside temperature, very large flow rates are required because so much moisture is brought in from the outdoors.

Ventilation for humidity control will be least effective in the fall, because the drying capacity of the outside air is at a minimum and the moisture supply from the occupants is augmented by the moisture coming out of the building material and furnishings, after being stored there during the humid conditions of summer [52].

In Toronto, based upon average daily conditions for January, 1.04 L of moisture per hour would be removed with a ventilation rate of 75 L/s. For a typical family of four, such an exhaust rate would be capable of controlling the humidity to a level below 30% [52]. Sunton Engineering showed that the ventilation rate to prevent condensation on the windows of a 478 m<sup>3</sup> house would be: 1.02 ac/h for single glazing; 0.3 ac/h for double glazing; and 0.2 ac/h for triple glazing [53]. White [88] says that at reasonably high moisture generation rates (20 L/day), air change rates need to exceed 0.25 ac/h to avoid condensation occurring on double glazed windows. For most outdoor temperatures and humidities the rate was less than 0.14 ac/h. These rates are below those presently recommended for general air quality control. This may mean that if visible condensation is occurring on double glazed windows, the ventilation rate is much too low to ensure acceptable air quality.

Air change rates required for ventilation control are unusually high in coastal areas where high RH is combined with relatively high outdoor air temperatures (for much of the heating season). The use of ventilation to control RH is less effective as the outdoor temperature increases according to CMHC [14]. A dehumidifier may be a useful option if house temperatures are adequately high to permit its efficient operation. Along with adequate ventilation, CMHC [14] claimed it is necessary to provide good air

## 2. VENTILATION REQUIREMENTS

---

circulation within the dwelling to prevent pockets of air with a relatively high RH from forming.

Controlling RH through ventilation can in itself cause or enhance moisture problems if not done properly. Use of a positive ventilation system may force moisture-laden air into the structure where the moisture will condense and possibly cause structural damage. On the other hand, use of a negative pressure ventilation system may draw cold air in through the structure, cooling internal surfaces sufficiently to cause surface condensation [52].

Ventilation systems intended to control RH levels in a house are usually operated in either continuous mode, manually or controlled by a dehumidistat. Buchan, Lawton, Parent [11] found that many commercially available dehumidistats are not very accurate. They are, however, capable of cutting the peaks off high humidity levels. They tend not to be very good at controlling the average RH level, though this is not as important as peak control as that is the time when dew point conditions are more likely to occur. Dehumidistats are most effective when located near moisture sources. If dehumidistats were more reliable, they would be more effective in controlling RH levels when combined with the use of ventilation fans.

### ENERGY IMPLICATIONS OF HUMIDITY CONTROL

Though humidity levels can be reduced through source control and the use of dehumidifiers (they

are effective only when the RH levels are above 40% according to one report [52] and 50% according to T.E.S. Limited [75]), the most effective control in regions where the outdoor RH is low is through ventilation [88]. The energy used to power a dehumidifier is not lost, but can provide the house with a form of space heating, except for that energy which is lost in the condensate that goes down the drain.

Controlling RH through the use of ventilation consumes energy because of the necessity of heating the incoming cold air [88]. At warmer temperatures, when outdoor RH humidity is in excess of 60%, it becomes impossible to maintain the desired 50% level through the use of ventilation alone. For most conditions, the energy required to remove moisture by ventilation is in the 2 to 3 kWh/litre range. This may be much more energy than that required to operate a dehumidifier during the heating season, when the energy used to operate the dehumidifier provides heat for space heating. If energy costs are about \$0.05/kWh, the cost of energy to remove 10 litres per day for a 200 day heating season, would be in the \$200 to \$300 range. For most locations in Canada, the cost would be closer to \$200. The energy needed to ventilate a house by mechanical means is in addition to this cost. Because of the efficiency of the motor/fan combinations typically used in housing ventilation systems, the mechanical ventilation costs are greater than necessary [88]. If a fan using 60 watts of power was used, the heating season electrical energy use would be about 1 GJ, and would cost about \$15.

## 2. VENTILATION REQUIREMENTS

### MAKE-UP AIR REQUIREMENTS

Make-up air is air that is introduced to a building through the use of either an intentional passive opening or a powered fan, to replace air that is being exhausted from that building through either an intentional passive opening or a powered fan. The purpose of make-up air is for ventilation and/or to reduce or eliminate the negative pressure caused within the building by exhaust air devices. Passive make-up air inlets utilize the pressure difference between outdoors and indoors created by exhaust devices. This pressure difference induces the flow of outdoor air into the building.

Passive inlets can never completely reduce building pressures to zero at the level of the inlet because they require some negative pressure differential to function. Since the pressure differences between indoors and out is relatively small, large openings may be required to provide sufficient make-up air. Powered make-up air fans can introduce enough air to replace that being exhausted, so that a neutral pressure balance is maintained, however, care must be taken in selecting such fans as they can, if not sized appropriately, introduce more air to the building than is being exhausted, thus pressurizing the building.

### THE IMPORTANCE AND SIGNIFICANCE OF MAKE-UP AIR

Make-up air is important. Without it, exhaust devices could create sufficient negative pressure differentials in some houses to prevent combustion appliances (eg, furnaces) and fireplaces from venting the products of combustion. Negative pressure can induce the entrance of radon or sewer gas into the building. The tighter the house envelope, unless there are no susceptible combustion appliances or soil gas problems, the more important that a make-up air supply be provided, as natural air infiltration may not be sufficient to maintain acceptable pressure levels within a house. Naturally-aspirated combustion appliances do not compete well against powered exhaust devices. Most exhaust fans will nearly always win, according to CMHC [14], unless adequate make-up air is supplied.

### MAKE-UP AIR REQUIREMENTS

The amount of make-up air required depends upon the maximum level of depressurization that is acceptable, the tightness of the building envelope and the amount of air being exhausted.

A recent survey by Hamlin, Forman and Lubin [35] found that:

Device	Free Flows (L/s)	Stall Pressure (Pa)
Furnace/chimney	25	25
Hot water heater/chimney	10	10
Fireplace — burning	110	40
— smouldering	varies	3
Kitchen range hood	70	50
Indoor barbecue fan	120	300
Bathroom exhaust fans	20	30
Clothes dryer	65	70

Typical Flows and Stall Pressures [35]

## 2. VENTILATION REQUIREMENTS

- more than 95% of new houses have clothes dryers
- more than 70% of new houses have bathroom fans or kitchen range hood fans
- more than 50% of new homes utilized fuel-fired heating systems
- approximately 40% of new homes contain fireplaces and
- approximately 30% of new houses have central vacuum systems.

Based upon this information, it is reasonable to assume that a typical new home will contain the minimum of a clothes dryer and a bathroom or

kitchen fan. These exhaust devices, operating in combination, will provide an average air flow of approximately 110 L/s. Hamlin et al [35] suggest that some houses can be depressurized 5 Pa during operation of these fans. This is a logical limit of depressurization because above this chimneys will have trouble establishing sufficient draft to vent the products of combustion. If there is also a central vacuum in the house, the total exhaust flow rate may increase to between 80 and 140 L/s. The operation of a fireplace may cause the exhaust flow rate to rise to between 225 and 285 L/s. The amount of depressurization these exhaust devices will produce is proportional to the leakiness of the envelope [35].

<u>Location</u>	<u>Number of Houses</u>	<u>Average</u>	<u>Air Flow Minimum</u>	<u>Air Flow Maximum</u>
Quebec City	20	62.3	39.1	161.1
Winnipeg	20	69.0	30.5	156.4
Montreal	20	74.2	31.7	128.1
Regina	10	89.0	41.2	131.9
Saskatoon	10	102.7	64.7	141.6
Halifax	12	109.2	39.2	256.5
Fredericton	10	104.0	60.4	162.6
Edmonton	10	119.0	61.3	212.9
St. John's	10	120.6	70.1	197.6
Ottawa	20	168.9	89.4	238.4
Toronto	30	178.7	81.9	315.8
Vancouver	20	221.3	97.5	338.5
<b>Canada</b>	<b>192</b>	<b>123.5</b>	<b>30.5</b>	<b>338.5</b>

**Air Required (L/s) to Depressurize New Houses to 5 Pa [35]**

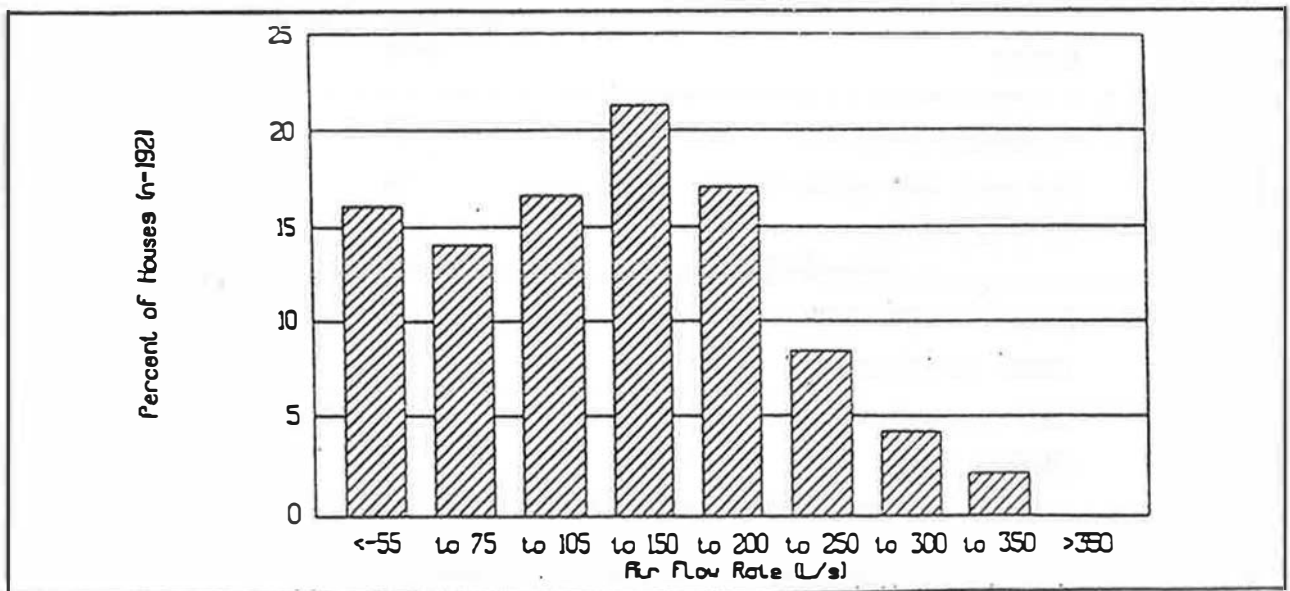

**Air Flow Rates Required to Create 5 Pa Depressurization [35]**

## 2. VENTILATION REQUIREMENTS

Depressurization to 5 Pa at start-up may lead to combustion spillage if naturally aspirated, fuel-fired heating appliances are used in the house. Depending on the airtightness of the house, exhaust air flow rates of between 30.5 L/s and 338.5 L/s were found to be capable of creating a negative pressure of 5 Pa or greater. The table below, from [35], shows the minimum and maximum flow rates which were found, on average, during a 200 house survey, to create negative pressures of 5 Pa or greater, for houses tested in several Canadian cities.

The results shown in the second table were combined with other data to determine the probability of houses having a ventilation capacity which could depressurize a house by 5 Pa. The results are displayed in the following graph.

These results suggest that if a typical house has an installed exhaust fan capacity of 55 L/s and a clothes dryer that achieves 55 L/s air flow, for a potential exhaust capacity of 110 L/s, almost 50% of the houses reported in [35] would be depressurized to 5 Pa or greater by this exhaust air flow rate. In the past, most Canadian homes did not have the problem because exhaust fans did not operate well. Currently there is pressure (NBC 1990, etc) to ensure that fans will operate properly.

In addition to the make-up air requirements of exhaust fans and appliances, combustion appliances also require air for combustion and dilution. For example, Howell-Mayhew Engineering [38] predict that a typical Alberta home with a 34 kW input gas furnace and a 14 kW input hot water heater would require 23 L/s of combustion air.

### SIZE OF MAKE-UP AIR OPENINGS

Habitat Design & Consulting [46] suggest that because the leakage area of a house is not usually known, natural air leakage through unintended openings is often disregarded as a factor when sizing make-up air openings. When natural leakage is disregarded, the make-up air opening or fan must be sized in accordance with the exhaust flow rates anticipated. The limit of acceptable depressurization specified by CSA-F326 [19] is 5 Pa in the presence of naturally aspirated appliances, unless the limit specified by the manufacturer is greater, and 10 Pa where such appliances are not present.

The sizing of make-up air openings should provide for the basic exhaust capacity of the house ventilation system, as well as special requirements for supplying replacement air for large exhaust fans or appliances [46]. In practice, it is usually the large capacity exhaust units, such as downdraft and open fireplaces, that cause excess depressurization [46].

### Make-up Air Flow Through Ducts of 20M Equivalent Length (L/s) BLP [13]

Duct Size (mm)	Pressure Difference	
	5 Pa	10 Pa
75	<5	5
100	8	11
125	15	22
150	25	35
175	40	50
200	55	75
225	80	110
250	100	140

### METHODS OF PROVIDING MAKE-UP AIR

Make-up air can be provided by either a passive opening or a fan. Passive openings are usually connected to some sort of duct system, so that the make-up air can be distributed. Usually an outside hood is provided to protect the opening from the weather and a rodent screen is ordinarily included. This hood and screen add resistance to air flow and must be taken into consideration when sizing the make-up air system. If a duct is attached to the opening, it should be insulated and covered with a polyethylene vapour barrier to prevent condensation. Make-up air provided by a fan and a duct heater should minimize occupant discomfort according to Buchan, Lawton and Parent [13]. Some method of interlinking the fan with exhaust device(s) may also be necessary [13]. Flow control may also be necessary to minimize the impact on heating costs [13] and the potential to excessively pressurize the house must be considered and addressed. BLP [13] developed and tested a prototype pressure control which will be described in "Make-Up Air Devices".

### TEMPERING MAKE-UP AIR

As mentioned, make-up air entering dwellings in winter can be a major source of discomfort unless

## 2. VENTILATION REQUIREMENTS

---

it is pre-heated before entering the occupied zone [13],[46]. Tempering of outside air is necessary for comfort in most, if not all, climates. Tempering can be achieved by preheating with an air-to-air heat exchanger or heat recovery ventilator (HRV), central furnace, fan/duct heater or a combination of these, or it can be done by introducing outdoor air where it will mix with heated air before entering the occupied zone. Of all the methods used, tempering with a furnace or an HRV are the most widely used. Tempering by mixing using high wall entry slots is also in use

but is generally limited to milder climates. Fan/duct heater assemblies could be a popular means of tempering and many are used to preheat or defrost in conjunction with HRVs, but electrical duct heaters must be used in conjunction with an interlocked fan [13]. Hot water loops mounted in make-up air ducts are in use in some applications and are supplied by a central boiler or domestic hot water heater, but could be prone to freezing problems in cold climates [13],[46].

### VENTILATION / DISTRIBUTION EFFECTIVENESS

It is generally recognized by building scientists that airtight houses require a fresh air ventilation system for health and comfort. However, the simple introduction of fresh air into a house will not ensure that the indoor air quality will be adequate in all occupied rooms or spaces. Just as important as introducing the fresh air is its distribution throughout the house and each room within the house. The distribution system should ensure that there is both adequate distribution of fresh air and that the introduction of such air does not cause comfort problems, especially during the winter season.

### RECOMMENDED VENTILATION RATES

Codes and standards have generally recommended continuous ventilation rates of between 0.3 ac/h and 0.5 ac/h for residences. More recently, the importance of the distribution of ventilation air and the need to express the required ventilation rate on a room by room basis has become recognized. According to CSA-F326 [19] each type of room has a minimum acceptable fresh air supply requirement; 5 L/s for all rooms except the basement and the master bedroom. For rooms with high contaminant generation, such as kitchens and bathrooms, there is both a minimum intermittent and a continuous exhaust rate requirement (50/30 L/s for kitchens and 25/10 L/s for bathrooms). Room by room ventilation requirements such as this are usually met through the use of a ventilation distribution system. This ventilation system must be designed to operate continuously.

### DISTRIBUTION OF VENTILATION AIR THROUGHOUT THE WHOLE HOUSE

Ventilation air can be distributed throughout a house by either its own dedicated duct system, as in baseboard electrically heated homes, or through the heating/cooling system duct work, Jones [43], BLP [12]. Caneta Research [21] reported that while the heating/cooling duct system may not deliver the desired proportion of fresh air to each room, because of duct leakage and the fact the primary design criteria was to provide adequate heating, it does provide substantial mixing of the house air, thus diluting contaminant concentrations in source areas. The

forced air heating/cooling system mixes air from all rooms, potentially improving ventilation effectiveness by increasing the air change available in any room served by ducts. However, as cautioned by Habitat Design & Consulting [46], if the forced air system is set to run continuously, the supply outlet locations that are suitable for heating may not be suitable for ventilation air delivery, particularly during the furnace off cycle, because of the low temperature of the air supplied during the winter season. A balanced ventilation system that both supplies ventilation air and removes an equal amount of stale air is most effective according to both Sunton Engineering [53] and Caneta Research [21].

The use of a fresh air distribution system also provides an opportunity for air filtering as shown by Solplan [44]. In addition to indoor generated particulates, fresh air may have high particulate levels during certain seasons. A high efficiency filtration system can remove most of these.

For electric baseboard heated houses, Caneta Research [21] found that the addition of a limited fresh air distribution system, employing small diameter ducts, operated in conjunction with upgraded bathroom and kitchen range-hood fans, appears to provide adequate fresh air distribution. Ideally, such a system would have a supply outlet in each room, however, Caneta Research [21] showed that in a relatively open house design, even a small number of strategically located supply outlets, when used in conjunction with the bathroom and kitchen exhaust fans, could provide acceptable indoor air quality. In homes where there are a limited number of air supply and exhaust points, and fresh air supply outlets are not provided for each room, the air path through the whole house is an important concern. The most effective ventilation strategy in this situation is to supply air at one extreme region in the home and to exhaust it from another. If exhaust points are located in rooms such as bathrooms and kitchens with high contaminant generation, overall ventilation effectiveness is enhanced [46]. Mechanical ventilation systems are not without disadvantages, perhaps the most significant being that it can be, and often is, turned off by the occupants. This is usually due to noise or comfort problems created by a poorly designed and installed system.

## 2. VENTILATION REQUIREMENTS

### DISTRIBUTION OF VENTILATION AIR WITHIN A SINGLE SPACE/ROOM

Diffuser arrangements which allow air to move through a room, without mixing in the occupied zone, are prone to short circuiting, from supply to return, and are less effective [44],[46]. The critical region for ventilation in a room is the zone extending from about 75 mm above the floor to about 1800 mm. Complete mixing of ventilation air in this zone is most important for comfort and ventilation effectiveness. Comfort problems will occur if cool fresh air is introduced into the room either at or below this zone. For this reason, high inside wall supply vents are usually recommended [46]. Cool fresh air introduced at this high level can mix with warm room air before entering the occupied zone. See Figure below for examples of effective and ineffective methods of introducing cool fresh air into a room.

In most cases, ventilation air is not supplied and exhausted from each room in a house. If ventilation air is supplied to each room, it is

usually left to find its way back to the exhaust point, with the path often interrupted by doors. Some means of allowing ventilation air to pass through closed doors is necessary, either by undercutting the door or by installing a grille in the door.

Floor supply outlets for fresh air should not be used when a continuous supply of cold air is to be delivered during the winter season, unless that air is tempered in some manner before delivery. Otherwise, cool ventilation air introduced to a room in this manner, according to Habitat Design & Consulting Ltd. [46], can pool near the floor and may travel across the floor and exit under or through a door without mixing with the air in the occupied zone. At the point where ventilation air is supplied to a habitable space, White [86] states that it should be tempered and diffused so as to avoid creating a sensation of draft, during both the heating and cooling seasons, in any occupied space.

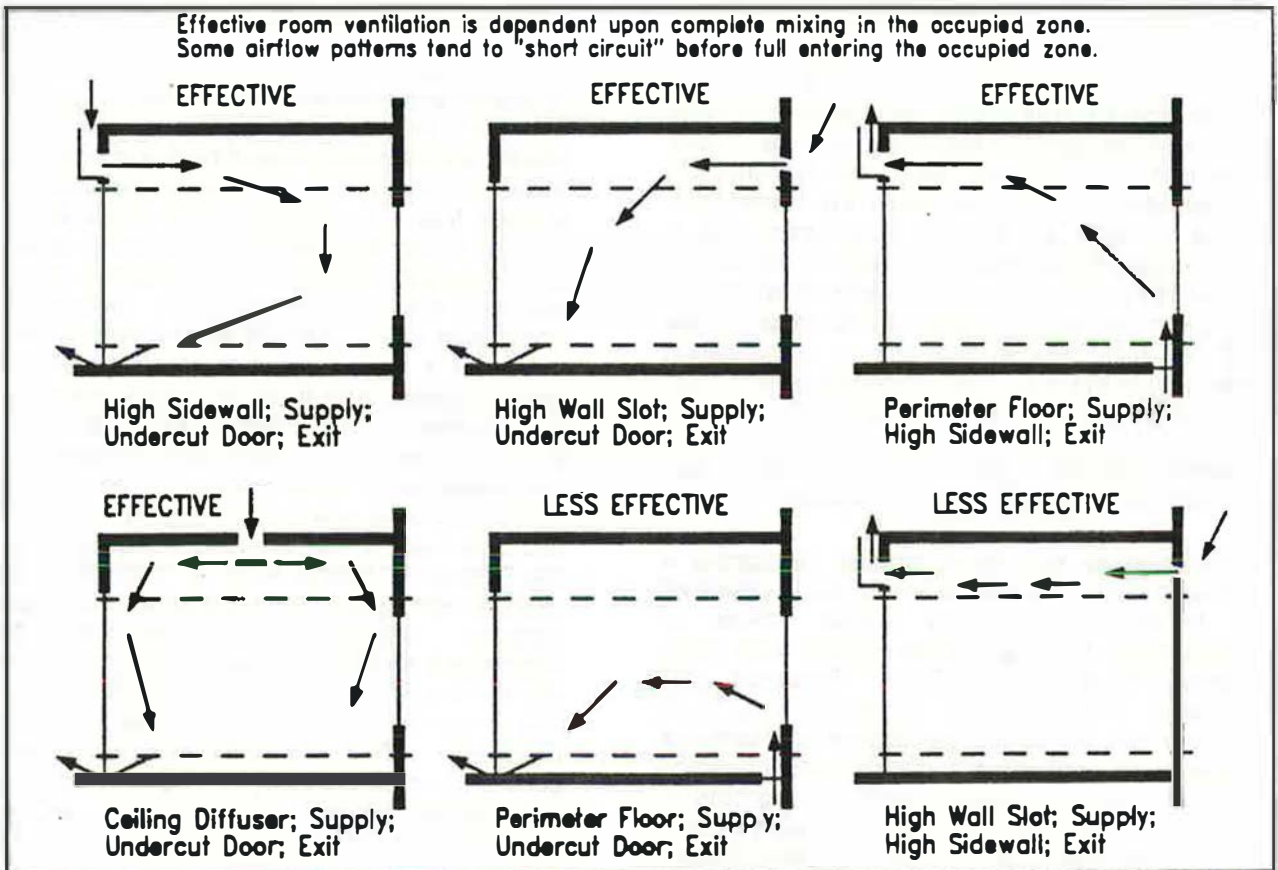



## 2. VENTILATION REQUIREMENTS

### CODES AND STANDARDS

Indoor air quality has become a major concern of building scientists and regulatory authorities in Canada and many other countries. As a result of this concern, there are now many codes and standards that address the issue of fresh air ventilation. Standards may not be mandatory, they usually serve as guidelines or models for possible adoption or inclusion into legislated codes that regulate housing construction. They can provide detailed and prescriptive requirements that would be too lengthy to include in a comprehensive building code. However, Codes can simply reference a standard. Sometimes codes will directly adopt portions of a standard to fulfil a specific need.

The National Building Code of Canada is a model code, available for adoption by the provinces. While most provinces adopt the National Building Code, several modify it to suit real or perceived special local conditions or needs. The National Building Code's ventilation requirements have been significantly modified by several provinces in recent years.

### VENTILATION STANDARDS

There are several ways of specifying ventilation requirements. In recent years there has been a move away from specifying a simple building air change per hour rate (ac/h) in Canada, to room by room requirements that recognize the need to distribute ventilation air to occupied areas within a dwelling.

#### Canadian Standards

The primary standard addressing residential ventilation requirements in Canada is the CSA-F326 Standard "Residential Mechanical Ventilation Systems". CSA-F326 [19] recognizes the importance of the distribution of ventilation air and, therefore, expresses the required ventilation rate on a room by room basis. It also includes a minimum whole house air change rate of 0.3 ac/h. Each type of room has a minimum acceptable fresh air supply requirement, based on room use. The master bedroom and basement require 10 L/s and other habitable rooms require 5 L/s. In the case of rooms with high contaminant generation, such as kitchens and bathrooms, minimum intermittent rates are

50 L/s for kitchens and 25 L/s for bathrooms. The continuous exhaust rates are 30 L/s for kitchens and 10 L/s for bathrooms.

Room by room ventilation requirements are usually met through the use of a ventilation distribution system. This ventilation system must be designed to operate continuously. At one time, CSA-F326 [19] also recognized the need for a capability of higher peak rates during periods of high contaminant generation, but this has since been removed from the Standard. The National Building Code (NBC) Part 9 Committee is considering the adoption of part or all of the CSA-F326 requirements for 1995.

The Canadian R2000 Program minimum ventilation requirements are for a continuously operating ventilation system capacity of 5 L/s per occupied room and 10 L/s for the master bedroom and unfinished basements. The maximum continuous rate need not exceed 0.45 ac/h (a continuous supply of ventilation air stipulated that the "off" period of the system cannot be more than one hour in any two hour period). As in CSA-F326, there are exhaust capacities of 25 L/s required for each bathroom and 50 L/s for kitchens. If exhaust is provided continuously from these rooms, the rates can be reduced to 15 and 30 L/s respectively. The ventilation system must not cause either a negative or positive pressure across the envelope greater than 10 Pa. When operated in conjunction with other intermittent exhaust devices, the ventilation system cannot contribute to a pressure differential across the envelope greater than 20 Pa.

CSA Standard Z240 covering mobile homes was changed in 1984 to require a ventilation system capable of providing 0.5 ac/h per hour, as in the 1985 National Building Code.

#### American Standards

ASHRAE Standard 62-1989 "Ventilation for Acceptable Indoor Air Quality" is the principal North American standard addressing residential fresh air ventilation and is also widely used or referenced internationally.

Recommended ventilation rates shifted drastically in the 1970s as energy conservation concerns arose. Recommended ASHRAE 62-81 rates were reduced from 7.5 L/s to 2.5 L/s for this reason. This single action alone is now considered by

## 2. VENTILATION REQUIREMENTS

many as the major factor in the rash of air quality problems experienced in commercial buildings throughout the 1980s [46].

ASHRAE Standard 62-89 expresses minimum recommended ventilation rates for residential single family dwellings in a different manner than in the past. The rate for living areas is 0.35 ach. The total air change must not be less than 7.5 L/s per occupant. For the purpose of calculating this ventilation rate, it is assumed that there are two occupants for the first bedroom and one for each additional bedroom. It is recommended that the kitchen be provided with an intermittent exhaust capacity of 50 L/s, a continuous exhaust capacity of 25 L/s, and openable windows. Bathrooms should be provided with an intermittent exhaust of 25 L/s, a continuous exhaust of 10 L/s, or alternatively, openable window(s).

### CODES REGULATING VENTILATION

#### National Building Code

The 1990 National Building Code requires that every dwelling unit be provided with a mechanical ventilation system having a capacity to exhaust inside air or to introduce outside air at a rate not less than 0.3 ac/h based on the total interior volume of the dwelling, averaged over any 24 hour period. When this ventilation air is provided by exhausting air, if there is a combustion appliance susceptible to spillage or a fireplace in the house, a make-up air supply must be provided to prevent house depressurization from reaching a level that will cause combustion gas spillage. No pressure limitations are put on supply-only ventilation systems. The code itself does not address the issue of comfort or potential condensation problems that could arise from providing make-up air or fresh air through a supply-only system, though it is discussed in the commentary. Where it can be shown that the house has sufficient air leakage that exhaust-only system operation will not cause combustion appliances to spill combustion gasses, then the Code exempts the builder from the make-up air requirements. The Code does not prescribe a method of establishing whether a house has sufficient air leakage.

#### Provincial Building Codes

The 1990 Ontario Building Code, contains the same fresh air ventilation requirements for houses as the 1990 National Building Code.

The British Columbia Building Standards Branch adopted the ventilation provisions of the 1985 NBC, which created great confusion in the housing industry. As a result, the B.C. code was amended. The B.C. Code now requires 0.5 ac/h ventilation capacity for non-distributed ventilation systems and 0.3 ac/h for houses with ducted systems. An exhaust fan controlled by a humidistat must provide 0.25 ac/h of the required ventilation capacity. All interior doors must be undercut sufficiently to allow air circulation. Where natural draft chimneys are present, make-up air must be provided. A series of tables in the code present ventilation rates, supply and exhaust duct sizes and make-up air opening sizes as a function of house floor area.

The 1985 Alberta Building Code requires that every dwelling have a mechanical ventilation system capable of providing at least 0.5 ac/h during the heating season. This can be provided by exhaust fans located in the kitchen and bathrooms with a make-up air inlet located remote from the exhaust fans, or through a duct connecting the outside to the furnace return air system. The Code requires that make-up air be preheated before it enters the occupied space. This ventilation air need not be provided on a continuous basis and need only be capable of providing the required ventilation rate.

The City of Edmonton is requiring a balanced ventilation system - what is exhausted must be supplied. Some use of appliances that exhaust air is allowed without make-up air being supplied, however, if larger exhaust appliances, such as downdraft grille top range fans are installed, according to Howell-Mayhew [38], they must have their own make-up air supply or the central system must provide the necessary make-up air.

The 1985 Northern Measures, reported by Mayo Communications [60], was produced as a model for use in Canada's Northwest Territories. It requires that ventilation adequate to maintain air quality at acceptable levels for occupants be provided to rooms or spaces within dwellings, either by means of natural ventilation or by a mechanical ventilation system. If mechanical ventilation is used, it must be capable of running continuously and provide at least 1.0 ac/h. It must also be provided with a variable-speed control and on/off switch.

## 2. VENTILATION REQUIREMENTS

---

### American Building Codes

Habitat Design & Consulting [46] reported that the U.S. Uniform Building Code (UBC) requires a ventilation capacity, whether by natural (windows) or mechanical means, of 2 ac/h for dwelling spaces and 5 ac/h for bathrooms. Minimum operable window areas expected to meet ventilation requirements are provided by the Code, though mechanical means which meet the code requirements may be substituted.

Habitat Design & Consulting also found that the Bonneville Power Authority "Super Good Cents" program requirements are for 5 L/s ventilation capacity for each bedroom and other combined living spaces, controlled by a timer. For HRVs, the minimum required continuous ventilation is the rate calculated by the above method or 0.25 ac/h, whichever is greater. In addition, there is a requirement for an intermittent exhaust capacity of 50 L/s for kitchens and 25 L/s for bathrooms.

The Department of Housing and Urban Development (HUD) according to Mayo [77] has jurisdiction over mobile homes in the U.S. Beginning in February 1985, all manufactured home dealers had to offer "mechanical ventilation improvement devices", with a required 12.5 L/s outdoor air supply, as an option on all mobile homes sold, and all buyers had to be made aware of the availability of this option.

### European Codes

Habitat Design & Consulting [46] reported on European Code requirements, as well. The 1969 amendments to the French standards required ventilation rates, measured at the air outlets, as follows: 12.5 to 25 L/s for the kitchen of a dwelling with less than three rooms, 16.6 to 36 L/s for the kitchen of a dwelling with three rooms

or more. Bathrooms were required to have between 8.3 and 16.6 L/s of exhaust capacity, depending on their use as laundries and the presence of gas water heaters. Amendments to the Code in 1983 provide a more sophisticated method of calculating ventilation requirements based on dwelling size and room uses. The Code allows perhaps the widest range of ventilation levels specifically tailored to dwelling size and use of any code in the world. The French Code requires an intermittent exhaust capacity of 26 L/s for a bachelor suite and 52 L/s for a 3 bedroom house with a living-room, dining room, family room and two bathrooms.

The Swedish Code sets basic ventilation requirements at 0.35 L/s per m<sup>2</sup> of floor area for all occupied areas. Individual room requirements are for 15 L/s exhaust capacity for small kitchens, and 10 L/s for small bathrooms and laundries. Increased exhaust rates are required for rooms in each category that exceed a maximum size or occupancy. The Swedish Code also links radon levels with ventilation rates.

Mayo [77] reviewed ventilation requirements in other European countries. In the Netherlands, the minimum ventilation rate, as of 1985, in dwellings was 7 L/s per person. Ventilation rate requirements are also specified on a per room basis. Kitchens require 21 to 28 L/s, bathrooms 14 L/s, living rooms 21 to 42 L/s and bedrooms 1 L/s. This ventilation can be provided through the use of windows except for the bedroom. As of 1983, Norway had no ventilation requirements and Denmark allowed ventilation to be provided through operable windows. In Switzerland there is no national ventilation requirement, each canton or town can set its own requirements. As of 1985, Belgium, West Germany and the United Kingdom had no national ventilation requirements.



### 3. VENTILATION EQUIPMENT AND COMPONENTS

#### SUMMARY

Ventilation fans are the heart of a mechanical ventilation system. They come in a variety of types and performance levels, with varying energy efficiency and sound output. Make-up air devices are described which can be designed into a ventilation system to ensure dwelling pressure balance.

A variety of ventilation controls have been investigated from simple on-off switches, to dehumistat controls, to sophisticated pressure-activated diaphragms to sense and activate other components to control dwelling pressure. The performance or pressure-flow characteristics of the more mundane ventilation system components such as roof-caps, terminations, wall-caps, sheetmetal or flexible ducting are discussed at length.

Heat recovery ventilators or HRVs are becoming commonplace in homes which are more airtight and enable adequate ventilation levels for occupant health and comfort while recovering useful energy from the exhaust stream. As mechanical ventilation systems can cause spillage or backdraft problems in fuel-fired heating systems integrated heating and ventilation equipment is under development which will ensure occupant safety in homes with combustion appliances.

Voluntary ventilation Equipment Performance Standards with uniform test methods and rating procedures have been developed and code developments could make mandatory the certification of ventilation equipment within the next few years.



## VENTILATION FANS

Fans provide the motive force necessary to move ventilation, make-up or supply air against the air flow resistance of ductwork, elbows, inlets, outlets and heat exchangers, where applicable. There are basically three types of fans used in ventilation systems. One type is in-line fans. Another, propeller or axial fans, move air axially through the blades. The third is squirrel cage or centrifugal fans, where the air enters the eye of the wheel and is spun by the blade wheel in a housing, before leaving the wheel and blower housing tangentially.

Propeller fans are intended for lower static pressure application. When external static pressures are high, centrifugal fans are used.

### TYPICAL VENTILATION FAN CONSTRUCTION

Simple bathroom fans have a coated sheet steel or plastic housing, with a backdraft damper generally built-in [40], made of either sheet metal or simply a rubber flap. The so-called "builder" models use a propeller fan with either an aluminum or plastic impeller. Very simple designs use a paddle wheel with radial vanes mounted on a flat disc.

The best models of bathroom fans use a centrifugal wheel of either metal or plastic construction.

The motors used in these products are commonly the shaded pole type, designed to run at 1450 or 1080 RPM, and are either open or closed construction. The larger fans or better models use permanent split capacitor (PSC) motors which tend to be more efficient.

Kitchen range hoods of the "builder" variety have shallow, inefficient canopies and use propeller fans. More expensive models use twin or double-wheel centrifugal fans. Range hood fan motors, like the bathroom fan motors, can be either shaded pole or permanent split capacitor type.

Japanese bathroom fans [40] are almost universally equipped with centrifugal blower wheels. Where propeller fan blades are used they tend to be wider, terminating in a long pointed tail. These blade profiles are claimed to be both quiet and energy efficient. Japanese range hood

fans have deep canopies, use centrifugal fans, and have two or three operating speeds. The cheapest range hoods use mixed-flow fans, which are more efficient than propeller fans.

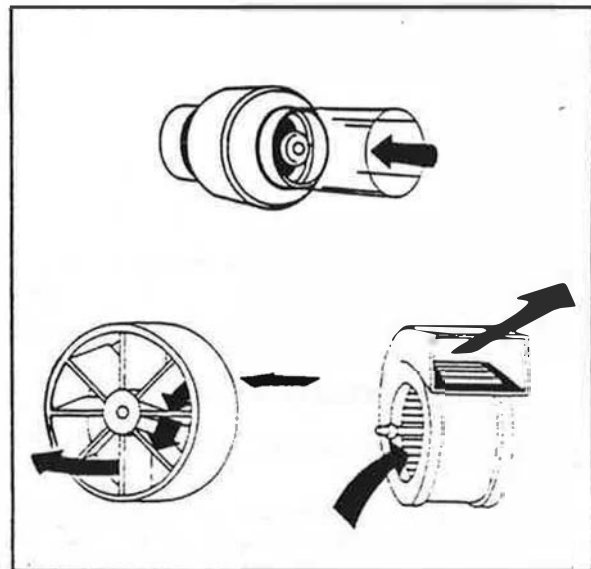

Fan Types : In-line fan (top), axial flow or propeller fan (bottom left), centrifugal or squirrel cage fan (bottom right)

### TYPICAL VENTILATION FAN PERFORMANCE

Ontario Research Foundation (ORF) [40] tested the airflow performance of 9 range hoods and 9 bathroom fans from different North American manufacturers. The nine range hood fans were found, on average, to deliver measured airflow within 90% of manufacturer's rating. The nine bathroom fans, however, averaged only 70% of manufacturer's rating. All tests were conducted in accordance with AMCA Standard 210-85 procedures with an external static pressure of 0.1 in H<sub>2</sub>O.

In a later study [54], ORF tested a Japanese bathroom fan against the same procedures. The motor was rated for either 50 or 60 Hz application at 100 volts. The manufacturer's claimed airflow rating was 24.5 litres per second at "free delivery" or zero external static pressure, at 60 Hz. ORF measured only 18 litres per second airflow at the same conditions. This represented only 73% of manufacturer's rated airflow and no better than the test results of the North American units.

### 3. VENTILATION EQUIPMENT AND COMPONENTS

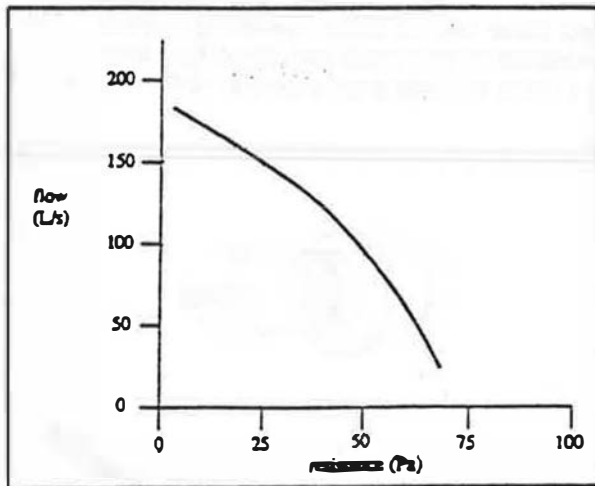

Fan Performance Curve

#### VENTILATION FAN / MOTOR SET EFFICIENCY

If a house requires 50 litres per second ventilation at a typical external pressure of 80 Pa, the amount of power in the flowing stream of air leaving the fan is only 4 watts. This is a small amount of power, which by itself, would seem reasonable given the importance of providing ventilation for both human and building needs.

ORF [40] measured the over-all fan/motor set energy efficiency of both bathroom fans and range hoods and found it to be between 2 and 4 percent. This means that between 100 and 200 watts of electrical power would be needed to impart the 4 watts of power to the ventilation air stream, in the example above.

This inefficient use of electricity makes it difficult for government regulators to insist on installation and continuous operation of balanced ventilation systems knowing that operating costs will be substantial.

In another investigation [24], the Institute for Research in Construction, on behalf of the Northwest Territories Housing Corporation, attempted to identify a low energy use, low noise

ventilation fan, for installation in Corporation housing. A letter was sent to 19 manufacturers specifying a fan/motor set with 2 speed capability, supplying about 40 litres per second, at high speed, and with a power consumption in the range of 25 watts. An operating life of 25,000 hours was also called for, with continuous duty on low speed.

Only one unit met the requirements. A price of \$130 was quoted based on an order quantity of 500 units. The rated power consumption was measured to be 26 to 28 watts. Assuming an external static pressure of 25 Pa, this represents an air power efficiency of only four percent.

#### VENTILATION FAN SOUND OUTPUT

There are several methods of expressing sound output from fans. The unit of measurement used by the Heating and Ventilating Institute (HVI) is the "sone". This scale of loudness has a linear scale. That is, a change in sone value is directly proportional to the loudness sensation. Better quality bathroom fans are rated at 1-3 sones, while range hoods have ratings between 4 and 6 sones.

The test procedure at HVI uses only one microphone position and one sample position and varies depending on the type of fan being tested. The procedure is said by HRAI and ORF [40] to be subject to significant changes in response, depending on source position or reflecting surfaces.

The Japanese use "Phons" which is a measure of loudness level of a particular sound equal to the Sound Pressure Level in decibels (dB), having an equally loud standard sound. There is apparently no reasonable basis for comparing sones and phons ratings.

According to the same work by HRAI and ORF [40], sound ratings presented in manufacturers catalogues should be used only as a guide and comparison of sound ratings should be restricted to only those rated by a similar unit of measurement, such as sone or phon.



#### MAKE-UP AIR DEVICES

Studies have shown that to prevent spillage or backdrafting of naturally aspirating combustion appliances, a maximum house depressurization of 5 Pa provides an acceptable limit. However, the flow capacity required in a house to ensure that depressurization does not exceed 5 Pa varies significantly depending on the capacity of the exhaust devices or appliances and the tightness of the house envelope. BLP [13] determined that a make-up air system of 125 litres per second would be suitable for a majority of Canadian houses. Here research efforts on make-up air devices which can be the components of a make-up air system are described.

#### ASSESSMENT OF MAKE-UP AIR DEVICES

On behalf of CMHC, BLP [13] evaluated a host of make-up air devices and systems. At the time, there were no integrated make-up air systems available, but they assessed the available components capable of one or more of the following functions, required of a make-up air system:

- provide air passage through the envelope;
- provide a driving force;
- control air flows;
- activate a flow control device;
- heat incoming air.

The following sections will elaborate on components providing these functions.

#### AIR PASSAGE PRODUCTS

This is a hole to the outside for make-up entry which consists of ductwork or individual vents. The size of the hole for make-up air depends on the house size, tightness of the house envelope, the resistance to airflow and the available driving force.

There are two types of envelope penetration or air passage products: a single, large entry for make-up air or the distributed, multiple entry to any number of rooms in a house. In houses with significant exhaust capacity, Buchan, Lawton, Parent Ltd. [13] concluded that larger openings, than currently used, would be required unless mechanical driving force was used. The same

study concluded that "distributed" system types were not favoured because they could lead to discomfort for occupants and more importantly, they could be turned off at precisely the time when needed to avoid depressurization.

#### DRIVING FORCE PRODUCTS

In passive systems, the driving force is the indoor-outdoor pressure difference, which of course needs to be controlled for such systems to be effective [13]. Fans can be used, either a separate fan or the existing furnace fan. The latter allows one to take advantage of the approximately 20 Pa negative pressure available in the return plenum, albeit not without control problems associated with hard duct connection to the plenum from the outdoors.

BLP [13] were unable to identify any specialized make-up air fans commercially available. The "Ventilation Fans" fact sheet contains further information on available fans for ventilation systems.

#### FLOW CONTROL PRODUCTS

A make-up air system could benefit from a flow control element, such as a simple manual damper. A variety of other dampers are available on the market, as well, such as: thermal type, barometric, or motorized. A fan can also perform the function of a flow control element if it is combined with an appropriate activation device. Some flow control devices use a bladder to restrict flow rather than a damper.

Manual dampers have the disadvantage of relying on user activation. Thermally activated dampers are normally mounted on the supply plenum of a warm air furnace and use the flow of heated air through a bypass duct to the return plenum, to open a damper to increase make-up air flow into the system. Barometrically operated dampers have a counter-balanced damper which opens or closes in response to pressure differences across the damper. The initiation pressure can usually be adjusted on such devices. Electrically-motorized dampers are often used for supplying make-up air. There are a number of suppliers of motorized in-line or duct dampers. Some have an adjustment so as not to be completely closed-off in the off position. Motorized dampers can be programmed to open when needed, can save energy and are unlikely to be tampered with or defeated by occupants.

### 3. VENTILATION EQUIPMENT AND COMPONENTS

The expandable bladder flow controller, available from one supplier, is capable of providing a relatively fixed flow over a broad pressure range. The performance aspects of the flow controllers are described in more detail in the "Ventilation Controls" factsheet.

#### ACTIVATION DEVICES

Where an electric damper or fan is used as a flow control device an external signal is needed to control operation. The furnace control can be used in the case of a furnace fan or flow control damper, for this purpose. The switch on an exhaust appliance can also be used as an activating or triggering device, signalling a requirement for make-up air.

Other than relays or switches from another appliance, such as a furnace or exhaust fan, no independent activation controls or sensors specifically designed for, or applicable to, make-up air were identified by BLP [13].

#### HEATING OR TEMPERING PRODUCTS

It may be necessary to separately heat make-up air in some systems. The extent to which this is necessary is dependent on the weather, the make-up air flow rate and the level of mixing prior to introduction to the occupied space. An air-to-air heat exchanger, for example, can be considered as a passive make-up air heater. Electric duct heaters are available from a variety of sources. One company [13] offers a 2 kW capacity heater, sufficient for modest make-up air flows, with an integral thermostat which can be manually set.

#### PRESSURE - ACTIVATED MAKE-UP AIR CONTROLS

Two companies have developed prototype pressure-activated make-up air controls on behalf of Canada Mortgage and Housing Corporation.

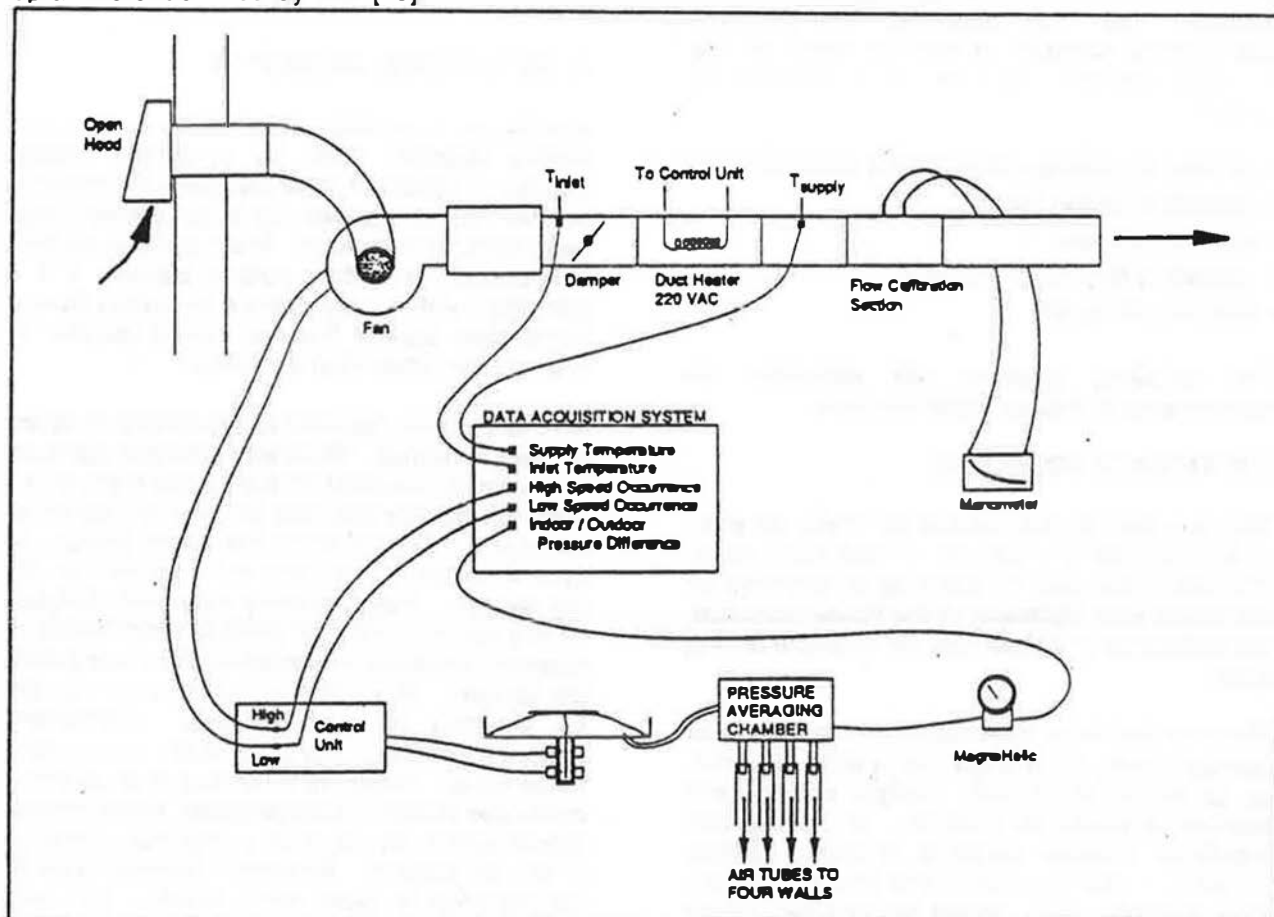

Lightweight Slack Diaphragm Pressure Control Under Test [13]

### 3. VENTILATION EQUIPMENT AND COMPONENTS

---

The BLP device consisted of a lightweight slack diaphragm, open to indoor pressure on one side, outdoor pressure on the other. The outdoor pressure averaging chamber was connected to pressure taps, intended for connection on each of four exterior walls of a house.

Movement of the diaphragm, in response to pressure differences, was detected by a light emitting diode and photo-sensitive transistor. Opto-couplers, turned on and off by the movement of a brass strip suspended from the diaphragm, sent signals to control power relays which could activate fans and a duct heater. For more information on this interesting device see the "Ventilation Controls" factsheet.

The Checker Manufacturing Ltd. unit consisted of a similar differential pressure control set to operate when a set pressure of 5 Pa (depressurization) was exceeded. The pressure control turns on a fan in the unit. As with the BLP device, the fan will continue to operate until the

level of depressurization of 3 Pa is reached, at which time the make-up air unit turns off. The checker device is designed to operate in a basement and a basement thermostat will turn on a make-up air heater, if the air temperature falls below a set temperature.

The unit has a centrifugal blower, driven by a shaded pole motor with an airflow capability of 110 litres per second. The heater is a two element (2 kW per element) corrosion resistant spiral-shaped finned tube, type controlled by a remote wall thermostat.

It has a barometric-type damper, positioned on the make-up air units intake, set at a pressure well above the desired set point of the pressure switch, to prevent opening due to wind pressure. The damper opens fully when the fan is activated and closes tightly against a gasket to provide a good seal, when the fan is off. The activation pressure setting is field adjustable to ensure that the unit doesn't short cycle.

The first part of the document discusses the importance of maintaining accurate records of all transactions. It emphasizes that every entry should be supported by a valid receipt or invoice. This ensures transparency and allows for easy verification of the data.

In the second section, the author details the various methods used to collect and analyze the data. This includes both primary and secondary data collection techniques. The analysis focuses on identifying trends and patterns over time, which is crucial for making informed business decisions.

The third section provides a comprehensive overview of the results obtained from the study. It includes several key findings that have significant implications for the industry. These findings are supported by statistical data and visual representations, such as charts and graphs, to make the information more accessible.

Finally, the document concludes with a series of recommendations based on the research findings. These suggestions are aimed at improving operational efficiency and enhancing the overall performance of the organization. The author also acknowledges the limitations of the study and suggests areas for future research.

## VENTILATION CONTROLS

Ventilation controls are used to allow manual or automatic control of the supply and/or exhaust of air to or from the space. They provide for occupant ventilation, odour or contaminant control, or make-up air for house pressure balance. Ventilation controls extend from the simple on-off switch to control an exhaust fan to a microprocessor controlled device for sensing and controlling the pressure equilibrium within a house. Most controls used today are rudimentary, but new developments are on the horizon.

In the following sections results of a number of Canadian investigations in the area of ventilation controls are presented.

### RESIDENTIAL EXHAUST EQUIPMENT CONTROLS

In a recent state-of-the-art review of residential exhaust equipment conducted by HRAI and ORF for CMHC [42], the control most commonly used with bathroom fans and kitchen range hoods was found to be the simple on-off switch. Combination fan/light switches were also commonly employed. Optional controls included mechanical timers to delay the fan shut-off, and multi-speed or continuously variable speed switches for range hood fan control. Central exhaust systems often incorporated a dehumidistat for ventilation control.

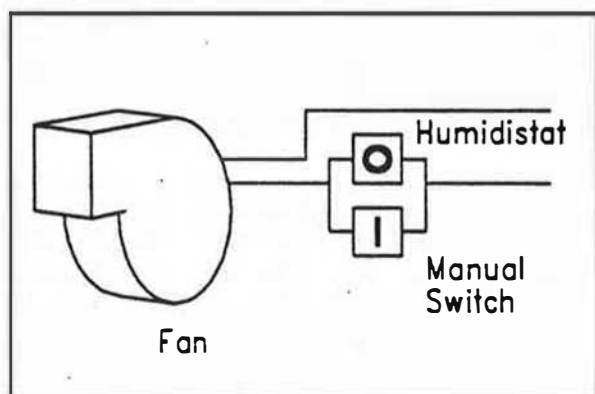

Combination On-Off Switch and Humidistat Fan Control

## HRV CONTROLS

A manual published by EMR [64] on the operation of Heat Recovery Ventilators included a section on the more common controls used with these units. Most HRVs have both a "low speed" and "high speed" mode of operation, with the latter used when extra ventilation is required.

The low speed is generally activated by the power switch located on the HRV and is often like the continuously variable speed switch available on some range hood fans. The installer normally sets the speed required for continuous ventilation and the setting remains unchanged.

High speed operation can be activated by the homeowner by switches located in the living area of the house. These manually activate high speed and in some cases can be automatically turned off after an interval of time. In some units interval timers are supplied which automatically switch an HRV to high speed for a fixed period of time on a regular basis.

Often an HRV is equipped with a dehumidistat to activate high speed operation when the humidity rises above a preset level.

### HUMIDISTAT CONTROL OF VENTILATION

Buchan, Lawton, Parent [11] investigated humidistat control of ventilation in a number of houses in Nova Scotia. Their objective was to determine whether humidity-controlled ventilation systems were appropriate for solving moisture problems in houses in Maritime climates. Of particular interest was whether there was a significant impact on the extent or severity of moisture related problems by controlling humidity in the homes.

The authors reported that the action of the humidity controlled fans did not make a difference to the average humidity level in the houses, but rather controlled the peaks.

While the fans were set to operate whenever the relative humidity exceeded 45 percent, the accuracy and drift of the simple humidity controllers, used to control fan operation, gave reason for concern. Drift of the controls could lead to excessive run-time.

Energy lost through the fans was insignificant at between 1 and 2 percent of the heating energy

### 3. VENTILATION EQUIPMENT AND COMPONENTS

consumed based on fan run-time, flow and indoor/outdoor temperature difference.

#### HUMIDITY CONTROLLED AIR INLETS

G.K. Yuill and Associates Ltd. [34] conducted a field evaluation of a novel ventilation system which incorporated humidity-controlled air inlets (HCAIs) produced by American Aldes Ventilation Corporation.

The HCAI is designed to be used with Aldes Ventilation Systems which normally use a central exhaust fan. The free opening of the Aldes HCAI varied, between 5 sq.cm. when closed, to 30 sq.cm. when open. In the test house, this resulted in a flow, when closed, which was 67 percent of the flow when the HCAI was fully open. These devices have an interior fixture which directs fresh air towards the ceiling. They also contain an integral filter and have two adjustable relative humidity operating ranges.

The HCAIs were installed in specially designed windows and were intended to direct the incoming ventilation air towards the ceiling - avoiding cold drafts in the room. The HCAI was apparently not deep enough to direct the air past the window frame and it was also concluded that the HCAI did not have sufficient turndown ratio or flow control variability for the house evaluated.

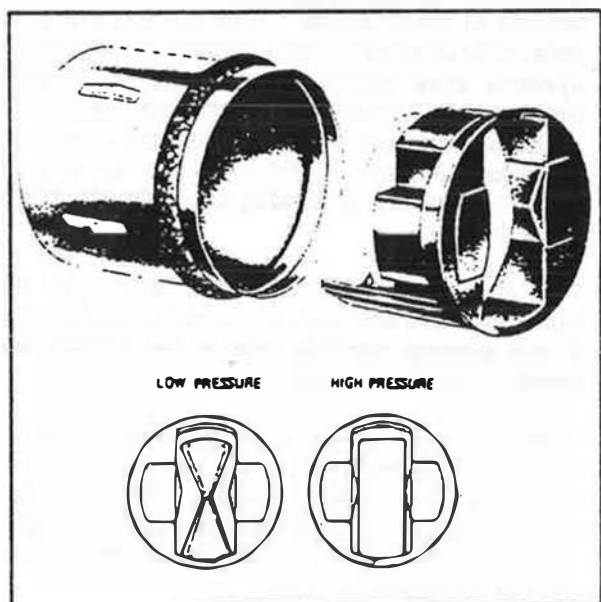

American Aldes Constant Airflow Regulator

#### HUMIDITY - CONTROLLED EXTRACTOR

A very similar product to the American Aldes humidity-controlled air inlet, is one offered by a French company called Aereco. Sheltair Scientific Ltd. [70] evaluated a humidity-actuated exhaust fan/extractor system manufactured by this firm.

There are apparently over 20,000 of these systems installed in Europe, where France for example, has required mechanical ventilation since 1982. The makers of this system claim lower installed costs and similar operating costs, to HRVs. Because ventilation is controlled, as a function of indoor relative humidity, the makers claimed that over-all ventilation rates can be reduced without any loss in indoor air quality.

The "extractor" units control exhaust rate, from the house, by varying its opening, in proportion to level of indoor relative humidity RH. The extractor opening contains an inflatable rubber tube with internal spring. The degree of opening is controlled pneumatically. As the RH rises the pneumatic circuit closes, causing the inflatable tube to lengthen, allowing greater exhaust flow. On a drop in RH, the tube shortens and inflates, blocking the opening causing the exhaust flow to reduce.

Measurements taken on a house equipped with the system indicated that the ventilation rate, while controlling relative humidity, did not satisfactorily control the CO<sub>2</sub> levels, particularly for the case of the high occupancy evaluated (7 occupants).

The extractor system did not respond to small humidity increases, response time was slow and the increase in ventilation rates was very slight. The investigators concluded that a fixed opening extractor would have been just as effective.

Humidity control as an exclusive control for ventilation rates may not be effective in controlling other pollutants, such as CO<sub>2</sub>. The occupants, however, were said to be pleased with the air quality and comfort of their home with the humidity-controlled extractor.

#### IMPROVED MAKE - UP AIR CONTROL

There are three types of make-up air supply control dampers on the market: thermally-activated, barometrically-operated and the electric-motorized type. The thermally-activated

### 3. VENTILATION EQUIPMENT AND COMPONENTS

utilizes a bimetallic coil, heated by air flowing through a bypass duct running from the furnace supply plenum to the return plenum. When the damper opens, on warming up, the negative pressure in the return plenum draws in outside air through the fresh air duct.

The barometrically-operated damper, opens and closes, depending on pressure difference across the damper. There is a counterbalance weight which can be adjusted to open the damper at different pressure differences.

The electric-motorized damper operates as an open/closed, two position damper and can be activated by either a 24 or 110 volt signal.

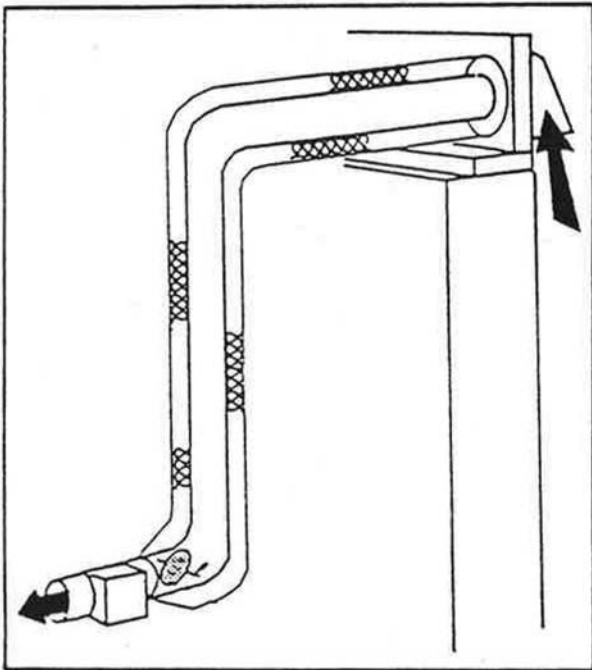

**Fresh-Air Inlet with Electric-Motorized Damper**

All three of these devices for one reason or another were considered deficient as make-up air controls. The thermally-activated damper suffered from thermal lag. It was also unable to compensate for other exhaust devices' effect on house pressure. The barometrically-operated

damper when connected to the furnace return was able to provide a degree of pressure control, but was considered unreliable and only capable of providing make-up air when the furnace fan operated.

The motorized damper, while an improvement over the thermally-activated damper in regard to lag time, still required furnace triggering to operate and still did not address the concern of operation of other exhaust devices, other than the furnace itself. Used in conjunction with a passive inlet air duct, with triggering by the operation of other exhaust devices, the motorized damper might offer the most effective solution of the current options available.

The prototype developed and tested by BLP [13] was a pressure-activated diaphragm, exposed to interior pressure on one side, exterior pressure on the other. When the house is subjected to relatively low negative pressure, air begins to flow into the space below the diaphragm, causing it to inflate. The displacement of the pressure-activated diaphragm is detected by a light emitting diode and photo-sensitive transistor.

This opto-coupler controls power relays which in turn activate a two-speed fan and duct heater. The diaphragm is initially pre-loaded and thereby the desired pressure setpoint is established. In the prototype, a two-speed fan and a duct heater were controlled. Output from the pressure-activated diaphragm opto-coupler could just as easily power dampers, turn-off exhaust appliances or any combination of such devices. The two-speed fan and 2 stage duct heater, ductwork and the pressure-activated diaphragm control were estimated to have an installed cost of about \$650.

Initial test results with the make-up air controller indicated that negative pressures went no lower than 5.3 Pa. Without the make-up air control, in the same houses, a negative pressure of 8.1 Pa was encountered. The investigators concluded that the pressure-activated diaphragm control was an effective means of controlling house pressure.





## VENTILATION SYSTEM COMPONENTS

There are a number of additional components beyond fans and controls needed in a ventilation system. These include wall, soffit or roof caps or terminations, sheet metal or flexible ducting, duct transitions and backdraft dampers. These components play an important role in determining overall ventilation system performance because they can account for a large percentage of the over-all ventilation system flow resistance.

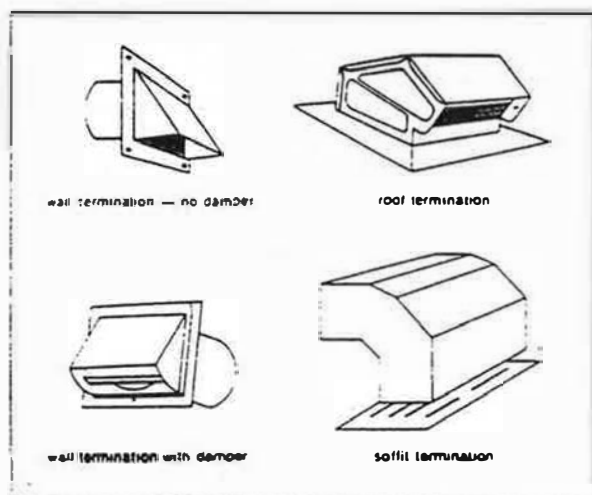

Different Types of Ventilation System Terminations [16]

### PRESSURE / FLOW CHARACTERISTICS OF COMPONENTS

The Ontario Research Foundation, ORF, [40],[54] undertook a state-of-the-art study and laboratory testing to obtain data on the pressure drop versus volume flow rate characteristics of ventilation system components. Much of the available data on these components had been evaluated many years before, and the components, in many cases, were no longer in use in ventilation systems. Modern components from various suppliers were obtained and airflow performance tests were undertaken in ORF's Airflow Test Nozzle Chamber.

The wall caps selected included: a bathroom exhaust system wall cap, with an integral spring loaded damper; a wall cap, with spring loaded damper, intended for connection to 85 mm by 255

mm rectangular duct; a plastic dryer vent wall cap commonly used in residential ventilation systems, but with a gravity operated damper.

The test results [54] showed the pressure drop across the wall cap to be remarkably similar in each of the three cases. Pressure drop was typically 15 to 20 Pa at a flow of 25 litres per second (typical of bathroom exhaust systems) and 30 to 40 Pa at a flow of 50 litres per second (typical of a range hood exhaust system). The bathroom system used 100 mm round duct, the range hood system 83 mm x 254 mm rectangular duct. The pressure drop generally increased with increasing flow rate. In the case of the wall cap with spring-loaded damper, intended for connection to rectangular duct, the pressure drop was relatively insensitive to increasing flow rate.

Roof caps were also tested in the ORF study [54]. One roof cap was intended for connection to 75 mm or 100 mm diameter duct with a gravity loaded damper, while the other was intended for connection to 85 mm x 255 mm rectangular duct and had both a spring and gravity loaded damper. Pressure drop at a flow rate of 25 litres per second was about 15 Pa in both cases.

### PRESSURE / FLOW CHARACTERISTICS OF SYSTEMS

ORF [54] tested system combinations, where the wall and roof caps were integrated into a system and the over-all resistance to airflow was determined.

One range hood system was constructed of components as recommended and supplied by the fan manufacturer, and all duct joints were taped. The other system used the same range hood but the wall cap was the commonly used dryer vent type, the ducting was 100 mm round instead of the 85 x 255 mm rectangular used above. Only the joints between the boot and range hood were taped, the duct joints were left untaped. Both systems were the same in over-all length.

In the first case, the pressure rise at the range hood fan was 50 Pa and the flow rate leaving the system was about 90 litres/sec. In the latter case, the pressure rise at the fan was 133 Pa, while the flow leaving the system was only 50 litres/sec. The use of 100 mm duct, rather than the recommended 85 x 255 mm duct, had reduced air flow by about 45 percent. Taping

### 3. VENTILATION EQUIPMENT AND COMPONENTS

---

duct joints apparently had a negligible effect on volume flow rate.

Similar tests of built-up bathroom exhaust systems were also undertaken: one system as recommended by the fan manufacturer, one system with the 100 mm dryer vent type wall cap and smaller 75 mm diameter duct. The other was identical to the previous except with a smaller 75 mm dryer vent wall cap. The last system had flexible duct rather than rigid, with other components as in the previous system.

The flow rate leaving the wall caps was highest for the system as recommended by the manufacturer. Dropping to the smaller 75 mm duct resulted in a 25 percent reduction in flow rate. The system with both smaller duct and wall cap had a flow rate about 30 percent lower than that of the recommended system. Finally, the most dramatic reduction was observed in the system using flexible duct. A 45 percent reduction in volume

flow rate leaving the wall cap was observed compared to that for the recommended system.

#### SYSTEM CONSIDERATIONS

ORF [42] concluded that it was important that the correct capacity fan was installed and that the ductwork was in accordance with the fan manufacturer's instructions.

Flexible duct should only be used where runs are short and only where a one size larger diameter duct is used. For example, 125 mm flexible duct should be used where 100 mm galvanized round duct would normally be called for.

ORF [42] concluded that systems requiring a large number of elbows should have all joints in the duct system taped to reduce excessive leakage. Where the runs are relatively straight, taping of duct joints is not required for ventilation systems.

## HEAT RECOVERY VENTILATORS

### INTRODUCTION

As houses become more airtight, a mechanical ventilation system becomes a necessity to remove stale indoor air and replace with fresh outdoor air. It is generally considered that a house air change should occur approximately once every three hours. In simplest terms, this can be accomplished by independent exhaust and supply fans. However, such a system wastes a great deal of energy, representing as much as one-third of the heating energy required in a well-insulated, tightly constructed house.

Heat Recovery Ventilators (HRVs), as the name implies, provide ventilation while recovering heat energy from the stale indoor air exhausted from the house. In their basic form, heat recovery ventilators consist of a heat exchanger, circulation fans (one for exhaust, another for fresh supply air), filters to remove dirt from the air entering the unit, condensate drain, defrost sensors and controls to remove frost which forms on the heat exchanger in the exhaust stream and controls for regulating the fan speed or ventilation amount, as needed. Some HRVs use heat pump technology in addition to, or instead of, heat exchanger cores to accomplish heat recovery from ventilation air.

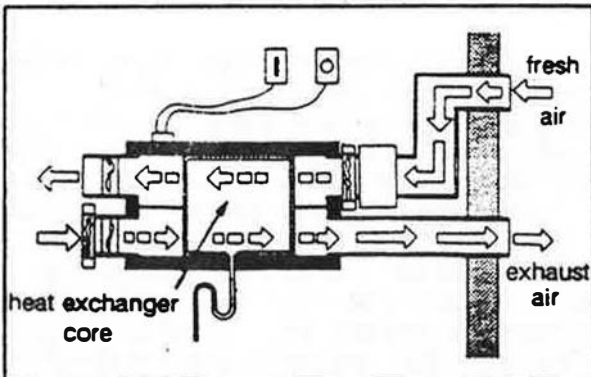

A Cross-Section of an HRV [64]

### COMPARING DIFFERENT HRVs

The R2000 Program in Canada is largely credited with encouraging and fostering the development of HRVs. A facility for HRV equipment testing and evaluation was established at ORF (now ORTECH) in 1983. Over the years, HRV manufacturers have significantly improved the

performance of their products through extensive development and certification testing required to comply with the requirements of the R2000 program.

HRV performance data prepared by ORTECH International are available for most HRVs on the market. The "HRVs Specification Sheet" provides information on the specific model tested, the airflow characteristics of the unit as a function of external static pressure, energy performance, fan power requirements, the heat exchanger effectiveness and a description of the defrost system operation.

### HRV FIELD PERFORMANCE

Numerous studies have assessed the field performance of HRV equipment. EMR [66] supported the measurement of airflow rates in 259 heat recovery ventilators installed in R2000 housing across Canada. In most homes, the systems were capable of providing more than the R2000 requirement (at that time) of 5 L/s per room and 10 L/s for basement and utility areas. In larger homes, however, the HRV flows were inadequate. Numerous problems were encountered including poor balancing, resulting in unbalanced supply and exhaust, which impacted on heating energy use, poor duct design, excessive use of flexible ducting and the use of small diameter duct which contributed to significant reductions in airflow. These results led to national training courses, an installer certification program and the introduction of "second generation" HRVs, with improved air flow capabilities, which promised to comply with program criteria and improved quality assurance.

### DIFFERENT HRVs EVALUATED

The Flair Homes Project in Winnipeg evaluated the performance of different types of ventilation systems [58] including conventional and heat pump-based HRVs. Both systems were examined. They were combined with the existing forced air heating distribution, or a dedicated air distribution system, in baseboard heated houses. The combined systems were able to achieve the design ventilation rates, with good mixing of ventilation air throughout the houses. Zone ventilation rates were not affected by interior door positions. While the dedicated HVR systems were able to achieve the design ventilation rates, the zone balancing was not as effective, as with the combined systems. Duct leakage was more of a

### 3. VENTILATION EQUIPMENT AND COMPONENTS

---

problem, as well in dedicated HRV systems, due to operation at higher static pressures.

The exhaust only heat pump-based HVRs were unable to achieve the design ventilation rates apparently due to significant unit casing leakage and internal cross-leakage. The other heat pump based HRV integrated the functions of space and domestic water heating into one package. This unit was also plagued with casing air leakage and large amounts of air escaped from the air stream through the condensate drain holes into the basement. Because large volumes of outdoor air passed through the heat pump, as the heat source, casing leakage had a dramatic impact on house airtightness.

#### HVR COMPONENT RELIABILITY

Howell-Mayhew [39] undertook a recent assessment of field installed HRV equipment in 10 homes in Alberta on behalf of Alberta Municipal Affairs. The survey consisted of, among other things, a check of system controls and HRV components. In two homes, the dehumidistat had not been installed; in another the damper motor was inoperative; in one house, the HRV heat exchanger cores were improperly installed; flow measuring stations required for field air flow balancing were not installed in one HRV and duct joints were only sealed in one of the ten homes.

Other HRV component problems encountered included defective defrost damper motors, defrost temperature sensors affected by condensation and corrosion, defrost dampers freezing to the intake port, filter shrinkage from washing resulting in poor fit in frame and casing insulation failure after considerable operation. The manufacturers have since addressed and corrected most of these problems. Although noise was said to be less of a problem than with earlier units, the requirement for a continuous supply of fresh air had resulted in complaints of noise associated with direct-drive furnace fan motors, in combined systems, in the survey. Direct-drive blowers were said not to be capable of lower speeds for reliability reasons. Thermostat controlled motors,

on the other hand, had high noise levels associated with the control itself.

#### HRVs AND MOULD GROWTH

Reports that other heating, ventilation and air conditioning systems were potential sources of airborne fungal contamination suggested that HRVs might also be subject to this problem. Whether fungi could be cultivated on any components of an HRV under optimum growth conditions was the subject of an EMR sponsored laboratory investigation [27]. A comparison survey of 74 HRV installations was also undertaken to sample and analyze the types of micro-organisms present under conditions of normal use. No mould growth was observed on any of the metal or plastic parts. Only paper or cardboard air filters were found to be susceptible to mould growth. The laboratory investigation concluded that there was little potential for mould growth in HRVs if they were properly maintained and filters replaced regularly. The field survey, meanwhile, found the same fungal species commonly found elsewhere in Canadian houses. The report concluded that HRVs are not a source of fungi in indoor air and did not pose a health hazard to house occupants. It stressed, however, the importance of proper installation and regular maintenance and cleaning to reduce the potential for mould growth in HRVs.

#### ORGANIC OUTGASSING FROM HRVs

In another laboratory study [55], concerns that plastic materials used in constructing HRV heat exchanger cores contributed to indoor air contamination, were investigated. After developing a procedure and apparatus for testing the cores, the test results showed no significant outgassing of organic compounds from the cores. If HRV cores were outgassing, the amounts were extremely low, well below trace levels typically present in ambient air. Ontario Research Foundation [55] concluded that a large sample of other HRV units would have to be similarly tested to allow general conclusions to be made regarding the outgassing from HRVs.

## INTEGRATED HEATING AND VENTILATION EQUIPMENT

While there has been considerable effort to develop ventilation equipment such as the heat recovery ventilator, little attention has been paid to resolving the problems of spillage and backdrafting of combustion products. The latter can be exacerbated in houses with tighter envelopes when the chimney must compete with other exhaust appliances such as central vacuums, clothes dryers and indoor barbecues.

Canada Mortgage and Housing [72] challenged ventilation and heating equipment manufacturers to produce a product which met the intent of CSA-F326, by providing ventilation in line with the Standard's requirements and by keeping house pressures within the limits set in the Standard. In the context of this article, "integrated" heating and ventilation equipment refers to the principle whereby all heating and ventilation appliances in a house work in harmony to ensure occupant safety in homes with combustion appliances.

The study concluded that meeting the ventilation air requirements has not been a problem, however, difficulties have been experienced ensuring that house depressurization does not exceed 5 Pa in houses with naturally aspirating heating appliances. Passive make-up air ducts were judged unacceptable, in controlling house pressure, necessitating designs incorporating make-up air fans. Some of these designs will be described in the following.

### AIR MANAGEMENT SYSTEM

Siricon Ltd. developed such a system under contract to Canada Mortgage and Housing [9]. The "Air Management" system modulates the supply of fresh air in response to the operation of exhaust fans in the house. It consists of a mixing box with two openings, one for fresh air, the other for make-up air.

The make-up air opening has a spring-loaded vane which opens at a specific pressure. Within the mixing box is a rotating damper which is activated by a stepper-motor controlled by a microprocessor. The damper rotates, increasing or decreasing the suction pressure in the mixing box and thereby controlling the rate of ventilation or make-up air. This damper is also linked to the spring-loaded vane on the make-up air opening.

The "Air Management" system manages both the safety and control of heating and ventilation. Burner operation, in the companion boiler, fan speed, water-to-air circulator pump modulation and supply air temperature, to the house, as well as house pressure, are controlled by the system.

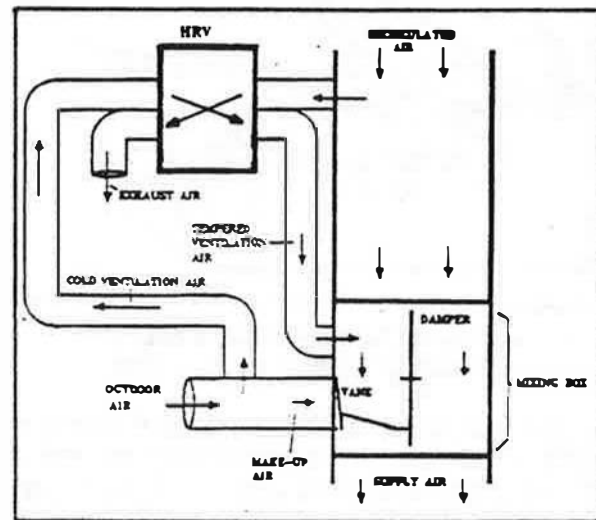

Air Management System Used with HRV [72]

Pressure control consists of a differential pressure sensor which outputs to the spring-loaded damper in the mixing box. Exhaust flow is reduced or fresh air intake increased by modulating the damper in the mixing box. When a critical negative pressure is experienced, the motorized rotating damper modulates the air intake damper to obstruct the return air flow from the house, while simultaneously opening the make-up air spring-loaded vane to bring in fresh air. The circulation fan can be speeded up to augment the make-up flow rate, as needed. The modulating damper can completely obstruct the return air flow to provide 100 percent fresh air in the supply air system, if needed.

### AIR MANAGEMENT MODULE

Sheltair Scientific Ltd. [49] developed a different approach to solving the problem of pressure control. Their "Air Management Module" (AMM) consisted of a rectangular box containing a centrifugal blower, a bank of copper tube heat exchanger coils perpendicular to the airflow, a piping loop from the boiler to the AMM, a circulator, a three-way mixing valve and a thermostat.

### 3. VENTILATION EQUIPMENT AND COMPONENTS

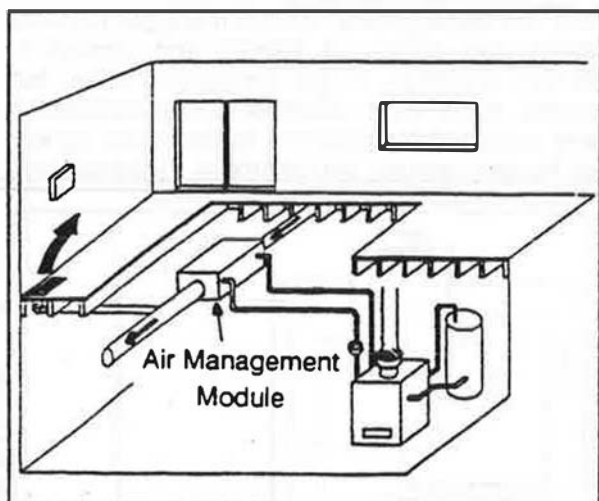

**The Air Management Module  
Pressure Control System [72]**

In the test home, a Central Exhaust Ventilator (CEV) was attic-mounted with ducts from each of the four bathrooms connected to it. Flow through the AMM balanced the exhaust flow through the CEV. The ventilation rate or speed could be selected by the occupant.

Pressure control, in this case, varied the flow rates through the CEV and AMM and other exhaust appliances. For example, if the CEV were at high speed, the AMM make-up air flow would match the resulting exhaust flow. If a powerful exhaust fan such as a clothes dryer or indoor barbecue were activated, the CEV would be switched to low speed, while the AMM would continue to operate at high speed. If needed, certain exhaust devices could be de-activated to prevent operation. The occupant could temporarily over-ride one of the devices affected, if inconvenienced.

The "Air Management Module" or the "Air Management System" are not presently commercially available.

#### INTEGRATED HRV

Another interesting integrated equipment development was undertaken by Venmar Ventilation Ltd. on behalf of Canada Mortgage and Housing [32]. Venmar's concept involved the integration of a heat recovery ventilator and a sophisticated pressure sensor/control system. The HRV was outfitted with motorized dampers in both the supply and exhaust ducts. Properly controlled, the dampers could regulate supply and exhaust flows to maintain house pressures within the limits specified by CSA-F326 "Residential Mechanical Ventilation Systems."

Venmar developed a simple pressure sensor consisting of a self-heating thermistor. Placed in a small pipe, with one side open to the outside, the other to the inside of the house, the air speed through the pipe could be measured and converted to the pressure difference, between the inside and outside. The range of the velocity sensor was from 0 to 6 metres/sec., with a stated accuracy of 0.1 metres/sec.

When there was a pressure imbalance in the house, the motorized dampers received a control signal from the pressure sensor, by way of a microprocessor. The dampers modified the flow rate in one or both streams, as needed, with the new flow measured and fed back to the microprocessor. The presence of other exhaust devices did not need to be known, merely their effect on the indoor-outdoor pressure as measured by the sensor.

The flow dampers were of the butterfly type, driven by DC motors through flexible driving shafts. A variable resistor was used to establish damper position. Butterfly dampers allowed for more linear air flow control, reducing the amount of hunting to find the correct operating position.

## EQUIPMENT PERFORMANCE STANDARDS

There is a need for credible equipment performance ratings to enable design professionals, builders and contractors to design and select ventilation equipment for residential housing in Canada. Performance standards and associated uniform test methods have been developed in Canada by the Canadian Standards Association to fulfil this need.

Performance standards are now in place for testing and rating ventilation products, to determine air flow capacity and sound output to an established uniform method.

### MANDATORY PERFORMANCE RATING OF EXHAUST FANS AND COMPONENTS

Canadian Standards Association Standard CSA-F326 entitled "Residential Mechanical Ventilation Systems" states that ratings for air delivery and sound output of supply and exhaust fans shall be determined in accordance with CAN/CSA-C260-M90 - "Rating the Performance of Residential Mechanical Ventilating Equipment".

While CSA-F326 is not yet referenced by either national or provincial building codes, it is anticipated that this will occur by 1995. When referenced by codes, manufacturer testing and

rating, of all ventilation equipment intended for residential housing in Canada, will be mandatory.

CSA-F326 also requires that heat recovery ventilators be tested and rated in accordance with CSA-C439 "Standard Methods of Test for Rating the Performance of Heat Recovery Ventilators". It also requires that ventilation system components such as air inlets, exhaust air outlets (wall and roof caps), filters and screens be accompanied by data on air pressure loss or flow rate characteristics. The standard does not specify how these ratings are to be determined.

### AIR FLOW STANDARD RATINGS

CAN/CSA-C260-M90 specifies that air flow be determined at 10 test points over the range from maximum static pressure (shut-off) to free flow (zero static). Both flow rate and pressure are to be measured at each test point, together with the electrical power and fan speed.

Flow rate measurements are performed in accordance with ANSI/AMCA/ASHRAE Standard requirements (ANSI/AMCA 210-85 and ANSI/ASHRAE 51-1985). These standards call for the use of a nozzle chamber where the volume flow rate is obtained by measuring the pressure drop across the nozzles, the static pressure at the nozzle inlets, the dry bulb temperature and wet bulb temperature, and then plugging these values into equations provided in the standard.

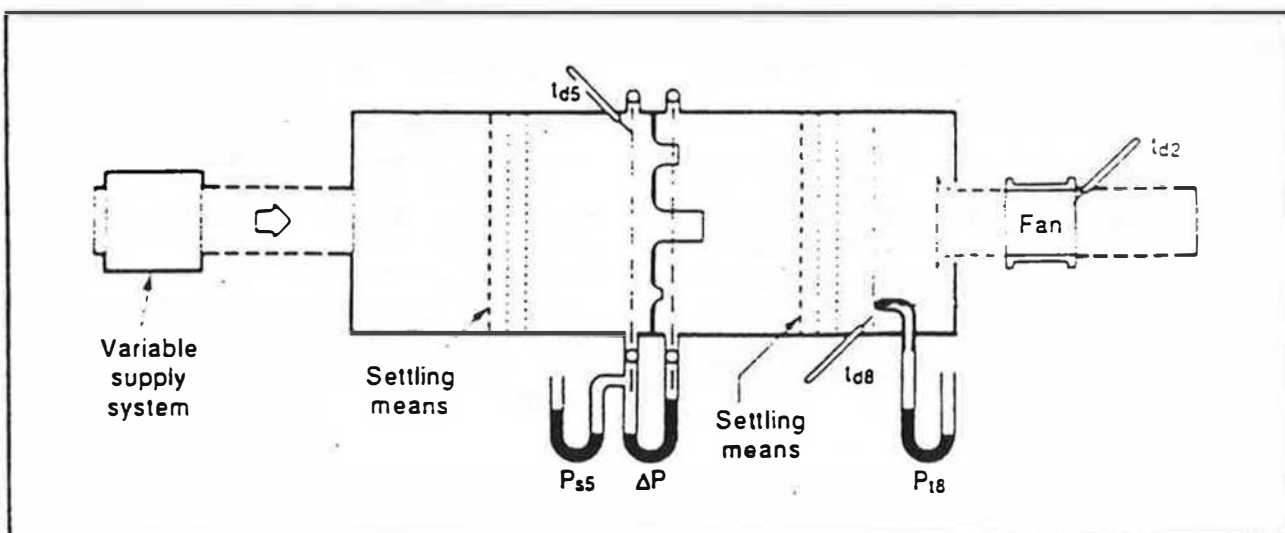

Multiple Nozzle Chamber for Airflow Measurement [ANSI/AMCA 210-85]

### 3. VENTILATION EQUIPMENT AND COMPONENTS

CSA-C260-M90 specifies the static pressure to be imposed on the fan under test depending on its classification (ducted inlet, ductless inlet, ducted outlet, ductless outlet). The standard provides diagrams of the nozzle chamber set-up for each of these situations.

The same standard describes cross-contamination tests for integrated supply and exhaust equipment. The supply and exhaust airflows are to be adjusted by the measured net leakage from the supply stream to the exhaust stream and the value obtained used for rating purposes.

Finally, CSA-C260 requires that fan manufacturers' air flow ratings be reported in available published literature as well as on a permanent marking on the equipment. The corresponding static pressure, at the specified air flow rating, is also to be shown on the marking.

#### SOUND POWER STANDARD RATINGS

CSA-C260-M90 also contains requirements for testing and rating ventilation equipment for sound power output. The test procedure used is claimed to produce a rating representative of the sound emitted by the ventilating equipment, when properly installed and operated in its intended application.

There are two steps in determining the sound power level rating. First, a reverberation room measurement is taken of the sound power levels emitted by a device in a sequence of one-third octave bands between 50 and 10,000 Hz. This is followed by an over-all sound power level measurement which is to be used as the product sound rating.

The device under test is installed in a manner which simulates field installed conditions. This varies with the classification of the device (non-ducted inlet and outlet, ducted indoor inlet or outlet, ducted outdoor inlet or outlet, ducted inlet and outlet). For each classification, figures are provided to show how to mount the device for the test. For example, various paths by which sound can enter a room are accounted for, such as

direct emission within a room, transmission through a duct bringing air to or from the room and vibration of walls or floor caused by the test device's own vibrations.

An anechoic chamber is required to ensure that reflected or reverberant sound from the space

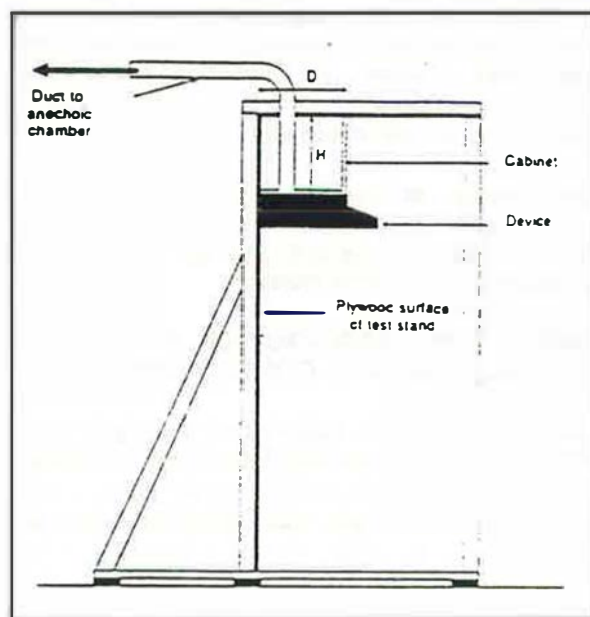

**Range Hood Installed for Sound Ratings [CSA-C260-M90]**

does not affect the sound power level measured in the reverberation room. Voltage and fan speed are recorded during the sound test to relate to the air delivery data. The fan speed must be within 1% of the speed recorded at rated static pressure during the air flow test.

The sound power measurements are to be made in accordance with ANSI Standard S1.31 at a minimum of three positions in the reverberation room. The sound rating shall be the A-weighted sound power level in decibels (dBA) calculated from the measured one-third octave band sound power levels measured as shown in the standard. An equivalent rating in sones can also be calculated by a procedure as specified in the standard.



## 4. VENTILATION SYSTEMS

### SUMMARY

The performance, relative merits and applicability of a large number of ventilation systems intended for houses is presented. The most common type of ventilation system is single point exhaust. Examples are bathroom fans and range hood fans. Systems with single or multiple exhaust pick-up points within a house and a central exhaust point, while not as common in Canada, have been investigated.

In order to avoid combustion spillage or backdrafting of fuel-fired appliances a balanced ventilation system is called for. A number of balanced systems, both heat recovery ventilator and simpler systems, are in use in Canada or have been field tested to determine their effectiveness. However, in many circumstances, supply-only ventilation systems such as the fresh air supply to return air plenum operate without exhaust fans.

An interesting ventilation system concept which has seen limited investigation is the dynamic wall. This approach uses negative pressure to uniformly draw in and pre-heat fresh outside air before entering the space. Passive ventilation systems, on the other hand, while simple, with both low initial and low operating cost are not always reliable. In northern or remote housing ventilation systems both passive and heat recovery ventilator concepts have been tried with some success.



### POINT EXHAUST

Point exhaust systems allow selective location of exhaust pick-up grilles and are relatively inexpensive. It is much more efficient to remove a contaminant at its source than to dilute the polluted air and exhaust the resulting mixture. Point exhaust systems use self-contained fan units to extract air from contaminant generating spaces in the house and exhaust it at that location as opposed to bringing the exhaust streams together and rejecting the combined flow centrally. Passive exhaust stacks, as discussed in the Passive Systems section, may also be considered to be point exhaust devices. Several other pieces of household equipment act as intermittent point-exhaust systems including: downdraft grille-top range fans, clothes dryers, fireplace chimneys and sometimes central vacuum systems.

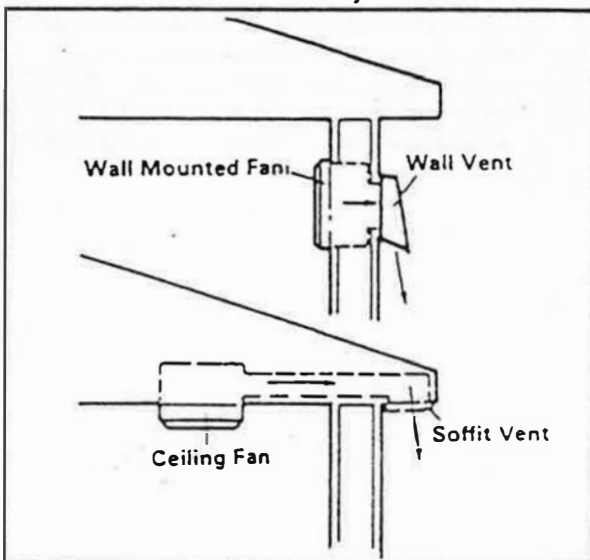

**Wall-Mounted and Ceiling Point Exhaust Systems [57]**

Point exhaust systems may be used in conjunction with virtually any type of fresh air supply system including Dynamic Walls, Fresh Air Supply to Return Air, or Passive Supply Systems.

Since point exhaust systems do not require elaborate duct systems to connect extraction points to a central fan, associated duct leaks and friction losses are eliminated. Also, there is normally no requirement to provide control wiring from a central point to each exhaust zone, as is often the case with central exhaust systems. The packaged nature of these devices makes them

relatively easy to use in retrofit situations where more complex systems can be prohibitively difficult.

The primary disadvantage of point exhaust systems is that it is generally not practical to recover heat from a number of distributed exhaust air streams. Wiring costs tend to be greater with these systems since a number of fans must be powered. Also, care must be taken with point exhaust or any other exhaust system used in a home with natural draft combustion appliances.

### VENTILATION SYSTEM PERFORMANCE

Caneta Research [21] investigated the performance of point exhaust systems with a variety of ventilation supply systems in two different houses. A continuously running exhaust fan in the kitchen and another in one bathroom provided the total required mechanical exhaust flow, as specified by CSA-F326. Simulation of a building generated pollutant (formaldehyde) and an occupant generated pollutant (carbon dioxide) showed that each system controlled contaminant concentrations to within ASHRAE and Health and Welfare Canada guidelines. These systems included:

- (a) fully distributed supply - no recirculation
- (b) partially distributed supply - no recirculation
- (c) basement only supply - no recirculation
- (d) supply to heating system return - low, moderate and high recirculation rates
- (e) supply to basement - moderate recirculation rate
- (f) kitchen and bathroom exhausts replaced with a single basement exhaust - moderate recirculation rate.

The results suggest that point exhaust systems may be effective with almost any ventilation supply system that ensures flow through all rooms. Upgraded kitchen range hood and bathroom exhaust fans must be employed to achieve the quiet operation and reliability necessary for continuous use. Mid-priced units were found to be capable of exhausting the required 76 L/s using the originally installed duct system.

### EXHAUST FAN PERFORMANCE

Bathroom exhaust fans and kitchen range hoods are the most common *point exhaust* systems in use, however they are seldom operated

#### 4. VENTILATION SYSTEMS

continuously. A survey performed by Sheltair Scientific [71] found that many of these units needed servicing and that poor installation practice was common. Bathroom and kitchen fans, that were actually moving air, had average flow rates of 17 L/s and 59 L/s. Duct leakage accounted for 35% and 22% (respectively) of the air exhausted at the grilles.

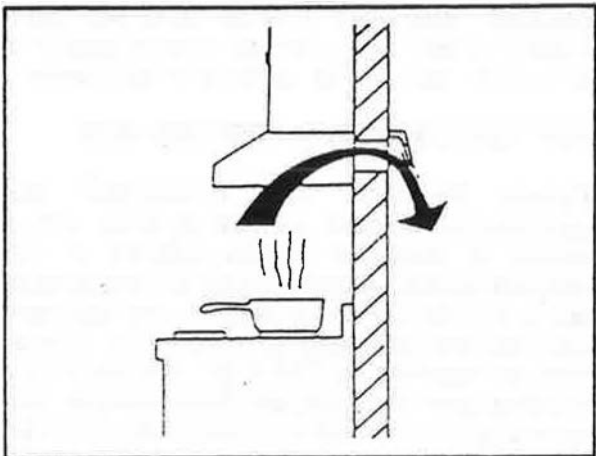

Range Hood Point Exhaust System [57]

An investigation by HRAI and ORF [41],[42] found that the exhaust airflows for bathroom exhaust fans and kitchen range hoods installed in Canadian homes were considerably below (typically less than 50% of rated flow) those published by the manufacturers. The study also indicated, that if systems were installed according to the manufacturers installation instructions, most residential exhaust systems would work as intended.

An analysis, by Hamlin et al. [35], of data gathered in earlier studies, examined the effectiveness of current ventilation system practice in meeting ventilation requirements in new housing. Assuming that all new houses have at least one bathroom and one kitchen exhaust fan, 64% could meet the air flow requirements of CSA-F326 (although typically the fans in use are inappropriate for continuous use). The average dryer, bathroom and kitchen fan would depressurize 20% of new houses by more than 10 Pa. When distribution, depressurization and air flow rates are accounted for, it was estimated that  $40 \pm 10\%$  of houses tested would meet CSA-F326 requirements with current ventilation system practice.

## CENTRAL EXHAUST

Central exhaust systems remove all of the mechanically exhausted air through a single duct, thereby maximizing the opportunity to recover heat from the air. Virtually all types of heat recovery ventilation systems utilize central exhaust. Generally, a single exhaust fan is used which minimizes wiring costs, limits installation effort, and lends itself to simple control as well. It also lends itself well to integration with pressure balance control systems that vary exhaust and/or supply flow rates in response to the indoor to outdoor pressure difference. It also makes it easier to use higher quality blowers since only one is needed. Limiting the number of building envelope penetrations, should also provide advantages in terms of cost and possibly airtightness.

A central exhaust system may have a single exhaust extraction point or it may use multiple pick-up points, connected by ducts, to take advantage of the efficiency gains associated with removal of contaminants at the source. Such systems may be used in conjunction with virtually any type of fresh air supply system or distributed inlet system. The primary disadvantage of central

exhaust systems, particularly in retrofit situations, is the expense associated with providing ducting to interconnect several exhaust pick-up points with the central system. Some additional expense may be incurred in providing capacity (speed) control at each of the exhaust extraction points.

## SINGLE POINT EXTRACTION

Caneta Research [21] tested and simulated an experimental central exhaust system which used essentially only one exhaust extraction point and an existing envelope penetration to expel air. The system consisted of a continuously operating draft-inducer fan connected to the house B-Vent and a manifold which allowed connection of the furnace and dhw heater exhaust vents and a house exhaust air duct, to the fan inlet. The system provided safe venting of combustion products and exhaust of stale house air with a minimum of over-ventilation during furnace or dhw heater firing. When simulated with a fresh air supply to the return air plenum this balanced single-exhaust-point system provided good air quality control, with only slightly higher contaminant concentrations than provided by a system using both kitchen and bathroom exhaust fans.

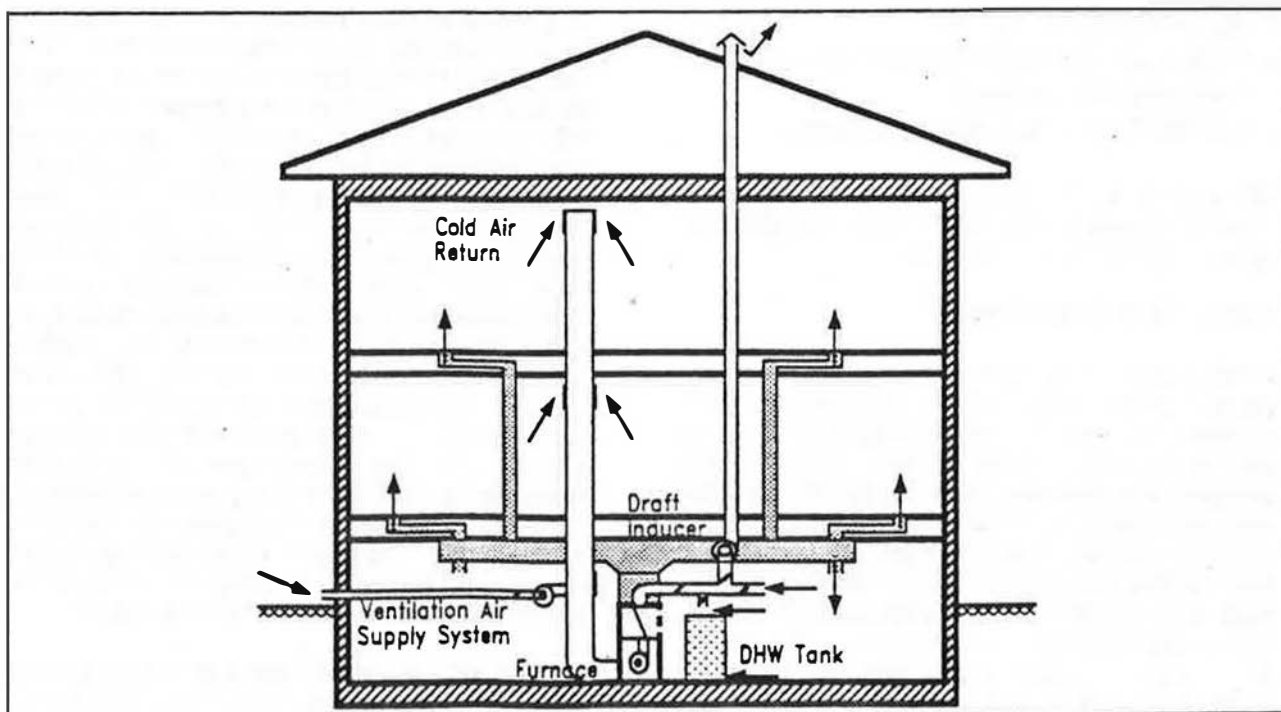

Experimental Central Exhaust System [21]

## 4. VENTILATION SYSTEMS

### MULTIPLE POINT EXTRACTION

In the same study [21], data analyzed from a balanced flow HRV system, with a single point supply and five point extraction, generally provided good indoor air quality but peak CO<sub>2</sub> levels were excessive, in an indirectly supplied and exhausted family room, even though the overall house ventilation rate was 0.3 ac/h.

Proskiw [59] performed measurements on a house with a two-point central exhaust system operated with and without recirculation.

While both systems met CSA-F326 dwelling unit continuous flow rate requirement, recirculation was needed to meet the room continuous flow requirements. Exhaust flow from the kitchen did not meet the continuous requirement of 30 L/s because an imbalance in flows favoured the bathroom. Duct leakage tended to reduce ventilation rates in above grade rooms and over-ventilate the basement. Interior door position did not have a significant impact on ventilation system performance.

Multiple exhaust pick-up points connected to a central exhaust system are common to a wide range of systems including:

- Heat Recovery Ventilators
- Exhaust air heat pump heat recovery systems
- Distributed inlet systems
- Humidity controlled extractor systems.

HRVs are examined in the next section, Balanced Ventilation Systems. Experience with the last three systems are summarized here.

### EXHAUST AIR HEAT PUMP

Proskiw et al. [58] installed and commissioned, pre-production exhaust-only heat pump heat recovery systems, in two Winnipeg houses, as part of the Flair Homes project. Each system used a four speed exhaust fan to provide variable ventilation capacity. House depressurization and resultant envelope leakage were used to supply fresh air that was well distributed. In winter mode, heat was extracted from the exhaust air stream and added to space and domestic hot water while in summer mode the system provided supplemental air conditioning.

One system was operated on the highest speed,

the other on the lowest. Even the higher speed system was unable to meet the design total ventilation rates, likely the result of significant case leakage and internal cross leakage. Design zone ventilation rates were also not achieved and both zone and total rates were affected by the position of interior doors. The manufacturer replaced the preproduction models with updated models after the testing was completed.

### DISTRIBUTED INLET SYSTEMS

Central exhaust, used in conjunction with distributed inlets, can provide an effective means of removing contaminants and providing fresh air where it is needed. One such system, the laminar air flow super window-humidity controlled air inlet-baseboard heating (LAFSW/HCAI/BH) system, was demonstrated and tested by G.K. Yuill and Associates Ltd. [34],[93].

The system is similar in concept to the Dynamic Wall, but provides some control of the fresh air supply and distribution and uses the windows rather than the opaque portion of the wall to introduce and preheat ventilation air. The exhaust fan depressurizes the space to allow the humidity controlled air inlets (HCAIs) to direct fresh air to the occupied spaces.

In practice, relative humidity was not found to be a good indicator of occupancy and the HCAIs were found to have insufficient effect on the fresh air flow rates. The negative pressure (4 Pa for all HCAIs open and 9 Pa for all HCAIs taped closed) was believed to be responsible for basement radon levels exceeding the U.S.E.P.A. action level of 4 pCi/L. While the overall air change rate of the house met the base requirement (CSA-F326) of 0.4 ac/h, some rooms received too little air. The formaldehyde level was measured to be 0.128 ppm, slightly above the Health and Welfare Canada long term exposure guideline of 0.1 ppm. While it was concluded that the HCAI system tested was not appropriate for the intended market, further development, including replacement of HCAIs with manually controlled air inlets, is expected to overcome the problems encountered. This type of controlled inlet system requires a very tight building envelope, if the intended flow distribution is to be achieved.

Another system uses humidity to control exhaust air flows rather than the supply flows. The Aereco humidity controlled ventilation system, with an exhaust capacity of 39 L/s, was installed and

#### 4. VENTILATION SYSTEMS

---

monitored by Sheltair Scientific [70], in a new energy-conserving house built in the Vancouver area. The fan was ducted to extractor units located in three bathrooms, the kitchen and the laundry room. Each extractor unit has a variable aperture which increases in size with increasing humidity, thereby biasing the local exhaust flow rate to be greatest in the most humid zone(s). Occupant control is present through the use of a manual override which temporarily increases the local extractor opening size.

The extractors did not respond to small humidity variations that occurred and while the occupants

did not complain about poor air quality, CO<sub>2</sub> levels regularly exceeded the ASHRAE guideline of 1000 ppm. Although not stated in the report, the system appears to be significantly undersized. (R2000 requirements call for a continuous capacity of 94 L/s.)

#### UTILIZATION

Proskiw [60] found that the utilization of three central exhaust systems averaged 0.62 h/day whereas the average use of 12 conventional HRVs was 19.3 h/day.





### BALANCED VENTILATION

Systems used to meet housing ventilation requirements may or may not be designed to supply the same quantity of air to the living space that they extract. When the ventilation system does provide equal incoming and outgoing air flows it is said to be *balanced*. When the system is considered to include the entire building, it must be balanced, since leakage will always make up for any discrepancy between the intentional intake and exhaust flows. Balanced ventilation systems *intentionally* provide equal fresh and exhaust air flow rates so that the indoor to outdoor pressure difference is not affected by the system, whereas unbalanced systems develop a pressure difference across the building envelope which drives the equalizing leakage air flow.

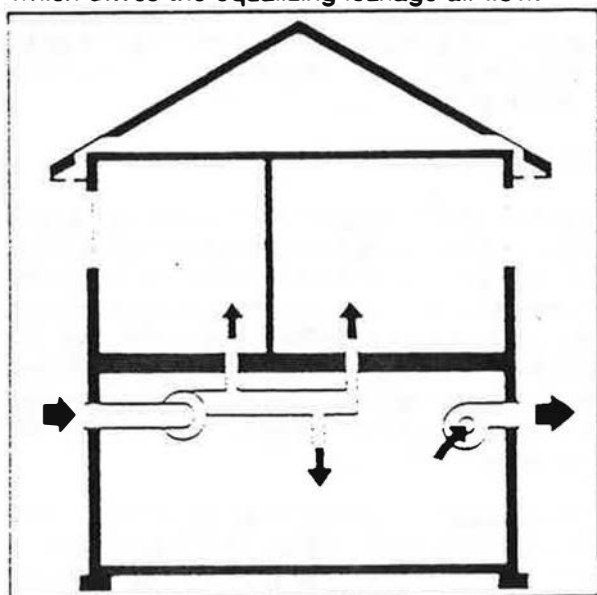

Balanced Ventilation System [57]

Balanced ventilation systems avoid numerous problems associated with unbalanced systems. Systems that are biased to the supply of air (supply-only systems for example) pressurize the building until leakage out through openings in the envelope equals the supply flow. Condensation resulting from the egress of humid indoor air through the envelope can cause serious moisture problems [85], and result in annoyances such as fogging between non-sealed window panes and freezing of door locks. Systems biased to exhausting air (exhaust-only systems for example), depressurize the building, causing outdoor air to infiltrate through openings in the

envelope. The low indoor pressure can cause natural draft combustion appliances, causing them to backdraft and spill combustion products into the space if sufficient make-up air is not provided. Depressurization can also increase the entry of soil gasses, including radon from small openings in the below-grade portions of the envelope.

### BALANCED SYSTEMS

Balanced ventilation systems may be categorized according to whether or not they recover heat from the exhaust air. Balanced systems without heat recovery can include, either central or distributed, fan driven supply and exhaust vents. Balanced systems with heat recovery are generally referred to as heat recovery ventilators. These systems which are described in greater detail in the Ventilation Equipment and Components chapter, typically utilize a heat exchanger to recover heat from the exhaust air and transfer it to the fresh air supply, however, in some units a heat pump is used for this purpose. Several manufacturers produce the former type while balanced heat pump heat recovery ventilators (HPRVs) are not common. Proskiw et al. [58] found that the commercial HRVs tested in the Flair Homes Project were able to achieve the design total ventilation rates when the system was designed, installed and commissioned in accordance with recommended practice, while the prototype HPRV appeared unable to achieve this, likely because of case and internal leakage.

Caneta Research [21] found that several low-cost balanced ventilation systems, with either central or distributed fans, were able to achieve design ventilation rates but a 3m long, 150mm diameter duct, connected directly to the cold air return plenum, was unable to supply the total design fresh air supply flow and therefore prevented the system from achieving balanced ventilation, as well.

### ACHIEVING AND MAINTAINING BALANCED VENTILATION

Balanced supply and exhaust flows are designed into these systems, by matching fan characteristics to the expected pressure drops, for both air streams, and by providing adjustable dampers to achieve a precise balance once the system is installed. Unfortunately there are a number of independent systems in houses which move air from inside to outside, or vice versa, on

#### 4. VENTILATION SYSTEMS

---

an intermittent basis, thereby disturbing the otherwise neutral pressure across the house envelope. Fuel burning furnaces and fireplaces, downdraft grille-top range fans, kitchen range hoods, dryers and central vacuums are all appliances that generally exhaust air independently of the central ventilation system. The operation of one or a combination of these devices can depressurize the house possibly causing the attendant problems which were noted previously.

Canada Mortgage and Housing has supported the development and testing of a device by BLP [13] that forces additional air into the house, as necessary to prevent depressurization from exceeding 5 Pa. Prototype testing suggests that the device meets all the fundamental requirements. The measured house pressure was relatively stable when no exhaust equipment was operating but there was a lag time of between one and two minutes before the make-up air equipment was able to increase pressure to a steady-state level. Under most of the test conditions (which included up to three exhaust appliances operating simultaneously) the system was able to limit depressurization to less than 5 Pa, however, the combination of fireplace and kitchen fan operation caused this limit to be exceeded. It should be possible to supply and install such a control unit in quantity for \$650. That system and others designed to actively maintain balanced ventilation are described in the Ventilation Equipment and Components chapter. While this study did not refer to the incorporation of such a device into the controls of an HRV, as a means of minimizing component and installation costs, Venmar [9] has investigated another approach.

A field assessment of heat recovery ventilators operating in Alberta [39] found that ventilation system balance could be seriously impaired by blockage of system screens and filters, frosting of the heat exchanger core and damper or other

mechanical failures. It was recommended that maintenance procedures be expanded to include inspection and cleaning of outside screens and that hinged intake screens be incorporated. It was further recommended that labelling and owner information need to be improved particularly with respect to servicing and maintenance. Defrost settings should also be changed at the factory for colder locations.

#### AIR QUALITY

In an investigation of the effect of mechanical ventilation systems on air quality in low leakage houses, Dumont [23] found that blocking the basement floor drains, in 10 homes that were found to have elevated radon levels ( $>4$  pCi/L), reduced the radon concentrations an average of 46%. This suggests that radon gas was being drawn into the space through the floor drains by an outdoor to indoor pressure difference, thereby demonstrating the importance of balanced ventilation.

#### ECONOMICS

Hawken [36] compared the cost of owning and operating two unbalanced systems, an exhaust fan and an exhaust air heat recovery heat pump (EAHRHP), and one balanced system, a heat recovery ventilator (HRV). He found that the EAHRHP was more attractive economically than the HRV except in locations where low-cost natural gas made both devices uncompetitive with the exhaust fan.

Subsequently, Linton [45] compared three balanced systems: supply and exhaust fans; a conventional HRV and an HPHRV. In this comparison, the HRV provided the shortest simple payback (between 1.5 and 5 years) in each of the three locations simulated. The HPHRV was next in economic attractiveness whenever electric heat, or relatively expensive gas (Montreal), was used.

#### 4. VENTILATION SYSTEMS

### SUPPLY-ONLY

Supply-Only Ventilation systems are those that provide fresh air to the living space but have no intentional provisions for removing exhaust air. Examples of supply-only systems include active

and passive fresh air supplies connected to the return air plenum, various central or distributed active vents, and passive vents that are installed below the neutral pressure plane. In each case, the supply system must operate without exhaust vents or fans if it is to be classified as supply-only.

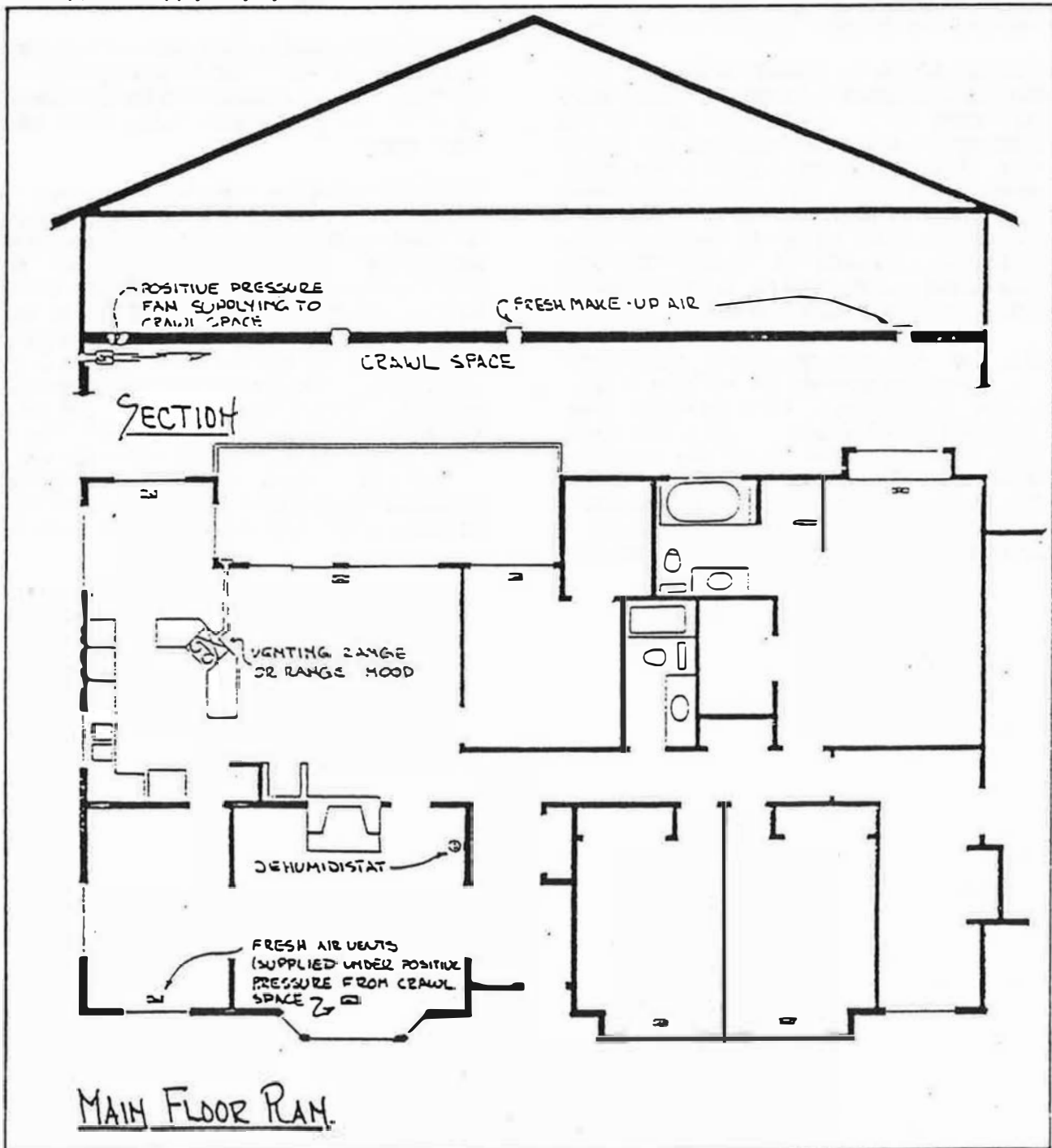

A Supply-only System Recently Installed and Tested on the West Coast [5]

#### 4. VENTILATION SYSTEMS

---

Such systems can be very simple, relatively inexpensive and do not create problems with the safe venting of natural draft combustion appliances, nor do they accentuate cold drafts from leaks in the building envelope. Supply-only systems will not cause contaminants such as radon, other soil gasses or envelope emissions such as formaldehyde to be drawn into the space.

However, supply-only systems tend to pressurize the space, increasing the amount of humid indoor air leaking out through the envelope and the likelihood of condensation and moisture damage there. Fogging between the panes of non-sealed windows and freezing of operable windows and door locks may also result. As with any means of providing fresh air, supply-only systems need to incorporate some form of preheating or tempering to allow the outdoor air to be introduced into the space without occupant discomfort.

A supply-only system was recently installed and tested in a Vancouver island home [5] (see figure on the previous page). In this installation a two speed fan was used to pressurize a crawl space under the living area and vents in the house floor allowed air that was preheated in the crawl space to flow up into the house. This system, which was designed to supply 0.15 ac/h continuously and 0.3 ac/h when a dehumidistat detected an

RH above 50%, cost \$450.00 to install. In the relatively leaky single-story structure where the system was installed, the resulting air quality was found to be reasonably good. The crawl space, which provides some tempering of the incoming air, must be dry if it is to be used as a plenum in a supply-only system.

A supply only system without recirculation, tested by Proskiw [59], met the CSA-F326 dwelling unit continuous flow rate requirement but was unable to meet the continuous room flow rate requirements.

While widespread use of the *Fresh Air Supply to Return Air* (which is covered in another section by itself) system makes *Supply-only* systems among the most common in use today, the potential for moisture-problems makes these systems unattractive relative to those of the balanced or negative pressure variety. Special situations, such as the need to prevent the entry of some soil or envelope contaminant, provide exceptions to this rule but have apparently provided little incentive for research into the topic. Since they are relatively simple and inexpensive, it would be useful to establish the range of conditions under which *Supply-only* systems may be used without causing damage to the envelope.

#### 4. VENTILATION SYSTEMS

### DYNAMIC WALL

The dynamic wall is an experimental concept in which the wall assembly acts as a ventilation air supply and preheat system while performing all the functions of a conventional wall. It is a subset of the negative pressure approach to ventilation in which air exhausted, by one or more fans, causes a pressure difference to be established across the envelope. This causes fresh, outside air to flow uniformly through the dynamic wall into the space.

Several advantages of this system are common to other negative pressure approaches: exfiltration related moisture damage to the building envelope is prevented, it is possible to recover heat from all

of the exhaust air and building construction costs are lower because a perfectly tight air-barrier is not required to ensure exfiltration control. The dynamic wall also offers the following additional benefits: simplified air distribution systems may be used since the fresh air supply is already distributed; preheating of supply air is automatically achieved in the uniformly distributed infiltration (avoiding cold drafts or the need for special supply air preheaters) and a greater fraction of available solar heat is captured. If a heat pump is used to recover heat from a central exhaust stream for domestic water heating, the air flow may be reversed in summer, providing "free" air conditioning. If the supply of hot water is dependent on correct ventilation system operation, maintenance of the ventilation system is more likely to occur.

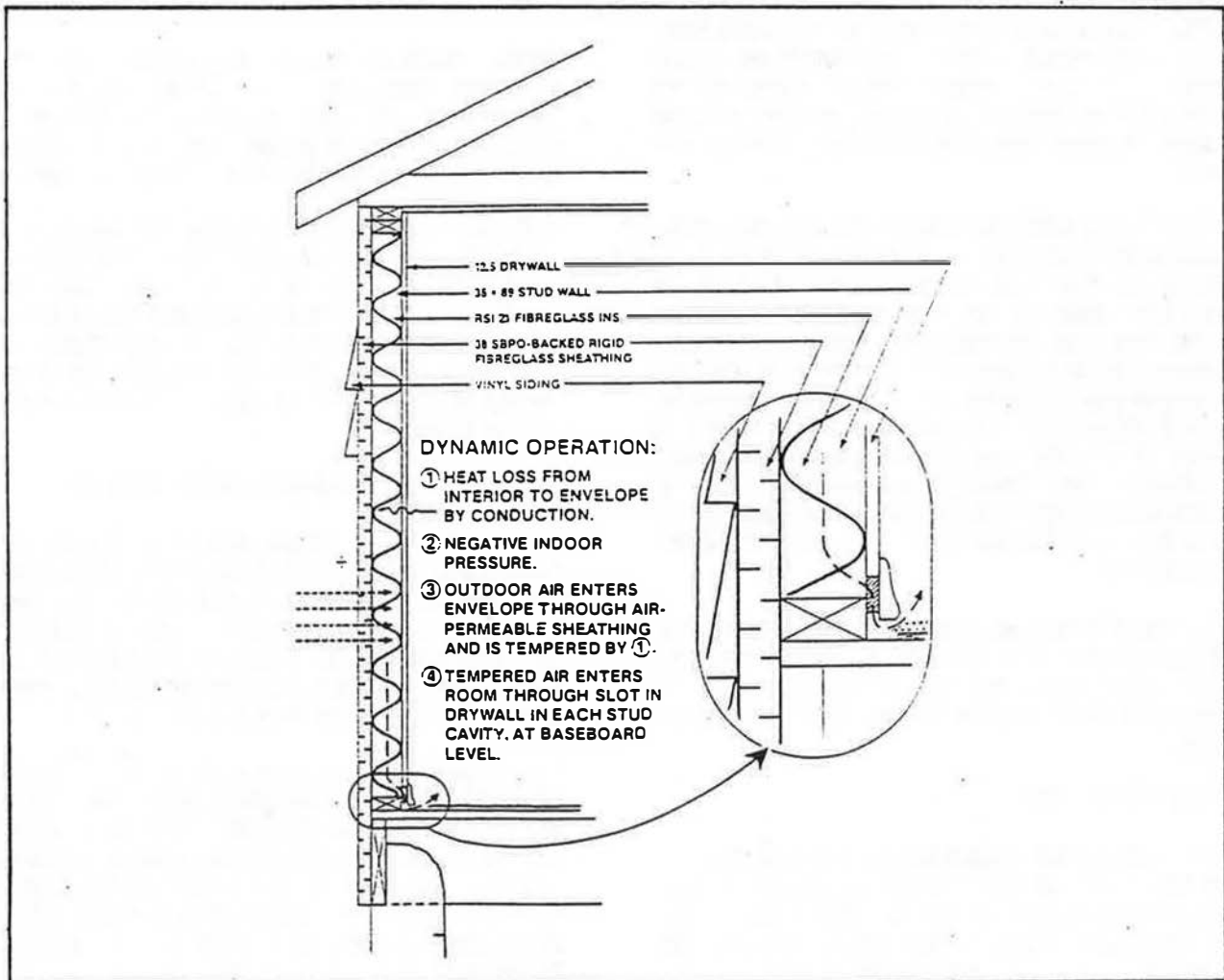

Dynamic Wall Operation [51]

#### 4. VENTILATION SYSTEMS

Limitations to the approach, which are similar for other negative pressure systems, include restrictions on the use of natural draft combustion appliances, and all of the ventilation air is drawn through a system of wall passages which are not accessible for inspection or cleaning.

With support from CMHC and the University of Toronto, Timusk et al. [78] built and, for several winter months, tested a dynamic wall house in central Ontario. The project was undertaken to demonstrate the concept and to monitor the performance of the house operating in a winter environment.

##### THE ONTARIO DYNAMIC WALL HOUSE

The University of Toronto Dynamic Wall House is a two storey (61 m<sup>2</sup> in plan) structure with an exposed wall area of 138 m<sup>2</sup>. The living area, which has a volume of 316.4 m<sup>3</sup>, is sealed from the crawl space below. The envelope cross-section, which is shown below, relies on an airtight floor and ceiling and a complete wrap of spun bonded polyolefin (SBPO) covering the walls.

Joints in the SBPO backing on the rigid fiberglass insulating sheathing were taped to provide an envelope that was relatively free of large air leakage sources, so that air would infiltrate uniformly over the wall area. Testing at various stages of construction indicated that the air tightness of the building was provided mainly by the SBPO and not the drywall or polyethylene. A total of seventy-nine 25mm holes were drilled through the drywall/polyethylene layer at baseboard height (54 on the second floor, 25 on the first) to allow dynamic air to uniformly enter the space.

To meet the ventilation requirements specified for R2000 homes and ASHRAE standard 62-81, 40 L/s (0.46 ac/h) continuous and 65 L/s, on demand, were provided by means of one exhaust fan.

##### TEST RESULTS

With wind speed varying between 10 and 30 km/h during most of the monitoring period, it was determined that incoming air temperatures were lowest on the windward side but that the variation was not large. The entire surface of the SBPO was determined to be infiltrating more or less uniformly. The house operated at an average

depressurization of 9 Pa at a 40 L/s ventilation rate and 13 Pa at 63 L/s. Air flows through the intentional holes in the drywall/polyethylene accounted for at least 50% of the ventilation air, at 40 L/s and 40% at 63 L/s. The total second floor flow was greater than that entering the first floor, suggesting that the 2:1 ratio of intentional openings in the drywall/polyethylene more than compensated for the reduced pressure difference (less by 2-2.5 Pa) there.

With the average outdoor temperature about 0 °C and the indoor temperature 20 °C, the mean incoming ventilation air temperature was about 17 °C when the ventilation rate was 40 L/s and 14 °C at 63 L/s. Solar radiation had a significant effect on the incoming air temperature. Thermography revealed no unusual cold spots on the walls even when the outdoor temperature was -20 °C and the higher ventilation rate being used.

Wood moisture levels suggested that the structural members were drying during the dynamic wall operation, however, it is not clear if the dynamic wall operation was responsible for greater drying rates than in conventional walls.

HOTCAN was used to estimate the net annual energy benefit of the system. While the reduced insulation effectiveness tends to increase the space heating requirement by about 6%, over the conventional case, the preheating of ventilation air is predicted to reduce the load by 18%, for a net saving of about 14%, or 1311 kWh, and a total load of 8,265 kWh.

##### THE ALBERTA DYNAMIC WALL HOUSE

Alberta Municipal Affairs funded a project by Nakatsui et al. [51] in which a dynamic wall house was built in a subdivision near Edmonton and monitored during the 1989-90 heating season. This work provided an independent evaluation of the cost, construction, operation and performance of a dynamic wall house in a cold climate.

The house is a two storey (110 m<sup>2</sup> in plan) structure with an above-grade envelope area of 426 m<sup>2</sup> and volume of 815m<sup>3</sup>. The incremental cost of the dynamic wall envelope and associated systems was estimated to be approximately \$4,200, relative to construction standards typical in the area, or \$900 more than a house built to R2000 standards using typical methods.

The dynamic wall concept house proved to be

#### 4. VENTILATION SYSTEMS

---

workable in the Alberta environment. The system was able to provide a total ventilation rate of 72 L/s or 0.33 ac/h (96% of the CSA-F326 continuous requirement for this house) with average pressure differentials of 4, 6 and 10 Pa measured across upstairs, main floor and basement walls respectively. It was estimated that the dynamic air flow rate was approximately 23 L/s under this condition. Changing wind speed and direction caused significant fluctuations in the pressure measured across the envelope. This resulted in corresponding changes in ventilation air flow distribution, but had little impact on the average degree of tempering that resulted. Solar radiation was found to significantly increase the dynamic air temperature. Operation of the dynamic wall reduced the interior wall surface temperature but occupant comfort was not adversely affected. Measurement of actual air exchange rates, radon, formaldehyde and glass fibre concentrations suggested that the indoor air quality was not compromised by the system.

Annual energy savings were estimated to be approximately \$250 for ventilation heat recovery (effectiveness of 50%) plus \$120 for avoided use of furnace and ventilation supply fans.

#### FURTHER WORK

While it has been demonstrated that the concept works, in as much as the system provided a continuous source of prewarmed air to all rooms without creating drafts or unacceptably cold wall surfaces, a number of questions remain about the dynamic wall. What is the effective increase in wall conductivity? How does dynamic insulation impact on indoor air quality (are there any significant emissions from materials in the wall cavity)? Are the predicted energy savings borne out in actual operation? Do the savings in preheating and distribution equipment offset the cost associated with the reduced insulation effectiveness? What design improvements can be made to the system?





## FRESH AIR SUPPLY TO RETURN AIR

An intake vent in the basement wall, connected by a duct to the return plenum of a forced-air heating system, is one of the simplest and most commonly used techniques for supplying fresh air to the living space. Sometimes this is the only intentional ventilation system installed, but frequently it is used with intermittent or continuously operating exhaust fans. Its capacity may be increased through the addition of a supply fan, and when used in conjunction with central exhaust a heat recovery ventilator may be installed (however direct connection to the return plenum is not recommended in this case, because ventilation balance will likely be altered by furnace fan operation).

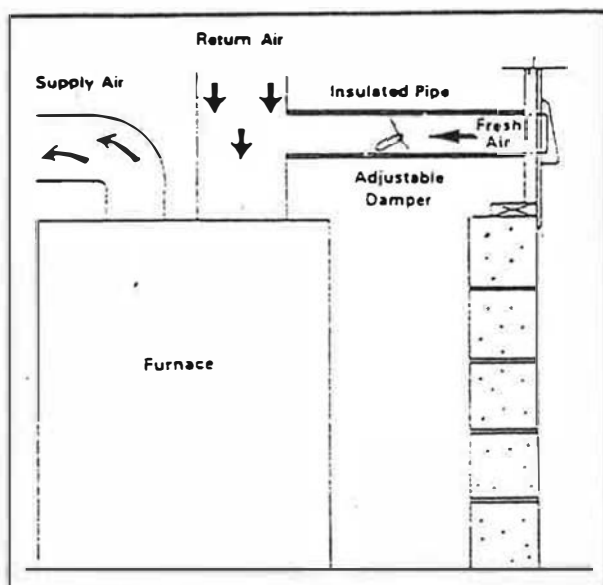

**Example of a Fresh Air Supply to Return Air Plenum System [57]**

In each of the above applications the use of the forced air distribution system is considered to be a relatively effective means of distributing fresh air and avoiding high local contaminant concentrations through mixing of the indoor air. This effectiveness combined with the simplicity and low cost of a fresh air vent are primary advantages. Its main drawbacks are a tendency to pressurize the house, a dependence on furnace fan operation (which is either intermittent and seasonally dependent or expensive to operate continuously), limited flow capacity, performance dependence on details of installation, and

potential problems with condensation causing premature failure of the furnace heat exchanger (as a result of exposure to cold outdoor air particularly during the off-cycle).

## VENTILATION RATES AND HOUSE PRESSURES

Shaw [69] found that, in a tight house, a 100 mm fresh air vent connected to the furnace cold air return, supplied 18 L/s when the furnace fan was operating. While this flow may be relied on whenever the furnace fan is operating, it is significantly less than the continuous fresh air requirement in most houses. He also determined that in the house he tested the neutral pressure plane was lowered by about 1.1 m (relative to the case where no supply vent was present), demonstrating the tendency for this system to pressurize the house and increase the likelihood of envelope moisture problems.

Caneta Research [21] measured flows between 40 and 50 L/s in a similar fresh-air duct, installed in a considerably looser house, that employed a 76 L/s continuous exhaust system. In the same house, a fan added to the fresh air duct easily provided balanced ventilation flows, but return-air temperatures as low as 7 °C were predicted at the furnace heat exchanger at outdoor air temperatures of -25 °C. In CSA-F326 the minimum allowable air temperature (ventilation air mixed with return air) entering the heating device is 12 °C. Some form of ventilation air preheat would be needed to meet this requirement. The same study also established that the ventilation supply fan did not require furnace fan operation to achieve effective fresh air distribution. In testing an exhaust-only ventilation system in another house, Proskiw [59] found that when the fresh air intake was connected at the low static end of the return air plenum, 71% of the ventilation air entered the house through envelope leakage and the remainder through the intake.

## AIR QUALITY

In a group of 46 houses, Dumont [23] measured high levels of formaldehyde (>0.1 ppm) in 50% of the houses without mechanical ventilation and in 27% of the houses with mechanical ventilation. Since he classified the simple fresh air duct connected to the return air plenum as a non-mechanical ventilation system, these results suggest that the subject system is significantly less effective than continuous mechanical

#### 4. VENTILATION SYSTEMS

---

ventilation systems in maintaining good indoor air quality.

##### **BUILDING CODE REQUIREMENTS**

*Fresh air supply to return air* is featured in two of three example ventilation systems, described in Appendix A of first revisions to the 1985 B.C. Building Code. In one example, the fresh air duct and a two speed furnace fan provide both the continuous (0.15 ac/h) and automatically controlled (0.3 ac/h), required ventilation supply air while exhaust is handled by the natural draft furnace flue. The other example uses a single speed furnace fan and adds a bathroom exhaust fan. The increased exhaust capacity requires a corresponding increase in the fresh air duct capacity.

##### **FURTHER WORK**

While 12 °C is used [19] as the lower safe limit for air passing over a furnace heat exchanger in the off-cycle, it is not clear that problems will occur if lower air temperatures are encountered, particularly when outdoor air temperatures are low and off-cycles tend to be short. If corrosion problems actually occur with these systems, simple, non electric-resistance preheaters might be developed.

Further investigation, to establish the minimum system requirements for good (effective and comfortable) air distribution with a fresh air fan (with the furnace fan not running) would contribute to good system design.

## 4. VENTILATION SYSTEMS

### PASSIVE VENTILATION

In Canadian housing, fresh air has traditionally been supplied by uncontrolled air flows through unintentional openings, driven primarily by pressure differences that are the natural result of wind and temperature difference between the living space and outdoors. While this is actually *passive ventilation* in its most basic form, only intentional passive ventilation systems will be considered here. Passive ventilation systems use intentional openings (that may or may not have some sort of damper control) to provide fresh air or remove exhaust air, without using fan power.

A fresh air duct connected to the return plenum of a forced-air distribution system, is considered by some authors to be a passive system since only passive components are added for ventilation. It is, however, treated by most as an active system since fan power is used to move the ventilation air. While the latter definition will be used here, systems that combine active and passive

components have been included in the discussion. *Fresh Air Supply to Return Air* has been treated independently.

Passive systems are attractive because of their simplicity, reliability, low operating cost and sometimes low first cost. Their primary limitation is that they are unable to provide adequate ventilation rates, when the indoor to outdoor temperature difference is small and the wind speed is low. Passive ventilation systems can however work well in conjunction with active (fan powered) ventilation systems and they can also improve ventilation in situations where they are used alone.

Shaw [69] conducted experiments on a number of passive and combination active/passive systems including: (i) an intake vent in the basement wall; (ii) an outdoor air supply ducted to the existing forced air heating system; (iii) an exhaust stack extending from the basement to the roof; (iv) a combination of (i) and (iii); and (v) a combination of (ii) and (iii). A reference case with

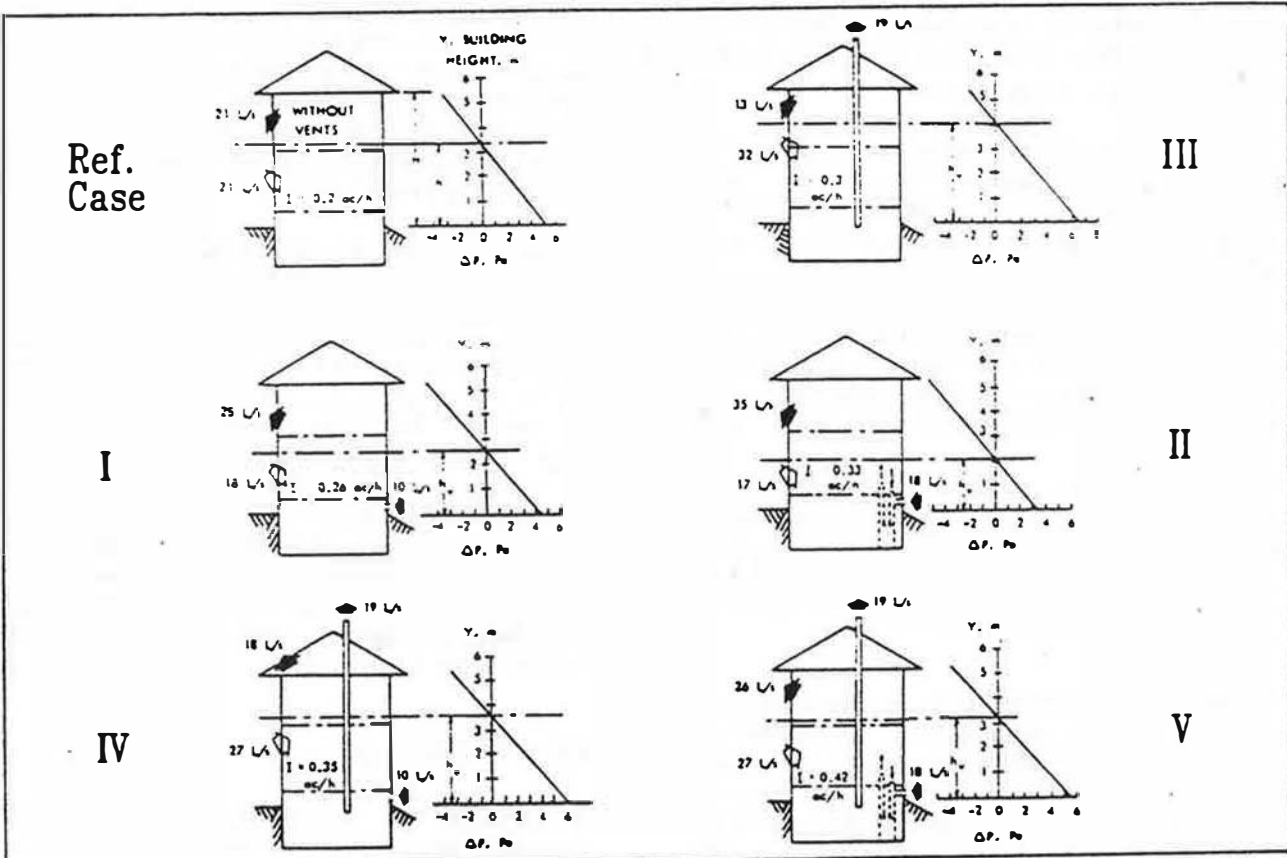

**Air Flow and Pressure Patterns for a Number of Passive and Combination Active/Passive Systems [69]**

#### 4. VENTILATION SYSTEMS

no intentional ventilation and some other cases, which included minor variations in the above systems, were also tested. Indoor and outdoor air temperatures, wind speed and direction, house air change rates and air flow rates through vent openings were measured in each case.

Analysis of the test results led to a number of useful findings. All of the ventilation systems increased the house air change rate relative to that of the house with no vents. With an indoor to outdoor  $\Delta t = 34$  K the measured air change rates for systems (i) to (v) were 0.26, 0.33, 0.3, 0.35 and 0.42 ac/h respectively, while the rate was 0.2 ac/h for the ventless house.

An intake vent in the basement wall, system (i), lowered the neutral pressure plane from 3.2 to 2.6 m above grade and at  $\Delta t = 34$  K, increased the air change rate by about 30% over the no-vent case.

Connection of the intake vent to the furnace return air duct, in system (ii), lowered the neutral pressure plane an additional 0.5 m and increased the air change by about 67% over the ventless case. The minimum air change rate (independent of  $\Delta t$  and wind) was 18 L/s or 0.17 ac/h for this active/passive configuration.

The use of a basement exhaust stack, system (iii), raised the neutral pressure plane to 4.2m above grade and at  $\Delta t = 34$  K, increased air exchange by about 50% over the no-vent case, to 32 L/s or 0.3 ac/h.

Combining the basement vent and exhaust stack, system (iv), resulted in the neutral pressure plane being 0.3m above the ventless case and the air exchange being 37 L/s or 0.35 ac/h, at  $\Delta t = 34$  K.

The active/passive combination of exhaust stack and intake vent connected to the cold air return, resulted in a neutral pressure plane that was 3.2m above grade, as it was in the no-vent case, but with an air exchange rate of 45 L/s or 0.42 ac/h at  $\Delta t = 34$  K.

The authors determined that the orientation and elevation of vent openings had little effect on house air change when wind speeds were less than 27 km/h. They also found that the location of an exhaust stack entrance has little effect on the house air change rate but it can significantly alter the effectiveness of contaminant removal.

#### PASSIVE SUPPLY

As discussed in the next section, Dumont [25] investigated a passive duct ventilation system, intended primarily for application in northern housing. This system, which employed vertical ducts running between the living space and the breezeway under the house, functioned as a ventilation supply system as distinct from the exhaust stack referred to above. It was found to provide additional air exchange but the increase was dependent on the outside temperature and wind speed and the supply of untempered air resulted in some occupant discomfort. It was suggested that the passive duct system could be improved with the addition of a low power exhaust fan and a fresh air preheater.

In a residential survey [71], Sheltair Scientific found passive fresh air ducts in only about 5% of housing stock with active ducts (those connected to the distribution system cold-air return) much more common. Due to the limited size of the passive duct sample, active ducts were included as well. In the combined sample, airflow at a pressure difference of 10 Pa was found to average 13.9 L/s. This compares to 18 L/s measured by Shaw in his testing of an active duct system, in a test house. "Heavy clogging with leaves and debris on passive and active fresh air duct inlet grilles" likely contributed to the difference in flows measured in the two studies.

Caneta Research [21] tested a system which used multiple passive inlets (one in each category A [19] room), in conjunction with an active exhaust system. Measured flow through the inlets was roughly an order of magnitude less than the exhaust flow rate and a pressure difference exceeding 5 Pa, 0.5m above grade, resulted. Under the test conditions encountered, second floor inlets supplied roughly one-third of the air provided by first floor inlets. It was concluded that under some normal operating conditions, the neutral pressure plane can fall to the level of the vents, causing the second floor inlets to stagnate. Therefore, the system does not constitute a reliable ventilation option.

#### PASSIVE EXHAUST

As stated above, passive exhaust stacks can effectively raise the neutral pressure plane and increase the overall ventilation rate in a house [69]. Van Poorten [85] investigated the use of

#### 4. VENTILATION SYSTEMS

---

passive exhaust vents as a possible solution to residential moisture problems in Newfoundland.

He found that stack performance could vary significantly with wind and that vent caps could enhance draft and prevent rain entry. For best performance stacks should be as high as possible and the use of an automatic damper, to limit peak air flow rates, was recommended. It was concluded that while the passive stack does exhaust air and raise the neutral pressure plane, it constitutes only a limited solution in Newfoundland because of the high ventilation rates necessary there. The author suggested that turbine ventilators were subject to freeze-up when

used to exhaust humid air from the living space.

Venmar [80] has developed a series of turbine ventilators that use wind energy to induce flow in exhaust ducts. The units are rated at 50 to 1040 L/s, at a wind speed of 3-5 m/s. The operating temperature range is from -40 °F to 120 °F.

#### AIR QUALITY WITH PASSIVE VENTILATION

Dumont's measurements [23] suggest that continuous mechanical ventilation is more effective than passive ventilation in controlling indoor air contaminant levels.



### NORTHERN OR REMOTE HOUSING VENTILATION

While the principles governing the ventilation of northern or remote housing are identical to those for conventional housing, several factors tend to make the application of ventilation technology more difficult.

Outdoor design temperatures of -40 to -50 °C and lower, place great demands on defrost and preheat subsystems. Since it is typically diesel generated, the use of electricity (up to 85 cents/kWh) to displace cheaper space heating energy (fuel oil) is often inappropriate from both cost and resource utilization points of view. Additional complications include the absence of basements, high moisture generation rates per unit of house volume and difficulty in obtaining the specialized maintenance capability required for ventilation system servicing at a reasonable cost.

Given the aforementioned constraints, it has been suggested [25] that appropriate techniques for the ventilation of northern housing may involve improvements to the relatively standard (for the north) passive duct system or re-designed heat recovery ventilators. The HRVs have substantially reduced power consumption and reliable low-temperature defrost capability.

### AIR QUALITY

Ferguson [31] performed detailed monitoring of carbon dioxide and relative humidity for CMHC in a newly constructed duplex, in Aklavik N.W.T., between March and July, 1989. The Northwest Territories Housing Corporation building employed four passive duct ventilators, and humidity controlled bathroom and kitchen exhaust fans in each unit, in keeping with recent practice of the corporation. The monitoring was undertaken to assess the real-time air quality, as indicated by CO<sub>2</sub> concentration, and to determine if relative humidity could be used to gauge air quality in modern Arctic Construction.

It was found that in moderately cold weather (-30 °C) the CO<sub>2</sub> level exceeded the 800 ppm objective for approximately 12 hours in a 24 hour day, while the average monthly concentration was less than 700 ppm. The author stated that there is no practical mathematical relationship between

normal levels of relative humidity and IAQ, as measured by the concentration of CO<sub>2</sub>. It was further concluded that the study was unable to prove whether or not continuous high levels of RH (>30%) are an indicator of IAQ problems.

### PASSIVE VENTILATION SYSTEMS

Talalayevsky [76] proposed a system of independent vertical ducts running from the breezeway under northern houses up through the walls to ceiling level supply air grilles in the living room and each bedroom, that would work in concert with kitchen and bathroom exhaust fans. The analysis presented suggested that supply and exhaust was accommodated by bi-directional flow in the ducts and predicted ventilation rates of approximately 1 ac/h when a 25 mph wind velocity was present at the duct terminations. It is also demonstrated that, at typical NWT energy costs, the cost of operating a 100 watt HRV is approximately twice the cost of meeting the total ventilation load with oil heat. Anderson [2] determined, through discussion with an occupant of a home where such a passive system was retrofitted, that "a real decrease in condensation problems" had occurred in the Fort McPherson home.

Dumont [25] performed careful analysis and testing on two housing units located in Aklavik, N.W.T. that employed the passive duct ventilation system developed by Talalayevsky. The duplex, originally built in 1985, was retrofitted with four passive ducts, per unit in 1987. Addition of the passive vents increased the leakage area of the units tested by about 16% and increased the air exchange by approximately the same percentage. Second floor vents provided relatively little flow compared to first floor vents of the same diameter. The use of more vents or greater pipe diameters to increase the ventilation rate should be approached cautiously as more vents would lower the neutral pressure plane and thus reduce the amount of flow per vent.

Advantages of the system include: no electricity needed; no maintenance required except for insect screen cleaning; ventilation air supplies may be located in each room; snow will not enter the house through the vertical ducts; and additional leakage area is added in a way that does not lead to moisture damage. Passive vents also have the following disadvantages: ventilation rate is not constant but instead depends on outside temperature and wind speed; main floor

#### 4. VENTILATION SYSTEMS

vents provide uncomfortably cold air; and second floor vents supply very little fresh air. It was suggested [25] that these problems could be overcome by continuously running a low power exhaust fan and preheating the air with a finned-coil heater supplied by the glycol-based hydronic heating system.

#### HEAT RECOVERY VENTILATORS IN THE NORTH

FSC [29] evaluated various HRVs in Iqaluit and Latham Island (Yellowknife), N.W.T. during the 1987/88 heating season and found that the relative humidity was controlled by the passive system with 0.25 ac/h. While the HRVs experienced performance degradation below 20 °C, suffered from snow packing of air intakes,

and were expensive to install, operate and maintain, they did operate more effectively than the passive system.

More recently, Ferguson [91] assessed the real-time performance of a second generation cold-climate HRV installed in a Dawson City, Yukon, duplex in the 1988/89 heating season. It was concluded that this unit performed much better than its predecessors in the Arctic environment. Freeze-up of the core occurred near -40 °C and this self-corrected when the outdoor ambient air temperature rose to about -30 °C. The unit is said to require minimal occupant attention and, in laboratory testing, was found to consume 114 - 121 watts at -40 °C with 60 and 54% sensible heat recovery (for 32 and 55 L/s net airflow respectively).

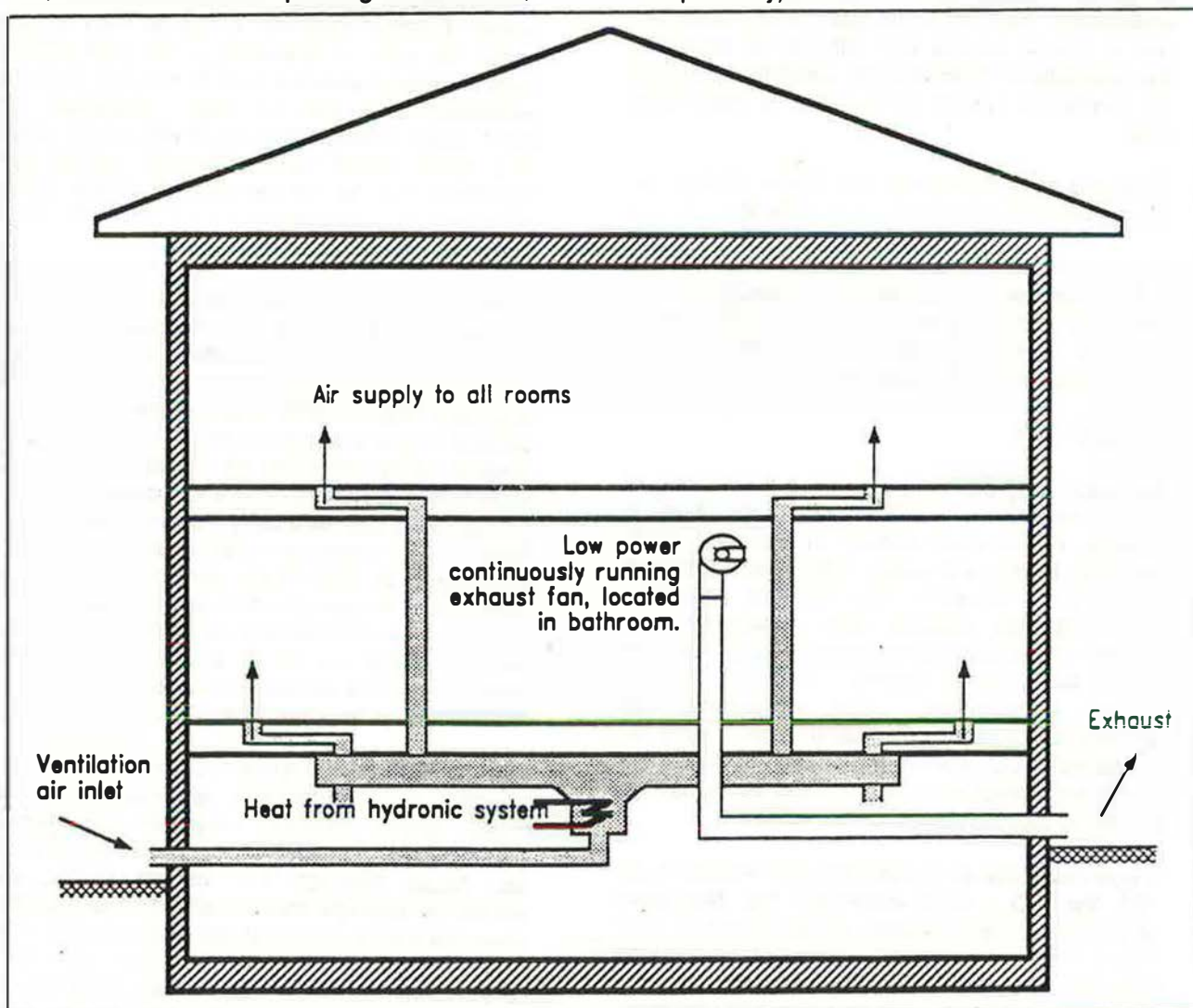

A Northern Housing Ventilation System With Hydronic Preheat of Fresh Air



## 5. REFERENCES



## 5. REFERENCES

- 1 Allen Associates. 1988, August. Residential ventilation industry cost survey. Canada Mortgage and Housing Corporation.
- 2 Anderson, R.; Northwest Territories Housing Corporation. 1987, December. Notes on Passive Air Ventilation.
- 3 Appin Associates. 1989, January. Non-electric automatic humidity activated flow control damper for passive systems. Canada Mortgage and Housing Corporation.
- 4 ASHRAE. 1989. ASHRAE Standard 62-1989, Ventilation for Acceptable Indoor Air Quality. American Society of Heating, Refrigerating and Air-Conditioning Engineers, Inc.
- 5 Avalon Mechanical Consultants Ltd. & Victoria Home Builders' Association. 1990, August. West Coast Ventilation Strategies, Phase 5 : Final Report. Canada Mortgage and Housing Corporation and British Columbia Hydro.
- 6 Balanced Energy Systems Technology, Inc. 1985, September. Field Evaluation of Residential Ventilation Systems Guideline: Final Report. Canada Mortgage and Housing Corporation.
- 7 Beach, R.K., National Research Council Canada. 1979, June. Relative Tightness of New Housing in the Ottawa Area. Building Research Note No. 149.
- 8 Besant, R.; Dumont, R.; Hamlin, T.; and Schoenau, G.; SOLPLAN 6 : An Air Exchanger for Energy Efficient Well Sealed Houses. The Drawing-Room Graphic Services Ltd.
- 9 Brais, A., Siricon. 1990. Development of an Integrated Heating and Ventilation System. Canada Mortgage and Housing Corporation.
- 10 Buchan, Lawton, Parent Ltd. 1986, February. Evaluation of the Potential for Fuel-Fired Appliance Backdraft in Ten Houses Equipped with Whole-House Exhaust Fans. Canada Mortgage and Housing Corporation.
- 11 Buchan, Lawton, Parent Ltd. 1986, May. Ventilation Alternatives for Maritime Houses. Canada Mortgage and Housing Corporation.
- 12 Buchan, Lawton, Parent Ltd. 1989, January. R-2000 Home Program Design and Installation Guidelines for Ventilation Systems. Energy, Mines and Resources Canada.
- 13 Buchan, Lawton, Parent Ltd. 1989, June. Improved Make-Up Air Supply Techniques. Canada Mortgage and Housing Corporation.
- 14 Canada Mortgage and Housing Corporation. 1986. Ventilation : Health and safety issues. Publication number NHA 5888 from the Builder's Series.
- 15 Canada Mortgage and Housing Corporation. 1987, November. Bibliography on Ventilation.
- 16 Canada Mortgage and Housing Corporation. 1988. Guide to Residential Exhaust Systems. Publication Number NHA 6114 from the Builder's Series.
- 17 Canadian Standards Association. 1984, September. CSA Standard C22.2 No. 113-M1984, Fans and Ventilators.
- 18 Canadian Standards Association. 1987, April. CSA Standard C22.2 No. 155-M1986, Electric Duct Heaters.
- 19 Canadian Standards Association. 1990, October. CSA Standard CAN/CSA-F326-M91, Residential Mechanical Ventilation Systems.
- 20 Canadian General Standards Board. 1986. CAN/CGSB-149.10-M86, Determination of the Airtightness of Building Envelopes by the Fan Depressurization Method.
- 21 Caneta Research Inc. 1990, September. The Effectiveness of Low-Cost Continuous Ventilation Systems. Canada Mortgage and Housing Corporation.
- 22 Dickens, H.B. 1985, December. Controlled Ventilation in Housing - A Summary review. Energy, Mines and Resources Canada and The Canadian Standards Association.
- 23 Dumont, R.S.; National Research Council. 1985, April. The Effect of Mechanical Ventilation on Rn, NO<sub>2</sub> and CH<sub>2</sub>O Concentrations in Low-Leakage Houses and a Simple Remedial Measure for Reducing Rn Concentration. IRC Paper No. 1383.

## 5. REFERENCES

- 24 Dumont, R.S.; National Research Council . 1988, June. Low Power Ventilation Systems for Northern and Remote Housing, Appendix 'G' : Energy Efficient, Low Noise Bathroom Exhaust Fans. Energy, Mines and Resources and Northwest Territories Housing Corporation.
- 25 Dumont, R.S.; National Research Council of Canada. 1989, January. An Innovative Ventilation System for Northern Housing. Energy, Mines and Resources and Northwest Territories Housing Corporation.
- 26 Energy Conservation Branch. 1986. Ventilating Your Home. Alberta Energy and Natural Resources.
- 27 Energy, Mines & Resources. Mold Growth in Heat Recovery Ventilators. from R-200 Publication: "The Air you Breathe".
- 28 Federal-Provincial Advisory Committee on Environmental and Occupational Health. 1987, April. Exposure Guidelines for Residential Indoor Air Quality. Minister of National Health and Welfare.
- 29 Ferguson, Simek, Clark Engineers and Architects. 1988, November. Northern Ventilation Project - Data Collection and Report for Iqaluit, N.W.T. Canada Mortgage and Housing Corporation.
- 30 Ferguson, Simek, Clark Engineers and Architects. 1990, August. An Analysis of the VanEE Arctic Two Heat Recovery Ventilator in an Arctic Installation - Data Collection and Report. Canada Mortgage and Housing Corporation.
- 31 Ferguson, Simek, Clark Engineers and Architects. 1990 September. A Review of Air Quality Data obtained for a High Arctic Duplex - Data Collection and Report. Canada Mortgage and Housing Corporation.
- 32 Forest, D., Venmar Ventilation Limited. 1989, October. Integrated System Project. Canada Mortgage and Housing Corporation.
- 33 G.K. Yuill and Associates Ltd. 1987, December. Investigation of the Indoor Air Quality, Airtightness and Air Infiltration Rates of a Statistically Random Sample of 78 Houses in Winnipeg. Canada Mortgage and Housing Corporation.
- 34 G.K. Yuill and Associates Ltd. 1989, November. Project to Continuously Monitor the Performance of the Laminar Air Flow Super Window - Humidity Controlled Air Inlet - Baseboard Heater Ventilation and Heating System. Canada Mortgage and Housing Corporation.
- 35 Hamlin, T.; Forman, J.; and Lubun, M. 1990, May. Ventilation and Airtightness in New Detached Canadian Housing. Canada Mortgage and Housing Corporation.
- 36 Hawken, P.J. 1984, September. A Comparison of Ventilation Strategies for tightly Constructed Houses in Cold Climates. National Research Council.
- 37 Hayson, J.C. and Reardon, J.T., National Research Council of Canada; Mansour, R., Canadian Home Builder's Association. 1990. 1989 Survey of airtightness of new, merchant builder houses. Proceedings of the Conference "Indoor Air Quality : IAQ 1990", Toronto, pp. 263-268.
- 38 Howell-Mayhew Engineering, Inc. & Sunton Engineering, Ltd. 1989, December. Demonstration, Monitoring and Evaluation of Practical Ventilation Systems for New Alberta Houses. Alberta Municipal Affairs.
- 39 Howell-Mayhew Engineering, Inc. 1990, July. Assessment of heat recovery ventilator operation and performance in Alberta. Alberta Municipal Affairs.
- 40 HRAI Technical Services Div.Inc. and Ontario Research Foundation, Energy Systems Centre. 1987, November. Residential Exhaust Fans : Literature and Equipment Search. Canada Mortgage and Housing Corporation.
- 41 HRAI Technical Services Div.Inc. 1988, August. Field Study and Field Testing of Residential Kitchen Range Hood and Bathroom Exhaust Systems. Canada Mortgage and Housing Corporation.
- 42 HRAI Technical Services Division Inc. and Ontario Research Foundation, Energy Systems Centre . 1988, September. Residential Exhaust Equipment. Canada

## 5. REFERENCES

- Mortgage and Housing Corporation.
- 43 Jones, W.R., Wong, M.T., and Jaisareesingh, J., Ontario Hydro Research Division. 1990. Residential thermal comfort and ventilation effectiveness In a full-scale test room. Proceedings of the Conference "Indoor Air Quality : IAQ 1990", Toronto, pp. 305-310.
- 44 Kadulski, R. 1988. Residential Ventilation: Achieving Indoor Air Quality. A Solplan Review Handbook from the Drawing-Room Graphic Services Ltd.
- 45 Linton, J.W. 1986, January. A Comparison of Ventilation Strategies for R-2000 Houses. National Research Council.
- 46 Mattock, C., Rousseau, D.; Habitat Design & Consulting Ltd. 1988, September. A Survey of Ventilation Systems for New Housing. Canada Mortgage and Housing Corporation.
- 47 McDonald, B.; Checker Mfg. Ltd. 1989. Indoor Air Quality Device - IAQD: Phase III, final report. Canada Mortgage and Housing Corporation.
- 48 Melchers, J.; Fodor Engineering Ltd. of Marshall Macklin Monaghan Ltd. 1983. Moisture Induced Problems in NHA Housing, Part 3 : Applicable Moisture Reduction Techniques for Newfoundland. Canada Mortgage and Housing Corporation.
- 49 Moffatt, S., and Sikorski, B., Sheltair Scientific. 1990, November. Integrated Heating and Ventilation Systems: an Air Management Module and Controller for use with Gas-Fired Boilers. Canada Mortgage and Housing Corporation.
- 50 Morofsky, E. Dr.; Parekh, A.; Platts, R.E. Integrated Mechanical Systems: Recent Developments and Potential Housing Applications. Public Works Canada.
- 51 Nakatsui, L., MacKay, V. and Mayhew, W. 1990, December. Dynamic Wall Demonstration Project. Alberta Municipal Affairs.
- 52 National Research Council of Canada. 1984, May. Humidity, Condensation and Ventilation in Houses. Proceedings No.7 of the Building Research Division.
- 53 Newton, A.; Sunton Engineering Ltd. 1987, March. Heating and Ventilation of Modern Housing. Alberta Municipal Affairs.
- 54 Ontario Research Foundation, Energy Systems Centre. 1988, March. Laboratory Evaluation of Rangehood and Bathroom Exhaust Components and Systems. Canada Mortgage and Housing Corporation.
- 55 Piersol, P.; and Matsumura, K.; Ontario Research Foundation. 1987, January. Development of a Procedure to Assess Organic Outgassing from Heat Recovery Ventilators. R-200 Home Program, Energy, Mines and Resources.
- 56 Platts, R.E.; Scanada Consultants Ltd. 1981, May. Field Survey of Moisture-Troubled Walls in Newfoundland Houses. Canada Mortgage and Housing Corporation.
- 57 Product Knowledge Centre, Ontario Hydro. 1988, May. House Ventilation and Air Quality Reference Guide.
- 58 Proskiw, G., Phillips, E.G., Unies Ltd. Figley, D.A., National Research Centre Canada. Fisher, D.R., K.P. Engineering & Design Ltd. 1988, June. Design, Installation and Commissioning of the Ventilation Systems in the Flair Homes Energy Demo/CHBA Flair Mark XIV Project-Report No.3 Energy, Mines and Resources Canada.
- 59 Proskiw, G., Unies Ltd. 1990, July. Observed Performance of the Mechanical Ventilation Systems in Three New Houses. Energy, Mines and Resources Canada.
- 60 Proskiw, G., Unies Ltd. 1990, July. Utilization patterns of residential Mechanical Ventilation Systems. Energy, Mines and Resources Canada.
- 61 Proskiw, G., Unies Ltd. 1990, July. Indoor Air Quality Monitoring of the Flair Homes Energy Demo / CHBA Flair Mark XIV Project. Energy, Mines and Resources Canada.
- 62 Proskiw, G. 1990, July. Observed Variations in Airtightness of Twenty-four Detached Houses Over Periods of Up to Three Years. Energy, Mines and Resources Canada.

## 5. REFERENCES

- 63 Proskiw, G., Unies Ltd. 1991, January. Performance and Costs of Residential Radon Mitigation Measures for Manitoba. Manitoba Environment.
- 64 R2000 Super Energy Efficient Home Program. 1985. Booklet: How to Operate a Heat Recovery Ventilator. Energy, Mines and Resources Canada.
- 65 Raab, K.H. 1982, December. Updating Health Standards for Residential Construction. Canada Mortgage and Housing Corporation.
- 66 Riley, M. 1986, June. Ventilation and Air Quality Monitoring in R-2000 Homes: Measurement and Analysis. R-2000 Home Program, Energy, Mines and Resources Canada.
- 67 Scanada Consultants Limited. 1980, June. Field Investigations of Moisture Related Problems in Nova Scotia. Canada Mortgage and Housing Corporation.
- 68 Semchuk, B. 1985, August. Improved Heating and Ventilating Distribution Techniques. Indian and Northern Affairs Canada.
- 69 Shaw, C.Y.; and Kim, A.; National Research Council Canada. 1984, October. Performance of Passive Ventilation Systems in a Two-Storey House. DBR Paper No. 1276.
- 70 Sheltair Scientific Ltd. 1988, March. Evaluation of the Aereco Ventilation System in the Vis Residence. Canadian Home Builders' Association.
- 71 Sheltair Scientific Ltd. 1989, November. The Canadian Residential Duct and Chimney Survey. Canada Mortgage and Housing Corporation.
- 72 Sinha, R. 1990, February. Demonstration of Integrated Heating and Ventilation Systems. Canada Mortgage and Housing Corporation.
- 73 Star Heat Exchangers. 1988, November. Cross Leakage at HRV Exhaust and Intake Points Test Description and Results.
- 74 Sulatsky, M.; Saskatchewan Research Council. 1984, January. Airtightness Tests on 200 New Houses Across Canada. Energy, Mines and Resources.
- 75 T.E.S. Limited. 1980, March. A Review of Ventilation Requirements for Residential Buildings in Canada. Canada Mortgage and Housing Corporation.
- 76 Talalayevsky, L. 1987, April. Ventilation for Residential Buildings in Northern Conditions. Energy, Mines and Resources Canada.
- 77 Timothy Mayo Communications. 1985, December. Residential Ventilation Requirements - A Research Report. Energy, Mines and Resources.
- 78 Timusk, J.; Seskus, A.L.; Lio, M.; University of Toronto. Performance Evaluation of the Dynamic Wall House. Canada Mortgage and Housing Corporation.
- 79 Timusk, J.; University of Toronto for Marshall Macklin Monaghan Ltd. 1983. Moisture Induced Problems in NHA Housing, Part 2 : Literature Review and Research. Canada Mortgage and Housing Corporation.
- 80 To, K.X.; Venmar Inc. Roof Turbine. National Research Council.
- 81 Trow Inc. 1989, December. Criteria for the Air Leakage Characteristics of Building Envelopes. Canada Mortgage and Housing Corporation.
- 82 Unies Ltd. 1983. An Evaluation of the Effectiveness of Air Leakage Sealing. Manitoba / Canada Conservation and Renewable Energy Demonstration Agreement.
- 83 Unies Ltd. 1988, March. CMHC Guide to Ventilation Systems - Consumers Series. Canada Mortgage and Housing Corporation.
- 84 Van Poorten, J.H.; Marshall Macklin Monaghan Ltd. 1983. Moisture Induced Problems in NHA Housing, Part 1 : Analysis of Field Survey Results and Projections of Future Problems. Canada Mortgage and Housing Corporation.
- 85 Van Poorten, J.H.; Marshall Macklin Monaghan Ltd. 1984, October. Moisture Induced Problems in NHA Housing - Summary Report. Canada Mortgage and Housing Corporation.

## 5. REFERENCES

---

- 86 White, J.H. Requirements for Residential Ventilation Systems and Components. Internal memorandum of the Canada Mortgage and Housing Corporation.
- 87 White, J.H. Canada Mortgage and Housing Corporation. 1984. Separation of Combustion and Ventilation Air. Paper presented at the Marketing Conference of the Canadian Gas Association in Winnipeg.
- 88 White, J.H. 1984, March. Ventilation for Humidity Control. Canada Mortgage and Housing Corporation.
- 89 White, J.H.; Canada Mortgage and Housing Corporation. 1984, June. Ventilation Compliance Tests for Houses. Proceedings of the 77th Annual Meeting of the Air Pollution Control Association, San Francisco, California, U.S.A.
- 90 White, J.H. 1990, November. Comments on CSA F326 Residential Mechanical Ventilation Systems, Second Draft, Revised October 1990. Internal memorandum of the Canada Mortgage and Housing Corporation.
- 91 White, J.H. 1990, December. The energy efficiency of residential ventilation fans and fan/motor sets. Internal memorandum for the Canada Mortgage and Housing Corporation.
- 92 Wilson, A.G.; National Research Council. 1969, February. Ventilation and Air Quality. from the Canadian Building Digest 110.
- 93 Yuill, G.K.; and Comeau G.M.; G.K. Yuill & Associates Ltd. Demonstration and Performance Testing of the Laminar Air Flow Super Window - Humidity Controlled Air Inlet - Baseboard Heating (LAFSW/HCAI/BH) System in a Winnipeg House. Energy, Mines and Resources.

