

6039

International Symposium on Room Air Convection and Ventilation Effectiveness
University of Tokyo, July 22 - 24, 1992

Measurements of Contaminant Dispersion in Ventilated Rooms by a Passive Tracer Gas Technique



Per Heiselberg
University of Aalborg
Sohngaardsholmsvej 57
DK-9000 Aalborg
Denmark

Niels C. Bergsøe
Danish Building Research Institute
P.O. Box 119
DK-2970 Hørsholm
Denmark

ABSTRACT

During recent years the interest in the passive tracer gas technique has grown rapidly. The method has mainly been used in the field for measurements of air infiltration rates in buildings. This paper describes measurements of the contaminant dispersion in a ventilated room using a passive tracer gas technique and the results are compared with the results from a conventional method.

Vertical profiles of concentration in the middle of the room have been measured at different ventilation air flow rates and different locations of the tracer gas source. The results showed good correspondence between the methods within an accuracy of $\pm 10-15\%$ in large parts of the room. In regions close to the tracer gas sources the differences were larger. The results gave at the same time recommendations for the use of the passive tracer gas technique for measurements of the air infiltration rates in buildings.

KEY WORDS Passive Tracer Gas Technique, Contaminant Dispersion

INTRODUCTION

Knowledge of the air distribution and the air flow inside buildings in use is only possible by use of measurement techniques. During recent years the interest in the passive tracer gas technique has grown rapidly because it is a simple, easy to use and an inexpensive method compared with traditional tracer gas methods. Also the possibility of simultaneous use of several different tracer gas types and the fact that measurements can be performed as long term measurements makes the technique interesting in connection with investigations in the field.

The principles for this technique were developed at the Brookhaven National Laboratories (Dietz et al. 1986) in the beginning of the 1980'es. Since then the method has been used mainly for measurements of ventilation air infiltration rates in buildings

and results have been reported by several investigators, (Bergsøe 1988; Harrje et al. 1988; Sateri et al. 1989; and Sateri 1991).

This paper describes laboratory tests where the passive tracer gas technique has been used for measurements of the contaminant dispersion in a ventilated room at different air flow rates and different locations of the tracer gas source. The results are compared with the results from a conventional method. The comparison shows the ability of the passive tracer gas method to register concentration differences in a ventilated room and the measurements give at the same time information about the degree of complete mixing in the room.

EXPERIMENTAL SET-UP

The measurements have taken place under isothermal steady state conditions in a full-scale test room located in a laboratory hall. A sketch of the geometry of the room is shown in figure 1. The inlet is located in the middle of one of the end walls with the top of the diffuser 2.2 m above the floor, see figure 1. The dimensions are ($H \times W$) = (0.17 m \times 0.7 m). The generated flow pattern is very typical of modern air terminal device design. The outlet is located below the inlet with the top of the outlet at a distance of 1.6 m above the floor. The dimensions are ($H \times W$) = (0.2 m \times 0.3 m).

The contamination source consists of a ping pong ball (diameter 30 mm) with 6 evenly distributed holes with a diameter of 1 mm each. CO₂ was used as a contaminant. It was mixed with the carrier gas He in order to give the contaminant the same density as air. The total contaminant flow rate was 0.025 l/s. The measurements of profiles of concentration are based on measurements in 10 points. The points were distributed along a vertical line placed in the centre plane of the test room 2.2 m from the supply opening.

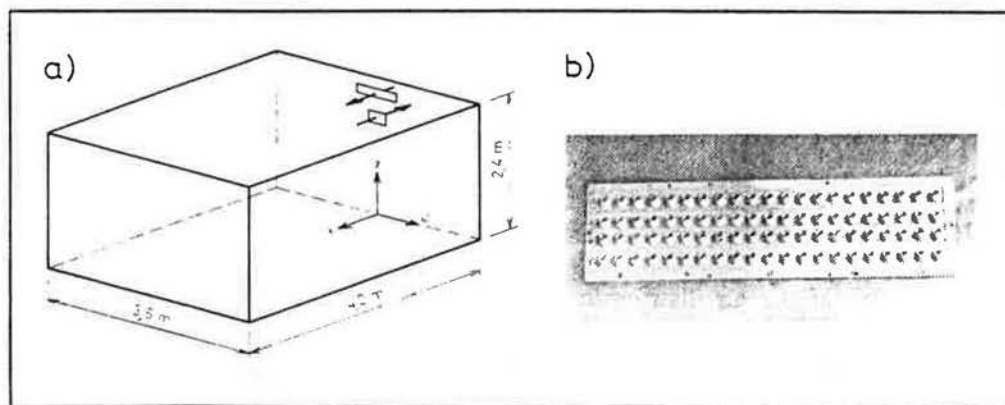

Figur 1. a) Sketch of the geometry of the full-scale test room. b) Close-up of the HESCO inlet device.

PROFILES

The co
different loc
the concentr
and a conve
tion ratios w

Influence of

The pro
source is loc
1.2 m above
rate is appr
of the jet is
is below 0.1
case where
jet is here a
occupied zo
office. In th
occupied zo
et al. (1990)

The res
distribution
primary air.

In the c
rate and it c
h⁻¹ due to a
the supply a
flow takes p
exchange of
rate of n=3
recirculatin
be almost i
becomes ve
other air in
Heiselberg
a low veloc
imating the
is independ
occupied zo
contaminar

The re
of n=3 h⁻¹
except clos

PROFILES OF CONCENTRATION

The contaminant dispersion in a ventilated room at different air flow rates and different locations of the tracer gas source is evaluated in the light of vertical profiles of the concentration in the middle of the test room. Both the passive tracer gas technique and a conventional technique have been used. The profiles are presented as concentration ratios where the reference concentration is the concentration in the exhaust opening.

Influence of Air Change Rate

The profiles for three air change rates are shown in figure 2. The contamination source is located in the centre plane of the test room 2.2 m from the supply opening and 1.2 m above the floor. In the test case with an air change rate of $n=1.5 \text{ h}^{-1}$ the air flow rate is approximately the minimum value required to ventilate an office room. The throw of the jet is about 4/5 of the room length and the maximum velocity in the occupied zone is below 0.1 m/s. The test case with an air change rate of $n=3 \text{ h}^{-1}$ represents the basic case where the air flow rate is about the usual value in office rooms. The throw of the jet is here approximately room length plus room height and the maximum velocity in the occupied zone is 0.16 m/s which is the maximum velocity that can be accepted in an office. In the test case with an air change rate of $n=6 \text{ h}^{-1}$ the maximum velocity in the occupied zone is about 0.33 m/s. The velocity measurements can be seen in Skovgaard et al. (1990).

The results in figure 2 show in the upper part of the room a concentration distribution in the wall jet created by entrainment of the contaminated room air into the primary air. The distribution is nearly the same for all three air change rates.

In the occupied zone the concentration distribution is dependent on the air change rate and it changes radically when the air change rate is changed from $n=1.5 \text{ h}^{-1}$ to $n=3 \text{ h}^{-1}$ due to a change in the flow structure in the room. At an air change rate of $n=1.5 \text{ h}^{-1}$ the supply air jet only reaches the upper part of the occupied zone and the recirculating flow takes place here. In the lower part of the room there are small velocities and a slow exchange of air and therefore a high relative concentration of about 2. At an air change rate of $n=3 \text{ h}^{-1}$ the supply air jet reaches the floor in the room and there will be a recirculating flow with large velocities at floor level. The contamination source will then be almost in the centre of the recirculating flow and the relative concentration therefore becomes very high up to 3-4 before the contaminant is entrained and discharged with the other air in the room. Model experiments by Oppl (1969) and full-scale experiments by Heiselberg et al. (1987) show a similar effect when the source is placed in an area with a low velocity. With an increasing air change rate the contaminant distribution is approximating the distribution at high turbulent flow conditions in the room. This distribution is independent of the air change rate, see Nielsen (1981). The maximum velocity in the occupied zone will, however, be above the acceptable comfort level for office rooms. The contaminant distribution in a room will in practice therefore depend on the air flow rate.

The results show good correspondance between the two methods at air change rates of $n=3 \text{ h}^{-1}$ and $n=6 \text{ h}^{-1}$. In large parts of the room the accuracy is within $\pm 10-15\%$, except close to the sources because of the differences in the release of tracer.

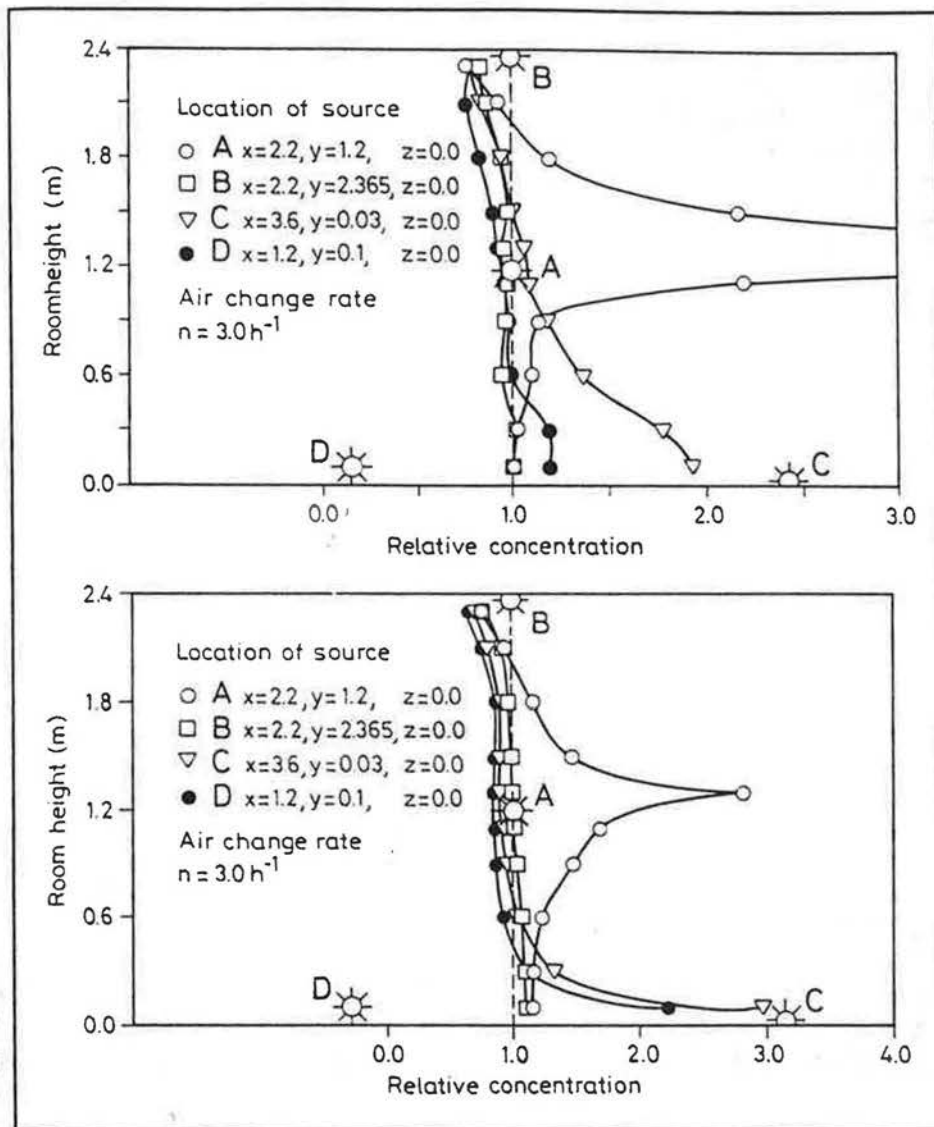

Figure 3. Relative concentration profiles for four different locations of the contamination source found by A) a passive tracer gas method and B) a conventional tracer gas method.

middle of the room gives high relative concentrations there as mentioned above. A location in the primary jet results in a very good mixing of the contaminant and the supply air and gives a quick removal of the contaminant and a homogeneous contaminant distribution in the whole room with a relative concentration close to 1. A location of the contamination source at floor level gives a uniform concentration in the upper part of the room with a relative concentration of about 1 and only high concentration in the immediate vicinity of the floor. Corresponding results are found by Oppl (1969) and Nielsen (1981).

DISCUSSION

In a room with incomplete mixing measurements of the air change rate will depend on the location of the measurement points. A location too close to the contamination source will result in measuring of relatively small air change rates, while a location close to the air inlet will result in measuring of relatively large air change rates. The results in this paper show that in certain situations the air change rates can be 3-4 times as large in some areas of the room than in others. The best estimation of the air change rate will be achieved if the measurement points are located in areas of the room where the air is leaving the room or by an even distribution of measurement points in the whole room.

The concentration differences in a room depend among other things on the location of the contamination source and of the flow conditions in the room. A homogeneous contaminant distribution is achieved if the contamination source is located in an area of the room where the velocity is high and the exchange of air is large. The contaminant will then be well mixed with the flowing air and quickly be distributed in the whole room. On the other hand if the contamination source is located in an area of the room where the velocity is low and the exchange of air is small, then the concentration of the contaminant becomes very high before it is entrained and discharged with the air in the room and there will be large differences in the concentration of the contaminant between the different parts of the room.

The results show that the flow conditions in a room are changing when the air change rate are changed and that the larger the air change rate is the more homogeneous the contaminant distribution will be. Therefore it will not be in the same areas of the room that relatively high and relatively low air change rates will be measured when the air change rate changes.

CONCLUSION

The results reported in this paper show that it is possible to register concentration differences in a room with a passive tracer gas method and that the accuracy of the method compared with a conventional method is within $\pm 10-15\%$ in large parts of the room.

In a ventilated room the distribution of contaminants will depend on both the ventilation principle, the location of the contamination sources and the supplied air flow rate. The experiments reported here have shown that in the laboratory test room a high air change rate and a location of the contamination sources in areas of the room with a high air velocity will only cause small differences in concentration in the room.

In a room with incomplete mixing measurements of the air change rate will depend on the location of the measurement points. The best estimation of the air change rate will be achieved if the measurement points are located in areas of the room where the air is leaving or by an even distribution of measurement points in the whole room.

REFER

Bergsøe
Danish)

Dietz, R
and Per.
and Air
H. R. T
Philadel

Harrje, I
Building
Confere:
Coventry

Heiselbe
Room w
Stockhol

Nielsen,
and Two

Oppl, L
914.

Sateri, J
Passive
PROC-1

Sateri, J
NBS-I 1

Skovgaard
Measur
ROOM

REFERENCES

Bergsøe, N. C. 1988. New Track Gas Measuring Method for Air Change Measurements (in Danish). VVS Denmark, Vol. 24, No. 8, pp. 10-12.

Dietz, R. N. ; Goodrich, R. W. ; Cote, E. A. and Wieser, R. F. 1986. Detailed Description and Performance of a Passive Perfluorocarbon Tracer System for Building Ventilation and Air Exchange Measurements. Measured Air Leakage of Buildings, ASTM STP 904, H. R. Trechsel and P. L. Lagus, Eds., American Society for Testing and Materials, Philadelphia, pp. 203-264.

Harrje, D. T. ; Bohac, D. L. and Feuermann, D. 1988. Extended Testing of a Multifamily Building using Constant Concentration and PFT Methods. Proc. of the 9th AIVC Conference, Document AIC-PROC-9-88-1, AIVC, University of Warwick Science Park, Coventry, Great Britain.

Heiselberg, P. and Nielsen, P.V. 1987. The Contaminant Distribution in a Ventilated Room with Different Air Terminal Devices. Proc. of the Int. Conf. ROOMVENT '87, Stockholm.

Nielsen, P.V. 1981. Contaminant Distribution in Industrial Areas with Forced Ventilation and Two-dimensional Flow. IIR-Joint Meeting, Commission E1, Essen.

Oppl, L. 1969. Luftströmung in Gelüfteten Räumen. Öl- und Gasfeuerung, Nr. 9, pp. 908-914.

Sateri, J. ; Jyske, P. ; Majanen, A. and Seppanen, O. 1989. The Performance of the Passive Perfluorocarbon Method. Proc. of the 10th AIVC Conference, Document AIC-PROC-10-89-1, AIVC, University of Warwick Science Park, Coventry, Great Britain.

Sateri, J. (editor) 1991. The Development of the PFT-method in the Nordic Countries. NBS-I 1991. Document D9:1991, Swedish Council for Building Research.

Skovgaard, M. ; Hyldgaard, C.E. and Nielsen, P.V. 1990. High and Low Reynolds number Measurements in a Room with an Impinging Isothermal Jet. Proc. of the Int. Conf. ROOMVENT '90, Oslo.