



#5372

**Field Investigation Survey of  
Air Tightness, Air Movement and  
Indoor Air Quality in  
B.C. High-Rise  
Apartment Buildings**

**FINAL REPORT**

for

Jacques Rousseau  
Project Implementation  
**CANADA MORTGAGE AND HOUSING CORPORATION**  
National Office  
682 Montreal Road  
Ottawa, Ontario  
K1A 0P7

**File Number:**

6791-19-1/5

by

Bob Landell  
**AVALON MECHANICAL CONSULTANTS LTD.**  
#4-1322-A Government Street  
Victoria, B.C.  
V8W 1Y8  
(604) 384-4128

**July 15, 1991**



Canada Mortgage and Housing Corporation, the Federal Government's housing agency is responsible for administering the National Housing Act.

This legislation is designed to aid in the improvement of housing and living in Canada. As a result, the Corporation has interests in all aspects of housing and urban growth and development.

Under Part IX of this Act, the Government of Canada provides funds to CMHC to conduct research into the social, economic and technical aspects of housing and related fields, and to undertake the publishing and distribution of the results of this research. CMHC therefore has a statutory responsibility to make widely available, information which may be useful in the improvement of housing and living conditions.

This publication is one of the many items of information published by CMHC with the assistance of federal funds.



**DISCLAIMER**

This project was funded by the Canada Mortgage and Housing Corporation (CMHC). The views expressed are the personal views of the authors, and do not necessarily represent the views of CMHC.

**ACKNOWLEDGEMENTS**

Avalon Mechanical Consultants would like to acknowledge CMHC, the owners and managers of the 5 studied buildings, Scott Technical Services, Island Energy Inc., Scanada Consultants, Allied Glass and CHBA for their contributions to the work.





**TABLE OF CONTENTS**

	Pg
Disclaimer.....	i
Acknowledgements.....	i
Table of Contents.....	ii
Abstract.....	iii
1.0 Executive Summary.....	1
2.0 Introduction.....	2
3.0 Background	
3.1 Typical Construction & HVAC.....	3
3.2 Air Movement in High-Rise Apts.....	5
3.3 Ventilation Induced Problems.....	6
3.4 Moisture Problems.....	6
3.5 Climate and Lifestyle.....	7
4.0 Discussion	
4.1 Air Test Methodology.....	8
4.2 Test Conditions.....	9
4.3 Air Tightness Results.....	13
4.4 Air Tightness.....	14
4.5 Indoor Air Quality.....	19
4.6 Moisture Problems.....	21
5.0 Conclusions	
5.1 Air Tightness.....	22
5.2 Indoor Air Quality.....	23
5.3 Moisture Problems.....	23
5.4 Mechanical Ventilation.....	24
5.5 Overall Ventilation.....	24
5.6 Air Leakage Test Protocol.....	24
<b>APPENDICES.....</b>	<b>26</b>
A. Drawings of, & Photographs From Studied Buildings.	
B. Occupant Questionnaires & Building Checklists.	
C. Air Leakage Test Equipment.	
D. Air Leakage Test Monitoring Results.	
E. Field Data From Air Leakage Tests.	
F. IAQ Monitoring Results.	
G. Annual Meteorological Summary for Victoria.	



**ABSTRACT**

The following report is entitled Field Investigation Survey of Air Tightness, Air Movement, and Indoor Air Quality in British Columbia High-Rise Apartment Buildings.

This project is intended to provide information concerning the following:

- a) air leakage in 3 sample high-rise apartment buildings
- b) air movement patterns within the 3 buildings
- c) indoor air quality (IAQ) within high-rise apartment buildings

A total of 5 buildings were studied. Their general attributes are as follows:

**Building "A"**

11 floors, 74 suites, electric baseboard heat, built 1984.

**Building "B"**

8 floors, 28 suites per tower, electric baseboard heat, built 1991.

**Building "C"**

10 floors, 30 suites, electric baseboard heat, built 1991.

**Building "D"**

7 floors, 16 suites, electric baseboard heat, built 1982.

**Building "E"**

10 floors, 138 suites electric baseboard heat, built 1976.

Air leakage testing was performed on buildings "A" "B" and "C."

IAQ evaluations were performed on buildings "A" "D" and "E."

Sketches of buildings can be seen in Appendix "A."



## **1.0 EXECUTIVE SUMMARY**

.1 The general findings of this study, with respect to air leakage, are summarized as follows:

- .1 The rates of leakage in apartment buildings can vary considerably from building to building, and from floor to floor within a particular building.
- .2 Of the 5 floors whose depressurization test data has sufficiently high correlation coefficients, 4 have similar rates of leakage. The average Normalized Leakage Area (NLA) for these 4 new floors is 1.25 cm<sup>2</sup> per m<sup>2</sup> of envelope area. This is 1.8 times greater than the maximum allowable NLA for R-2000 houses.

The remaining floor had an NLA of 3.17 cm<sup>2</sup> per m<sup>2</sup> of envelope area. The above results are based upon calculations as per CAN/CGSB-149.10-M86.

.3 The greatest sources of air leakage into the floors, from most to least, are generally as follows:

- Elevator shafts
- Floors & ceilings
- Stairwell doors
- Sliding glass patio doors
- Suite fans with ineffective backdraft dampers
- Windows
- Various other service shafts.

.2 With regard to Indoor Air Quality (IAQ), numerous minor problems were encountered, but conditions are generally very good in these buildings.

The only potentially serious problem discovered occurs in building "D." Poor garage ventilation results in relatively high concentrations of carbon monoxide within the building. Spot testing showed CO levels in excess of unofficial comfort levels in the lobby and on the top floor. The concentration in the lobby was equal to the Health and Welfare Canada Residential Exposure Guidelines for 8 hour exposure.

.3 Moisture problems associated with rain penetration were encountered in all 3 occupied buildings. There were very few other moisture-related problems discovered.

.4 The protocol used for air leakage testing in this project is difficult to implement, particularly in large occupied buildings. Occupant concerns and wind conditions can easily prevent proper test conditions and data collection.



**ENQUETE SUR L'ÉTANCHÉITÉ À L'AIR, LES MOUVEMENTS D'AIR ET LA QUALITÉ DE L'AIR INTÉRIEUR DANS LES TOURS D'HABITATIONS DE LA COLOMBIE-BRITANNIQUE**

Le rapport renseigne sur les aspects suivants :

- l'étanchéité à l'air de trois tours d'habitation;
- la tendance des mouvements d'air dans les trois bâtiments; et
- la qualité de l'air à l'intérieur des trois tours.

L'étude a porté sur cinq tours d'habitation, comptant entre sept et onze étages. Deux bâtiments dataient du début des années 1980 et trois étaient neufs; le chauffage était assuré dans tous les cas par plinthes électriques.

Voici les résultats généraux obtenus de l'étude en matière d'étanchéité à l'air :

- le taux de fuite des immeubles d'appartements peut varier considérablement d'un bâtiment à l'autre, de même que d'un étage à l'autre à l'intérieur d'un bâtiment donné.
- Parmi les cinq planchers dont la dépressurisation comportait un coefficient de corrélation suffisamment élevé, quatre enregistraient des taux de fuite semblables. La surface de fuite normalisée (SFN) de ces planchers correspondait à 1.25 cm<sup>2</sup> par m<sup>2</sup> de l'enveloppe. Cela représente un taux de 1.8 fois supérieur à la SFN admissible d'une maison R-2000.

Le reste du plancher avait une SFN de 3.17 cm<sup>2</sup> par m<sup>2</sup> de l'enveloppe. Les résultats précédents sont fondés sur les calculs que renferme la norme CAN/CGSB-149.10-M86.

- Les plus importantes sources de fuite des étages, s'expriment généralement comme suit, par ordre décroissant :

- Cages d'ascenseurs
- Planchers et plafonds
- Portes d'accès aux cages d'escaliers
- Portes-fenêtres coulissantes
- Ventilateurs des appartements sans registres antirefoulement efficaces
- Diverses gaines techniques.

Différents problèmes mineurs se sont manifestés sur le plan de la qualité de l'air intérieur, mais en général les bâtiments affichaient une qualité de l'air très élevée. Le seul point relevé qui risque de devenir sérieux concerne la ventilation médiocre du garage qui donnait lieu à des concentrations



relativement élevées de monoxyde de carbone (CO) dans l'un des bâtiments. Des prélèvements ponctuels ont permis de découvrir des concentrations de CO dépassant le niveau officieux de confort dans le hall d'entrée et au dernier étage. La concentration enregistrée dans le hall d'entrée équivalait à ce que prévoient les directives d'exposition de Santé et Bien-être social Canada pour une période de 8 heures. Des problèmes d'humidité attribuables à l'infiltration de l'eau de pluie ont été relevés dans les trois bâtiments, mais très peu d'autres méfaits dus à l'humidité.

Les essais d'étanchéité à l'air ont été effectués selon la procédure énoncée dans le document de la SCHL intitulé Établissement des méthodes de mesure de l'étanchéité à l'air et des mouvements d'air dans les tours d'habitation. Les méthodes se sont révélées difficiles à adopter, surtout dans de grands bâtiments occupés. L'inquiétude des occupants et les vents peuvent nuire grandement aux conditions d'essai et au rassemblement de données.

**CMHC**

**Helping to  
house Canadians**

National Office

700 Montreal Road  
Ottawa, Ontario  
K1A 0P7

**SCHL**

**Question habitation,  
comptez sur nous**

Bureau National

700 chemin Montréal  
Ottawa (Ontario)  
K1A 0P7

*Puisqu'on prévoit une demande restreinte pour ce document de recherche, seul le sommaire a été traduit.*

*La SCHL fera traduire le document si la demande le justifie.*

*Pour nous aider à déterminer si la demande justifie que ce rapport soit traduit en français, veuillez remplir la partie ci-dessous et la retourner à l'adresse suivante :*

*Le Centre canadien de documentation sur l'habitation  
La Société canadienne d'hypothèques et de logement  
700, chemin de Montréal, bureau C1-200  
Ottawa (Ontario)  
K1A 0P7*

**TITRE DU RAPPORT:** \_\_\_\_\_  
\_\_\_\_\_

*Je préférerais avoir ce rapport en français.*

**NOM** \_\_\_\_\_

**ADRESSE** \_\_\_\_\_  
rue app.

-----  
ville province code postal

**No de téléphone** ( ) \_\_\_\_\_

CMHC  
1991  
SCHL  
1991

TEL: (613) 748-2000

Canada Mortgage and Housing Corporation

Société canadienne d'hypothèques et de logement

Canada



## **2.0 INTRODUCTION**

In many high-rise apartment buildings (including those studied herein), air leakage through exterior walls, between units, and to and from service chases provides the majority of ventilation. Unplanned leakage can result in problems with IAQ, moisture, energy costs, and ventilation. Life safety may even be a concern if fire barriers are not well sealed against smoke passage. The purpose of this study is to determine the amount of air and moisture leakage in 3 high-rise apartments, and to study the impact that these rates have on indoor air quality (IAQ).

Three apartment buildings, each 8 floors or more in height, were tested for air leakage and movement, and 3 have been evaluated for indoor air quality. The buildings are all located in Victoria.

A "walk-through" inspection was performed for the purposes of determining the following:

- building structure/architectural details
- suite layout, furnishings & equipment details
- HVAC details
- factors affecting Indoor Air Quality (IAQ)

Assessment Checklists and Questionnaires have been tabulated; see Appendix "B."

Problem areas with respect to IAQ, moisture migration into walls, and air leakage have been identified by objective evaluation and by interview/questionnaire of building management and occupants where possible.

Tests were conducted to determine the air tightness values of exterior walls and floor/ceiling separations of individual storeys in 3 buildings. The methodology employed is as outlined in Section 4.1, the equipment is shown in Appendix "C," and the results are presented in Appendices "D" and "E."

Smoke pencils were used to investigate air movement and areas of air leakage.

Comfort and air quality was evaluated through inspection as well as the above-mentioned questionnaires. In general terms, the IAQ of these buildings is very good. Building "A" is a non-profit society's Senior Citizens' building which was built to CMHC standards. Building "D" is a condominium located in a desirable area and occupied largely by seniors, and Building "E" is well managed and large enough to have both in-house maintenance, and private service contracts. The quality of these buildings and their operation is, quite possibly, well above average.

Where there was reason to suspect an IAQ problem, monitoring of contaminants was carried out. In Building "D," for example, CO measurements were taken throughout the building starting at 9:00 am on a weekday because auto fumes were reported in the questionnaires, and because the building rests on an enclosed parkade. Because no auto activity had taken place, a car was left to idle for 15 minutes, then readings were taken again. Similar testing was performed at the Building "E." Results are presented in Appendix "F."

### **3.0 BACKGROUND**

#### **3.1 Typical High-Rise Apartment Construction and HVAC Systems**

New residential high-rise construction (Group C buildings over three storeys in height) in the southern Vancouver Island area is predominantly reinforced concrete structure with metal stud frame partitions and cladding.

Current insulation levels are typically RSI 2.1 in walls and variable in roofs. Sloped metal roofs are becoming popular due to aesthetics, performance, longevity, and ease of insulation.

Windows are normally double glazed metal frame units. Better quality construction projects will include window units with a thermal break in the metal frame. Sliding, casement and awning windows without bug screen protection are typical and well accepted as adequate for the climatic conditions.

The air tightness of buildings has been increasing over the past decade, but no testing or enforcement are applied to Part 3 buildings in BC. Parts 5.2, 5.3 and 5.4 of the BC Building Code contain general requirements for continuous vapour barrier, effective air barrier, and rain penetration respectively.

Unlike many large office buildings containing large interior core areas, apartments usually have windows in all well-occupied rooms. Traditionally, ventilation air has been supplied through opening windows and by way of natural or mechanically induced infiltration. Because of the mild climate, many buildings in the past did not include mechanical exhaust fans, in favour of operable windows which provide for short term ventilation requirements.

Natural ventilation due to the temperature difference between the interior and exterior environments (stack effect) is less than exists in other parts of Canada because of Victoria's mild climate. The older housing stock was extremely leaky as compared to the rest of the country.

Mechanical ventilation is now common; in suites, it is usually limited to standard bathroom and kitchen exhaust fans. Many buildings now have outdoor air inlet grilles for each suite.

Hall pressurization fans are required to provide make-up air and reduce cross flow between suites. These fans seldom had operable heaters prior to 1985. Most systems are now equipped with heaters, but they are often turned off for reasons of economy or comfort, at least for periods of cold weather. Supplement #2 to the Building Code contains measures for smoke control and it outlines options for ventilation design. Stairwells and lobbies are pressurized and garbage chutes are usually vented passively at the roof. Laundry rooms may have exhaust systems; special attention to lint filtration is required. If enclosed garages are within the building, fans capable of exhausting 3.9 L/s per m<sup>2</sup> of parkade are required. These fans can be controlled by carbon monoxide sensors to maintain less than 100 ppm CO. When CO sensors are used, the required exhaust air volume can be halved.

Oil-fired hydronic heat has been replaced as the common space heating system by electric baseboard heat. Types other than electric baseboard can still be found however; often in higher quality buildings. Heating costs in centrally heated buildings are bulk metered and apportioned by area. Temperature control is often poor in these buildings, and windows are often open during cold weather. Heating costs in electric baseboard buildings are individually metered by suite, and zone control is more effective. Windows are opened less in baseboard buildings.

Natural gas is expected to be available on the Island in 1992, but the impact of this development on residential buildings is not expected to be great (beyond domestic hot water application) unless incentives are provided by utilities or government.



### **3.2 Air Movement In High-Rise Apartments**

Air movement in buildings results from pressure differences caused by the algebraic sum of wind effect, stack effect and HVAC pressurization.

**Wind effect** varies with wind velocity, wind direction, and the number and size of penetrations in the exterior wall assembly. Wind can produce a positive pressure on one or two orientations and a negative pressure on the remaining orientations. The air flow caused in tall buildings is largely horizontal. Wind effect can be strong enough to overcome the pressure created by the hall pressurization fan. Wind effect can cause significant crossflow between suites, particularly if hall pressurization fans are turned off.

**Stack effect** results in air infiltration to lower floors and air exfiltration from upper floors. It varies with temperature difference between indoors and outdoors, the barriers to upward flow within the building, and the number and size of openings in the exterior wall assembly (both above and below the neutral pressure plane). The maximum stack pressure at Victoria's winter design conditions for buildings of the height of those studied herein is approximately 20 Pa. The air flow it causes is largely vertical; upward during cold weather, and downward during very warm Victoria weather. Migration of auto fumes from enclosed garages, and contamination from basement garbage rooms can be increased by stack effect. Comfort can be affected by stack effect; for example drafts felt on lower floors can cause occupants to raise thermostat setpoints. The resultant increased flow of warm air into upper suites from below can cause opening of upper windows, which in turn causes increased drafts below.

Maximum wind effect is much larger than the maximum stack effect, but the average stack effect is larger than the average wind effect.

**HVAC pressurization** in high-rise apartments can be positive, as in the case of the hallway pressurization fans, or negative, as in the case of garage fans, suite kitchen fans, bathroom exhaust fans or fireplaces. The volume of pressurization is usually in the order of 25 lps per suite. Total mechanical air distribution per m<sup>2</sup> of floor area is usually about 10% of what exists in high-rise office buildings.

### **3.3 Ventilation-Related Problems**

The combination of circumstances described above has created apartments which receive large amounts of natural ventilation under average conditions. Although this results in very few IAQ problems, the uncontrolled and non-uniform distribution of outside air in apartment buildings has resulted in moisture problems, typically exhibited on interior surfaces at the ceiling/external wall junctions, beneath dripping window ledges, throughout bathroom interiors, and in cool, unventilated storage spaces.

Mould and mildew are much less common than in single family dwellings, but can be found on window surfaces, in bathrooms and closets, along baseboards and in grouting around bathtubs and sinks. High occupancy can aggravate this condition. Furthermore, the zone heating allowed by electric baseboards often increases temperatures only in rooms where required. This situation can result in mould and mildew growth in unoccupied areas because of the low temperature and condensed humidity.

In apartments without mechanical exhaust systems, ventilation during the summer months can be inadequate because of the reduction of natural infiltration. The ambient summer temperature hovers close to room temperature and there is little temperature difference to force air change through the stack effect. Wind speeds are also lowest during the summer months and less capable of contributing to natural infiltration.

Cross contamination between suites can occur when hall pressurization fans are turned off. In addition, if the fan is on, but the majority of bathroom exhaust fans and/or kitchen hoods are operating, cross contamination can still occur. The wind can further aggravate this situation.

### **3.4 Moisture Problems**

Moisture problems can result from condensation, rain penetration or flooding. Microbiological and mycological contamination can proliferate in moist environments, and construction materials can be degraded by moisture.

Condensation on or within exterior envelopes varies with the air leakage rate, the moisture content of the air, and the temperature drop undergone by the air. Much water is admitted to the air of residences, and the exterior of a well insulated wall can be within a few degrees of very cold outdoor temperatures. Coastal BC has a moderate climate; therefore the effects of condensation will be less in Victoria or Vancouver than might exist in other parts of Canada. Judging from the findings of this study, air leakage, however, appears to be high. Condensation on structural and subassembly steel can result in rust and corrosion. This is likely to be more prevalent in the upper storeys of buildings.



Some degree of rain penetration was seen in the three oldest buildings studied. The wetting of walls depends on wind strength, wind direction and intensity of rain. Once rain contacts a wall, its movement is a result of the forces of gravity, wind and capillary action. The integrity of the wall and its internal cavity dictates whether water penetration becomes a problem.

There are many possible sources of water entry. Concrete buildings can move or settle and cracks can result. Water can enter seams, for instance where walls are poured on top of floors etc. Improper installation of "re-bar" can allow contact with water, rusting, freezing and cracking. Mortar deterioration can also be a problem in block or brick buildings. Stucco buildings will admit water if not properly sized or painted. Leakage can occur around windows if they are not papered properly, and "sliders" are more susceptible to water penetration than exterior glazed awning windows.

Flooding is a concern in residential occupancies, but overflow fittings on lavatories and bathtubs have reduced incidences. The only overflow noted at any of the buildings was in connection with a washing machine in the common laundry room.

### **3.5 Climate and Lifestyle**

The Victoria area climate is described as a mild maritime climate. The normal degree days below 18 degrees celsius are 3,115. The 99th percentile design temperature is minus 7 degrees celsius. Average relative humidity in the summer months is 79 percent, and average relative humidity in the winter months is 86 percent. The heating season extends from October through April and is generally mild with considerable cloudiness and periods of rain. A full description of the local climate is attached as Appendix "G," and includes meteorological data for two weather stations; the Victoria International Airport and at the Gonzales Heights locations.

As described above, ventilation has traditionally been accomplished by a combination of minimal mechanical exhaust systems and operable windows. The current price of electricity (approximately \$0.06/kWh), reduces the desirability of providing constant ventilation through open doors or windows.

The concept of continuous, controlled suite ventilation has had limited exposure in this market place, although de-humidistats are now becoming common for bathroom exhaust fans.

#### **4.0 DISCUSSION**

Air tightness testing was carried out according to the procedures outlined in the CMHC document entitled Establishing The Protocol for Measuring Air Leakage and Air Flow Patterns in High-Rise Apartment Buildings, Test 1g.

#### **4.1 Air Tightness Test Methodology**

- .1 Overall: A variable speed de-pressurization fan, controlled by a microprocessor to maintain a pressure differential between outdoors and indoors, was temporarily installed in the stairwell door of the "test floor." De-pressurization fans were temporarily installed for the floors above and below the test floor. These floors are referred to as the "balance floors." Balancing, to eliminate pressure differential between the test and balance floors, was done through use of two-way radios.

A factory calibrated velometer, produced for this project, was installed in a specially fabricated bell mouth. This velometer was interfaced with our microprocessor data acquisition panel to accurately record air flow exiting the test floor at various building pressures. Data was written directly to disk during various tests. All elevators, chutes and stairwells were sealed and both balance fans were on initially. Tests were conducted to determine the effects of unsealing these items, and tests were done with only one balance fan in operation.

- .2 Air Flow Measurement: The design of suitable test apparatus for this project presented some challenging problems. The requirements of the air movement and measurement equipment are summarized below:

- Must have sufficient flow capacity to meet the maximum anticipated infiltration rates.
- Must be compact and portable.
- Must not consume more power than is readily available on site.
- Must be accurate over a large air flow range.
- Must interface with the micro-processor controller for both capacity adjustment signal (controller output) and air flow signal (controller input).
- Must be cost effective.
- All components must be available on short delivery.

The limitations of readily available site power effectively limits the size of the fan motor to one horsepower. One of the sub-contractors possesses a one horsepower adjustable speed DC motor controller system which was used as a component of their in-house wind tunnel. With minor modifications, this system

operated from the standard 0-10 volt output signal generated by the micro-processor controller. It was decided to use this to drive the main test fan. Because they are relatively light and efficient and are readily available, it was decided to use forward-curved single inlet centrifugal fans for the main test fan and the balance fans.

In order to achieve a flow measure plane with an even velocity profile it was decided to use a parabolic intake bell with a throat dimension of one square foot. The square section was selected in preference to a round section in order to maximize space utilization and for ease of fabrication.

The accuracy of instrumentation which relies on velocity pressure for flow signal becomes very unreliable at lower ranges, especially when field instrumentation is used. Chapter 13 of the 1989 ASHRAE Fundamentals Handbook indicates that velocity measurement by pitot tube is limited to a low end range of 3 m/s. It also states that precision manometers are "essential" at velocities lower than 7.6 m/s. Precision manometers are not suitable for field use, especially when there is a potential for fluctuating velocity pressures. It was therefore decided to use an electronic thermal anemometer with linear output characteristics as the flow sensing transducer. An NBS traceable calibration certificate is included in Appendix "C." A single point velocity sensing transducer is mounted in the centre of the measurement plane. During the commissioning tests, the actual velocity profile was determined at the centre of nine equal areas within the test section at seven nominal flow rates throughout the anticipated operating range of the apparatus. These velocities were determined using a portable analogue thermal anemometer. Variations in velocity profile across the test plane were found to be plus or minus 8% of average; centre point velocity was within 1% of average.

#### **4.2 Air Tightness Test Conditions**

##### **.1 Test Floor General Conditions**

All windows locked.  
All interior doors open.  
Stairwell doors initially sealed.  
All suite fans off, but not sealed.  
Garbage chute initially sealed.  
Hall pressurization fan turned off; outlet sealed.  
All elevators initially sealed.  
Fireplaces unsealed (except Floor C5) as per CAN/CGSB-149.10-M86

The suite fans were not sealed so that the test protocol matched the protocol used in Ontario by Scanada Consultants.

For certain tests, one of the floors (usually a balance floor) could not be de-pressurized to 50 Pa. For these, recordings were taken to the highest possible level of de-pressurization.

**.2 Building "A"**

The first blower door test was performed at building "A" on March 28, 1991. This building contains 2 elevators, a garbage chute, but no fireplaces.

Air leakage measurements were taken at various levels of depressurization under the following conditions:

- all fans on,
- each balance fan off and sealed,
- 1 elevator unsealed,
- 1 elevator plus the garbage chute unsealed,
- 1 elevator, the garbage chute plus one stairwell unsealed.

Wind Data:

The test day was very windy, and the wind was gusty. This was particularly significant as the building is high on a hill overlooking the ocean. The following wind data was measured nearby, at the Victoria Inner Harbour, at a height of 13 metres above sea level.

Time	Wind Direction	Avg. Wind Speed km/hr
10:00	W	46
11:00	W	52
12:00	W	52
13:00	SW	52
14:00		
15:00	SW	56
16:00	SW	52
17:00	SW	46

Obtaining stable pressure conditions within the building was extremely difficult.

Occupancy:

Most occupants were at home during the test.

The protocol was theoretically feasible, but some practical difficulties arose. The occupants, all of whom are seniors, would not tolerate the elevators being out of operation to any floor. The elevator maintenance company was called. The service man informed us that we could not tape the doors shut because the door motor would burn out if the elevator was sent to the taped floor. He also said that the doors would not open if the depressurization fans were on because the air flow pushes the doors against the guide tracks, causing enough friction to prevent full closure. The building manager allowed us to finish one floor, but asked that we not test the remaining 2.

**.3 Building "B"**

On May 8, 1991 the second blower door test was performed at building "B."

This building contains only 1 elevator, a garbage chute, and gas fireplaces. Two of the test floors (3 and 5) contain electrical cupboards which are poorly sealed from the elevator shaft.

This building contains a laundry room in each suite. The dryer exhaust ducts in these rooms were sealed during testing because dryers had not yet been installed.

Air leakage measurements were taken at various levels of depressurization with the building prepared as described in 4.1.1. To gain insights into the magnitude of air leakage through the shafts, each was unsealed while the building was at its maximum depressurization.

Wind Data:

This test day was very windy as well. Building "B" is also situated to take advantage of ocean view. The most popular wind surfing location in the Victoria area is only a few hundred metres from this building. The following data was recorded nearby at the Gonzales and/or Trial Island weather stations:

Time	Wind Direction	Avg. Wind Speed km/hr
12:00	W	59
16:00	WSW	48
17:00	WSW	35

Obtaining stable pressure conditions within the building was extremely difficult. The stairwell door, through which the fan discharge air was supposed to escape to outdoors, opened directly toward the gusting wind. In an effort to minimize this effect, the air was allowed to exit from the stairwell into an upper floor which had patio doors open on all 4 orientations.

Occupancy:

The building was complete in all respects, but unoccupied.



**.4 Building "C"**

On May 16, 1991 the final blower door test was performed at building "C."

This building contains 2 elevators, and gas fireplaces, but no garbage chute. There was an electrical/telephone cupboard on each floor. The doors were taped, but there were penetrations from the suites into the cupboards which were not addressed. This building also contains a laundry room in each suite. The dryer exhaust ducts in these rooms were sealed during testing because dryers had not yet been installed.

Air leakage measurements were taken at various levels of depressurization with the building prepared as described in 4.1.1. To gain insights into the magnitude of air leakage through the shafts, each was unsealed while the building was at its maximum depressurization.

To determine the magnitude of leakage which occurs through gas fireplaces, all fireplaces were sealed on the 5th floor. These were also unsealed while at maximum depressurization, and the incremental air flow was measured.

Wind Data:

The wind was not significant on this day. The pressure conditions, as dictated by the proportional plus integral controller, were very stable.

The following data was measured in the Victoria Inner Harbour at a height of 13 metres above sea level.

Time	Wind Direction	Avg. Wind Speed km/hr
10:00	SW	5
11:00	SW	9
12:00	SW	11
13:00	SW	11
14:00	SSW	9
15:00	SSW	9
16:00	SSW	9
17:00	SSW	22

**Occupancy:**

The building was complete in all respects, but unoccupied.

---

**4.3 Air Tightness Monitoring Results**

See Appendix "D" for summary graphs and charts.

Appendix "E" contains field printouts of detailed data from the tests in buildings "B" and "C." Hardware problems at building "A" necessitated manual data recording; detailed data is therefore not available. These tables indicate the extent to which the wind can cause fluctuations in the various pressures. Building "B" was tested in high gusting wind conditions; building "C" was tested in light winds.

The results shown in Appendix "D" come from analysis of the tables contained in Appendix "E." Data points were considered acceptable when all 3 pressure differences were close to their setpoints.

The effects of unsealing chutes and turning balance fans off are summarized in the table below. The percentage is calculated as (increased air flow) / (all-sealed air flow at the same pressure difference).

**PERCENT INCREASE IN LEAKAGE DUE TO UNSEALING**

	B4	B5	C5	C6	C7
ELEVATOR	80%	78%	128%	264%	323%
GARBAGE CHT	13%	23%	N/A	N/A	N/A
STAIRS	128%	93%	42%	96%	75%
FIREPLACES	N/A	N/A	2%	N/A	N/A
FLOOR	N/A	N/A	80%	173%	N/A
CEILING	N/A	N/A	N/A	253%	N/A

**4.4 Air Tightness**

For the purposes of comparison, the rates of leakage for various test conditions are shown at a specific building pressure in the following graph.

**COMPARATIVE LEAKAGE AT -40 Pa**

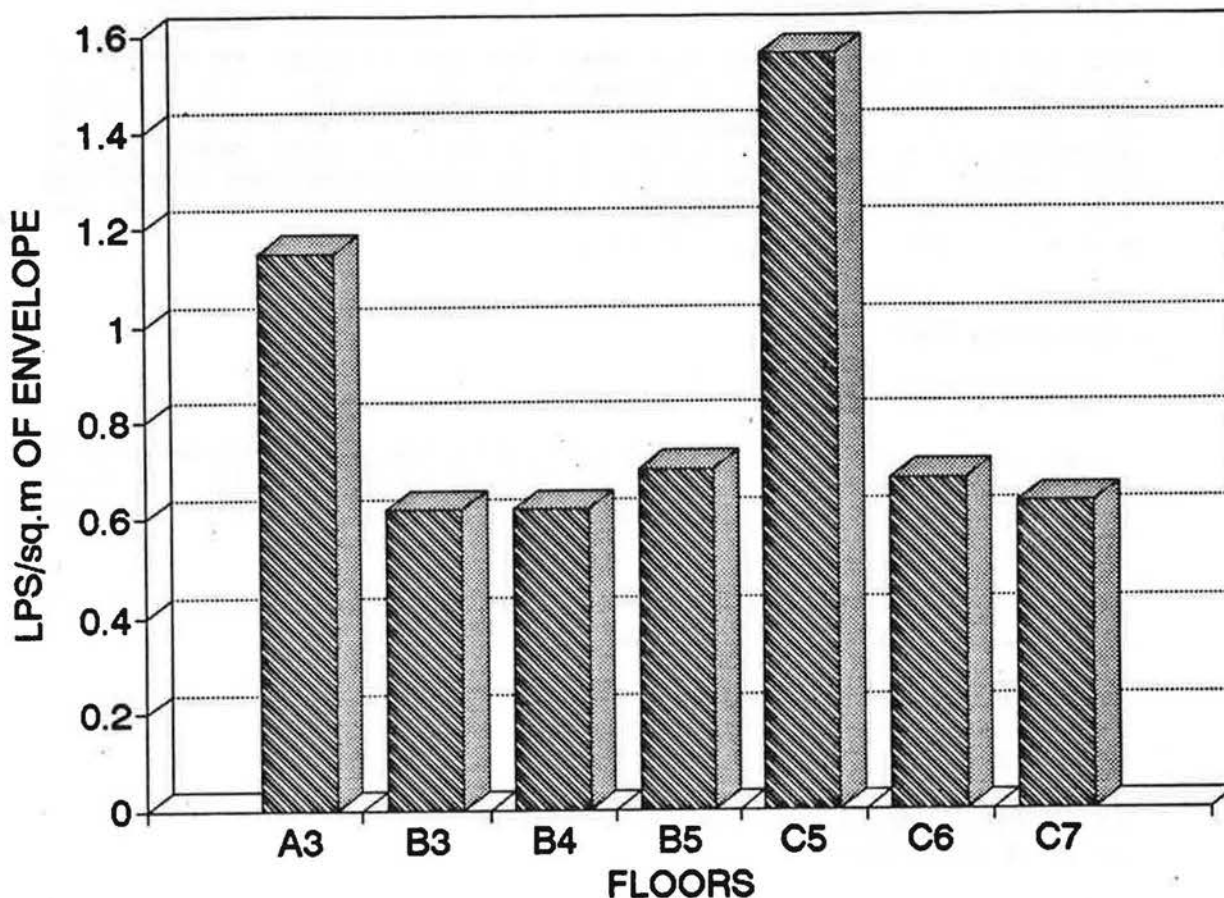

Building "A" is the only building which has been occupied for any length of time. The higher rate of leakage is believed to be largely due to the fouling and sticking of exhaust fan backdraft dampers. Faulty backdraft dampers can have a large impact on results. Assuming that half the 50 Pa depressurization is lost as static pressure drop through a fan, the remaining 25 Pa velocity pressure could result in a 118 lps flow through a 6 inch pipe. Given a total flow of 520 lps in this test, and 16 exhaust fans per floor, the potential effect of open or missing backdraft dampers can be seen.



The results for building "B" are quite uniform despite the wind conditions. Appendix "D" shows an anomaly in the 3rd floor data. This is likely due to wind conditions, or someone other than the test team opening or closing a door or window.

The airflow through the bell mouth was casually monitored before the fans were started and while the sealing procedures were taking place. It is interesting to note that air flowed both in and out of the test floor with as much as 500 lps entering the test floors without mechanical assistance.

The rates of leakage in building "B" are similar to those of building "C" with the exception of floor C5. We did not discover the unusual source of leakage on this floor. It is possible that a seal around an elevator or some other shaft was faulty. The incremental air flow resulting from unsealing the elevator on this floor was less than half that of the other 2 floors in this building.

## .2 Building "A"

### Sources of Air Leakage

A wet finger and a chemically activated smoke pencil were used to identify the major sources of air leakage into the test floor while it was depressurised at -50 Pa relative to outside.

The noticeable sources of air leakage into the central hallway are listed from most to least:

- 1) elevator shaft ( when unsealed)
- 2) stairwell door (when unsealed)
- 3) suite doors
- 4) electrical room
- 5) garbage chute door (when unsealed)
- 6) fire hose cabinet

The noticeable sources of air leakage from outdoors into the suites were as follows:

- 1) bathroom exhaust fans
- 2) kitchen range hoods
- 3) edges of opening windows (closed and latched)
- 4) window to wall junctions (a few places)

Excluding infiltration through the elevator shaft, the greatest source of air leakage was through the bathroom and kitchen exhaust fans. Each of these fans is ducted directly outdoors through separate ducts equipped with backdraft dampers. These dampers were obviously ineffective, since a draft could be easily felt by hand at each fan.

One resident stated that he had found snow on his kitchen range one morning. It had blown in through the exhaust hood, past a backdraft damper, past the fan and onto his frying pan. Several other residents stated that the bathrooms were very cold and drafty when it was windy outside. As none of these bathrooms have outside walls, the cold air must have come in through the exhaust fan.

Inspections of the electrical and plumbing penetrations did not reveal significant infiltration.

### .3 Building "B"

#### Sources of Air Leakage

A wet finger and a chemically activated smoke pencil were used to locate the major sources of air leakage into the test floor while it was depressurised at -50 Pa relative to outside.

The sources of air leakage, listed from most to least, were as follows:

- 1) elevator shaft (when unsealed)
- 2) stairwell door (when unsealed)
- 3) suite doors
- 4) garbage chute door (when unsealed)

Most of the outdoor air entered the suites through

- 1) closed and latched sliding glass patio doors
- 2) edges of opening windows (closed and latched)
- 3) bathroom exhaust fans
- 4) kitchen range hoods
- 5) natural gas fireplace surrounds
- 6) exterior wall electrical outlets

The greatest source of air leakage into the suites was around the sliding glass patio doors. Approximately half of the aluminum frame awning type windows did not seal tightly when latched. Additional latches would rectify this situation. The brand new exhaust fans and range hoods appeared to have much more effective backdraft dampers than those in building "A." The velocity of the incoming air was about half that noticed at building "A."

The gas fireplaces are sealed units, receiving their combustion air directly from outdoors via a co-axial vent and chimney. Very little air entered the suite through the gas fireplaces, but there was noticeable leakage at the junction of the fireplace unit and the wall, and where the gas supply pipe came in through the wall.

A significant draft was noticeable from each of the electrical outlets on the exterior walls.

#### .4 Building "C"

##### Sources of Air Leakage

Major sources of air leakage into the test floor were identified using a wet finger and a chemically activated smoke pencil while the floor was depressurised to -40 Pa relative to outdoors.

The noted sources of air leakage into the central hallway, listed from most to least, were these:

- 1) elevator shaft (when unsealed)
- 2) stairwell door (when unsealed)
- 3) suite doors
- 4) electrical cupboard (when unsealed)

The air which entered the hallway through the suite doors entered the suites by way of the

- 1) sliding glass patio doors
- 2) bathroom exhaust fans
- 3) kitchen range hoods
- 4) edges of opening windows (when closed and latched)
- 5) exterior wall electrical outlets

As was found in building "B," the greatest source of air leakage into the suites was around the sliding glass patio doors, and half of the aluminum frame awning type windows did not seal tightly because they did not have enough latches.

The backdraft dampers installed in the exhaust ducts of the bathroom and kitchen exhaust fans were more effective than those installed at building "A."

A significant draft was noticeable from each of the electrical outlets on the exterior walls.

**.5 Building "D"**

During the walk through inspection of this building, a large area of airborne dirt smudging was noticed on an exterior wall near a doorway opening onto the roof. The manager had recently attempted to seal this doorway with a sheet of polyethylene and masking tape because he had noticed a very strong airflow out of the building around the door. Since the hallway pressurization fan is usually turned off by the residents, the stack effect has induced the large exfiltration made noticeable by the dirt smudging.

#### **4.5 Indoor Air Quality**

##### **.1 Building "A"**

This building's occupants had very few complaints. Some 39% of respondents noted drafty areas within their suites. Drafts could be associated with the ineffective backdraft dampers discovered during the air tests, and may also be related to the window construction.

Less than 30% of respondents reported persistent odours. These are likely due to a combination of wind effect, back-up generator tests, and suite exhaust fans overpowering the hall pressurization fan (HPF).

There is no underground parking at this building.

##### **.2 Building "D"**

This building, although having less occupant satisfaction than building "A," also had few complaints. The problems noted in building "D" are as follows:

- .1 Lack of hall pressurization: The HPF is operated sporadically. Some occupants complain of noise and object to having cold air blown on them while they wait for elevators. Complaints of odours would likely decrease if this situation was rectified.

Installation of medium efficiency filters, new supply registers and balancing dampers is recommended. If the problem persists, installation of a proportional output electric duct heater and duct thermostat is recommended.

- .2 Poor garage ventilation: The 2 garage exhaust fans are not used due to complaints of noise. Stack effect draws auto fumes from the garage into the building. See Appendix "F" for the results of carbon monoxide (CO) monitoring. There is evidence that the floors around the neutral plane of the building are less affected than the main and upper floors. This problem is exacerbated by the lack of hall pressurization.

It is recommended that proper vibration isolators and acoustic lining be applied to the fan systems, and that CO sensors be installed to control the fans.

- .3 Fireplace flue gases entrained in ventilation air: The HPF is located on the roof and is surrounded by fireplace flue outfalls. If the HPF is operated while fireplaces are burning, and the wind is conducive, flue gases are drawn into the make-up air. Extension of the outdoor air intake duct is recommended.

**.3 Building "E"**

This building is the oldest and largest of the 5 buildings dealt with in this project. Based on our questionnaire, it has the lowest occupant satisfaction of the 3 buildings surveyed. The level of satisfaction is significantly higher than what is found in most commercial buildings however. It should be noted that only 12% of the occupants returned the questionnaires. The problems noted are as follows:

- .1 Air infiltration: The windows seal poorly and drafts cause discomfort during cold and windy weather.
- .2 Location of garage exhaust fan discharge: The garage fan discharge is directly below a main floor suite, opening window. Due to the fact that the parking lot is largely open to the outdoors, this is probably not a serious concern.
- .3 Mould: Some 25% of respondents complain of odours. These are believed to be associated with moisture problems (see section 4.5).
- .4 Garbage chute odours: There are complaints of odours, primarily garbage and air freshener smells, from 31% of respondents.

The garbage chute exterior door is often left open to the outdoors. The hatches into the chutes are not tightly sealed. Wind and stack effect draw cold air into the garbage room, up the chute and into the hallways.

It is recommended that an exhaust fan be installed in the garbage room, and that door closers and gaskets be installed on hoppers.



#### **4.6 Moisture Problems**

##### **.1 Building "A"**

Zero percent of respondents reported mould on bathroom tiles, walls or ceilings. Three percent indicated that their windows are often steamed up. Ten percent reported water leakage and damp spots in their suites.

There has been a problem with rain penetration in the corners of certain suites, and, although not yet solved, it is believed to be related to window sealing and/or construction. The windows are appropriate for high-rise, water front application; exterior glazed, awning type. It is common, at this building, to have 2 windows meeting at 90 degrees (corners), and there is a caulked mullion sealing these joints. The likelihood of leakage increases with the use of such connections.

##### **.2 Building "D"**

Zero percent of respondents reported mould on bathroom tiles, walls or ceilings. Eight percent indicated that their windows are often steamed up. Seventy-five percent reported water leakage into their suites and 42% reported damp spots in their suites.

This building is a concrete block structure with sliding windows. After considerable investigation, it was discovered that water was leaking under the flashing at the top of the block walls and into the suites on the four top floors.

The windows' sliding lites are exterior to the fixed lites, which is unusual but superior with respect to leakage. It is suspected that the lip on the track is not high enough to counter wind driven rain.

There are gaps of up to 7 mm between the blocks and the window frames. Most suites have had retrofits to enclose their balconies with glass.

##### **.3 Building "E"**

Six percent of respondents reported mould on bathroom tiles, walls or ceilings. Twenty-five percent indicated that their windows are often steamed up. Thirteen percent reported water leakage into their suites and damp spots in their suites.

The building has a stucco exterior and contains sliding windows.

Rain penetration through walls (cracks in stucco) and windows (around frames and through weatherstripping) are believed to be the primary cause of water leakage.

**5.0 CONCLUSIONS**

**5.1 Air Tightness**

.1 The data from Building "A" is not included in this analysis because extreme wind conditions and manual data collection resulted in poorly correlated data. The data from floor B3 is also not included due to poor results. From the remaining 5 floors' data, it can be said that air leakage is approximately twice the level allowed in R-2000 houses. Floor C5 is the exception to this, at more than 4 times the R-2000 standard.

The discrepancy between the leakage of R-2000 houses and the 4 similar floors is overstated due to the lack of suite exhaust fan sealing. On the other hand, large sources of leakage in houses, such as unusual framing configurations and plumbing penetrations, are greatly reduced in the high-rise tests due to balance floor depressurization.

**NORMALIZED LEAKAGE AREAS**

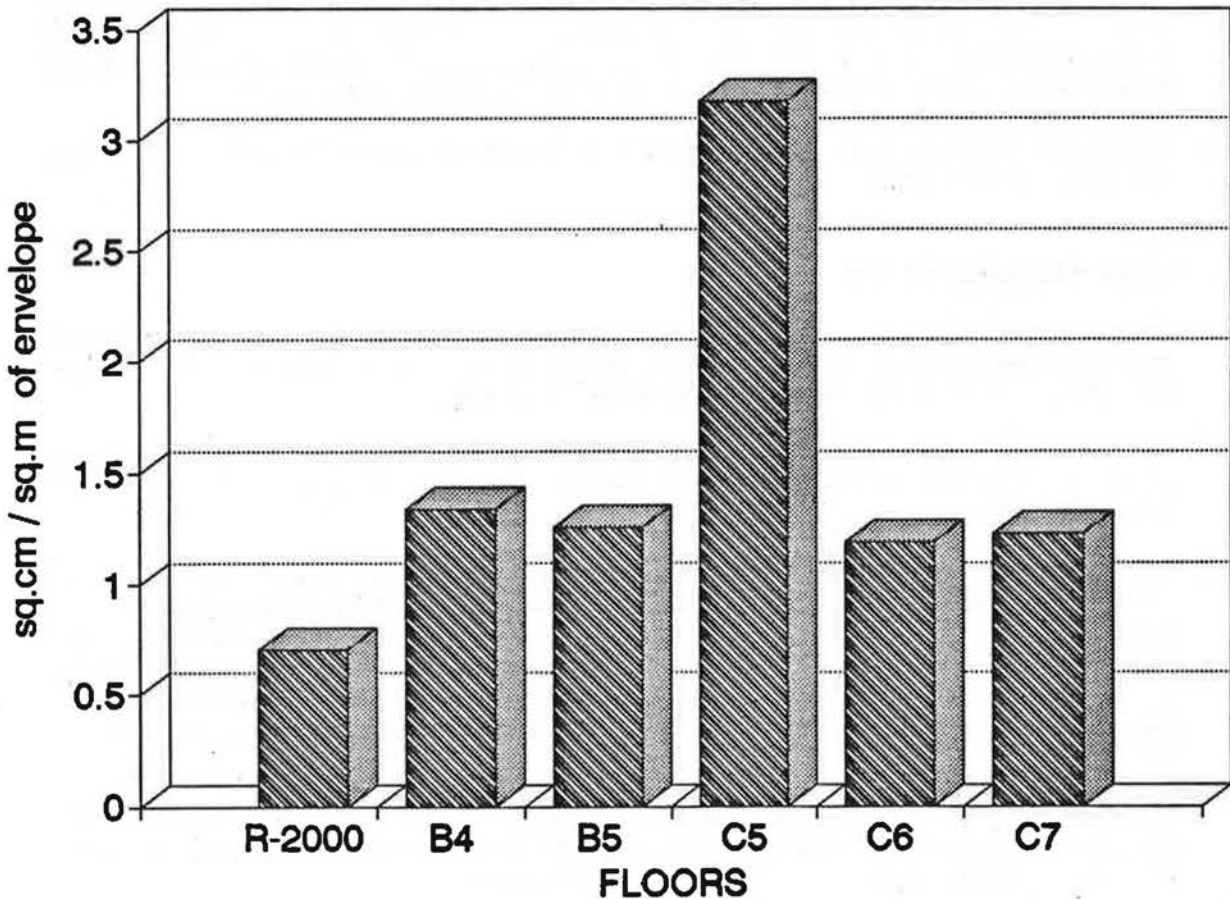



- .2 Most of the air leakage into the suites could be traced to deliberate openings in the building such as elevator shafts, stairwells, garbage chutes, exhaust fans and opening windows. The only other noticeable through-wall air leakage entered the suites through the electrical outlets on the outside walls.
- .3 Unsealing vertical shafts, and turning balance fans off during the leakage tests yielded some interesting results. The elevators were the most significant sources of infiltration, followed by the floors and ceilings, followed by the stairs. Fireplaces were not significant sources of leakage. It would also appear that stack effect makes the leakage from major shafts more pronounced on higher floors.

The reason for the reduction in leakage as a result of opening the garbage chute at building "A" is not certain. The garbage room opens on the leeward side (relative to that day's wind conditions). Given the very strong wind and the fact that the rooftop garbage ventilation system was off, it is very possible that the garbage chute was at a negative pressure.

### 5.2 Indoor Air Quality

- .1 Based upon our experience with occupant questionnaires, the indoor air quality of the buildings studied herein is higher than average commercial buildings, and higher than single family dwellings containing similar ventilation technology.
- .2 Thermal comfort can be compromised by excessive infiltration due to wind and stack effect.

### 5.3 Moisture Problems

- .1 Water penetration from outdoors is common in high-rise apartment buildings. Wind driven rain penetration was reported by the tenants in all of the occupied buildings.
- .2 During the investigation, no problems associated with moisture penetration of walls from the inside of any of the buildings was discovered.
- .3 Although we encountered no evidence of serious condensation, the laws of physics indicate that the use of metal framing, brick ties, and structural members increases the possibility of condensation in walls due to increased thermal bridging. This, combined with the stack effect found in high-rise buildings, makes the possibility of structural and subassembly damage a concern.
- .4 Constant passive ventilation during cold weather helps to maintain suite relative humidity at comfortable levels in the average, west coast, high-rise apartment.

#### **5.4 Mechanical Ventilation**

- .1 Build-up of dirt, lint, grease etc. on suite exhaust fan backdraft dampers can render them ineffective. Exhaust fans with ineffective back flow prevention become significant sources of infiltration.
- .2 Underground parking, garbage disposal and combustion vents present ventilation design challenges which are often overlooked.
- .3 Hall pressurization fan operation has an impact on many IAQ problems in high-rise apartment buildings.

#### **5.5 Overall Ventilation**

- .1 Overall ventilation is generally adequate in most west coast high-rise apartments. The lack of control with respect to volume and location of ventilation can cause comfort problems and structural concerns.

#### **5.6 Air Tightness Test Protocol**

- .1 Testing an occupied building is difficult due to the occupants' requirements for access, security and privacy. The amount of difficulty increases as the number of suites per floor increases. Taping of stairwell doors and elevators restricts occupants' movements. Closing suite windows, installing pressure tubing, and opening partition doors infringes upon their privacy. Leaving suite front doors open creates a security problem, particularly for occupants who are not at home.
- .2 Testing a new, unoccupied building is preferable, but access for tradesmen, realtors and owners can be a problem. Damage to paint, finishes, carpets etc. must be avoided.
- .3 Suite washroom and kitchen exhaust fans were not sealed for these tests. This practice has the following disadvantages:
  - i) the results of the tests reflect leakage through these deliberate penetrations in addition to leakage of the wall assemblies.

- ii) the tests are not directly comparable to the body of testing already performed under the auspices of the R-2000 program.

The advantages of this approach are as follows:

- i) disruption caused within the building is minimized.
- ii) the time required for the test is significantly reduced.
- iii) malfunctioning backdraft dampers can be discovered.

The purpose of future tests must be clarified; are they intended to test wall assemblies, or buildings as a whole?

- .4 When testing elevator shafts, the garage car doors, and the doors between the garage and the elevator vestibule should be closed. Similarly, all stairwell doors should be closed when testing stairwell leakage by the "progressive unsealing" method.
- .5 The outside door to the stairwell of Building "B" was on the windward side of the building. Gusts of wind affected fan stability adversely. This was improved by using an alternate path for air relief: air from the de-pressurization fans discharged into the stairwell and then exited to a floor above which had suite doors open, and patio doors open on all 4 orientations.
- .6 Data logging equipment and automatic fan control are highly recommended for testing which must be done on a pre-arranged day, because high winds make manual data collection very difficult and fan stability poor. Furthermore, if there are significant leaks between floors, even a slight pressure difference can result in significant unwanted air flow.
- .7 Some consideration should be given to adding a requirement for pressure testing of static tubing prior to tests. This will ensure that there are no leaks at fittings.

**APPENDIX "A"**

**PHOTOGRAPHS AND DRAWINGS  
OF STUDIED BUILDINGS**



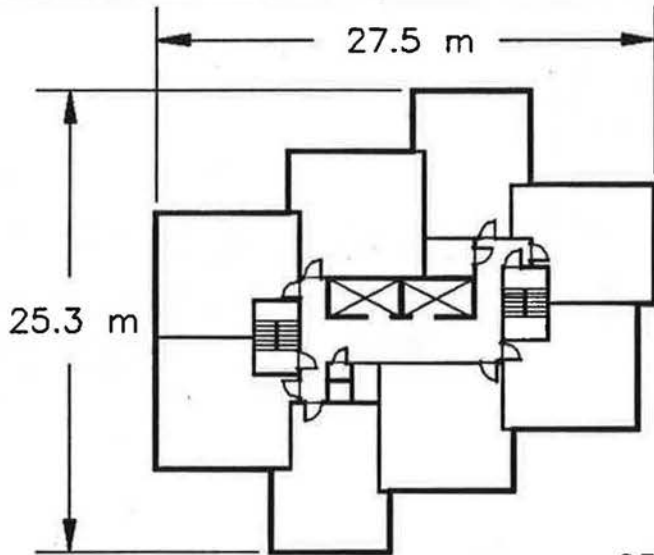

### TYPICAL FLOOR PLAN

FLOOR AREA : 459 sq. m  
 WALL AREA : 273 sq. m  
 8 SUITES PER FLOOR

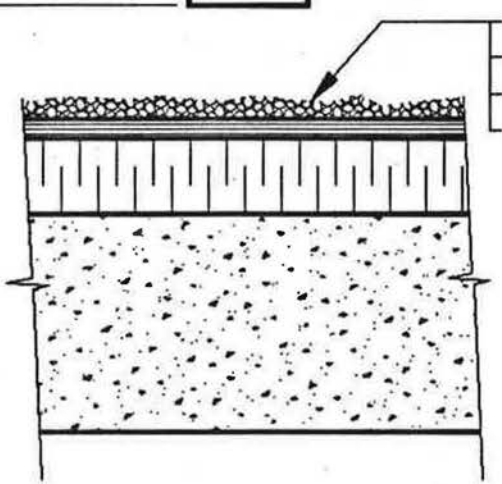

GRAVEL  
 3 PLY MEMBRANE  
 2" EXTRUDED POLYSTYRENE (R10)  
 6" CONCRETE SLAB

### TYPICAL ROOF SECTION

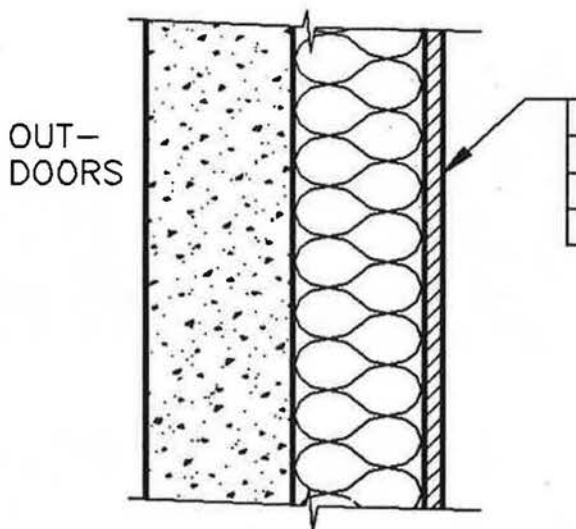

PRE-CAST CONCRETE PANEL  
 3 5/8" STEEL STUDS @ 16" o/c  
 GLASS FIBRE BATTS (R-12)  
 4 mil POLYETHYLENE VAPOR BARRIER  
 1/2" INTERIOR GYPSUM WALLBOARD

### TYPICAL WALL SECTION

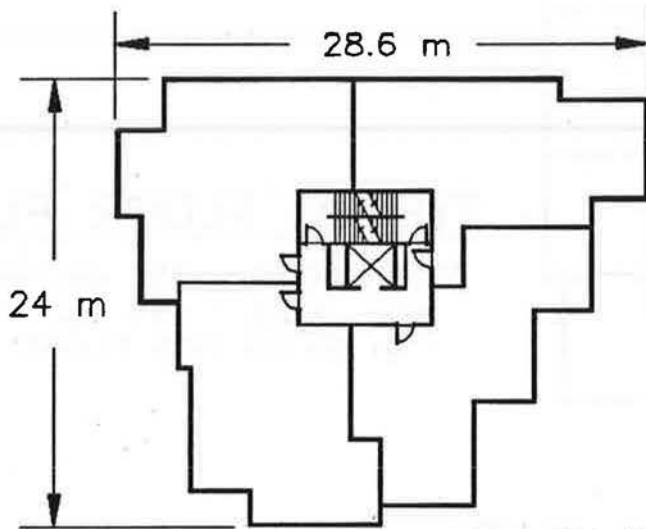

### TYPICAL FLOOR PLAN

FLOOR AREA : 501 sq. m  
 WALL AREA : 305 sq. m  
 4 SUITES PER FLOOR

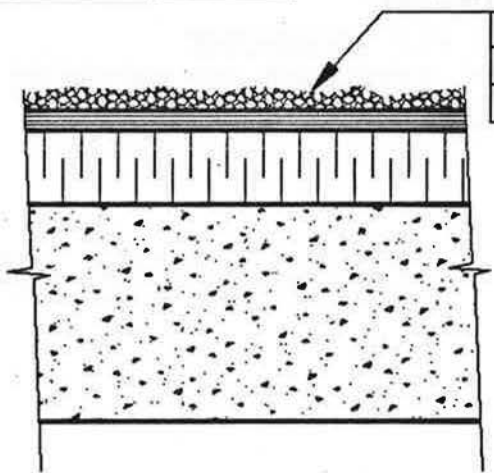

GRAVEL  
 3 PLY MEMBRANE  
 2" EXTRUDED POLYSTYRENE (R10)  
 6" CONCRETE SLAB

### TYPICAL ROOF SECTION

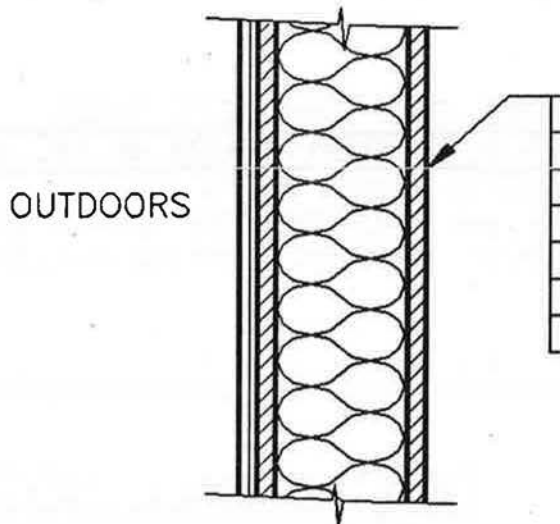

ACRYLIC STUCCO  
 WIRE MESH  
 BUILDING PAPER  
 1/2" EXTERIOR GYPSUM WALLBOARD  
 3 5/8" STEEL STUDS @ 16" o/c  
 GLASS FIBRE BATTS (R-12)  
 4 mil POLYETHYLENE VAPOR BARRIER  
 1/2" INTERIOR GYPSUM WALLBOARD

### TYPICAL WALL SECTION



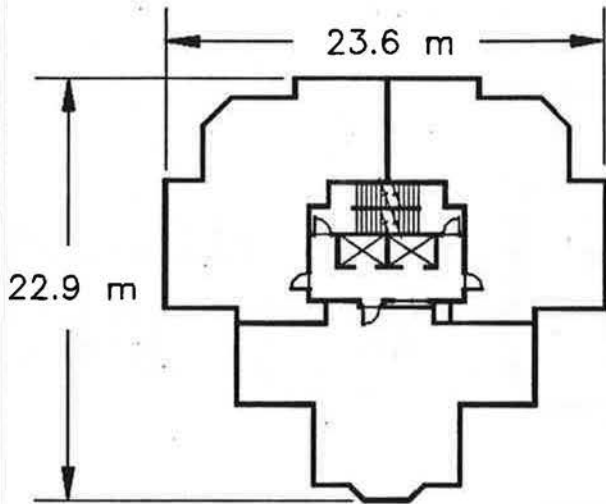

### TYPICAL FLOOR PLAN

FLOOR AREA : 383 sq. m  
 WALL AREA : 242 sq. m  
 3 SUITES PER FLOOR

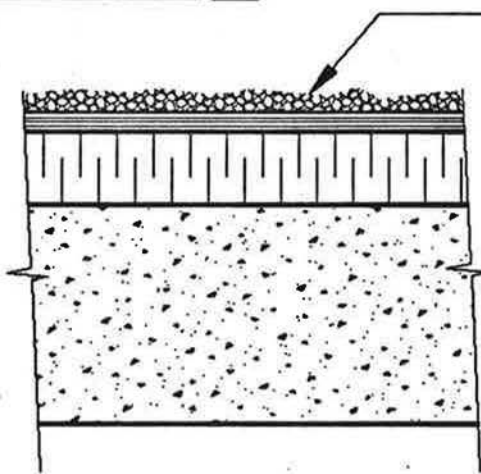

GRAVEL  
 3 PLY MEMBRANE  
 2" EXTRUDED POLYSTYRENE (R10)  
 6" CONCRETE SLAB

### TYPICAL FLAT ROOF SECTION

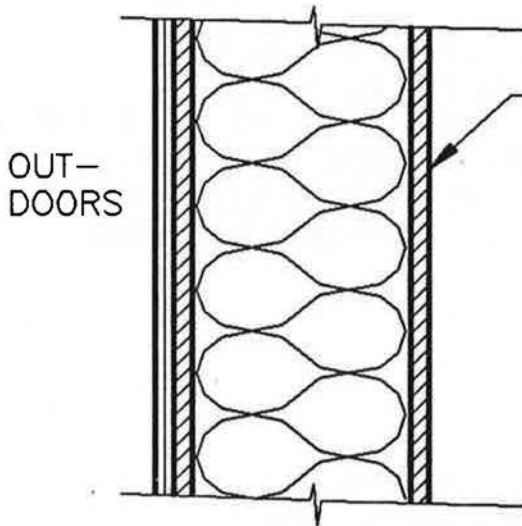

ACRYLIC STUCCO  
 WIRE MESH  
 TYVEK BUILDING FABRIC  
 1/2" EXTERIOR GYPSUM WALLBOARD  
 6" STEEL STUDS @ 16" o/c  
 GLASS FIBRE BATTS (R-19)  
 6 mil POLYETHYLENE VAPOR BARRIER  
 1/2" INTERIOR GYPSUM WALLBOARD

### TYPICAL WALL SECTION

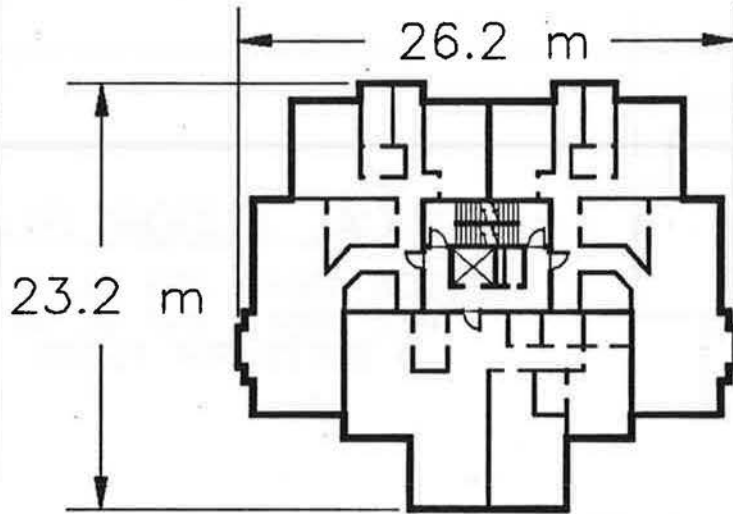

TYPICAL FLOOR PLAN

FLOOR AREA : 470.3 sq. m  
 WALL AREA : 295.8 sq. m  
 3 SUITES PER FLOOR

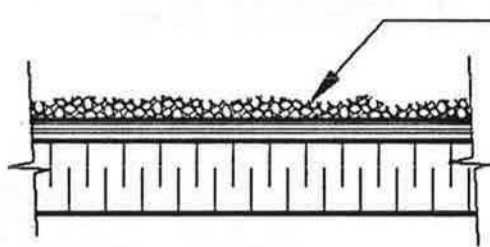

GRAVEL  
 3 PLY MEMBRANE  
 2" EXTRUDED POLYSTYRENE (R10)  
 STEEL ROOF DECK

TYPICAL ROOF SECTION

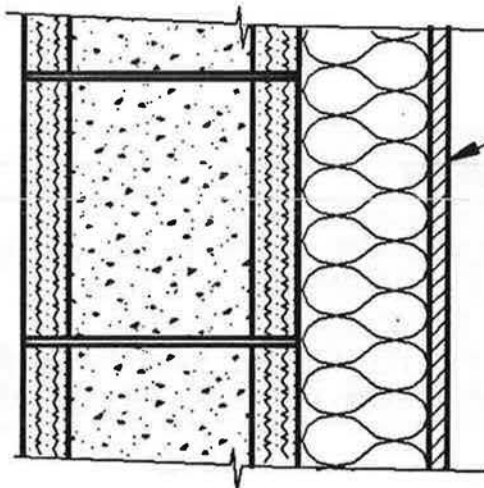

8" CONCRETE BLOCK  
 c/w FILLED CORES  
 3 5/8" STEEL STUDS @ 16" o/c  
 GLASS FIBRE BATTS (R-12)  
 4 mil POLYETHYLENE VAPOR BARRIER  
 1/2" GYPSUM WALLBOARD

TYPICAL WALL SECTION

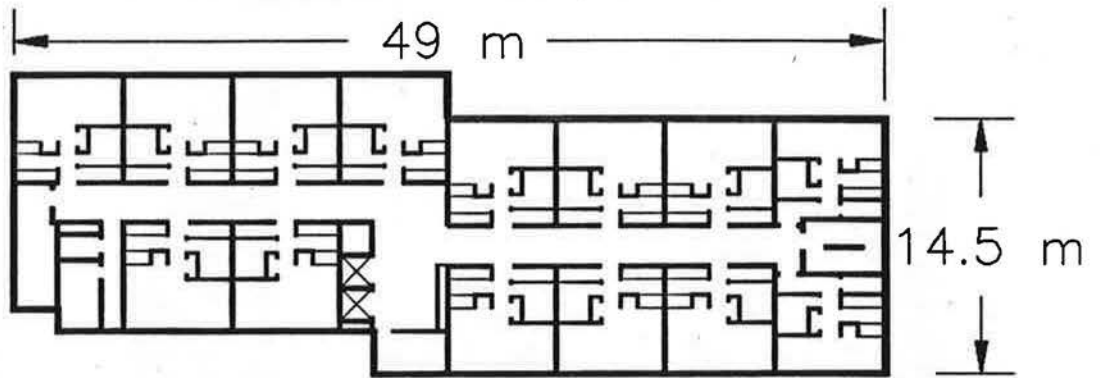

TYPICAL FLOOR PLAN

FLOOR AREA: 785 sq m  
 WALL AREA : 596 sq m  
 14 SUITES PER FLOOR

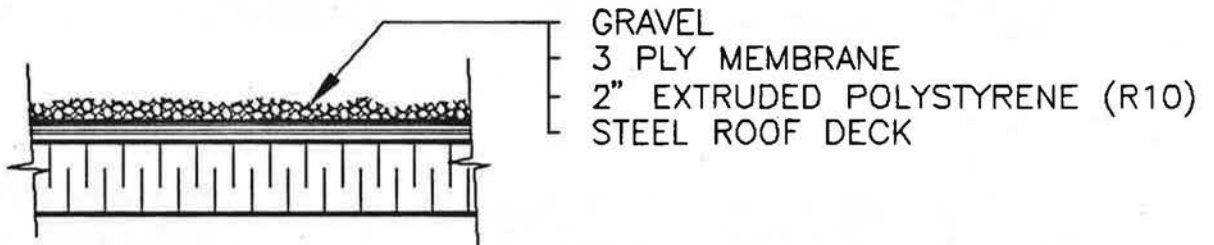

TYPICAL ROOF SECTION

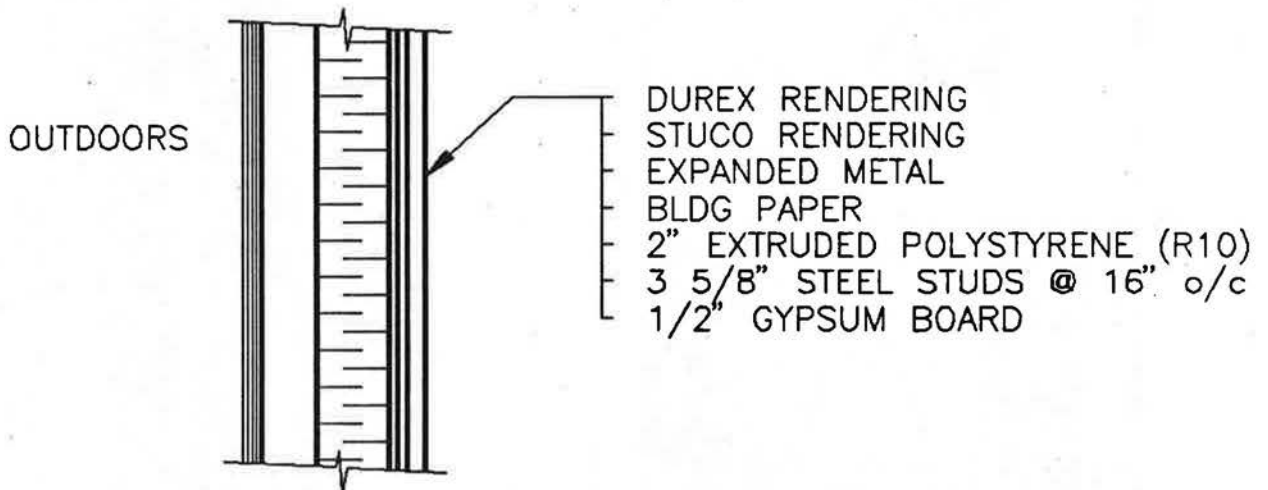

TYPICAL WALL SECTION

PHOTOGRAPHS OF SOME LEAKAGE SOURCES



BLDG 'A' AIR & WATER LEAKAGE



BLDG 'A' ELEVATOR DOOR

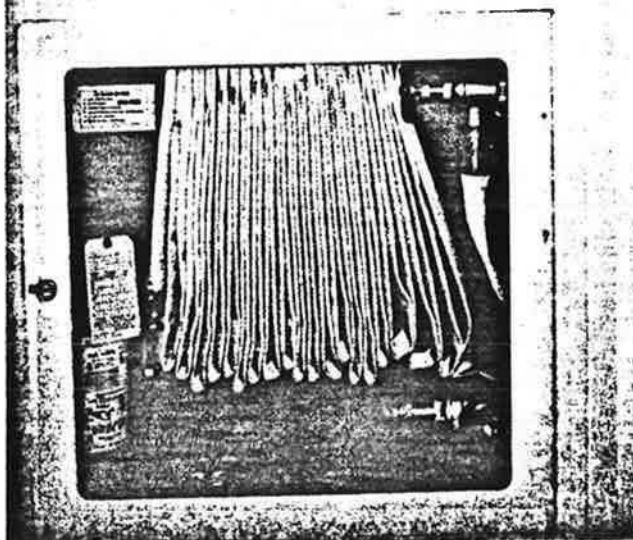
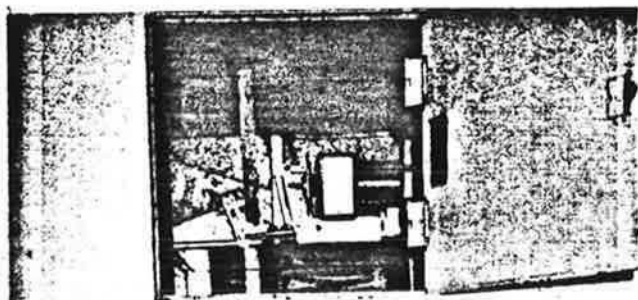

BLDG 'A' FIRE HOSE CAB.

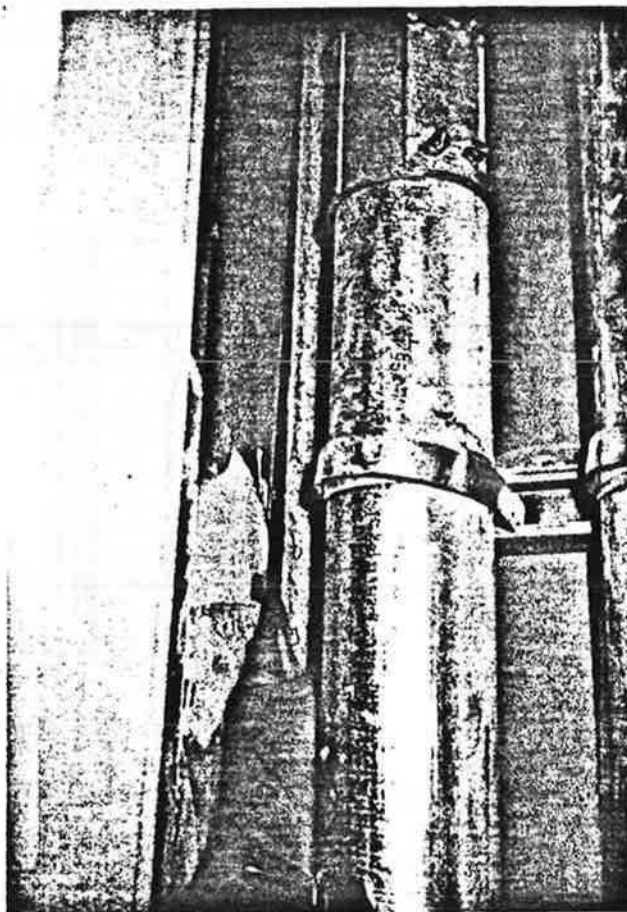

BLDG. 'B' ELECT. RM / ELEVATOR

PHOTOGRAPHS OF SOME LEAKAGE SOURCES

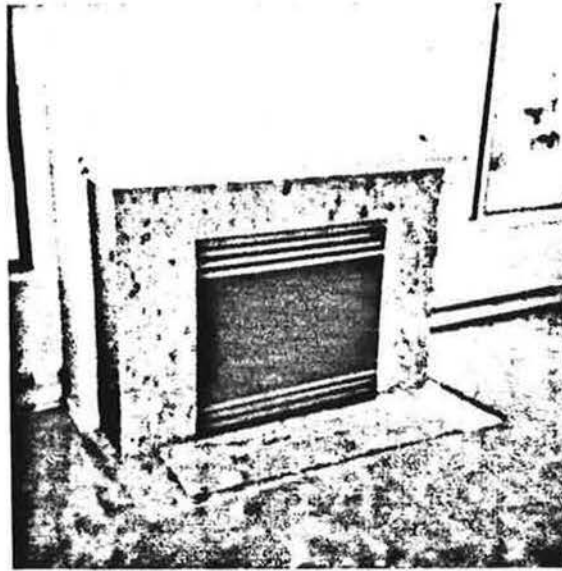

BLDG "B"  
GAS FIREPLACE

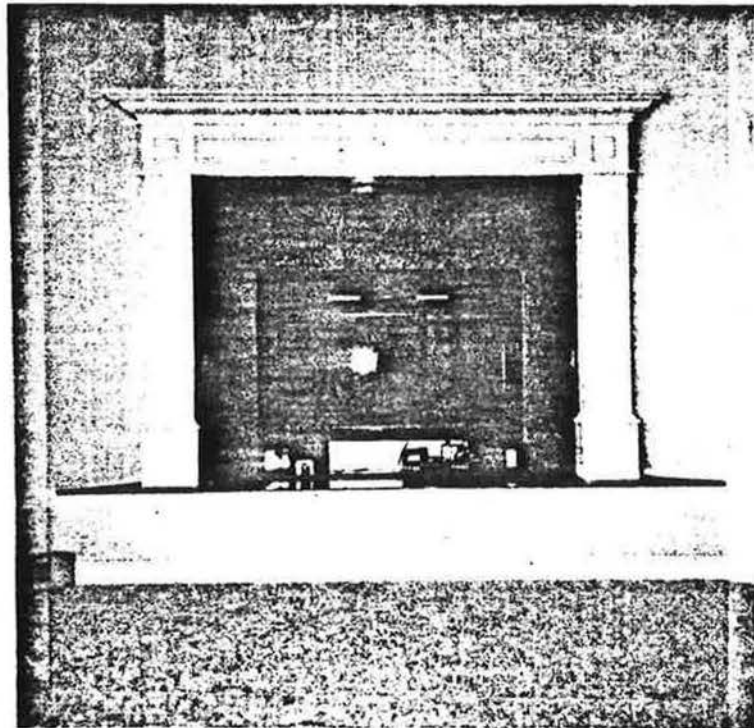

BLDG 'C' - GAS FIREPLACE



**APPENDIX "B"**

**BUILDING CHECKLISTS AND  
OCCUPANT QUESTIONNAIRES**







	YES	NO
Does water leak into your suite?	10%	81%
If "yes", where do you notice it?		
Are there any pets in your suite?	0%	87%
If "yes", what type of pet?		
Are there any drafty areas in your suite?	39%	48%
If "yes", where are they?		
When do you notice them most? '(e.g. "when north wind blows")		

How often does anyone smoke in this suite?	never/ occasionally/ weekly/ daily/ constantly				
	45%	19%	0%	0%	3%
How often is the bathroom fan used?	never/ occasionally/ weekly/ daily/ constantly				
	0%	29%	13%	23%	0%
How often is the kitchen fan used?	never/ occasionally/ weekly/ daily/ constantly				
	0%	39%	0%	23%	0%
How often are the windows open?	never/ occasionally/ weekly/ daily/ constantly				
	0%	6%	0%	35%	23%

	YES	NO
Do you notice any persistent odors in your suite?	29%	58%
Which of the following best describes the odor?		
COOKING	16%	
SMOKING	6%	

	YES	NO
Is there a particular time when you notice this odor?	23%	39%
When? MEALTIMES	23%	

	YES	NO
Do you notice any persistent odors in other areas of your building?	26%	58%
COOKING	19%	
SMOKING	10%	

	YES	NO
Is there a particular time when you notice this odor?	10%	39%
When?		
Where?		



	YES	NO
Does water leak into your suite?	75%	17%
If "yes", where do you notice it?		
Are there any pets in your suite?	0%	92%
If "yes", what type of pet?		
Are there any drafty areas in your suite?	42%	42%
If "yes", where are they?		
When do you notice them most? (e.g. "when north wind blows")		

	never/	occasionally/	weekly/	daily/	constantly
How often does anyone smoke in this suite?	75%	17%			
How often is the bathroom fan used?		33%		8%	50%
How often is the kitchen fan used?	17%	33%		8%	25%
How often are the windows open?		8%			83%

	YES	NO
Do you notice any persistent odors in your suite?	33%	58%
Which of the following best describes the odor?		
COOKING	25%	
FIREPLACE	33%	

	YES	NO
Is there a particular time when you notice this odor?	25%	
When? EVENINGS		

	YES	NO
Do you notice any persistent odors in other areas of your building?	58%	33%
AUTO EXH.	58%	
FIREPLACE	8%	

	YES	NO
Is there a particular time when you notice this odor?	17%	
When?		
Where? FOYER, GARAGE		

**INDOOR AIR QUALITY QUESTIONNAIRE  
BUILDING "E" SUMMARY OF RESPONSES**

**NO SUITES** 138 #RESPONSES 16  
**RETURN RATIO:** 12%

How would you rate your suite by the following comfort indicators?  
Check one box per line. 5 is very good, 3 is tolerable, 1 is bad.

	5	4	3	2	1	
Temperature is constant	31%	19%	38%	0%	0%	Temperature varies
Few drafts	25%	38%	13%	13%	6%	Many drafts
Good ventilation	38%	31%	19%	13%	0%	Poor ventilation
Suite air is fresh	44%	6%	25%	13%	0%	Stale air
Good air movement	50%	6%	25%	13%	0%	Poor air movement
Few odours	56%	13%	25%	0%	0%	Persistent odours
Very little dust	31%	25%	19%	13%	6%	A lot of dust
No mold growth	63%	19%	0%	0%	0%	Mold in several areas

	YES	NO
Are there any damp spots on the walls or ceiling of your suite?	13%	75%
Are the windows often steamed up?	25%	63%
Are any of the carpets, curtains, etc. damp?	13%	75%
Are there any potted plants in this area?	44%	50%
Is there mold on the plants, their pots, or the soil?	0%	81%
Do mites appear to be on the plants?	0%	88%
Are there any air supply vents in your suite?	0%	0%
If "yes", are there dirt, dust, or mold marks around it?	0%	0%
Has carpeting or furniture been installed in the last three months?	19%	75%
Does your suite have a wood burning fireplace?	0%	94%
If "yes", is it used regularly?	0%	0%
Do you use a free standing gas or kerosene heater?	0%	81%
If "yes", is there an odor of combustion fumes in the room?	0%	0%
Does anything in the refrigerator look mouldy?	6%	94%
Is the refrigerator drain blocked?	0%	88%
Is the refrigerator drain pan wet and moldy?	0%	81%
Is there mould on the bathroom tiles, walls, or ceilings?	6%	94%
Is there a humidifier in your suite?	6%	94%
If "yes", is it used regularly?	0%	6%
Is there a dehumidifier in your suite?	0%	94%
If "yes", is it used regularly?	0%	0%
Are there small, steady leaks near a sink, toilet, or tub?	0%	88%

	YES	NO
Does water leak into your suite?	13%	75%
If "yes", where do you notice it?		
Are there any pets in your suite?	6%	81%
If "yes", what type of pet?		
Are there any drafty areas in your suite?	38%	50%
If "yes", where are they?		
When do you notice them most? '(e.g. "when north wind blows")		

How often does anyone smoke in this suite?	never/	occasionally/	weekly/	daily/	constantly
	50%	6%		0%	31% 0%
How often is the bathroom fan used?	never/	occasionally/	weekly/	daily/	constantly
	0%	19%		13%	50% 0%
How often is the kitchen fan used?	never/	occasionally/	weekly/	daily/	constantly
	6%	38%		13%	31% 0%
How often are the windows open?	never/	occasionally/	weekly/	daily/	constantly
	0%	19%		13%	38% 13%

	YES	NO
Do you notice any persistent odors in your suite?	25%	56%
Which of the following best describes the odor?		
MOULDY	19%	
DUSTY	13%	

	YES	NO
Is there a particular time when you notice this odor?	25%	0%
When? MORNINGS	6%	
WHEN COLD	19%	

	YES	NO
Do you notice any persistent odors in other areas of your building?	31%	56%
GARBAGE	13%	
AIR FRESHENE	6%	

	YES	NO
Is there a particular time when you notice this odor?		
When? WEEKENDS	6%	
Where? NEAR GARB. CHT.	6%	



# BUILDING "A"

## I BUILDING COMMON AREAS

1. What year was the building constructed? ~~YES/NO~~
- a) Are the as-built design diagrams for this building missing? ~~YES/NO~~
- b) Are the current design diagrams for this building missing? ~~YES/NO~~
- c) Are the operating and maintenance manuals for the building's HVAC system missing? YES  NO
- d) Is there no routine maintenance program for the HVAC system? YES  NO
2. Have any areas been recarpeted recently? YES  NO
- a) If YES, did odors persist for more than a week after carpet was laid? ~~YES/NO~~
- b) If YES, describe locations:
- \_\_\_\_\_
- \_\_\_\_\_
3. Have any areas been repainted recently? YES  NO
- a) If YES, did odors persist for more than a week after the paint was applied? YES  NO
- b) If YES, describe locations:
- HALLS PAINTED.
- OIL BASED ON CLG; LATEX ON WALLS.
4. Has there been a recent or is there a regular cleaning process which uses large amounts of chemicals or solvents? YES  NO
- a) If YES, what were the chemicals?
- \_\_\_\_\_
5. Is there a fuel-fired central heating unit or DHW system? YES  NO
- a) Is there any physical evidence of leakage of combustion gasses from the furnace into the furnace or flue room or nearby areas? ~~YES/NO~~
- b) Is there the odor of combustion fumes in the room? ~~YES/NO~~
6. Is there an enclosed parking garage? YES  NO
- a) Was the ventilation system found in an inoperative state? ~~YES/NO~~
- b) Is the ventilation system turned off for periods? ~~YES/NO~~
- c) Is the ventilation system controlled? ~~YES/NO~~
- d) Are there carbon monoxide sensors in the garage which control ventilation? ~~YES/NO~~
- e) If so, have they been recently calibrated? ~~YES/NO~~
- f) Are there obstructions in the exhaust or air inlets? ~~YES/NO~~
- g) Are stack forces sucking air from the garage into the building? (check at access doors) ~~YES/NO~~
7. Is there a garbage handling facility? YES  NO
- a) Is the vent system off or ineffective? YES  NO
- GARBAGE VENTED BY HPF.

- b) Is there an air flow pattern from garbage rooms or chutes into the rest of the building? YES  NO
- c) Is there an unusually bad odor or mouldy smell associated with system? YES  NO
8. Is there a pool, hot tub, sauna, or workout room? YES  NO
- a) Does maintenance and cleaning appear to be irregular or inadequate? ~~YES/NO~~
- b) Are there any "mildew" stains on walls, ceilings, floors, fixtures or items such as like shower curtains ~~YES/NO~~
- c) Is there any condensation on walls, floors, windows or ceiling? ~~YES/NO~~
- d) Does humidity appear very high? ~~YES/NO~~
- e) Do any biodegradable products (wood, etc.) get wet regularly? ~~YES/NO~~
9. Are there any basement or sub-basement areas or crawl spaces with dirt floors? YES  NO
- a) Are there occupied areas nearby?  
If YES, describe locations:  
\_\_\_\_\_  
\_\_\_\_\_
- b) Do these spaces lack ventilation? ~~YES/NO~~  
Are there musty odors in these areas or nearby? ~~YES/NO~~
10. Are there rooms with sizeable holes in the walls or floor, such as sump pits, gas and water entrances, cracks, etc.? YES  NO
- a) If YES, describe location(s):  
SUMP PUMP - BSMT. PUMP RM.
- b) Do these spaces lack ventilation? YES  NO
- c) Are there musty odors in these areas or nearby? YES  NO
11. Is there foam insulation in the walls of the building? YES  NO
- a) The type of insulation is polyurethane / polystyrene / urea formaldehyde / unknown.
12. Do drawings show asbestos insulation for pipes, fire protection of structure, etc.? YES  NO
- a) If YES, does inspection reveal loose fibre especially near air handling equipment and ducts? ~~YES/NO~~
13. Has there ever been a "water crisis" such as a flood or overflow? YES  NO
14. Are there any signs of moisture problems such as:  
a) stains or dampness on walls, floors or ceilings? YES  NO  
b) stained, streaked, or damp carpets? YES  NO  
c) mouldy odors, or musty smells? YES  NO  
WINDOW LEAKAGE.

## II MECHANICAL SYSTEMS AND HVAC OPERATION

If the building contains two or more towers or wings, each controlled by a different HVAC system, a copy of this sheet should be filled out for each.

15. Describe ventilation system:

HALL PRESSURIZATION FAN (HPF).  
SMOKE CONTROL FAN IN STAIRWELLS (ON IF FIRE).  
KITCHEN & W/R EXHAUST FANS PER SUITE.

16. Is the amount of fresh air used by the ventilation system the same all year round? HPF  YES  NO
17. Is the ventilation system of the recirculating type?  YES  NO
- a) Does the HVAC system use an economizer cycle?  YES  NO
- b) What is the maximum percentage of fresh air used? 100 %
- c) What is the minimum percentage of fresh air used? 100 %
- d) What is the fresh air percentage just now? 100 %
18. Air supplied to the floors by: constant volume systems / variable air volume (VAV) system / heat pumps / other / unknown? OFF DURING GENERATOR TESTS TWICE/m.
19. Is there a corridor pressurization system?  YES  NO
- a) Is the "corridor-to-apartment" flow reversed?  YES  NO
20. At what temperature is the tank supplying hot water to the building maintained? 60°C
21. Are there distinct fresh-air intakes for the building HVAC system?  YES  NO
- a) Are there intakes below third floor level and above a busy street?  YES  NO
- b) Are there intakes within 10 metres (30 feet) of the entrance or exit to a parking garage?  YES  NO
- c) Are there intakes within 10 metres (30 feet) of the exhausts of this or an adjacent building?  YES  NO
- d) Are intakes near standing water or a cooling tower?  YES  NO
- e) Is there a build up of organic debris near the intakes?  YES  NO
- f) Are there any other sources of pollution near any of the intakes?  YES  NO
22. Does this building have a particulate (dust) filter system installed in the fresh air intake?  YES  NO
- a) Are the filters missing?  YES  NO
- b) Are the filters changed less frequently than recommended by the manufacturer?  YES  NO
- c) Do the filters fit so poorly that air bypasses them at the edges?  YES  NO
- d) Are the filters matted or dirty?  YES  NO
- e) Are the filters wet?  YES  NO
- HPF : HORSE HAIR PRE-FILT; MED. EFF MAIN FILT.

23. Are spray humidifiers used in this building? YES  NO
- a) Are the spray humidifiers supposed to operate at this time of year? ~~YES~~ ~~NO~~
- b) Are the spray humidifiers operating now? ~~YES~~ ~~NO~~
- If YES, answer the questions below:
- c) Are the spray humidifier pans plugged so that they are not draining properly? ~~YES~~ ~~NO~~
- d) Is there slime in the humidifier pans? ~~YES~~ ~~NO~~
- e) Are there mouldy odors? ~~YES~~ ~~NO~~
- f) Is there mould in the ducts near the humidifiers? ~~YES~~ ~~NO~~
- g) Is there evidence of foaming in the humidifiers? ~~YES~~ ~~NO~~
- h) Is the water hard in this region? ~~YES~~ ~~NO~~
- i) If so, are there hard water deposits on the vanes? ~~YES~~ ~~NO~~
- j) Are the hard water deposits removed by scraping the vanes and blowing the dust into the ducts? ~~YES~~ ~~NO~~
24. Are steam humidifiers used in this building? ~~YES~~ ~~NO~~
- a) Are the steam humidifiers supposed to operate at this time of year? ~~YES~~ ~~NO~~
- b) Are the steam humidifiers operating now? ~~YES~~ ~~NO~~
- If YES, answer the questions below:
- c) Are chemicals used in the boiler or the pipes to protect against corrosion? ~~YES~~ ~~NO~~
- If YES, state names of chemicals:
- \_\_\_\_\_
- \_\_\_\_\_
- \_\_\_\_\_
25. Does this building have an air-chilling system? ~~YES~~ ~~NO~~
- a) Is the chilling system supposed to operate at this time of year? ~~YES~~ ~~NO~~
- b) Is the chilling system operating now? ~~YES~~ ~~NO~~
- If YES, answer the questions below:
- c) Are the condensate trays cleaned less often than once a week? ~~YES~~ ~~NO~~
- d) Is there slime or growth in the condensate trays? ~~YES~~ ~~NO~~
- e) Is there dirt on the cooling coils? ~~YES~~ ~~NO~~
- f) Are there mouldy odors in the system? ~~YES~~ ~~NO~~
26. Are the ventilation ducts or plenums insulated? YES  NO
- a) Is the insulation on the inside and directly exposed to the moving air? ~~YES~~ ~~NO~~
- b) Is it more than five years since the ducts or plenums were last cleaned? ~~YES~~ ~~NO~~
27. Are there any signs of condensation in ducts? (Check cold spots such as near inlets and after cooling coils first.) YES  NO

# BUILDING "D"

## I BUILDING COMMON AREAS

- 1. What year was the building constructed? 1981
  - a) Are the as-built design diagrams for this building missing?  YES  NO
  - b) Are the current design diagrams for this building missing?  YES  NO
  - c) Are the operating and maintenance manuals for the building's HVAC system missing?  YES  NO
  - d) Is there no routine maintenance program for the HVAC system?  YES  NO
  
- 2. Have any areas been recarpeted recently? YES  NO
  - a) If YES, did odors persist for more than a week after carpet was laid? ~~YES  NO~~
  - b) If YES, describe locations:  

---



---
  
- 3. Have any areas been repainted recently?  YES  NO
  - a) If YES, did odors persist for more than a week after the paint was applied?  YES  NO
  - b) If YES, describe locations:  
1ST FLOOR SUITES & HALL. OIL BASED.  
SMELL NOTICED UP TO 4TH FLOOR
  
- 4. Has there been a recent or is there a regular cleaning process which uses large amounts of chemicals or solvents? YES  NO
  - a) If YES, what were the chemicals?  

---
  
- 5. Is there a fuel-fired central heating unit or DHW system? YES  NO
  - a) Is there any physical evidence of leakage of combustion gasses from the furnace into the furnace or flue room or nearby areas? ~~YES  NO~~
  - b) Is there the odor of combustion fumes in the room? ~~YES  NO~~
  
- 6. Is there an enclosed parking garage?  YES  NO
  - a) Was the ventilation system found in an inoperative state?  YES  NO
  - b) Is the ventilation system turned off for periods?  YES  NO
  - c) Is the ventilation system controlled?  YES  NO
  - d) Are there carbon monoxide sensors in the garage which control ventilation? YES  NO
  - e) If so, have they been recently calibrated? ~~YES  NO~~
  - f) Are there obstructions in the exhaust or air inlets? YES  NO
  - g) Are stack forces sucking air from the garage into the building? (check at access doors)  YES  NO
  
- 7. Is there a garbage handling facility?  YES  NO
  - a) Is the vent system off or ineffective? YES  NO

THE GARBAGE CHUTE HAS BEEN SEALED.  
OCCUPANTS CARRY GARBAGE TO BIN.



- b) Is there an air flow pattern from garbage rooms or chutes into the rest of the building? YES  NO
- c) Is there an unusually bad odor or mouldy smell associated with system? YES  NO
- 8. Is there a pool, hot tub, sauna, or workout room? YES  NO
  - a) Does maintenance and cleaning appear to be irregular or inadequate? ~~YES/NO~~
  - b) Are there any "mildew" stains on walls, ceilings, floors, fixtures or items such as like shower curtains ~~YES/NO~~
  - c) Is there any condensation on walls, floors, windows or ceiling? ~~YES/NO~~
  - d) Does humidity appear very high? ~~YES/NO~~
  - e) Do any biodegradable products (wood, etc.) get wet regularly? ~~YES/NO~~
- 9. Are there any basement or sub-basement areas or crawl spaces with dirt floors? YES  NO
  - a) Are there occupied areas nearby?  
If YES, describe locations:  
\_\_\_\_\_  
\_\_\_\_\_
  - b) Do these spaces lack ventilation? ~~YES/NO~~  
Are there musty odors in these areas or nearby? ~~YES/NO~~
- 10. Are there rooms with sizeable holes in the walls or floor, such as sump pits, gas and water entrances, cracks, etc.? YES  NO
  - a) If YES, describe location(s):  
\_\_\_\_\_  
\_\_\_\_\_
  - b) Do these spaces lack ventilation? ~~YES/NO~~
  - c) Are there musty odors in these areas or nearby? ~~YES/NO~~
- 11. Is there foam insulation in the walls of the building? YES  NO
  - a) The type of insulation is polyurethane / polystyrene / urea formaldehyde / unknown.
- 12. Do drawings show asbestos insulation for pipes, fire protection of structure, etc.? YES  NO
  - a) If YES, does inspection reveal loose fibre especially near air handling equipment and ducts? ~~YES/NO~~
- 13. Has there ever been a "water crisis" such as a flood or overflow? YES  NO
- 14. Are there any signs of moisture problems such as:
  - a) stains or dampness on walls, floors or ceilings? YES  NO
  - b) stained, streaked, or damp carpets? YES  NO
  - c) mouldy odors, or musty smells? YES  NO

II MECHANICAL SYSTEMS AND HVAC OPERATION

If the building contains two or more towers or wings, each controlled by a different HVAC system, a copy of this sheet should be filled out for each.

15. Describe ventilation system:

2 GARAGE EXHAUST FANS.  
HALL PRES. FAN (HPF) ON ROOF.  
KITCH + W/B EXHAUST FANS / SUITE.

16. Is the amount of fresh air used by the ventilation system the same all year round? HPF OFF OCT. - MAR.

YES  NO

17. Is the ventilation system of the recirculating type?

YES  NO

a) Does the HVAC system use an economizer cycle?

~~YES/NO~~

b) What is the maximum percentage of fresh air used?

100 %

c) What is the minimum percentage of fresh air used?

100 %

d) What is the fresh air percentage just now?

0 %

18. Air supplied to the floors by:  
 constant volume systems / variable air volume (VAV) system /  
 heat pumps / other / unknown?

19. Is there a corridor pressurization system?

YES  NO

a) Is the "corridor-to-apartment" flow reversed?

YES  NO

20. At what temperature is the tank supplying hot water to the building maintained? SHORTAGE OF HOT WATER NECESSITATES 7°C

21. Are there distinct fresh-air intakes for the building HVAC system?

YES  NO

a) Are there intakes below third floor level and above a busy street?

YES  NO ~~STE~~

b) Are there intakes within 10 metres (30 feet) of the entrance or exit to a parking garage?

YES  NO

c) Are there intakes within 10 metres (30 feet) of the exhausts of this or an adjacent building?

YES  NO ~~STE~~

d) Are intakes near standing water or a cooling tower?

~~YES/NO~~

e) Is there a build up of organic debris near the intakes?

~~YES/NO~~

f) Are there any other sources of pollution near any of the intakes?

YES  NO

FIREPLACE CHIMNEYS SURROUND HPF. SMOKE SMELLS THROUGHOUT

22. Does this building have a particulate (dust) filter system installed in the fresh air intake? HPF

YES  NO

a) Are the filters missing?

YES  NO

b) Are the filters changed less frequently than recommended by the manufacturer?

YES  NO

c) Do the filters fit so poorly that air bypasses them at the edges? ~

YES  NO

d) Are the filters matted or dirty?

YES  NO

e) Are the filters wet?

YES  NO



23. Are spray humidifiers used in this building? YES  NO  STE
- a) Are the spray humidifiers supposed to operate at this time of year? ~~YES/NO~~
- b) Are the spray humidifiers operating now? ~~YES/NO~~
- If YES, answer the questions below:
- c) Are the spray humidifier pans plugged so that they are not draining properly? ~~YES/NO~~
- d) Is there slime in the humidifier pans? ~~YES/NO~~
- e) Are there mouldy odors? ~~YES/NO~~
- f) Is there mould in the ducts near the humidifiers? ~~YES/NO~~
- g) Is there evidence of foaming in the humidifiers? ~~YES/NO~~
- h) Is the water hard in this region? ~~YES/NO~~
- i) If so, are there hard water deposits on the vanes? ~~YES/NO~~
- j) Are the hard water deposits removed by scraping the vanes and blowing the dust into the ducts? ~~YES/NO~~
24. Are steam humidifiers used in this building? YES  NO
- a) Are the steam humidifiers supposed to operate at this time of year? ~~YES/NO~~
- b) Are the steam humidifiers operating now? ~~YES/NO~~
- If YES, answer the questions below:
- c) Are chemicals used in the boiler or the pipes to protect against corrosion? ~~YES/NO~~
- If YES, state names of chemicals:
- \_\_\_\_\_
- \_\_\_\_\_
- \_\_\_\_\_
25. Does this building have an air-chilling system? YES  NO
- a) Is the chilling system supposed to operate at this time of year? ~~YES/NO~~
- b) Is the chilling system operating now? ~~YES/NO~~
- If YES, answer the questions below:
- c) Are the condensate trays cleaned less often than once a week? ~~YES/NO~~
- d) Is there slime or growth in the condensate trays? ~~YES/NO~~
- e) Is there dirt on the cooling coils? ~~YES/NO~~
- f) Are there mouldy odors in the system? ~~YES/NO~~
26. Are the ventilation ducts or plenums insulated? YES  NO
- a) Is the insulation on the inside and directly exposed to the moving air? ~~YES/NO~~
- b) Is it more than five years since the ducts or plenums were last cleaned? ~~YES/NO~~
27. Are there any signs of condensation in ducts? (Check cold spots such as near inlets and after cooling coils first.) YES  NO

BUILDING "E"  
I BUILDING COMMON AREAS

- 1. What year was the building constructed? 1976
  - a) Are the as-built design diagrams for this building missing? YES  NO
  - b) Are the current design diagrams for this building missing? ~~YES~~  NO
  - c) Are the operating and maintenance manuals for the building's HVAC system missing? YES  NO
  - d) Is there no routine maintenance program for the HVAC system? YES  NO   
1/mo
  
- 2. Have any areas been recarpeted recently? YES  NO 
  - a) If YES, did odors persist for more than a week after carpet was laid? YES  NO   
LOWER HALLS
  - b) If YES, describe locations:  
\_\_\_\_\_  
\_\_\_\_\_
  
- 3. Have any areas been repainted recently? YES  NO 
  - a) If YES, did odors persist for more than a week after the paint was applied? YES  NO   
LATEX PAINTS
  - b) If YES, describe locations:  
\_\_\_\_\_  
\_\_\_\_\_
  
- 4. Has there been a recent or is there a regular cleaning process which uses large amounts of chemicals or solvents? YES  NO 
  - a) If YES, what were the chemicals?  
GARBAGE RM + CHUTE: PINE OIL + DEGREASER 1/mo
  
- 5. Is there a fuel-fired central heating unit or DHW system? YES  NO 
  - a) Is there any physical evidence of leakage of combustion gasses from the furnace into the furnace or flue room or nearby areas? YES  NO
  - b) Is there the odor of combustion fumes in the room? YES  NO
  
- 6. Is there an enclosed parking garage? YES  NO 
  - a) Was the ventilation system found in an inoperative state? YES  NO
  - b) Is the ventilation system turned off for periods? YES  NO
  - c) Is the ventilation system controlled? YES  NO
  - d) Are there carbon monoxide sensors in the garage which control ventilation? YES  NO
  - e) If so, have they been recently calibrated? YES  NO
  - f) Are there obstructions in the exhaust or air inlets? YES  NO
  - g) Are stack forces sucking air from the garage into the building? (check at access doors) YES  NO
  
- 7. Is there a garbage handling facility? YES  NO 
  - a) Is the vent system off or ineffective? YES  NO   
PASSIVE VENT AT TOP OF CHUTE.

- b) Is there an air flow pattern from garbage rooms or chutes into the rest of the building? WHEN EXT. GARB. RM. DOOR OPEN YES  NO
- c) Is there an unusually bad odor or mouldy smell associated with system? YES  NO
8. Is there a pool, hot tub, sauna, or workout room? YES  NO
- a) Does maintenance and cleaning appear to be irregular or inadequate? YES  NO
- b) Are there any "mildew" stains on walls, ceilings, floors, fixtures or items such as like shower curtains SOME X/R TILES. YES  NO
- c) Is there any condensation on walls, floors, windows or ceiling? YES  NO LAUNDRY
- d) Does humidity appear very high? YES  NO
- e) Do any biodegradable products (wood, etc.) get wet regularly? YES  NO
9. Are there any basement or sub-basement areas or crawl spaces with dirt floors? YES  NO
- a) Are there occupied areas nearby?  
If YES, describe locations:  
\_\_\_\_\_  
\_\_\_\_\_
- b) Do these spaces lack ventilation? ~~YES~~  ~~NO~~  
Are there musty odors in these areas or nearby? ~~YES~~  ~~NO~~
10. Are there rooms with sizeable holes in the walls or floor, such as sump pits, gas and water entrances, cracks, etc.? YES  NO
- a) If YES, describe location(s):  
SUMP IN GARAGE (OPEN GARAGE).  
\_\_\_\_\_
- b) Do these spaces lack ventilation? YES  NO
- c) Are there musty odors in these areas or nearby? YES  NO
11. Is there foam insulation in the walls of the building? YES  NO
- a) The type of insulation is polyurethane / polystyrene / urea formaldehyde / unknown.
12. Do drawings show asbestos insulation for pipes, fire protection of structure, etc.? ~~YES~~  ~~NO~~
- a) If YES, does inspection reveal loose fibre especially near air handling equipment and ducts? ~~YES~~  ~~NO~~
13. Has there ever been a "water crisis" such as a flood or overflow? YES  NO  
LAUNDRY RM. WASHING MACHINE OVERFLOW.
14. Are there any signs of moisture problems such as:  
a) stains or dampness on walls, floors or ceilings? 10TH FLOOR YES  NO
- b) stained, streaked, or damp carpets? YES  NO
- c) mouldy odors, or musty smells? YES  NO

## II MECHANICAL SYSTEMS AND HVAC OPERATION

If the building contains two or more towers or wings, each controlled by a different HVAC system, a copy of this sheet should be filled out for each.

15. Describe ventilation system:

2 HALL PRES. FANS: LOW SPEED WINTER; HI SUMMER.  
2 GARAGE EXHAUST FANS.  
KITCH & W/R EXHAUST FANS PER SUITE.  
2 FIRE EXIT PRES. FANS. 1 COMBUSTION AIR FAN.

16. Is the amount of fresh air used by the ventilation system the same all year round?

YES  NO

17. Is the ventilation system of the recirculating type?

YES  NO

a) Does the HVAC system use an economizer cycle?

YES  NO

b) What is the maximum percentage of fresh air used?

HPF 100 %

c) What is the minimum percentage of fresh air used?

100 %

d) What is the fresh air percentage just now?

100 %

18. Air supplied to the floors by:

constant volume systems / variable air volume (VAV) system / heat pumps / other / unknown?

19. Is there a corridor pressurization system?

YES  NO

a) Is the "corridor-to-apartment" flow reversed?

YES  NO

20. At what temperature is the tank supplying hot water to the building maintained?

6 OIL-FIRED TANKS - 2 GPH OIL @ 55°C

21. Are there distinct fresh-air intakes for the building HVAC system? HPF

YES  NO

a) Are there intakes below third floor level and above a busy street? HPF

YES  NO

b) Are there intakes within 10 metres (30 feet) of the entrance or exit to a parking garage?

YES  NO

c) Are there intakes within 10 metres (30 feet) of the exhausts of this or an adjacent building?

YES  NO

d) Are intakes near standing water or a cooling tower?

YES  NO

e) Is there a build up of organic debris near the intakes?

YES  NO

f) Are there any other sources of pollution near any of the intakes?

YES  NO

DHW FLUE NEAR HPF; GARAGE E/F DISCH. DIRECTLY BLW. WINDOWS.

22. Does this building have a particulate (dust) filter system installed in the fresh air intake?

6% EFF. ON HPF,

YES  NO

a) Are the filters missing?

YES  NO

b) Are the filters changed less frequently than recommended by the manufacturer?

YES  NO

c) Do the filters fit so poorly that air bypasses them at the edges?

YES  NO

d) Are the filters matted or dirty?

YES  NO

e) Are the filters wet?

YES  NO

23. Are spray humidifiers used in this building? YES  NO
- a) Are the spray humidifiers supposed to operate at this time of year? ~~YES~~ ~~NO~~
- b) Are the spray humidifiers operating now? ~~YES~~ ~~NO~~
- If YES, answer the questions below:
- c) Are the spray humidifier pans plugged so that they are not draining properly? ~~YES~~ ~~NO~~
- d) Is there slime in the humidifier pans? ~~YES~~ ~~NO~~
- e) Are there mouldy odors? ~~YES~~ ~~NO~~
- f) Is there mould in the ducts near the humidifiers? ~~YES~~ ~~NO~~
- g) Is there evidence of foaming in the humidifiers? ~~YES~~ ~~NO~~
- h) Is the water hard in this region? ~~YES~~ ~~NO~~
- i) If so, are there hard water deposits on the vanes? ~~YES~~ ~~NO~~
- j) Are the hard water deposits removed by scraping the vanes and blowing the dust into the ducts? ~~YES~~ ~~NO~~
24. Are steam humidifiers used in this building? YES  NO
- a) Are the steam humidifiers supposed to operate at this time of year? ~~YES~~ ~~NO~~
- b) Are the steam humidifiers operating now? ~~YES~~ ~~NO~~
- If YES, answer the questions below:
- c) Are chemicals used in the boiler or the pipes to protect against corrosion? ~~YES~~ ~~NO~~
- If YES, state names of chemicals:
- \_\_\_\_\_
- \_\_\_\_\_
- \_\_\_\_\_
25. Does this building have an air-chilling system? YES  NO
- a) Is the chilling system supposed to operate at this time of year? ~~YES~~ ~~NO~~
- b) Is the chilling system operating now? ~~YES~~ ~~NO~~
- If YES, answer the questions below:
- c) Are the condensate trays cleaned less often than once a week? ~~YES~~ ~~NO~~
- d) Is there slime or growth in the condensate trays? ~~YES~~ ~~NO~~
- e) Is there dirt on the cooling coils? ~~YES~~ ~~NO~~
- f) Are there mouldy odors in the system? ~~YES~~ ~~NO~~
26. Are the ventilation ducts or plenums insulated? YES  NO
- a) Is the insulation on the inside and directly exposed to the moving air? ~~YES~~ ~~NO~~
- b) Is it more than five years since the ducts or plenums were last cleaned? ~~YES~~ ~~NO~~
27. Are there any signs of condensation in ducts? (Check cold spots such as near inlets and after cooling coils first.) YES  NO

**APPENDIX "C"**

**AIR TEST EQUIPMENT**



PHOTOGRAPHS OF LEAKAGE TEST EQUIPMENT



BLDG "A"  
STAIRWELL SEALING

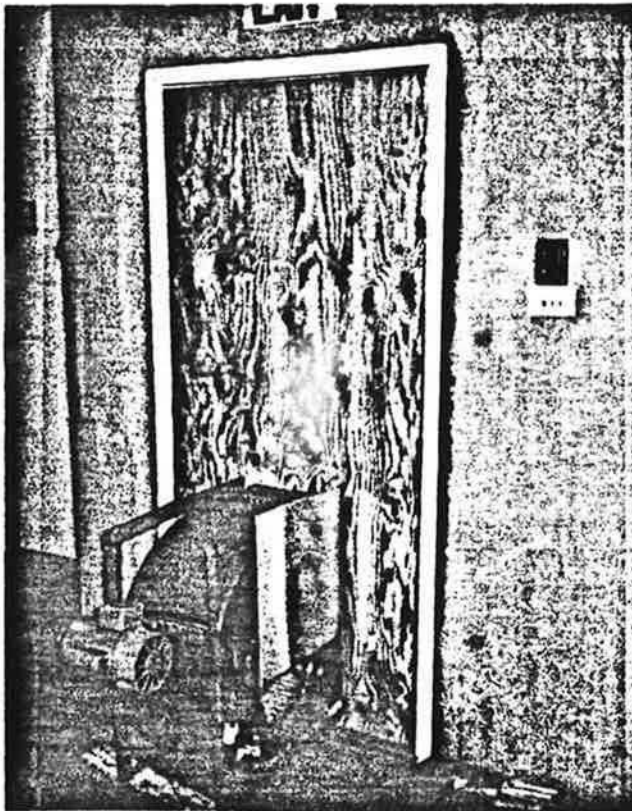
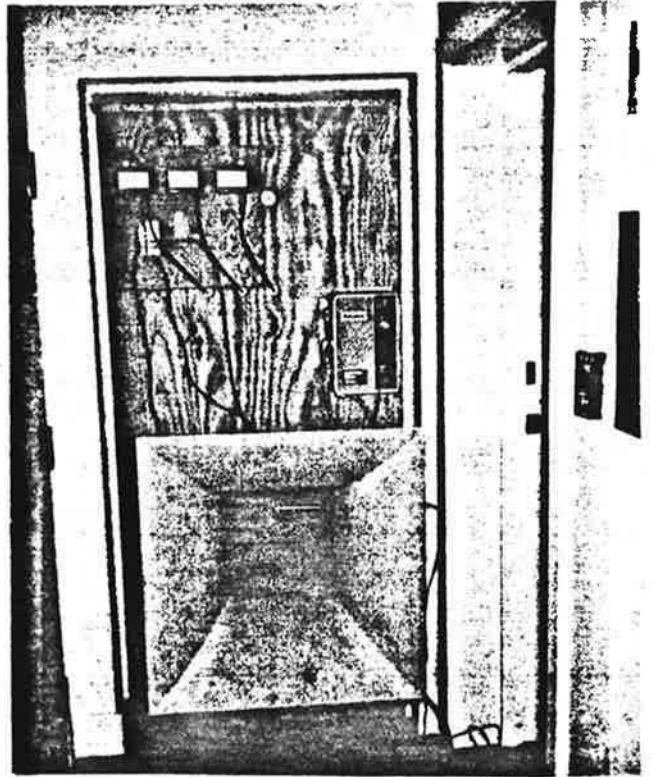

BALANCE FAN

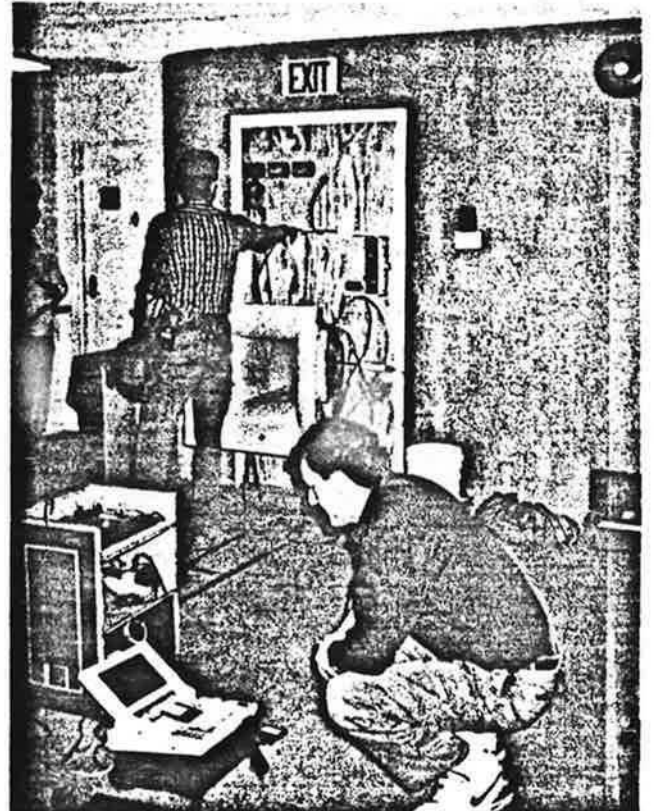

CONTROL / DATA



**KURZ INSTRUMENTS INC.**  
**2411 GARDEN ROAD**  
**MONTEREY, CA. 93940**  
**1-800-424-7356 (408) 646-5911**  
**FAX (408) 646 8901 TELEX 172275**  
**CALIBRATION DATA**  
**AND CERTIFICATION DOCUMENT**

UST.CODE:190-164

KURZ MODEL #: 435DC-MC

GAS: AIR

THE RANGE IS 3500 SFPM

-----  
FE M/N 400B LFE DUE DATE 5-23-91 LFE S/N 1078 LFE AREA N/A  
DVM S/N 9101 DVM DUE DATE 8-27-91 THERM. S/N 13033 THERM. DUE DATE 1-4-91  
AROMETER S.N. 115080Y1 FREQ. CNTR. S/N N/A FREQ. CNTR. DUE DATE N/A  
-----

SERIAL # DME-1288-H

CALIB. POINT	UNITS OF MEASURE	VELOCITY POINT	LINEAR VOLTAGE	BRIDGE VOLTAGE
1	SFPM	0.000	0.000	<u>2.848</u>
2	SFPM	175.000	0.250	<u>3.485</u>
3	SFPM	350.000	0.500	<u>4.353</u>
4	SFPM	700.000	1.000	<u>4.700</u>
5	SFPM	1050.000	1.500	<u>4.918</u>
6	SFPM	1400.000	2.000	<u>5.073</u>
7	SFPM	1750.000	2.500	<u>5.196</u>
8	SFPM	2100.000	3.000	<u>5.297</u>
9	SFPM	2450.000	3.500	<u>5.385</u>
10	SFPM	2800.000	4.000	<u>5.459</u>
11	SFPM	3150.000	4.500	<u>5.519</u>
12	SFPM	3500.000	5.000	<u>5.579</u>

-----  
THE RANGE OF 0 TO 3500 SFPM IS EQUAL TO THE LINEAR RANGE OF 0 TO 5 V.D.C.

TECHNICIAN *[Signature]* **25** DATE 3-14-91  
INSPECTOR *[Signature]* **(FT)** DATE 3-15-91

SPECIFICATIONS: All points indicated are within KURZ INSTRUMENTS INC. specifications; 3% of reading plus .5% of full scale  
STANDARD CONDITIONS: 25 degrees c and 760 mm Hg.  
VELOCITY OR MASS FLOW POINTS: Represents flow data points using NIST calibration.  
This form is to confirm that this instrument was calibrated with an NIST traceable mass flow meter and associated equipment. This calibration device is traceable to National Institute of Standards & Technology, Test Numbers 2.6/167716 A&B 232.09/209275.B.



**GREYSTONE**  
ENERGY SYSTEMS INC

# PRESSURE TRANSMITTERS

## T10

The MODUS pressure transmitter operates on the capacitance principle and is capable of sensing very low positive, negative, or differential pressures. In the capacitance cell, a very lightweight, responsive diaphragm deflects a small amount when pressure is applied. This deflection results in a change in capacitance which is then detected and processed electronically. Reliability and long life are inherent advantages of the solid-state design.

A wide selection of standard pressure ranges and electrical ratings is available.

The output of series T10 pressure transmitter is a voltage.



## FEATURES

- Virtually position insensitive even at very low pressure (0.01")
- Fast response time due to low internal volume
- No moving parts to wear out
- Solid-state circuitry for long life
- Compact size
- Low power consumption

## TYPICAL APPLICATIONS

- HVAC monitoring of:
  - Filter differential pressures
  - Fan static pressures
  - Clean room pressures
  - Variable air volume systems
  - Velocity pressures
- Medical and analytical instruments
- Liquid level monitoring
- Leak detection
- General automation

## SPECIFICATIONS

### General

- Accuracy is  $\pm 1\%$  of range (including non-linearity and hysteresis).
- Zero and span adjustments are non-interactive.
- Adjustments are by means of 20 turn potentiometers for fine resolution.

### Pressure

Ranges are: 0.1", 0.2", 0.3", 0.5", 1.0", 2.0", 3.0", 5.0", 10.0", Water Column

Measures differential, gage pressure or vacuum.

Suitable for air or inert gases.

Maximum safe momentary overpressure: 8 times pressure range.

Port connections: 3/16" Dia. suitable for -1/8" or 5/32" I.D. Tygon™ or polyurethane tubing, -1/4" O.D. polyethylene tubing.

Integral filters at both ports.

### Electrical

Operates between 9.5 and 32 Vdc (Protected against reversal of polarity)

Connections are by means of 3/8" terminal strip with #6 screw.

Output can sink or source 3.5 mA.

Output voltage is protected against short circuit.

E  
C

E 4G7 Carr  
014



**GREYSTONE**

ENERGY SYSTEMS INC

150 English Drive, Moncton, N.B. E1E 4G7 Canada  
Tel.: 506-853-3057 Fax: 506-853-6014

Pressure 91-3-9

# Burke 1000



Made in Canada by Canadians

The **Burke 1000** is a computerized stand alone DDC panel with full communication capabilities. An IBM compatible P.C. is used for the operator interface for viewing and programming the control systems. **Burke 1000** software has been designed with the user in mind being a menu prompt system for ease of operation.

## SYSTEM SPECIFICATION

### Hardware

Stainless Steel enclosure with Perspex window

32 inputs user configurable

ANALOGUE/DIGITAL

Volt free contact

Thermistor

0-5V.DC.

4-20MA

32 outputs user configurable

ANALOGUE/DIGITAL

0-10V.DC.

0-12V.DC. for solid state

relays or mechanical

relays

On/Off/Auto switches for each output

LED display for each output

### Software

32 PID Controllers

16 Time Schedules

8 Annual Schedules

32 Trend Logs

32 Digital Logs

16 Custom programmes enabling

Optimum Start

Optimum Stop

Load Shedding

Duty Cycling

Reaction Programmes

Input/Output Sequencing

32 User Codes 5 access levels

Digital and analogue alarms

Graphic and graphing capabilities

32 Point expansion boards - maximum

6 per Burke 1000

**APPENDIX "D"**

**AIR TIGHTNESS TEST MONITORING RESULTS**



Appendix D

Air tightness monitoring

# APARTMENT AIR TEST RESULTS

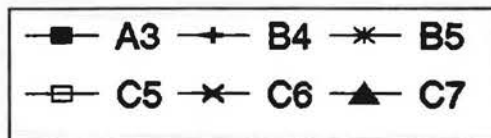
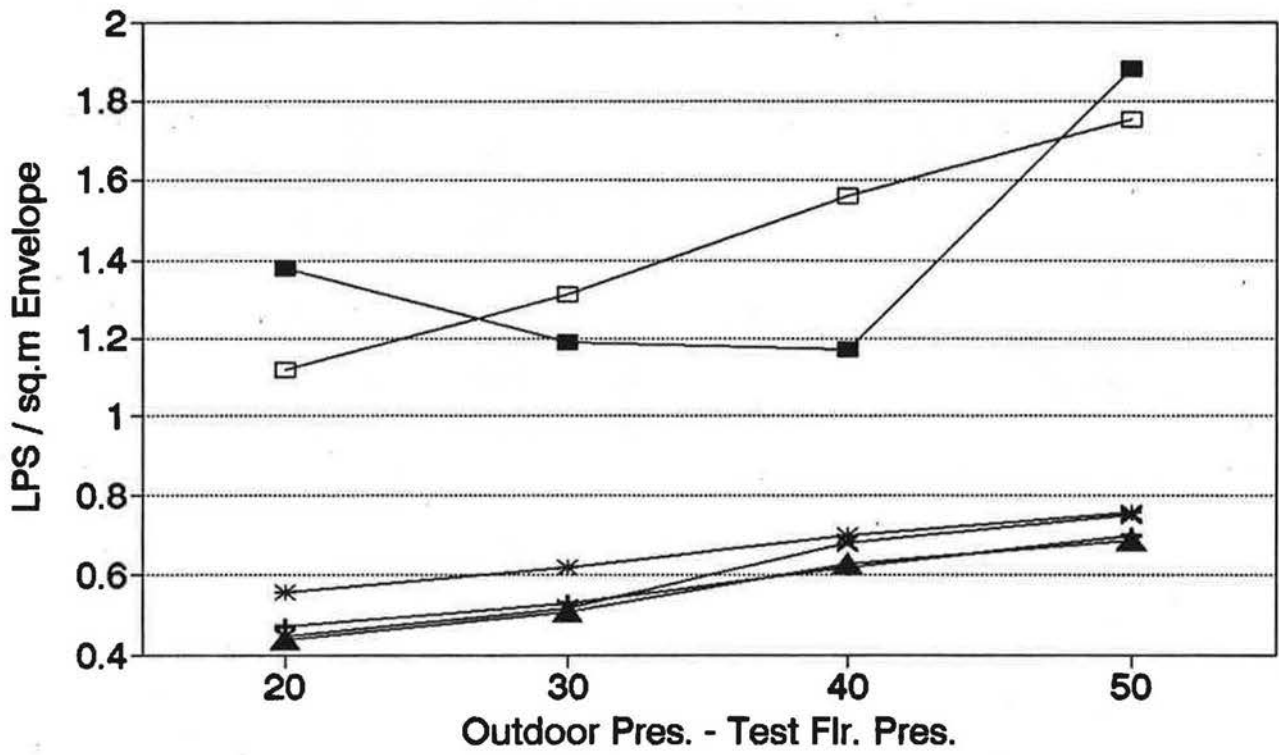

**BUILDING "A" - AIR TIGHTNESS TEST RESULTS**

	PA	CFM	LPS/SQ.M	wall AREA
<b>BOTH ELEV. SEALED</b>	20	800	1.38	273 SQ.M
<b>BOTH BAL FANS ON</b>	30	1000	1.73	2937 SQ.FT
	30	380	0.66	
	42	680	1.17	
	51	1100	1.90	
<b>1 ELEV.UNSEALED</b>	21	900	1.56	
<b>BOTH BAL FANS ON</b>	30	950	1.64	
	42	1100	1.90	
	48	1500	2.59	
<b>1 ELEV. UNSEALED</b>	22	1300	2.25	
<b>LOW FAN OFF</b>	30	1550	2.68	
	43	1950	3.37	
<b>1 ELEV. UNSEALED</b>	28	1100	1.90	
<b>UPPER FAN OFF</b>	41	1500	2.59	
	49	1800	3.11	
<b>1 ELEV. UNSEALED</b>	22	300	0.52	
<b>GARBAGE CH. UNSEALED</b>	30	650	1.12	
	40	950	1.64	
<b>ALL UNSEALED BUT</b>	21	600	1.04	
<b>1 ELEVATOR</b>	30	900	1.56	
	38	1150	1.99	
	51	1600	2.76	



# AIR TIGHTNESS TEST

## BLDG "A" - ALL & BOTH ELEV. SEALED

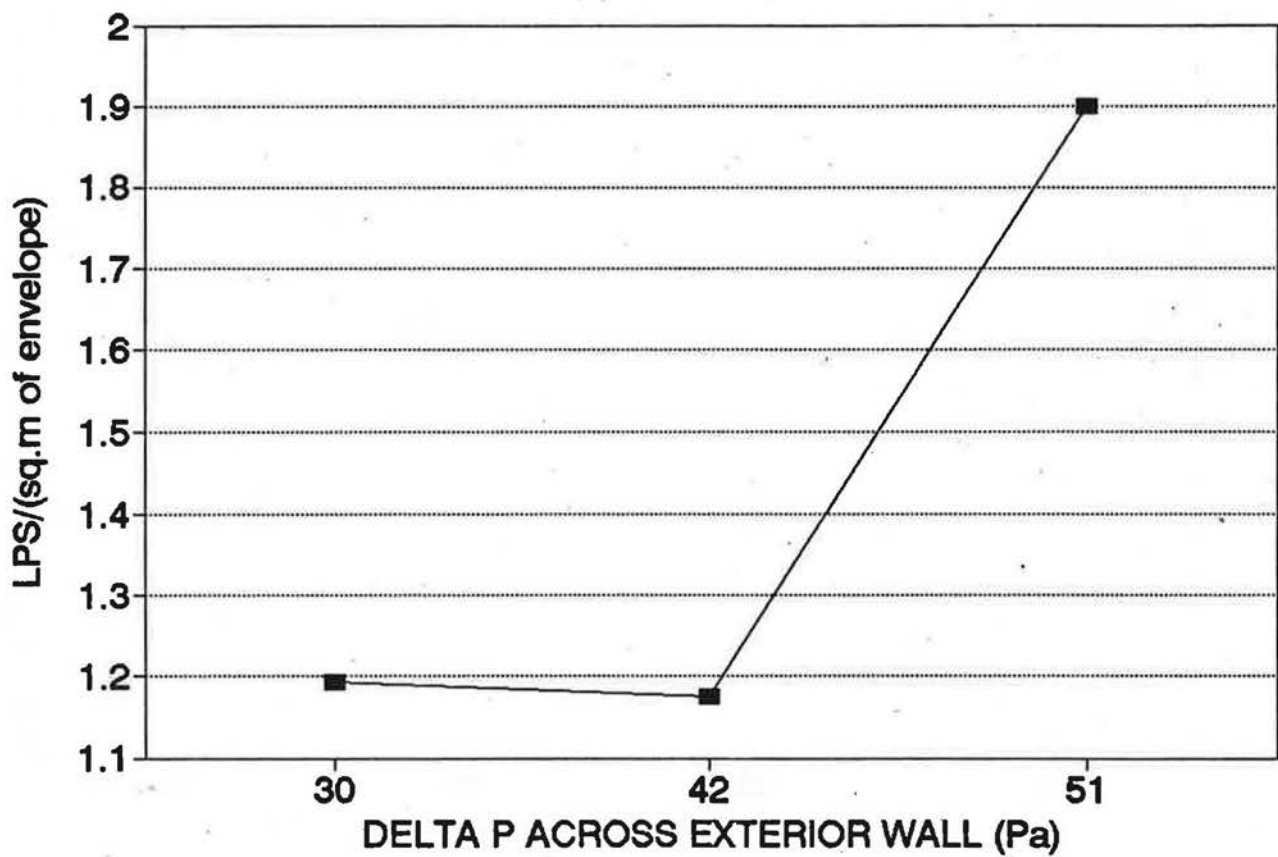

# AIR TIGHTNESS TEST

## BLDG "A" - ALL UNSEALED BUT 1 ELEV.

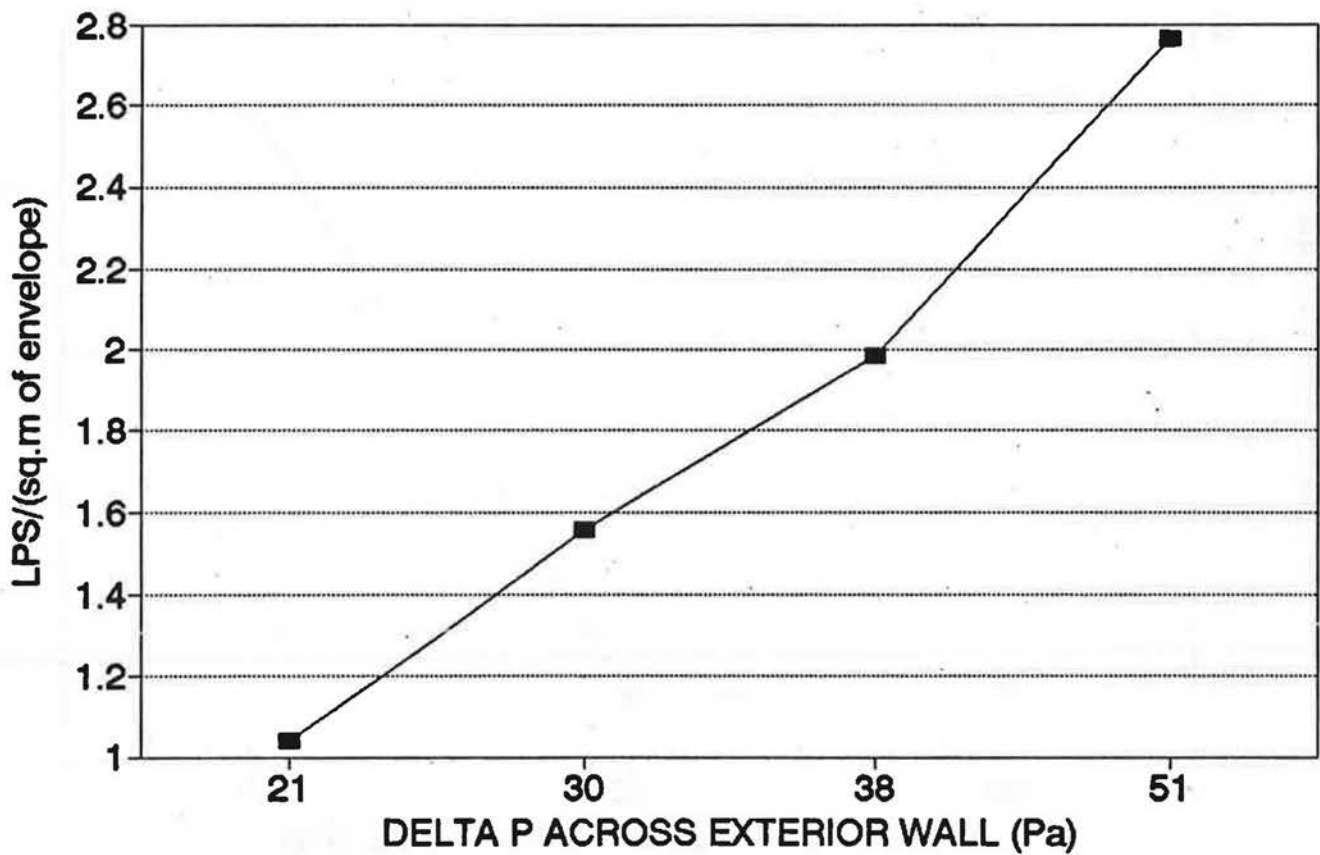

# AIR TIGHTNESS TEST

## BLDG "A" - ONE ELEV./ L.FAN OFF

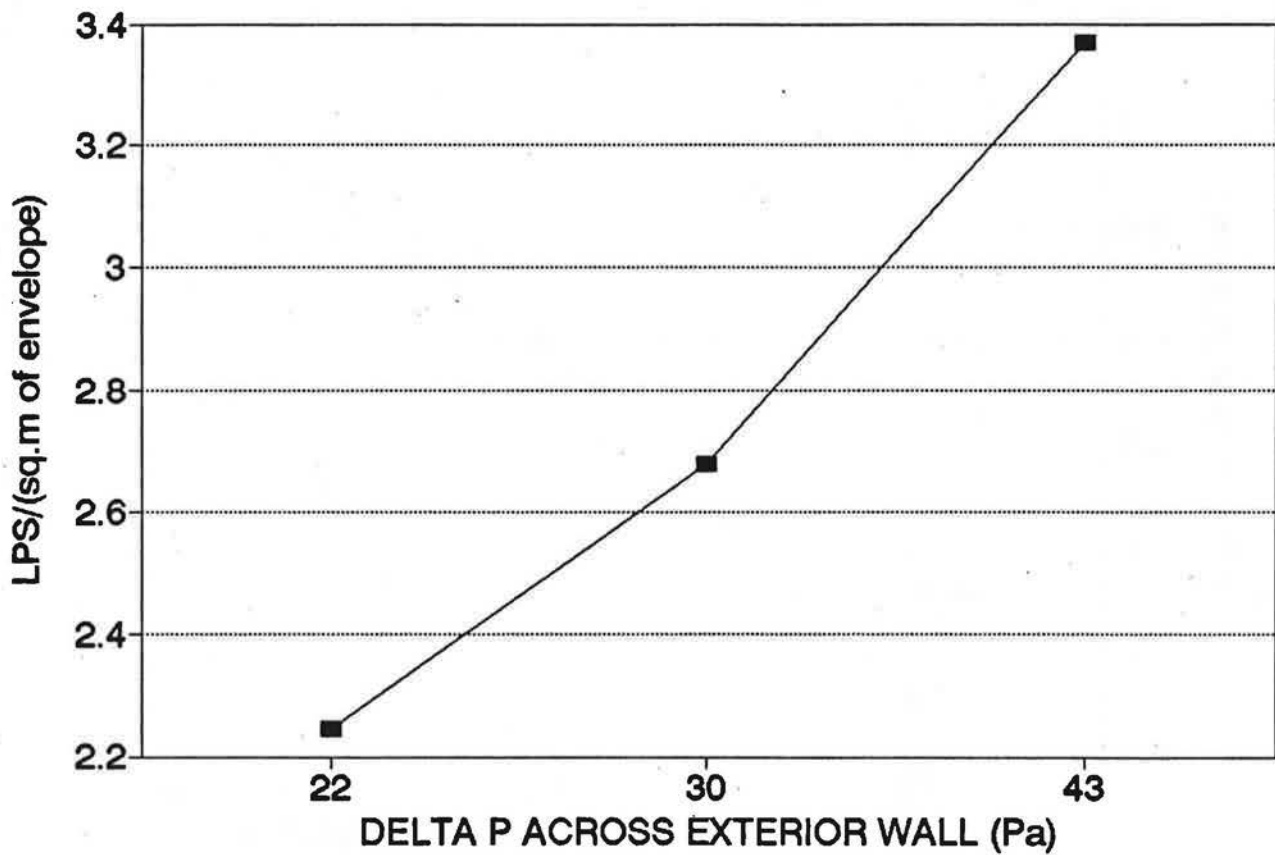

# AIR TIGHTNESS TEST

## BLDG "A" - ONE ELEV./ U.FAN OFF

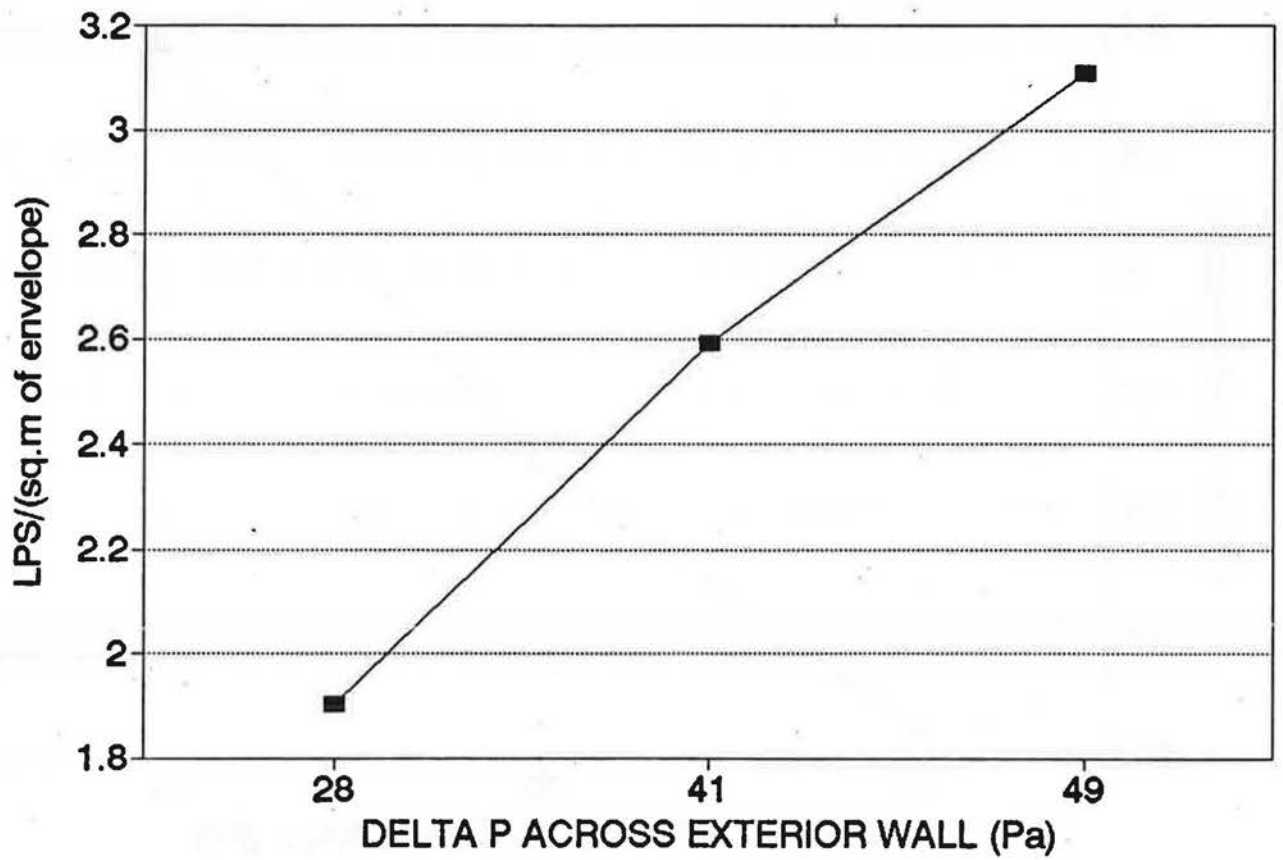

# AIR TIGHTNESS TEST

BLDG "A" - ALL SEALED BUT ONE ELEV.

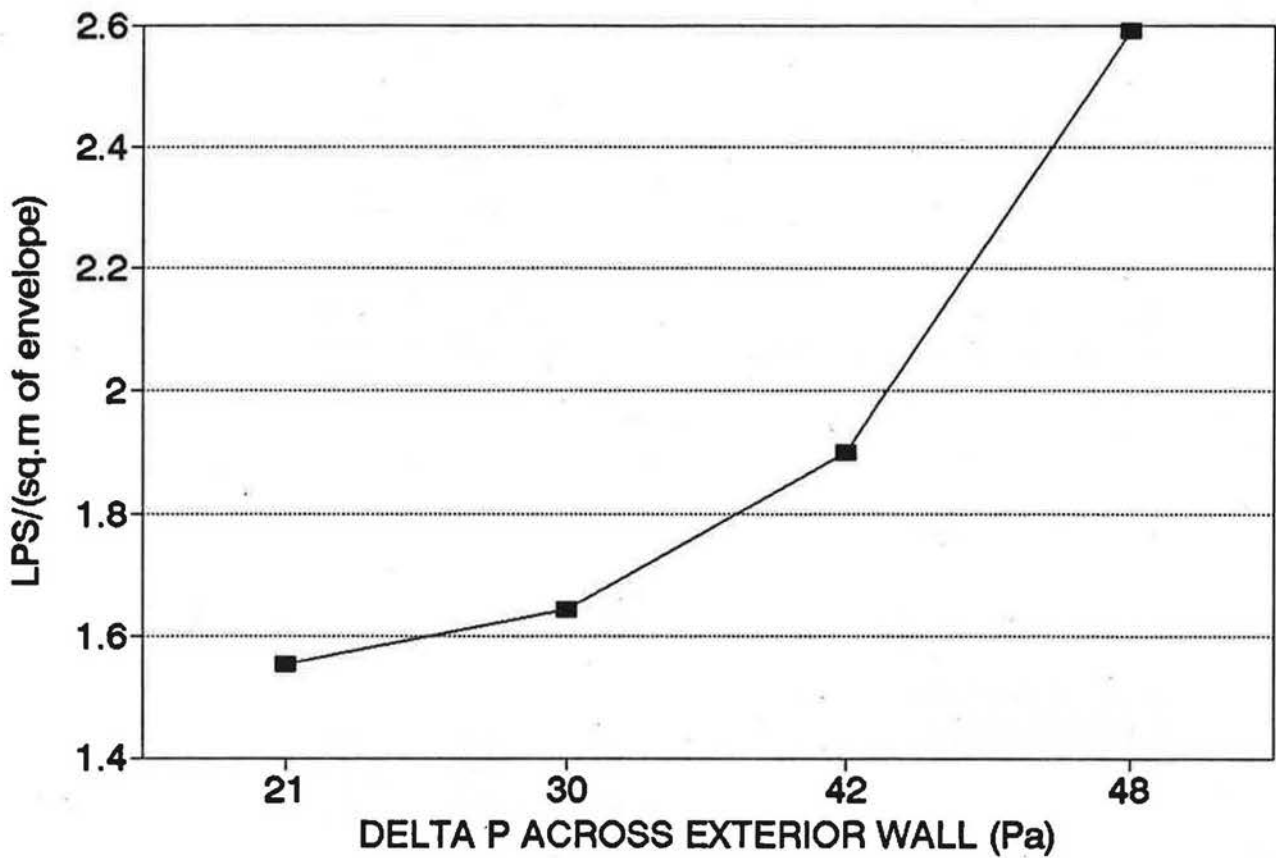

BUILDING "B"

	PA	CFM	LPS/SQ.M	wall AREA
Test floor = 3				
ELEV, GARBAGE CHT & STAIR SEALED	15	350	0.54	304 SQ.M
	20	350	0.54	3268 SQ.FT
	30	450	0.70	
	40	400	0.62	

Test Floor = 4				
ELEV, GARBAGE CHT & STAIR SEALED	20	300	0.47	
	30	340	0.53	
	40	400	0.62	
	50	450	0.70	
Elev. unsealed	50	810	1.26	
Elev.& garbage chute unsealed	50	900	1.40	
Elev,stair & G.C. unsealed	50	1475	2.29	

Test Floor = 5				
ELEV, GARBAGE CHT & STAIR SEALED	15	275	0.43	
	20	360	0.56	
	30	400	0.62	
	40	450	0.70	
Elev. unsealed	30	710	1.10	
Elev.& G.C. unsealed	30	800	1.24	
Elev,stair & G.C. unsealed	30	1170	1.82	

AIRTIGHTNESS TEST RESULTS  
 (AS PER CAN/CGSB - 149.10 - M86)

B4  
 Ext.Temp. = 9 C  
 Envelope Area = 304 m<sup>2</sup>  
 Pressure With Fan Sealed - Start: 1 Pa Finish: 1 Pa

MAY 8, 1991  
 Wind Speed = 50 km/h  
 Volume = 1375 m<sup>3</sup>

PRESS. (Pa)		TI (C)	FLOW(L/S)			RELATIVE ERROR(%)
MEAS'D.	ADJ'D.		MEAS'D.	ADJ'D.	FITTED	
50.0	49.0	23.0	212.00	206.55	203.81	1.33
40.0	39.0	23.0	188.00	183.17	184.35	0.65
30.0	29.0	23.0	160.00	155.89	161.84	3.82
20.0	19.0	23.0	142.00	138.35	134.39	2.86

C = 36.83366

n = .4395797

E.L.A. = 407.05 cm<sup>2</sup>

N.L.A. = 1.339 cm<sup>2</sup>/m<sup>2</sup>

Q @ 10Pa = 101.35 L/S

Q @ 50Pa = 205.63 L/S

Air Change per Hour @ 50Pa = 0.538

SXX= 1.579549E+09

SXY= 6.943375E+08

SYX= 3.123118E+08

SYX= 5.445019

Correlation Coefficient= .9885757

Relative Standard Error = 6.21%





# AIR TIGHTNESS TEST

## BUILDING "B" - 4th FLOOR

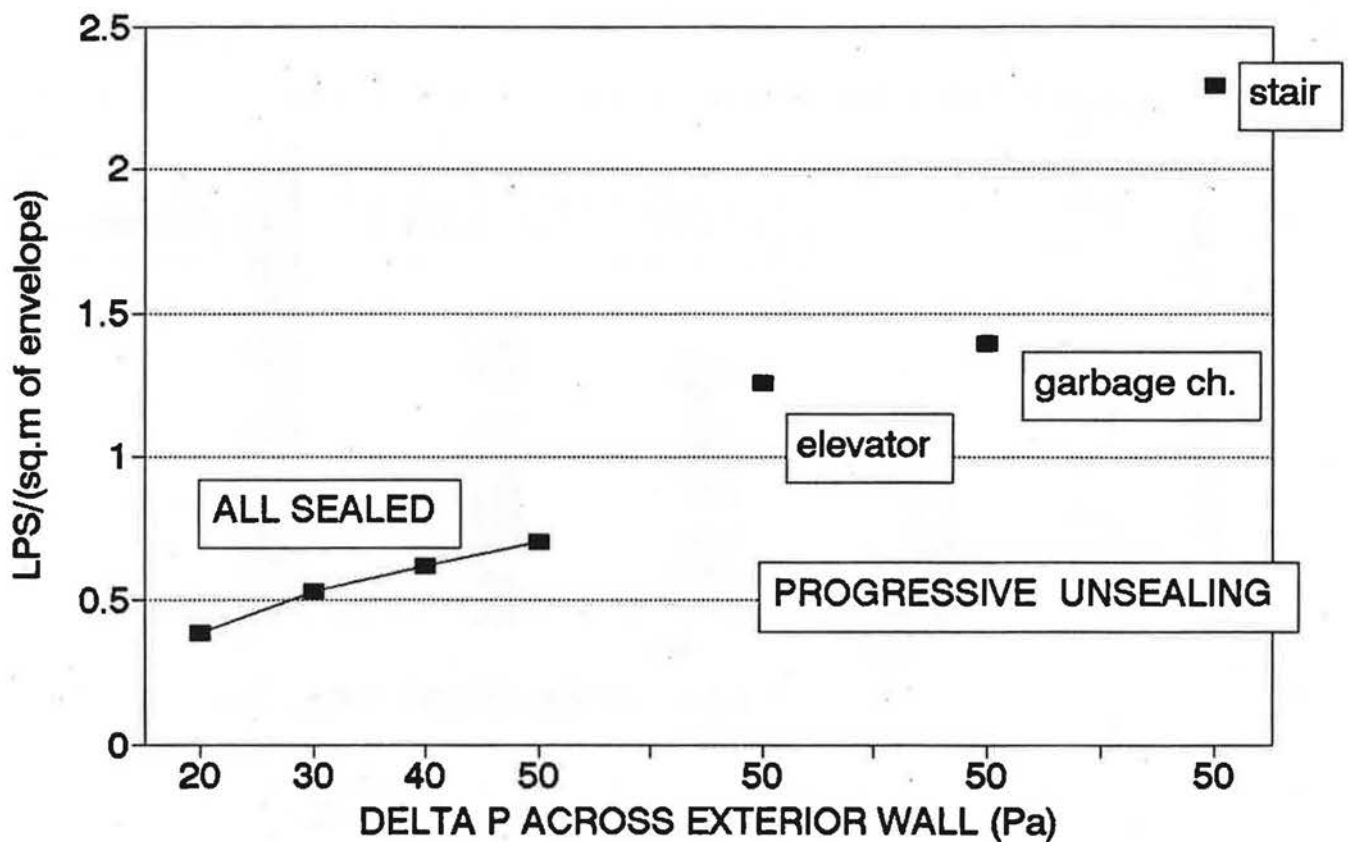

# AIR TIGHTNESS TEST

## BUILDING "B" - 4th FLOOR

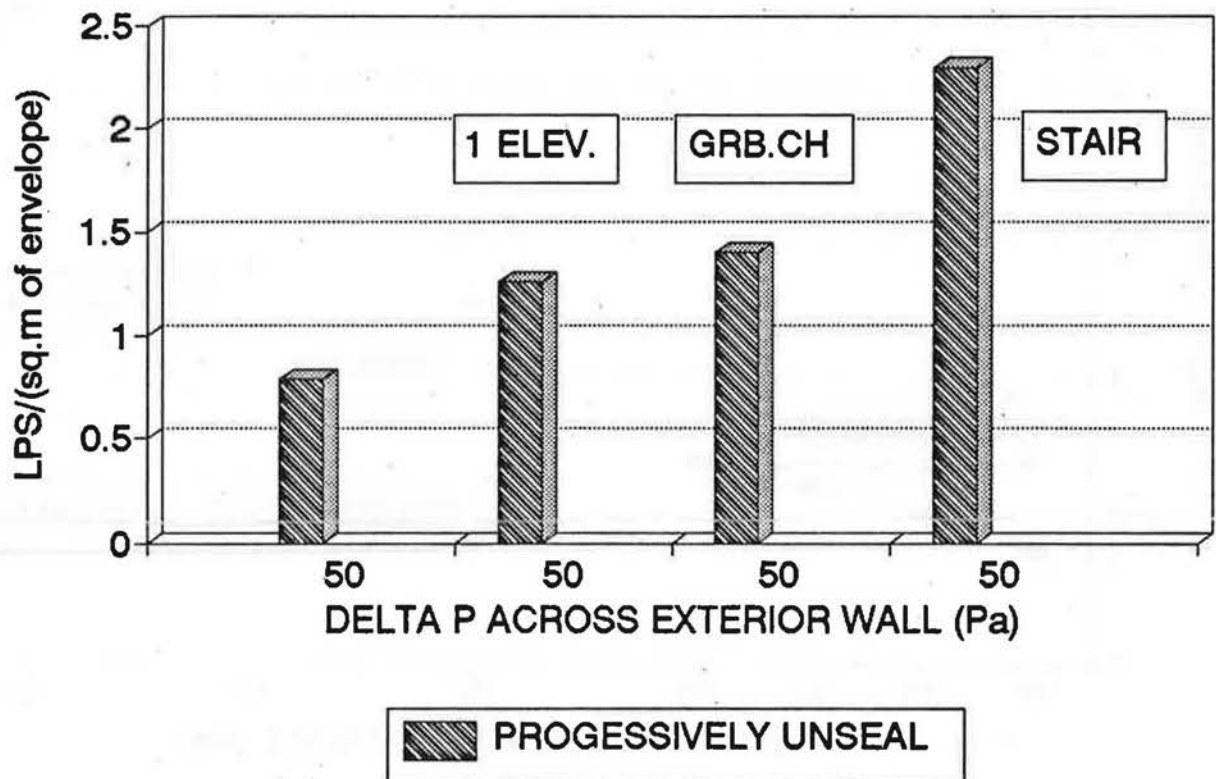

# AIR TIGHTNESS TEST

## BUILDING "B" - 5th FLOOR

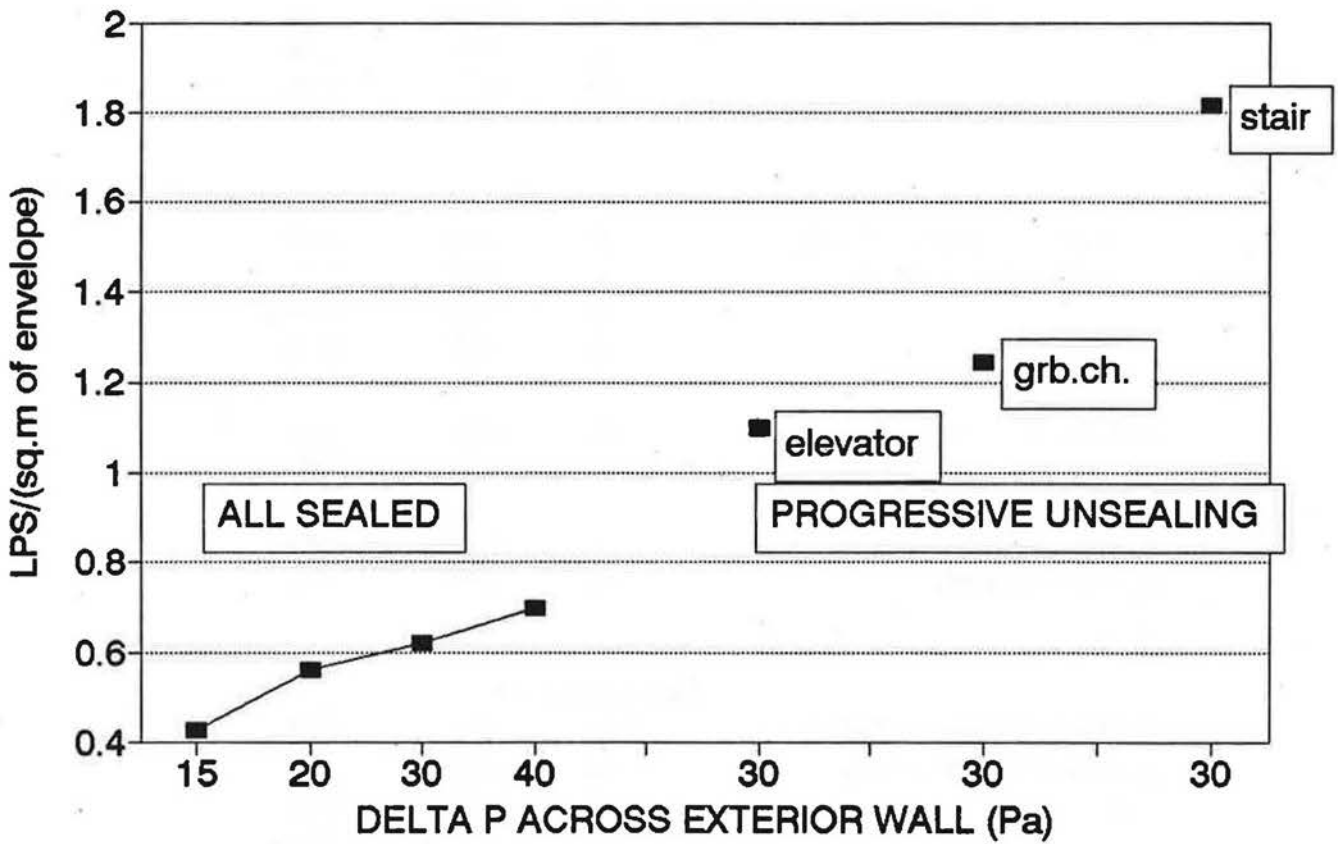

**BUILDING "C"**

PA	CFM	LPS/SQ.M	wall AREA
----	-----	----------	-----------

**Test Floor = 5**

<b>ELEV,GARBAGE CHT.&amp; STAIRWELL SEALED</b>	20	575	1.12	242 SQ.M
	30	670	1.31	2604 SQ.FT
	40	800	1.56	
	50	900	1.75	
elevator unsealed	50	2050	4.00	
elev & stair unsealed	50	2430	4.74	
elev,str & fireplaces unsealed	50	2450	4.78	
<b>LOWER BAL.FAN OFF</b>	20	955	1.86	
	30	1160	2.26	
	40	1425	2.78	
	50	1620	3.16	

**Test Floor = 6**

<b>ELEV,GARBAGE CHT.&amp; STAIRWELL SEALED</b>	20	230	0.45	
	30	265	0.52	
	40	350	0.68	
	50	385	0.75	
elevator unsealed	50	1400	2.73	
elev & stair unsealed	50	1780	3.47	
lower bal.fan off	50	1050	2.05	
upper bal.fan off	50	1360	2.65	

**Test Floor = 7**

<b>ELEV,GARBAGE CHT.&amp; STAIRWELL SEALED</b>	20	225	0.44	
	30	260	0.51	
	40	325	0.63	
	50	355	0.69	
elevator unsealed	50	1500	2.92	
elev & stair unsealed	50	1765	3.44	
elev,str & elect.rm unsealed	50	1740	3.39	



AIRTIGHTNESS TEST RESULTS  
 (AS PER CAN/CGSB - 149.10 - M86)

-----  
 C6  
 Ext.Temp. = 16 C  
 Envelope Area = 242 m<sup>2</sup>  
 Pressure With Fan Sealed - Start: 1 Pa Finish: 1 Pa  
 MAY 16, 1991  
 Wind Speed = 11 km/h  
 Volume = 935 m<sup>3</sup>

PRESS. (Pa)		TI (C)	FLOW (L/S)			RELATIVE ERROR (%)
MEAS'D.	ADJ'D.		MEAS'D.	ADJ'D.	FITTED	
50.0	49.0	21.0	182.00	180.12	180.83	0.40
40.0	39.0	21.0	165.00	163.29	158.28	3.07
30.0	29.0	21.0	125.00	123.71	133.15	7.63
20.0	19.0	21.0	109.00	107.87	104.03	3.57

C = 18.65491

n = .5836534

E.L.A. = 287.26 cm<sup>2</sup>

N.L.A. = 1.187 cm<sup>2</sup>/m<sup>2</sup>

Q @ 10Pa = 71.52 L/S

Q @ 50Pa = 182.98 L/S

Air Change per Hour @ 50Pa = 0.705

SXX= 7.486095E+08

SXY= 4.369285E+08

SYX= 2.656993E+08

SYX= 7.879439

Correlation Coefficient= .9796873

Relative Standard Error =11.28%





# AIR TIGHTNESS TEST

## BLDG "C" - 5TH FLOOR

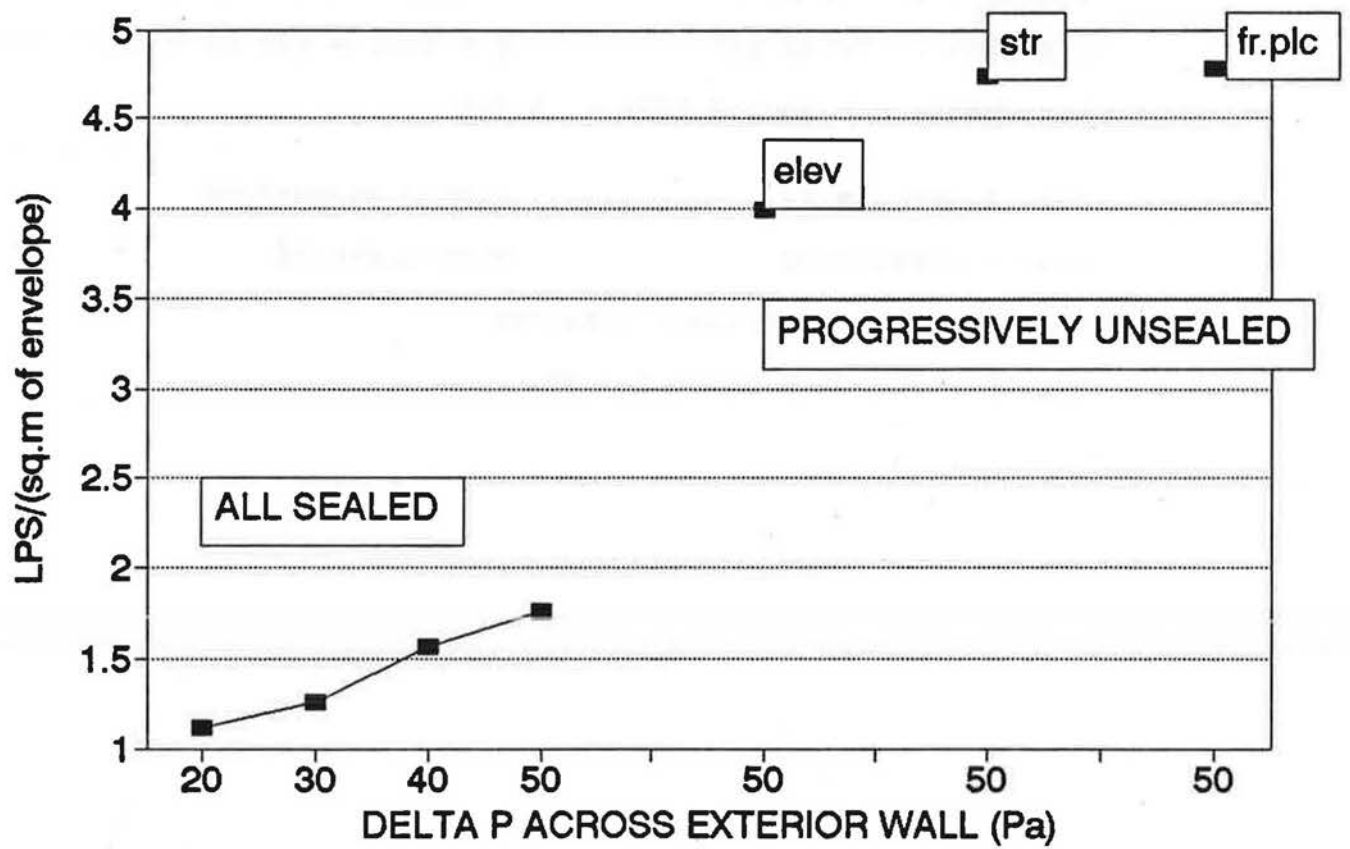

# AIR TIGHTNESS TEST

## BLDG "C" - 5TH - LOWER FAN OFF

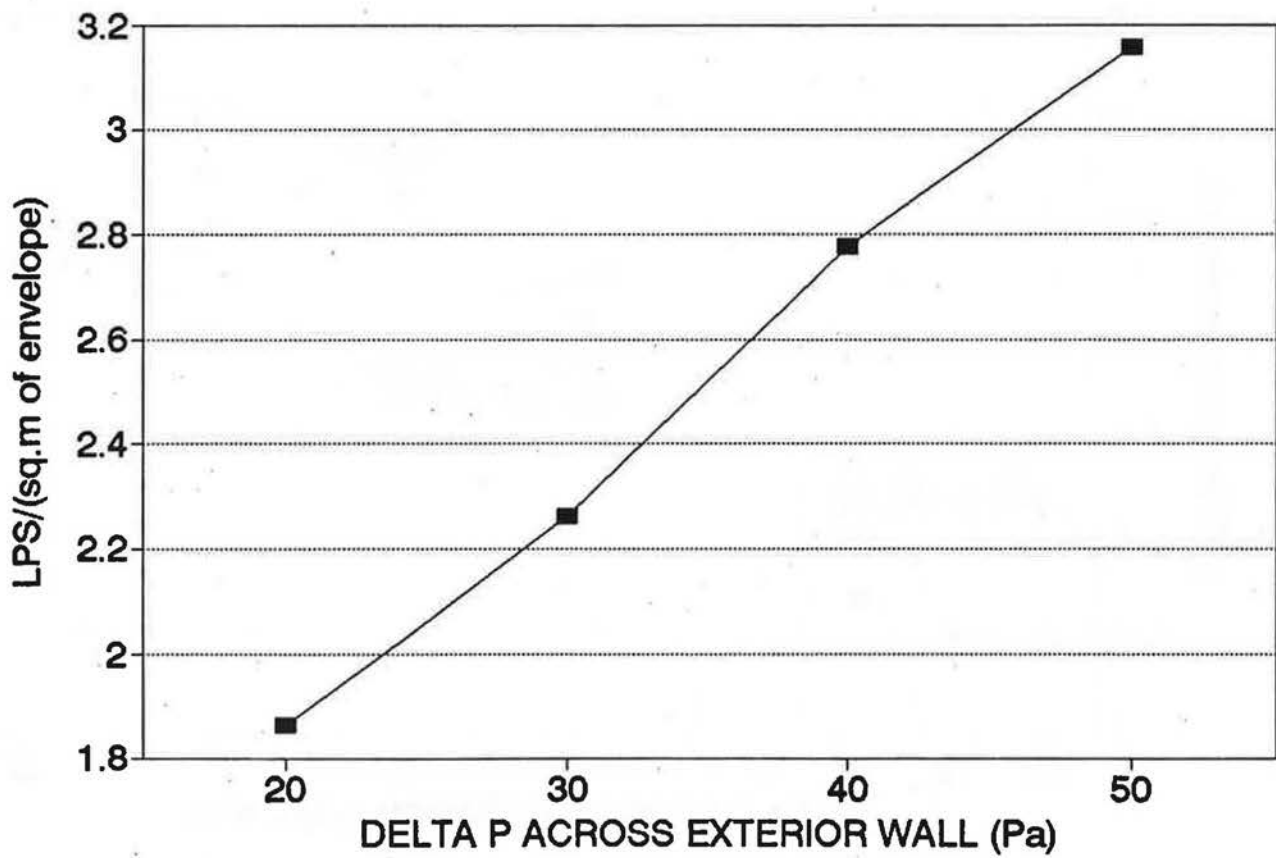

# AIR TIGHTNESS TEST

## BLDG "C" - 6TH FLOOR

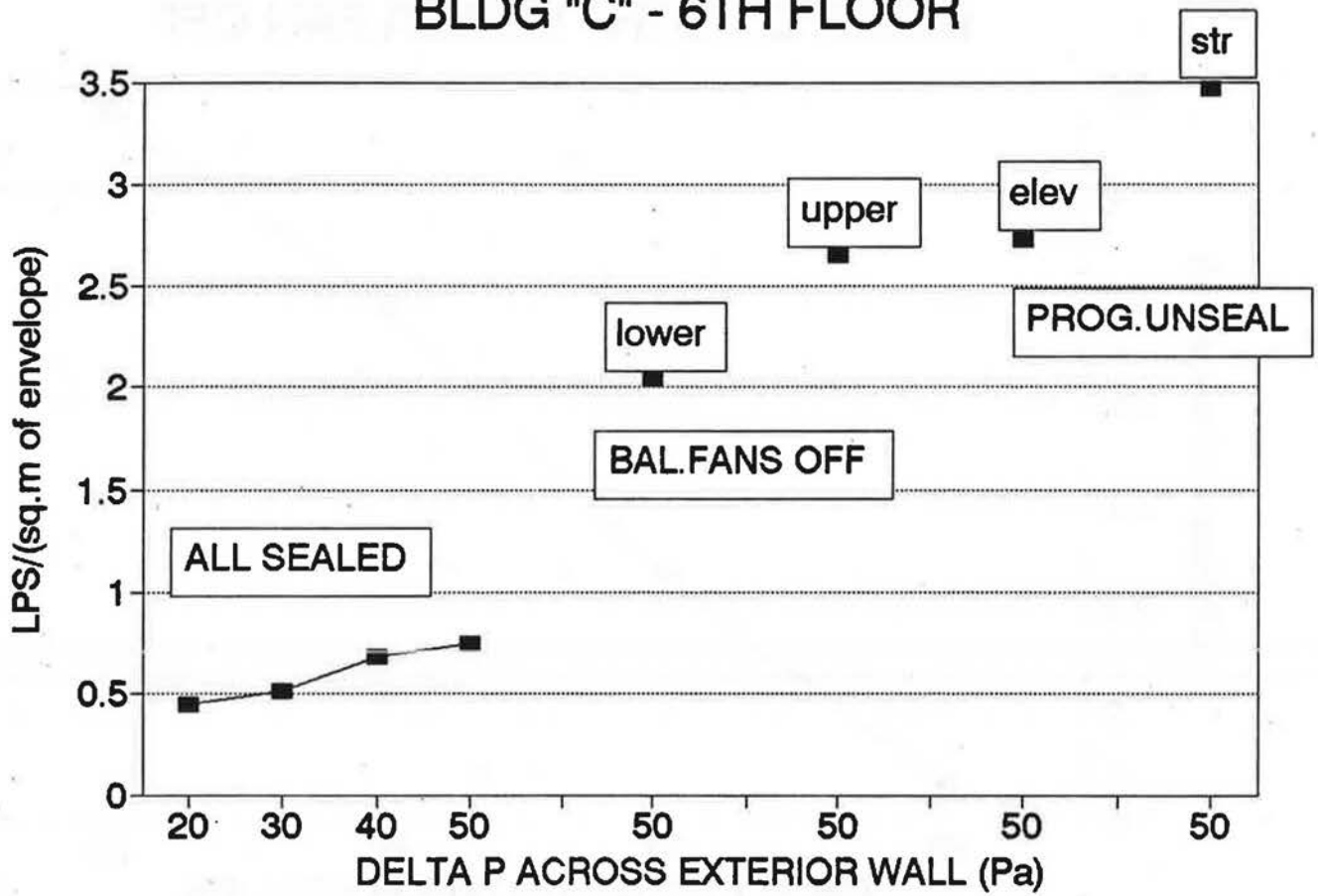

# AIR TIGHTNESS TEST

## BLDG "C" - 7TH FLOOR

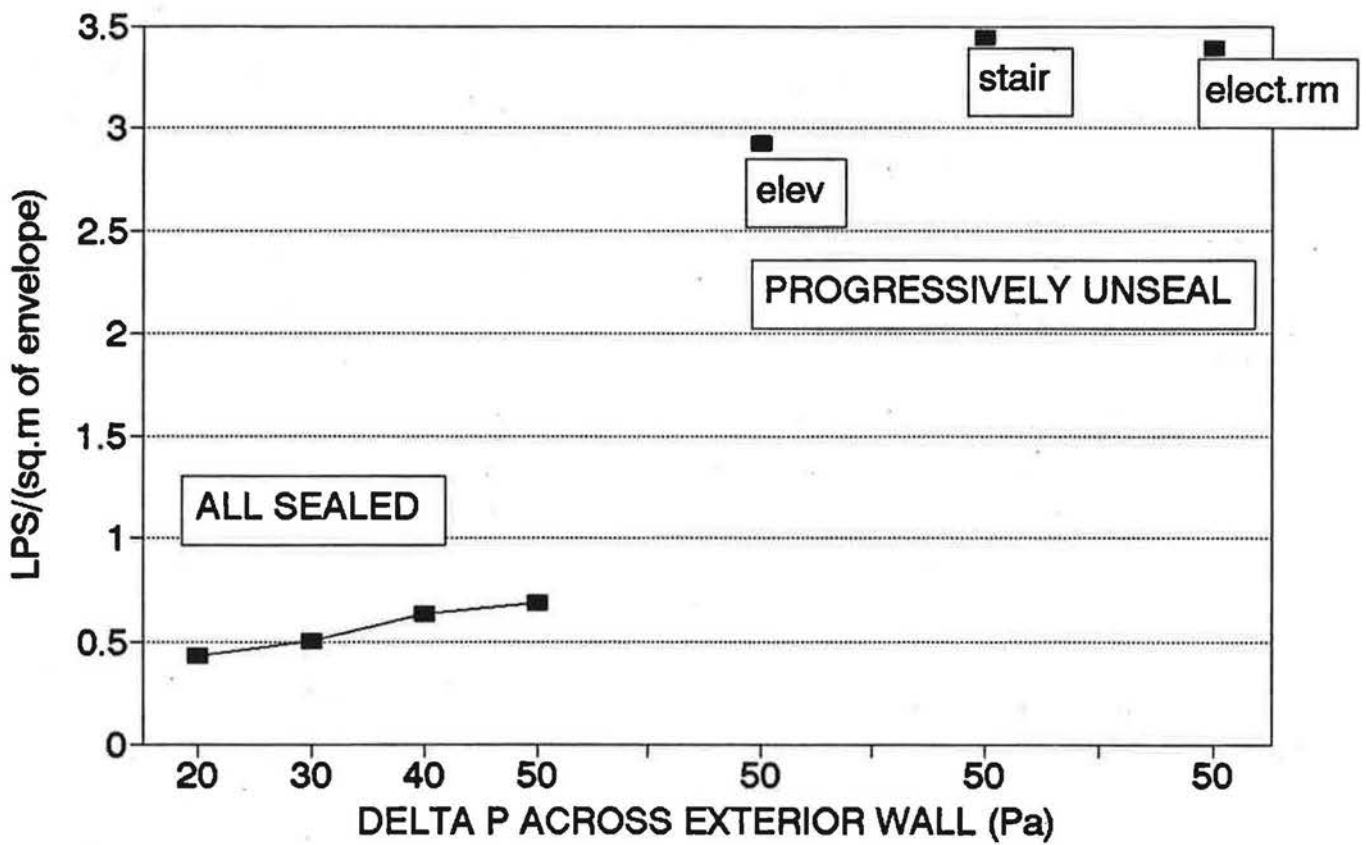

**APPENDIX "E"**

**FIELD DATA FROM AIR LEAKAGE TESTS**

**LEGEND**

- Input 3** = Pres. dif. (Pa) between test & lower floor.
- Input 4** = Pres. dif. (Pa) between test & upper floor.
- Input 5** = Pres. dif. (Pa) between test floor & outdoors.
- Input 8** = Test floor temperature.
- Input 11** = Outdoor temperature.
- Input 12** = Bell mouth velocity (fpm).

System:  
Panel : 1

Wed May 08 12:05:03 1991

ANALOG MONITOR 1 -- AIR-INF BLDG 'B' - 3<sup>RD</sup> FLR.

Date / Time	1- IN3 Pa	1- IN4 Pa	1- IN5 Pa	1- IN8 deg.C	1- IN11 deg.C	1- IN12
May 08 12:00	2.4	2.1	40.8	22.1	9.8	405.8
May 08 12:00	2.6	2.0	39.1	22.1	9.8	384.8
May 08 12:00	2.1	1.8	39.6	22.1	9.8	402.8
May 08 12:00	1.4	1.6	39.4	22.1	9.8	429.5
May 08 12:00	2.7	2.2	40.6	22.1	9.8	468.5
May 08 12:00	1.7	2.1	40.6	22.1	9.8	418.3
May 08 12:00	1.2	1.6	40.5	22.1	9.8	386.3
May 08 12:00	2.3	2.1	40.1	22.1	9.8	368.8
May 08 12:00	2.1	2.0	39.8	22.1	9.8	417.8
May 08 12:00	20.0	12.5	55.9	22.1	9.8	956.0
May 08 12:00	9.1	6.1	35.1	22.1	9.8	843.5
May 08 12:00	8.7	4.7	41.8	22.1	9.8	827.5
May 08 12:01	14.4	10.5	51.0	22.1	9.8	854.0
May 08 12:01	3.0	2.1	30.2	22.1	9.8	824.0
May 08 12:01	9.5	5.7	43.7	22.1	9.8	830.0
May 08 12:01	14.0	8.5	43.3	22.1	9.8	752.5
May 08 12:01	4.8	2.3	32.3	22.1	9.8	755.0
May 08 12:01	5.4	2.9	36.3	22.1	9.8	672.5
May 08 12:01	7.7	4.0	41.4	22.1	9.8	632.5
May 08 12:01	13.8	8.3	48.0	22.1	9.8	741.5
May 08 12:01	6.2	4.6	39.9	22.1	9.8	618.5
May 08 12:01	2.6	2.2	37.7	22.1	9.8	543.0
May 08 12:01	1.4	1.4	36.6	22.1	9.7	433.5
May 08 12:01	2.2	1.8	38.9	22.1	9.7	385.0
May 08 12:02	1.6	1.5	39.8	22.1	9.7	369.3
May 08 12:02	1.9	1.9	39.5	22.1	9.7	360.0
May 08 12:02	1.2	1.4	39.5	22.1	9.7	374.3
May 08 12:02	2.7	2.2	39.4	22.1	9.7	406.0
May 08 12:02	1.9	2.2	40.9	22.1	9.7	459.8
May 08 12:02	1.2	1.7	40.0	22.1	9.8	424.3
May 08 12:02	1.6	1.9	39.9	22.1	9.8	361.0
May 08 12:02	1.0	1.3	40.5	22.1	9.8	370.0
May 08 12:02	1.1	1.5	39.8	22.1	9.8	358.3
May 08 12:02	5.5	2.1	36.7	22.1	9.8	350.5
May 08 12:02	6.7	2.8	39.3	22.1	9.8	422.8
May 08 12:02	4.8	2.5	39.5	22.1	9.8	423.5
May 08 12:03	5.0	2.6	40.3	22.1	9.8	401.8
May 08 12:03	11.6	4.3	42.0	22.1	9.8	453.5
May 08 12:03	9.2	3.0	40.8	22.1	9.8	386.3
May 08 12:03	10.9	4.3	41.6	22.1	9.8	456.8
May 08 12:03	13.1	4.9	41.4	22.1	9.8	472.3
May 08 12:03	12.4	5.0	44.2	22.1	9.8	476.3
May 08 12:03	5.1	2.4	40.4	22.1	9.8	364.8
May 08 12:03	9.8	4.5	42.3	22.1	9.8	424.0
May 08 12:03	15.4	9.0	45.5	22.1	9.8	491.5
May 08 12:03	6.9	2.5	30.6	22.1	9.8	667.5
May 08 12:03	13.4	6.8	49.6	22.0	9.8	931.5
May 08 12:03	12.9	9.7	44.6	22.0	9.8	935.5
May 08 12:04	4.5	3.0	35.4	22.0	9.8	753.5
May 08 12:04	7.6	4.9	44.5	22.0	9.8	762.5
May 08 12:04	7.7	5.5	43.1	22.0	9.8	557.0
May 08 12:04	4.7	2.6	39.2	22.0	9.8	603.0
May 08 12:04	5.9	2.7	39.2	22.0	9.8	509.0
May 08 12:04	11.8	4.0	40.0	22.0	9.8	468.5
May 08 12:04	9.8	3.5	39.9	22.0	9.8	430.8



AIR INFILTRATION TESTS - RESULTS

BLDG 'B' - 3RD FLR.

LEGEND:

DPB denotes pres. dif (Pa) between test & lower floors  
 DPU denotes pres. dif (Pa) between test & upper floors  
 DPO denotes pres. dif (Pa) between test floor & outdoors  
 Ti denotes test floor temperature (deg.C)  
 To denotes outdoor temperature  
 BM Vel denotes bell mouth velocity (fpm)

System:  
 Panel : 1

Date / Time	DPB	DPU	DPO	Ti	To	BM Vel
	1- IN3 Pa	1- IN4 Pa	1- IN5 Pa	1- IN8 deg.C	1- IN11 deg.C	1- IN12
May 08 11:51	1.0	0.9	28.7	22.2	9.2	535.5
May 08 11:51	0.9	0.9	28.7	22.2	9.2	456.5
May 08 11:51	0.8	0.9	30.4	22.2	9.2	420.0
May 08 11:51	0.8	1.0	31.5	22.2	9.2	430.0
May 08 11:51	0.8	0.9	29.6	22.2	9.2	607.0
May 08 11:51	0.8	0.8	28.6	22.2	9.2	582.0
May 08 11:51	0.8	0.8	28.9	22.2	9.2	527.5
May 08 11:51	0.8	0.8	29.8	22.2	9.2	461.5
May 08 11:51	0.9	1.2	32.2	22.2	9.2	544.0
May 08 11:52	0.8	1.1	32.3	22.2	9.2	558.0
May 08 11:52	0.8	1.2	28.9	22.2	9.2	620.0
May 08 11:52	0.8	0.9	27.0	22.2	9.2	567.0
May 08 11:52	1.0	1.0	29.3	22.2	9.2	481.3
May 08 11:52	1.1	1.2	31.7	22.2	9.2	467.0
May 08 11:52	1.0	1.4	32.7	22.2	9.2	536.0
May 08 11:52	0.9	1.1	30.2	22.2	9.2	607.0
May 08 11:52	0.9	0.8	27.4	22.2	9.2	633.5
May 08 11:52	0.9	1.0	28.4	22.2	9.2	588.0
May 08 11:52	1.9	1.3	32.3	22.2	9.2	582.5
May 08 11:52	1.1	1.1	29.9	22.2	9.2	705.3
May 08 11:52	0.8	0.8	29.9	22.2	9.2	410.0
May 08 11:53	0.8	0.7	29.6	22.2	9.2	318.3
May 08 11:53	0.8	0.8	30.4	22.2	9.2	521.5

AIR INFILTRATION TESTS - RESULTS

BLDG 'B' - 3<sup>RD</sup> FLOOR

LEGEND:

DPB denotes pres. dif (Pa) between test & lower floors  
 DPU denotes pres. dif (Pa) between test & upper floors  
 DPO denotes pres. dif (Pa) between test floor & outdoors  
 Ti denotes test floor temperature (deg.C)  
 To denotes outdoor temperature  
 BM Vel denotes bell mouth velocity (fpm)

System:  
 Panel : 1

Date / Time	DPB	DPU	DPO	Ti	To	BM Vel
	1- IN3 Pa	1- IN4 Pa	1- IN5 Pa	1- IN6 deg.C	1- IN11 deg.C	1- IN12
May 08 11:15	2.0	2.3	20.5	21.5	10.5	275.0
May 08 11:15	2.1	2.9	19.5	21.5	10.5	320.5
May 08 11:15	2.0	2.2	19.9	21.5	10.6	301.5
May 08 11:16	2.3	1.9	20.1	21.5	10.6	281.5
May 08 11:16	2.8	1.8	20.0	21.5	10.6	276.8
May 08 11:16	3.1	1.9	19.6	21.5	10.6	260.3
May 08 11:16	3.7	2.0	20.3	21.5	10.6	285.0
May 08 11:16	3.9	2.7	19.5	21.5	10.6	284.3
May 08 11:16	3.9	2.1	19.7	21.5	10.6	283.5
May 08 11:16	4.6	3.2	18.3	21.5	10.6	324.0
May 08 11:16	5.5	4.1	20.8	21.5	10.6	356.5
May 08 11:16	3.6	3.1	20.2	21.5	10.6	300.8
May 08 11:16	1.8	2.4	18.7	21.5	10.6	276.8
May 08 11:16	5.9	4.0	19.7	21.5	10.6	304.3
May 08 11:16	4.2	3.5	20.5	21.5	10.6	323.3
May 08 11:17	2.5	2.3	22.5	21.5	10.6	273.5
May 08 11:17	1.1	1.0	20.1	21.5	10.6	464.8
May 08 11:17	0.8	0.9	19.1	21.5	10.6	436.8
May 08 11:17	0.9	1.9	18.9	21.5	10.6	371.1
May 08 11:17	1.8	3.6	21.6	21.5	10.6	351.1
May 08 11:17	1.1	2.1	19.4	21.5	10.6	273.5
May 08 11:17	1.9	3.1	19.4	21.5	10.6	276.5
May 08 11:17	1.6	2.7	21.5	21.5	10.5	291.5
May 08 11:17	1.0	1.9	20.1	21.5	10.5	252.0
May 08 11:17	0.9	1.5	20.9	21.5	10.4	232.8
May 08 11:17	1.0	1.6	19.4	21.5	10.4	221.8
May 08 11:17	2.0	2.5	18.9	21.5	10.4	227.5
May 08 11:18	2.5	3.2	20.2	21.5	10.4	276.5
May 08 11:18	1.5	2.4	19.3	21.5	10.4	262.3
May 08 11:18	3.1	5.1	21.6	21.5	10.3	317.0
May 08 11:18	1.1	2.1	21.5	21.5	10.3	268.8
May 08 11:18	0.8	1.2	20.3	21.5	10.3	206.0
May 08 11:18	0.8	1.3	19.2	21.6	10.3	196.8
May 08 11:18	0.8	1.5	21.3	21.6	10.3	231.3
May 08 11:18	0.9	1.4	18.6	21.6	10.3	478.5
May 08 11:18	0.8	1.6	20.8	21.6	10.3	327.3
May 08 11:18	0.8	1.7	20.0	21.6	10.4	259.0
May 08 11:18	1.3	2.1	19.8	21.6	10.5	266.0
May 08 11:18	1.0	1.4	18.9	21.6	10.5	294.5
May 08 11:19	2.0	3.2	23.6	21.6	10.5	355.3
May 08 11:19	2.4	1.0	15.4	21.6	10.5	662.5
May 08 11:19	5.0	0.7	20.7	21.6	10.5	628.5
May 08 11:19	2.9	0.7	19.3	21.6	10.5	840.0
May 08 11:19	5.4	0.7	21.9	21.6	10.5	845.5
May 08 11:19	4.6	0.7	21.6	21.6	10.5	675.0
May 08 11:19	3.7	0.7	17.9	21.6	10.4	710.5
May 08 11:19	3.2	0.7	15.7	21.6	10.4	720.0
May 08 11:19	4.0	4.3	20.3	21.6	10.3	574.0
May 08 11:19	1.2	2.4	20.2	21.6	10.2	313.0
May 08 11:19	1.3	4.4	21.3	21.6	10.2	304.3

AIR INFILTRATION TESTS - RESULTS

BLDG. 'B' FLR 3

LEGEND:

DPB denotes pres. dif (Pa) between test & lower floors  
 DPU denotes pres. dif (Pa) between test & upper floors  
 DPO denotes pres. dif (Pa) between test floor & outdoors  
 Ti denotes test floor temperature (deg.C)  
 To denotes outdoor temperature  
 BM Vel denotes bell mouth velocity (fpm)

System:

Panel : 1

Date / Time	DPB	DPU	DPO	Ti	To	BM Vel
	1- IN3 Pa	1- IN4 Pa	1- IN5 Pa	1- IN8 deg.C	1- IN11 deg.C	1- IN12
May 08 11:01	1.1	3.2	14.3	21.5	9.4	245.9
May 08 11:01	4.2	6.6	11.6	21.5	9.4	303.5
May 08 11:01	5.1	5.8	13.8	21.5	9.4	388.3
May 08 11:01	4.5	4.0	16.5	21.5	9.4	304.5
May 08 11:01	1.4	2.0	17.3	21.5	9.4	276.3
May 08 11:01	0.9	1.5	14.7	21.5	9.4	487.0
May 08 11:01	0.9	2.0	15.3	21.5	9.4	298.3
May 08 11:01	1.1	1.4	12.6	21.5	9.4	626.0
May 08 11:01	3.3	4.4	15.1	21.5	9.4	335.0
May 08 11:01	1.3	3.5	14.9	21.5	9.4	305.3
May 08 11:02	2.4	4.1	13.8	21.5	9.4	297.5
May 08 11:02	3.3	5.0	15.0	21.5	9.4	341.5
May 08 11:02	1.7	3.7	16.5	21.5	9.4	303.3
May 08 11:02	1.0	3.2	15.8	21.5	9.4	270.0
May 08 11:02	0.8	2.1	15.1	21.5	9.4	216.3
May 08 11:02	1.0	2.9	15.2	21.5	9.4	253.5
May 08 11:02	3.0	4.1	14.1	21.5	9.4	265.5
May 08 11:02	1.6	2.9	14.4	21.5	9.4	212.5
May 08 11:02	1.0	1.5	16.2	21.5	9.4	302.5
May 08 11:02	0.9	0.8	14.2	21.5	9.4	713.0
May 08 11:02	2.2	1.2	15.0	21.5	9.4	533.0
May 08 11:02	3.9	2.2	12.7	21.5	9.4	527.0
May 08 11:03	3.2	2.7	16.7	21.5	9.4	400.8
May 08 11:03	1.3	1.4	16.0	21.5	9.4	294.0
May 08 11:03	1.1	1.1	<u>15.0</u>	21.5	9.4	565.0
May 08 11:03	1.1	1.1	15.3	21.5	9.4	367.0
May 08 11:03	5.0	3.3	11.6	21.5	9.4	549.0
May 08 11:03	3.2	3.0	15.7	21.5	9.4	540.5
May 08 11:03	3.8	2.9	13.6	21.5	9.4	538.5
May 08 11:03	2.3	2.1	16.5	21.5	9.4	354.5
May 08 11:03	1.1	1.1	15.5	21.5	9.4	332.0
May 08 11:03	0.9	0.8	15.8	21.5	9.4	596.5
May 08 11:03	2.2	0.7	14.2	21.5	9.4	921.5
May 08 11:03	1.8	0.8	14.9	21.5	9.4	715.5
May 08 11:04	5.4	2.2	13.2	21.5	9.4	441.0
May 08 11:04	6.4	2.9	15.4	21.5	9.4	345.3
May 08 11:04	3.2	2.0	16.3	21.5	9.4	253.9
May 08 11:04	2.2	1.7	14.1	21.5	9.5	231.9
May 08 11:04	3.3	2.5	15.4	21.5	9.5	270.5
May 08 11:04	2.8	2.1	16.0	21.5	9.5	248.3
May 08 11:04	1.2	0.9	15.1	21.5	9.5	386.3
May 08 11:04	2.2	1.3	14.6	21.5	9.5	572.0

AIR INFILTRATION TESTS - RESULTS

BLDG. B - 4TH FLR.

LEGEND:

DPB denotes pres. dif (Pa) between test & lower floors  
 DPU denotes pres. dif (Pa) between test & upper floors  
 DPO denotes pres. dif (Pa) between test floor & outdoors  
 Ti denotes test floor temperature (deg.C)  
 To denotes outdoor temperature  
 BM Vel denotes bell mouth velocity (fpm)

Date / Time	DPB	DPU	DPO	Ti	To	BM Vel
	1- IN3 Pa	1- IN4 Pa	1- IN5 Pa	1- IN8 deg.C	1- IN11 deg.C	1- IN12
May 08 17:28	0.8	0.6	19.0	22.6	11.9	238.6
May 08 17:28	0.8	0.7	19.5	22.6	11.9	276.5
May 08 17:28	1.0	1.3	21.4	22.6	11.9	320.3
May 08 17:28	0.8	0.8	19.8	22.6	11.9	255.0
May 08 17:28	0.8	0.7	19.7	22.6	11.9	243.4
May 08 17:28	0.8	0.7	20.3	22.6	11.9	248.0
May 08 17:29	0.8	0.7	20.6	22.6	11.9	273.8
May 08 17:29	0.8	0.7	18.1	22.6	11.9	266.3
May 08 17:29	0.8	0.8	21.8	22.6	11.9	307.0
May 08 17:29	0.8	0.6	23.1	22.6	11.9	240.4
May 08 17:29	0.8	0.6	18.5	22.6	11.9	385.8
May 08 17:29	0.8	0.6 \$X_?	18.4	22.6	11.9	313.0
May 08 17:29	0.8	0.7	20.1	22.6	11.9	272.5
May 08 17:29	0.8	0.7	19.3	22.6	11.9	239.4
May 08 17:29	0.8	0.7	18.8	22.6	11.9	215.0
May 08 17:29	0.8	0.7	19.9	22.6	11.9	264.0
May 08 17:29	0.8	0.7	21.3	22.6	11.9	292.0
May 08 17:29	0.8	0.7	20.7	22.6	11.9	267.5
May 08 17:30	0.8	0.8	18.9	22.6	11.9	259.8
May 08 17:30	0.8	0.8	20.6	22.6	11.9	275.5
May 08 17:30	0.8	0.7	20.2	22.6	11.9	260.5
May 08 17:30	0.8	0.7	21.7	22.6	11.9	245.4
May 08 17:30	0.8	0.6	22.2	22.6	11.9	193.9
May 08 17:30	0.8	0.6	18.9	22.6	11.9	337.3
May 08 17:30	0.8	0.7	19.9	22.6	11.9	295.3
May 08 17:30	0.8	0.6	18.3	22.6	11.9	254.6
May 08 17:30	0.9	1.1	20.6	22.6	11.9	269.3
May 08 17:30	0.8	0.8	20.6	22.6	11.9	283.5
May 08 17:30	0.8	0.7	20.2	22.6	11.9	290.5
May 08 17:30	0.8	0.7	19.1	22.6	11.9	285.5
May 08 17:31	0.8	0.7	19.8	22.6	11.9	323.8
May 08 17:31	0.8	0.7	20.2	22.6	11.9	307.0
May 08 17:31	0.8	0.7	20.7	22.6	11.9	275.5
May 08 17:31	0.8	0.7	19.9	22.6	11.9	251.0
May 08 17:31	0.8	0.7	19.8	22.6	11.9	245.8
May 08 17:31	0.8	0.8	20.6	22.6	11.9	274.3
May 08 17:31	0.8	0.7	20.2	22.6	11.9	267.0
May 08 17:31	0.8	0.7	20.9	22.6	11.9	241.6
May 08 17:31	0.8	0.7	18.1	22.6	11.9	232.4
May 08 17:31	0.8	0.7	20.3	22.6	11.9	273.5
May 08 17:31	0.8	0.7	20.1	22.6	11.9	251.0
May 08 17:31	0.8	0.7	21.0	22.6	11.9	244.4
May 08 17:32	0.8	0.8	17.8	22.6	11.9	257.5
May 08 17:32	0.8	0.8	20.9	22.6	12.0	268.5
May 08 17:32	0.8	0.7	19.7	22.6	12.0	246.1
May 08 17:32	0.8	0.6	20.8	22.6	12.0	241.8
May 08 17:32	0.8	0.6	20.4	22.6	12.0	202.4
May 08 17:32	0.8	0.6	16.6	22.6	12.0	212.5
May 08 17:32	0.8	0.8	19.1	22.6	12.0	241.8
May 08 17:32	0.8	1.0	19.9	22.6	12.0	277.3

AIR INFILTRATION TESTS - RESULTS

BLDG. 'B' - 4TH FLR

LEGEND:

DPB denotes pres. dif (Pa) between test & lower floors  
 DPU denotes pres. dif (Pa) between test & upper floors  
 DPO denotes pres. dif (Pa) between test floor & outdoors  
 Ti denotes test floor temperature (deg.C)  
 To denotes outdoor temperature  
 BM Vel denotes bell mouth velocity (fpm)

Date / Time	DPB	DPU	DPO	Ti	To	BM Vel
	1- IN3 Pa	1- IN4 Pa	1- IN5 Pa	1- INB deg.C	1- IN11 deg.C	1- IN12
May 08 17:39	0.9	0.7	31.6	22.6	12.0	267.8
May 08 17:39	0.8	0.7	29.1	22.6	12.0	282.5
May 08 17:39	0.8	0.7	30.1	22.6	12.0	321.5
May 08 17:39	2.5	1.8	31.3	22.6	12.0	367.5
May 08 17:39	1.1	0.9	30.8	22.6	12.0	351.5
May 08 17:39	0.9	0.7	30.1	22.6	12.0	312.8
May 08 17:39	0.8	0.7	31.4	22.6	12.0	346.0
May 08 17:39	0.8	0.7	28.9	22.6	12.0	305.0
May 08 17:40	2.1	1.4	29.7	22.6	12.0	378.0
May 08 17:40	2.5	1.7	30.7	22.6	12.0	355.5
May 08 17:40	1.7	1.3	29.1	22.6	12.0	347.5
May 08 17:40	1.3	0.9	29.0	22.6	12.0	355.0

AIR INFILTRATION TESTS - RESULTS

BLDG 'B' - 4TH FLR.

LEGEND:

DPB denotes pres. dif (Pa) between test & lower floors  
 DPU denotes pres. dif (Pa) between test & upper floors  
 DPO denotes pres. dif (Pa) between test floor & outdoors  
 Ti denotes test floor temperature (deg.C)  
 To denotes outdoor temperature  
 BM Vel denotes bell mouth velocity (fpm)

Date / Time	DPB	DPU	DPO	Ti	To	BM Vel
	1- IN3 Pa	1- IN4 Pa	1- IN5 Pa	1- IN8 deg.C	1- IN11 deg.C	1- IN12
May 08 17:46	1.4	0.7	36.3	22.6	11.8	336.0
May 08 17:46	3.3	0.9	39.4	22.6	11.7	463.3
May 08 17:46	4.1	1.3	44.6	22.6	11.7	535.0
May 08 17:46	2.4	0.8	43.3	22.6	11.7	415.8
May 08 17:46	1.0	0.7	40.9	22.6	11.7	324.8
May 08 17:46	1.1	0.7	37.2	22.6	11.7	312.3
May 08 17:47	3.8	0.7	39.6	22.6	11.7	396.3
May 08 17:47	3.2	0.7	39.6	22.6	11.7	383.8
May 08 17:47	2.2	0.7	38.6	22.6	11.7	401.8
May 08 17:47	2.7	0.8	43.8	22.6	11.7	425.3
May 08 17:47	1.1	0.7	38.4	22.6	11.7	356.8
May 08 17:47	1.4	0.7	37.4	22.6	11.7	354.8
May 08 17:47	2.1	0.8	36.0	22.6	11.7	395.8
May 08 17:47	1.9	0.8	41.4	22.6	11.7	402.0
May 08 17:47	3.0	0.8	38.8	22.6	11.7	380.0
May 08 17:47	1.7	0.7	40.0	22.6	11.7	390.3
May 08 17:47	1.0	0.7	39.6	22.6	11.7	412.8
May 08 17:47	2.2	0.7	38.8	22.6	11.7	337.3
May 08 17:48	1.7	0.7	39.4	22.6	11.7	356.8
May 08 17:48	1.1	0.7	37.4	22.6	11.7	312.8
May 08 17:48	1.6	0.7	40.5	22.6	11.7	361.0
May 08 17:48	2.5	0.8	39.6	22.6	11.7	390.5
May 08 17:48	1.7	0.7	37.9	22.6	11.7	365.0
May 08 17:48	1.8	0.7	38.9	22.6	11.7	385.0
May 08 17:48	1.8	0.7	39.4	22.6	11.7	356.0
May 08 17:48	2.8	0.8	40.1	22.6	11.7	446.8
May 08 17:48	2.7	0.8	42.5	22.6	11.7	439.8
May 08 17:48	1.1	0.7	42.0	22.6	11.7	372.5
May 08 17:48	1.4	0.7	38.1	22.6	11.7	318.0
May 08 17:48	1.4	0.6	38.0	22.6	11.7	337.3
May 08 17:49	1.6	0.7	39.2	22.6	11.7	359.0
May 08 17:49	2.6	0.8	38.7	22.6	11.7	386.5
May 08 17:49	5.8	1.1	40.8	22.6	11.7	466.8
May 08 17:49	4.8	1.1	40.4	22.6	11.7	442.5
May 08 17:49	3.1	0.9	37.5	22.6	11.7	429.8
May 08 17:49	8.6	2.6	42.6	22.6	11.7	690.5
May 08 17:49	3.6	1.1	47.7	22.6	11.7	543.0

ANALOG MONITOR 1 -- AIR-INF



**AIR INFILTRATION TESTS - RESULTS**     BLDG. 'B' - 4TH FLOOR

**LEGEND:**                      DPB denotes pres. dif (Pa) between test & lower floors  
                                      DPU denotes pres. dif (Pa) between test & upper floors  
                                      DPO denotes pres. dif (Pa) between test floor & outdoors  
                                      Ti denotes test floor temperature (deg.C)  
                                      To denotes outdoor temperature  
                                      BM Vel denotes bell mouth velocity (fpm)

	DPB	DPU	DPO	Ti	To	BM Vel
	ANALOG MONITOR 1 -- AIR-INF					
Date / Time	1- IN3 Pa	1- IN4 Pa	1- IN5 Pa	1- IN8 deg.C	1- IN11 deg.C	1- IN12
May 08 17:53	0.8	1.3	48.5	22.6	11.7	443.8
May 08 17:53	0.8	1.0	47.3	22.6	11.7	398.8
May 08 17:54	1.7	1.9	49.2	22.6	11.7	517.5
May 08 17:54	1.8	2.1	52.9	22.6	11.7	565.0
May 08 17:54	1.1	1.8	50.1	22.6	11.7	483.0
May 08 17:54	0.9	1.9	53.3	22.6	11.7	462.5
May 08 17:54	0.8	1.3	49.8	22.6	11.7	417.0
May 08 17:54	0.8	1.6	47.2	22.6	11.7	398.5
May 08 17:54	1.5	2.4	48.4	22.6	11.7	464.0
May 08 17:54	1.5	1.7	50.7	22.6	11.7	524.5
May 08 17:54	1.0	1.3	53.4	22.6	11.7	428.0
May 08 17:54	0.8	0.7	48.1	22.6	11.7	307.5
May 08 17:54	0.8	0.7	49.0	22.6	11.7	374.8
May 08 17:54	1.1	1.8	50.5	22.6	11.7	431.5
May 08 17:55	4.0	3.7	49.5	22.6	11.7	517.0
May 08 17:55	1.9	2.0	50.3	22.6	11.7	575.5
May 08 17:55	2.7	3.0	55.9	22.6	11.7	542.5
May 08 17:55	2.5	3.1	51.7	22.6	11.7	507.0
May 08 17:55	1.1	1.1	48.1	22.6	11.7	422.0



AIR INFILTRATION TESTS - RESULTS

BLDG. 'B' - 4TH FLOOR

THE ONLY ELEVATOR UNSEEN

LEGEND:

DPB denotes pres. dif (Pa) between test & lower floors  
 DPU denotes pres. dif (Pa) between test & upper floors  
 DPO denotes pres. dif (Pa) between test floor & outdoors  
 Ti denotes test floor temperature (deg.C)  
 To denotes outdoor temperature  
 BM Vel denotes bell mouth velocity (fpm)

	DPB	DPU	DPO	Ti	To	BM Vel
ANALOG MONITOR 1 -- AIR-INF						
Date / Time	1- IN3 Pa	1- IN4 Pa	1- IN5 Pa	1- IN8 deg.C	1- IN11 deg.C	1- IN12
May 08 18:00	3.2	1.4	50.3	22.6	13.0	1083
May 08 18:00	6.0	2.5	54.2	22.6	13.0	1119
May 08 18:00	4.8	2.1	54.3	22.5	13.1	1034
May 08 18:00	4.4	2.6	46.0	22.5	13.2	884.0
May 08 18:01	5.9	1.9	51.6	22.5	13.2	1404
May 08 18:01	1.5	0.9	50.2	22.5	13.3	911.5
May 08 18:01	1.0	0.8	51.0	22.5	13.4	666.5
May 08 18:01	1.7	0.7	49.8	22.5	13.4	724.0
May 08 18:01	4.2	1.4	53.1	22.5	13.6	1104
May 08 18:01	1.6	0.9	47.4	22.5	13.6	825.5
May 08 18:01	1.7	0.9	50.3	22.5	13.8	999.0
May 08 18:01	1.1	0.8	51.7	22.5	13.9	671.5
May 08 18:01	3.5	1.3	53.8	22.5	14.0	905.0

**AIR INFILTRATION TESTS - RESULTS**

BLDG. 'B' - 4TH FLOOR  
GARBAGE CHUTE UNSEALED

**LEGEND:**

DPB denotes pres. dif (Pa) between test & lower floors  
 DPU denotes pres. dif (Pa) between test & upper floors  
 DPO denotes pres. dif (Pa) between test floor & outdoors  
 Ti denotes test floor temperature (deg.C)  
 To denotes outdoor temperature  
 BM Vel denotes bell mouth velocity (fpm)

	DPB	DPU	DPO	Ti	To	BM Vel
ANALOG MONITOR 1 -- AIR-INF						
Date / Time	1- IN3 Pa	1- IN4 Pa	1- IN5 Pa	1- IN6 deg.C	1- IN11 deg.C	1- IN12
1ay 08 18:06	3.3	1.4	54.0	22.3	14.9	1140
May 08 18:06	1.2	0.8	51.5	22.3	14.9	852.5
May 08 18:06	3.0	1.2	51.3	22.3	14.9	924.0
1ay 08 18:06	2.4	1.3	46.6	22.3	15.0	946.0
1ay 08 18:06	2.2	1.2	46.3	22.3	15.0	1178
May 08 18:06	2.3	1.1	48.3	22.3	15.0	1174
1ay 08 18:06	1.3	0.8	48.7	22.3	15.1	886.0
1ay 08 18:06	0.9	0.7	50.0	22.3	15.2	889.0
May 08 18:06	1.0	0.7	46.7	22.3	15.2	812.5
1ay 08 18:06	2.2	1.1	47.7	22.3	15.2	1148
1ay 08 18:07	1.8	1.0	49.5	22.3	15.2	1180
1ay 08 18:07	1.6	0.8	53.3	22.3	15.2	1104
1ay 08 18:07	1.0	0.7	49.5	22.3	15.2	785.5
1ay 08 18:07	1.1	0.7	45.9	22.3	15.2	917.0

**AIR INFILTRATION TESTS - RESULTS**

BLDG "B" - 4TH FLR.  
G. CHUTE & STR UNSEALED

**LEGEND:**

DPB denotes pres. dif (Pa) between test & lower floors  
 DPU denotes pres. dif (Pa) between test & upper floors  
 DPO denotes pres. dif (Pa) between test floor & outdoors  
 Ti denotes test floor temperature (deg.C)  
 To denotes outdoor temperature  
 BM Vel denotes bell mouth velocity (fpm)

	DPB	DPU	DPO	Ti	To	BM Vel
ANALOG MONITOR 1 -- AIR-INF						
Date / Time	1- IN3 Pa	1- IN4 Pa	1- IN5 Pa	1- IN8 deg.C	1- IN11 deg.C	1- IN12
May 08 18:09	1.0	0.8	49.8	22.1	15.8	1566
May 08 18:09	2.7	0.9	51.0	22.1	15.8	1683
May 08 18:10	1.2	0.8	50.1	22.1	15.9	1597
May 08 18:10	0.9	0.7	48.1	22.1	15.9	1384
May 08 18:10	1.1	0.8	49.8	22.1	16.0	1413
May 08 18:10	1.6	0.6	48.8	22.1	16.0	1493
May 08 18:10	1.7	0.9	47.8	22.1	16.0	1643
May 08 18:10	2.9	1.1	46.8	22.1	16.1	1801
May 08 18:10	6.2	2.3	51.9	22.1	16.1	2079
May 08 18:10	2.7	1.0	53.1	22.1	16.1	1825
May 08 18:10	1.3	0.8	48.7	22.0	16.1	1407
May 08 18:10	1.0	0.8	47.1	22.0	15.9	1277
May 08 18:10	1.0	0.7	47.2	22.0	15.8	1260

AIR INFILTRATION TESTS - RESULTS

BLDG. 'B' - 5TH FLOOR

LEGEND:

DPB denotes pres. dif (Pa) between test & lower floors  
 DPU denotes pres. dif (Pa) between test & upper floors  
 DPO denotes pres. dif (Pa) between test floor & outdoors  
 Ti denotes test floor temperature (deg.C)  
 To denotes outdoor temperature  
 BM Vel denotes bell mouth velocity (fpm)

	DPB	DPU	DPO	Ti	To	BM Vel
ANALOG MONITOR 1 -- AIR-INF						
Date / Time	1- IN3 Pa	1- IN4 Pa	1- IN5 Pa	1- IN6 deg.C	1- IN11 deg.C	1- IN12
May 08 14:53	1.9	2.6	18.9	22.7	11.3	286.5
May 08 14:53	1.5	1.7	19.0	22.7	11.3	316.0
May 08 14:53	1.1	1.2	19.6	22.7	11.3	297.6
May 08 14:53	1.5	1.8	20.6	22.7	11.3	368.3
May 08 14:53	3.1	3.9	22.1	22.7	11.3	366.0
May 08 14:53	1.8	3.0	22.3	22.7	11.3	342.2
May 08 14:53	1.1	1.7	20.5	22.7	11.3	305.0
May 08 14:53	0.8	0.8	22.1	22.7	11.3	317.3
May 08 14:53	0.8	0.7	19.3	22.7	11.3	263.0
May 08 14:54	0.8	1.4	21.5	22.7	11.3	315.5

AIR INFILTRATION TESTS - RESULTS

BLDG. 'B' - 5TH FLR

LEGEND:

DPB denotes pres. dif (Pa) between test & lower floors  
 DPU denotes pres. dif (Pa) between test & upper floors  
 DPO denotes pres. dif (Pa) between test floor & outdoors  
 Ti denotes test floor temperature (deg.C)  
 To denotes outdoor temperature  
 BM Vel denotes bell mouth velocity (fpm)

OL	DPB	DPU	DPO	Ti	To	BM Vel
May 08 14:44	2.4	3.0	15.7	22.6	11.3	270.8
May 08 14:44	1.3	2.4	15.7	22.6	11.3	260.8
May 08 14:44	0.9	1.3	14.6	22.6	11.3	233.0
May 08 14:44	0.6	2.1	14.9	22.6	11.3	267.5
May 08 14:44	0.6	1.2	15.9	22.6	11.3	253.1
May 08 14:44	0.8	0.7	15.3	22.6	11.3	215.8
May 08 14:44	0.8	0.7	13.3	22.6	11.3	191.9
May 08 14:45	0.9	2.7	18.0	22.6	11.3	241.5
May 08 14:45	0.6	2.0	12.6	22.6	11.3	251.6
May 08 14:45	0.8	2.0	15.3	22.6	11.3	260.8
May 08 14:45	2.0	3.1	15.0	22.6	11.3	265.8
May 08 14:45	1.3	1.7	14.7	22.6	11.3	387.6
May 08 14:45	0.9	1.0	15.9	22.6	11.3	371.5
May 08 14:45	0.8	0.9	14.3	22.6	11.3	404.5
May 08 14:45	0.8	0.7	13.2	22.6	11.3	241.3
May 08 14:45	0.8	1.0	15.8	22.6	11.3	243.1
May 08 14:45	1.6	2.4	13.6	22.6	11.3	235.6
May 08 14:45	1.0	3.0	15.4	22.6	11.3	260.3
May 08 14:45	0.9	1.2	15.8	22.6	11.3	222.0
May 08 14:46	0.8	0.7	15.6	22.6	11.3	199.5
May 08 14:46	0.8	1.0	15.6	22.6	11.3	214.6
May 08 14:46	0.8	0.8	12.6	22.6	11.3	231.3
May 08 14:46	0.8	1.4	14.8	22.6	11.3	271.5
May 08 14:46	0.8	1.2	18.1	22.6	11.3	244.5
May 08 14:46	0.8	0.7	13.0	22.6	11.2	385.8
May 08 14:46	0.8	2.1	19.8	22.6	11.2	376.8
May 08 14:46	0.8	0.9	11.3	22.6	11.2	477.8
May 08 14:46	1.4	2.7	16.5	22.6	11.2	430.8
May 08 14:46	1.1	2.3	15.1	22.6	11.2	366.0
May 08 14:46	0.8	2.3	15.0	22.6	11.2	276.0
May 08 14:46	0.8	1.4	13.7	22.6	11.2	263.0
May 08 14:47	0.8	1.3	13.7	22.6	11.2	245.1
May 08 14:47	0.8	0.9	14.0	22.6	11.2	236.5
May 08 14:47	0.8	1.0	13.6	22.6	11.2	242.8
May 08 14:47	0.8	3.5	15.8	22.6	11.2	280.8
May 08 14:47	0.8	1.0	17.3	22.6	11.2	357.8
May 08 14:47	0.9	1.9	13.7	22.6	11.2	503.5
May 08 14:47	0.9	1.4	12.8	22.6	11.2	401.8
May 08 14:47	0.8	1.6	16.9	22.6	11.2	314.8
May 08 14:47	0.8	0.8	15.0	22.6	11.2	239.1
May 08 14:47	0.8	0.7	14.4	22.6	11.2	201.3
May 08 14:47	0.8	1.0	15.7	22.6	11.2	214.5
May 08 14:47	0.8	2.3	15.1	22.6	11.2	242.1
May 08 14:48	0.8	1.2	14.5	22.6	11.2	230.3
May 08 14:48	0.8	1.3	15.5	22.6	11.2	285.8
May 08 14:48	0.8	1.2	15.5	22.6	11.2	262.3
May 08 14:48	0.8	1.1	16.1	22.6	11.2	236.6
May 08 14:48	0.8	1.0	15.6	22.6	11.2	210.6
May 08 14:48	0.7	0.8	16.0	22.6	11.2	199.5

May 08 15:03	0.8	0.7	25.3	23.0	11.4	342.0
May 08 15:03	0.8	0.7	22.9	23.0	11.4	360.0
May 08 15:03	0.8	0.7	24.3	23.0	11.4	400.8
May 08 15:03	0.8	0.7	23.8	23.0	11.4	366.3
May 08 15:03	1.0	0.7	26.3	23.0	11.4	432.3
May 08 15:03	1.1	0.7	26.5	23.0	11.4	499.5
May 08 15:03	1.2	0.7	29.2	23.0	11.4	513.5
May 08 15:03	1.4	0.8	28.6	23.0	11.4	445.8
May 08 15:03	2.0	0.7	29.5	23.0	11.4	374.8
May 08 15:04	3.0	0.7	30.3	23.0	11.4	373.8
May 08 15:04	3.3	0.7	29.3	23.0	11.4	449.3
May 08 15:04	2.9	0.7	29.8	23.0	11.4	439.3
May 08 15:04	2.6	0.7	29.2	23.0	11.4	466.3
May 08 15:04	3.0	0.7	30.6	23.0	11.4	365.0
May 08 15:04	2.9	0.7	32.3	23.0	11.4	397.8
May 08 15:04	3.9	0.7	32.5	23.0	11.4	359.3
May 08 15:04	4.0	0.7	29.3	23.0	11.4	426.5
May 08 15:04	3.7	0.7	31.3	23.0	11.4	475.0
May 08 15:04	3.7	0.7	30.9	23.0	11.4	419.3
May 08 15:04	3.4	0.7	29.3	23.0	11.4	436.5
May 08 15:04	3.3	1.8	31.9	23.0	11.4	407.5
May 08 15:05	2.2	1.8	33.6	23.0	11.4	314.8
May 08 15:05	1.8	1.9	33.2	23.0	11.4	296.0
May 08 15:05	1.9	2.7	33.5	23.0	11.4	298.0
May 08 15:05	1.6	2.9	33.6	23.0	11.4	311.3
May 08 15:05	1.9	2.6	35.8	23.0	11.4	318.5
May 08 15:05	1.9	2.7	34.2	23.0	11.4	308.3
May 08 15:05	1.8	2.4	31.7	23.1	11.4	303.3
May 08 15:05	1.7	2.9	35.3	23.1	11.4	332.8
May 08 15:05	1.9	3.2	37.4	23.1	11.4	348.5
May 08 15:05	1.6	3.6	37.7	23.1	11.4	320.8
May 08 15:05	1.5	3.2	35.6	23.1	11.4	299.0
May 08 15:05	1.9	1.8	32.8	23.1	11.4	327.3
May 08 15:06	1.6	2.8	30.3	23.1	11.4	301.3
May 08 15:06	2.0	3.3	34.3	23.1	11.4	302.0
May 08 15:06	1.8	3.6	32.0	23.1	11.4	382.5
May 08 15:06	2.3	2.7	33.0	23.1	11.4	373.5
May 08 15:06	1.7	2.3	30.4	23.1	11.4	309.3
May 08 15:06	2.4	2.2	31.6	23.1	11.4	295.8
May 08 15:06	1.8	2.9	32.9	23.1	11.4	337.5
May 08 15:06	1.4	2.8	33.8	23.1	11.4	314.8
May 08 15:06	1.8	1.1	32.4	23.1	11.4	325.5
May 08 15:06	1.8	0.8	31.6	23.1	11.4	470.0
May 08 15:06	2.0	0.7	32.2	23.1	11.4	501.3
May 08 15:06	1.6	0.7	32.4	23.1	11.4	425.5
May 08 15:07	1.6	0.7	31.8	23.1	11.4	385.5
May 08 15:07	1.6	0.7	32.4	23.1	11.4	467.8
May 08 15:07	1.8	0.7	32.8	23.1	11.4	376.8
May 08 15:07	1.8	0.7	31.7	23.1	11.4	324.8
May 08 15:07	1.8	0.7	31.9	23.1	11.4	404.0
May 08 15:07	1.9	0.7	30.8	23.1	11.4	402.0
May 08 15:07	2.0	0.7	31.7	23.1	11.4	377.3
May 08 15:07	1.8	0.7	30.2	23.1	11.4	378.0
May 08 15:07	1.7	0.7	29.1	23.1	11.4	472.3
May 08 15:07	2.2	0.9	29.5	23.1	11.4	398.5
May 08 15:07	2.3	0.7	32.7	23.2	11.4	393.3
May 08 15:07	1.8	0.7	31.8	23.2	11.4	499.5
May 08 15:08	1.9	0.7	30.7	23.2	11.4	435.8
May 08 15:08	1.8	0.7	30.4	23.2	11.4	383.8
May 08 15:08	1.5	0.7	30.8	23.2	11.4	455.8
May 08 15:08	1.6	0.8	32.9	23.2	11.4	378.5
May 08 15:08	1.6	0.7	31.1	23.2	11.4	351.8
May 08 15:08	1.8	0.7	29.8	23.2	11.4	325.3

BLDG 'B'  
5TH FLR

**AIR INFILTRATION TESTS - RESULTS**

BLDG. 'B' - 5TH FLOOR

**LEGEND:**

DPB denotes pres. dif (Pa) between test & lower floors  
 DPU denotes pres. dif (Pa) between test & upper floors  
 DPO denotes pres. dif (Pa) between test floor & outdoors  
 Ti denotes test floor temperature (deg.C)  
 To denotes outdoor temperature  
 BM Vel denotes bell mouth velocity (fpm)

**DPB            DPU            DPO            Ti            To            BM Vel**

**ANALOG MONITOR 1 -- AIR-INF**

Date / Time	1- IN3 Pa	1- IN4 Pa	1- IN5 Pa	1- IN8 deg.C	1- IN11 deg.C	1- IN12
May 08 15:24	6.2	2.0	40.8	23.3	11.6	456.0
May 08 15:24	6.1	1.6	40.9	23.3	11.6	518.5
May 08 15:24	10.3	3.4	42.7	23.3	11.6	525.5
May 08 15:24	5.4	1.9	37.9	23.3	11.6	461.5
May 08 15:24	4.1	1.7	37.8	23.3	11.6	502.3
May 08 15:24	2.0	0.8	38.8	23.3	11.6	410.3
May 08 15:24	5.0	1.2	39.5	23.3	11.6	447.2
May 08 15:25	5.9	1.0	39.3	23.3	11.6	501.8
May 08 15:25	4.5	0.9	36.1	23.3	11.6	465.3
May 08 15:25	5.2	1.7	38.0	23.3	11.6	552.0
May 08 15:25	3.7	0.9	37.3	23.3	11.6	469.3
May 08 15:25	5.5	1.3	37.3	23.3	11.6	518.0
May 08 15:25	6.3	1.8	39.1	23.3	11.6	576.0
May 08 15:25	7.1	1.8	45.3	23.3	11.6	536.0



AIR INFILTRATION TESTS - RESULTS

BLDG. 'B' - 5TH FLOOR  
THE ONLY ELEV. UNSEALED

LEGEND:

DPB denotes pres. dif (Pa) between test & lower floors  
 DPU denotes pres. dif (Pa) between test & upper floors  
 DPO denotes pres. dif (Pa) between test floor & outdoors  
 Ti denotes test floor temperature (deg.C)  
 To denotes outdoor temperature  
 BM Vel denotes bell mouth velocity (fpm)

System:  
 Panel : 1

Date / Time	DPB	DPU	DPO	Ti	To	BM Vel
	1- IN3 Pa	1- IN4 Pa	1- IN5 Pa	1- IN8 deg.C	1- IN11 deg.C	1- IN12
May 08 15:31	2.6	0.9	25.0	23.2	11.4	722.5
May 08 15:31	3.0	0.9	24.8	23.2	11.4	794.5
May 08 15:31	5.0	2.0	30.0	23.2	11.4	915.5
May 08 15:31	7.0	2.5	36.6	23.2	11.4	942.5
May 08 15:31	5.3	2.2	39.9	23.2	11.4	782.5
May 08 15:31	1.4	0.9	26.4	23.2	11.4	647.5
May 08 15:31	1.1	0.7	25.2	23.2	11.4	611.5
May 08 15:31	2.2	0.7	23.8	23.2	11.4	678.5
May 08 15:31	2.8	0.8	23.0	23.2	11.4	743.5
May 08 15:31	5.6	2.7	33.7	23.2	11.4	959.0
May 08 15:31	5.6	1.2	35.8	23.2	11.4	711.5
May 08 15:32	3.1	1.0	32.5	23.2	11.4	663.0
May 08 15:32	3.9	1.1	29.2	23.2	11.4	634.0
May 08 15:32	2.1	1.0	23.3	23.1	11.4	644.5
May 08 15:32	2.4	0.6	29.7	23.1	11.4	774.0
May 08 15:32	1.0	0.7	25.8	23.1	11.4	549.0
May 08 15:32	1.9	0.7	27.7	23.1	11.4	656.0
May 08 15:32	2.1	0.7	32.5	23.1	11.4	673.0
May 08 15:32	4.5	1.1	34.9	23.1	11.4	673.5
May 08 15:32	3.4	0.8	35.6	23.1	11.4	661.5
May 08 15:32	2.0	0.7	26.8	23.1	11.4	550.0
May 08 15:32	2.5	0.7	24.9	23.1	11.5	697.0
May 08 15:32	2.9	0.9	24.6	23.1	11.5	774.5
May 08 15:33	4.4	1.7	31.4	23.1	11.5	912.0
May 08 15:33	4.6	1.4	35.3	23.1	11.5	812.0
May 08 15:33	5.6	1.1	35.0	23.1	11.5	729.0
May 08 15:33	6.6	1.8	34.0	23.1	11.5	716.0
May 08 15:33	4.1	1.1	27.1	23.1	11.5	650.0
May 08 15:33	2.9	1.2	24.1	23.1	11.5	732.0
May 08 15:33	2.4	0.8	26.8	23.1	11.5	650.5
May 08 15:33	4.2	0.8	32.0	23.1	11.5	701.5
May 08 15:33	6.2	1.8	36.8	23.1	11.5	818.0
May 08 15:33	7.6	3.2	37.9	23.1	11.5	738.5
May 08 15:33	2.2	1.0	25.9	23.1	11.5	630.0

AIR INFILTRATION TESTS - RESULTS

BLDG. 'B' - 5TH FLR.  
ELEV. & G. CHUTE UNSEALED

LEGEND:

DPB denotes pres. dif (Pa) between test & lower floors  
 DPU denotes pres. dif (Pa) between test & upper floors  
 DPO denotes pres. dif (Pa) between test floor & outdoors  
 Ti denotes test floor temperature (deg.C)  
 To denotes outdoor temperature  
 BM Vel denotes bell mouth velocity (fpm)

Date / Time	DPB	DPU	DPO	Ti	To	BM Vel
	1- IN3 Pa	1- IN4 Pa	1- IN5 Pa	1- IN8 deg.C	1- IN11 deg.C	1- IN12
May 08 15:38	3.1	1.3	22.7	22.9	11.7	763.0
May 08 15:38	4.0	1.8	21.9	22.9	11.8	883.0
May 08 15:38	5.0	2.1	28.9	22.8	11.8	976.5
May 08 15:38	8.7	3.4	38.7	22.8	11.8	1008
May 08 15:38	9.9	4.2	36.7	22.8	11.8	790.5
May 08 15:38	2.6	1.1	25.4	22.8	11.8	689.0
May 08 15:38	2.1	0.8	23.1	22.8	11.8	725.0
May 08 15:38	3.0	1.0	25.5	22.8	11.8	841.0
May 08 15:38	4.7	1.5	33.4	22.8	11.8	935.0
May 08 15:38	7.2	1.9	38.1	22.8	11.8	833.5
May 08 15:38	4.5	1.3	29.6	22.8	11.8	672.0
May 08 15:38	2.4	1.0	25.7	22.8	11.8	690.5
May 08 15:39	2.5	0.7	24.7	22.8	11.8	721.5
May 08 15:39	3.0	0.8	26.6	22.8	11.8	852.0
May 08 15:39	2.5	0.7	31.5	22.8	11.8	849.0
May 08 15:39	3.2	0.7	31.8	22.8	11.8	724.5
May 08 15:39	1.7	0.7	31.6	22.8	11.8	764.5
May 08 15:39	2.3	0.7	30.8	22.8	11.8	761.0
May 08 15:39	1.4	0.7	29.3	22.8	11.8	755.0
May 08 15:39	0.9	0.7	30.3	22.8	11.8	762.5
May 08 15:39	1.0	0.7	30.5	22.8	11.8	755.0
May 08 15:39	1.0	0.7	29.5	22.8	11.8	751.5
May 08 15:39	1.5	0.7	31.1	22.8	11.8	797.0
May 08 15:39	1.4	0.7	29.0	22.8	11.8	719.0
May 08 15:40	1.2	0.7	28.0	22.8	11.8	736.0
May 08 15:40	1.9	0.7	29.3	22.8	11.8	788.5
May 08 15:40	2.7	0.7	28.3	22.8	11.8	909.5
May 08 15:40	2.3	0.7	28.2	22.8	11.9	895.0
May 08 15:40	1.5	0.7	30.2	22.8	11.9	842.5
May 08 15:40	1.1	0.7	31.5	22.8	11.9	772.5
May 08 15:40	9.8	3.3	33.0	22.8	11.9	838.0
May 08 15:40	3.7	1.1	32.0	22.8	11.9	877.0
May 08 15:40	3.6	0.8	30.9	22.8	11.9	807.5
May 08 15:40	2.3	0.7	29.3	22.8	11.9	835.0
May 08 15:40	2.5	0.7	30.0	22.8	11.9	882.0
May 08 15:40	1.8	0.7	29.5	22.8	11.9	862.5
May 08 15:41	1.5	0.7	30.5	22.8	11.9	913.5
May 08 15:41	1.1	0.7	29.8	22.8	11.9	859.5
May 08 15:41	1.0	0.7	30.2	22.8	11.9	853.0
May 08 15:41	1.3	0.7	30.9	22.8	11.9	827.0
May 08 15:41	1.1	0.7	29.2	22.8	11.9	785.0
May 08 15:41	1.1	0.7	29.0	22.8	11.9	830.5

**AIR INFILTRATION TESTS - RESULTS**

BLDG 'B' - 5TH FLOOR  
G. CHT. & STAIR & ELEV. OPEN

**LEGEND:**

DPB denotes pres. dif (Pa) between test & lower floors  
 DPU denotes pres. dif (Pa) between test & upper floors  
 DPO denotes pres. dif (Pa) between test floor & outdoors  
 Ti denotes test floor temperature (deg.C)  
 To denotes outdoor temperature  
 BM Vel denotes bell mouth velocity (fpm)

DPB                  DPU                  DPO                  Ti                  To                  BM Vel

Panel : 1

ANALOG MONITOR 1 -- AIR-INF

Date / Time	1- IN3 Pa	1- IN4 Pa	1- IN5 Pa	1- IN8 deg.C	1- IN11 deg.C	1- IN12
May 08 15:48	1.0	1.2	30.6	22.6	11.9	1105
May 08 15:48	1.1	1.1	29.5	22.6	11.9	1145
May 08 15:48	0.9	0.9	29.1	22.6	11.9	1172
May 08 15:48	0.9	0.9	26.8	22.6	11.9	1124
May 08 15:48	0.9	0.9	27.0	22.6	11.9	1073
May 08 15:48	1.3	1.8	30.1	22.6	11.9	1186
May 08 15:48	1.0	1.7	30.5	22.6	11.9	1199
May 08 15:48	0.9	1.3	30.5	22.6	11.9	1203
May 08 15:49	0.9	0.9	32.1	22.6	11.9	1173
May 08 15:49	0.9	1.1	30.6	22.6	11.9	1079
May 08 15:49	0.9	1.0	31.6	22.6	11.9	1192

**AIR INFILTRATION TESTS - RESULTS**

BLDG. 'C' - 5TH FLR.

**LEGEND:**

DPB denotes pres. dif (Pa) between test & lower floors  
 DPU denotes pres. dif (Pa) between test & upper floors  
 DPO denotes pres. dif (Pa) between test floor & outdoors  
 Ti denotes test floor temperature (deg.C)  
 To denotes outdoor temperature  
 BM Vel denotes bell mouth velocity (fpm)

Date / Time	DPB	DPU	DPO	Ti	To	BM Vel
	1- IN3 Pa	1- IN4 Pa	1- IN5 Pa	1- IN6 deg.C	1- IN11 deg.C	1- IN12
May 16 11:42	0.9	0.7	20.0	20.7	15.6	564.0
May 16 11:42	0.9	0.9	19.8	20.7	15.6	574.0
May 16 11:42	1.7	1.3	19.9	20.7	15.7	570.5
May 16 11:42	1.6	1.4	20.0	20.7	15.7	571.0
May 16 11:42	1.2	1.4	19.8	20.7	15.6	561.0
May 16 11:42	1.7	1.5	20.2	20.7	15.6	571.5
May 16 11:43	1.4	1.2	20.0	20.7	15.9	562.0
May 16 11:43	1.3	1.1	20.1	20.7	15.9	561.0
May 16 11:43	1.0	0.7	20.2	20.7	15.9	553.0
May 16 11:43	1.1	0.8	20.0	20.7	15.9	571.5
May 16 11:43	1.1	0.7	19.9	20.7	15.9	571.0
May 16 11:43	1.3	0.9	20.0	20.7	15.9	567.5

**AIR INFILTRATION TESTS - RESULTS**

BLDG 'C' - 5TH FLR.

**LEGEND:**

DPB denotes pres. dif (Pa) between test & lower floors  
 DPU denotes pres. dif (Pa) between test & upper floors  
 DPO denotes pres. dif (Pa) between test floor & outdoors  
 Ti denotes test floor temperature (deg.C)  
 To denotes outdoor temperature  
 BM Vel denotes bell mouth velocity (fpm)

Date / Time	DPB	DPU	DPO	Ti	To	BM Vel
	1- IN3 Pa	1- IN4 Pa	1- IN5 Pa	1- IN6 deg.C	1- IN11 deg.C	1- IN12
May 16 11:50	0.00	0.5	30.0	20.7	15.4	614.0
May 16 11:50	0.1	0.9	30.1	20.7	15.4	606.0
May 16 11:50	0.2	0.8	30.1	20.7	15.4	624.5
May 16 11:50	0.00	0.3	29.6	20.7	15.3	641.5
May 16 11:50	0.00	0.5	30.0	20.7	15.3	665.0
May 16 11:50	0.7	1.3	30.5	20.7	15.3	674.0
May 16 11:50	0.00	0.7	29.9	20.7	15.3	647.0
May 16 11:50	0.00	0.2	29.5	20.7	15.3	654.5
May 16 11:51	0.07	0.5	30.4	20.7	15.3	690.5
May 16 11:51	0.00	0.6	30.0	20.7	15.3	653.0
May 16 11:51	0.00	0.1	29.8	20.7	15.3	656.0
May 16 11:51	0.00	0.5	30.0	20.7	15.3	662.0

**AIR INFILTRATION TESTS - RESULTS**

BLDG. 'C' - 5TH FLR.

**LEGEND:**

DPB denotes pres. dif (Pa) between test & lower floors  
 DPU denotes pres. dif (Pa) between test & upper floors  
 DPO denotes pres. dif (Pa) between test floor & outdoors  
 Ti denotes test floor temperature (deg.C)  
 To denotes outdoor temperature  
 BM Vel denotes bell mouth velocity (fpm)

Date / Time	DPB	DPU	DPO	Ti	To	BM Vel
	1- IN3 Pa	1- IN4 Pa	1- IN5 Pa	1- IN6 deg.C	1- IN11 deg.C	1- IN12
y 16 11:58	0.9	1.1	40.2	20.7	15.4	809.0
ay 16 11:58	0.4	0.8	39.9	20.7	15.4	794.0
y 16 11:58	0.2	0.8	40.1	20.7	15.4	800.5
y 16 11:58	0.4	0.9	39.9	20.7	15.4	781.5
ay 16 11:59	0.06	0.5	39.8	20.7	15.3	795.5
ay 16 11:59	0.7	1.2	40.3	20.7	15.3	811.0
y 16 11:59	0.8	1.2	40.2	20.7	15.3	807.5
y 16 11:59	0.01	0.6	39.8	20.7	15.3	796.0
ay 16 11:59	0.2	0.8	40.1	20.7	15.3	789.0
y 16 11:59	1.0	1.3	40.2	20.7	15.3	791.5

AIR INFILTRATION TESTS - RESULTS

BLDG. 'C' - 5TH FLR.

LEGEND:

DPB denotes pres. dif (Pa) between test & lower floors  
 DPU denotes pres. dif (Pa) between test & upper floors  
 DPO denotes pres. dif (Pa) between test floor & outdoors  
 Ti denotes test floor temperature (deg.C)  
 To denotes outdoor temperature  
 BM Vel denotes bell mouth velocity (fpm)

Date / Time	DPB	DPU	DPO	Ti	To	BM Vel
	1- IN3 Pa	1- IN4 Pa	1- IN5 Pa	1- IN8 deg.C	1- IN11 deg.C	1- IN12
May 16 12:04	0.5	0.6	49.9	20.7	15.2	904.0
May 16 12:05	0.1	0.6	49.9	20.7	15.2	898.0
May 16 12:05	0.00	1.1	50.1	20.7	15.2	905.5
May 16 12:05	0.9	1.4	50.1	20.7	15.2	911.0
May 16 12:05	0.4	1.1	49.9	20.7	15.1	906.5
May 16 12:05	0.7	0.7	49.9	20.7	15.1	888.5
May 16 12:05	0.00	0.00	49.5	20.7	15.1	891.5
May 16 12:05	0.4	0.7	50.2	20.7	15.1	905.5
May 16 12:05	0.00	0.8	50.0	20.7	15.1	881.0
May 16 12:05	0.00	0.5	49.8	20.7	15.1	882.0
May 16 12:05	0.00	0.9	50.1	20.7	15.1	882.5
May 16 12:05	0.00	0.8	49.8	20.7	15.1	892.5
May 16 12:05	0.5	1.0	50.1	20.7	15.1	901.5
May 16 12:06	0.5	1.4	50.0	20.7	15.1	910.0



**AIR INFILTRATION TESTS - RESULTS**

BLDG 'C' - 5TH FLR.

LOWER FAN OFF.

**LEGEND:**

DPB denotes pres. dif (Pa) between test & lower floors  
 DPU denotes pres. dif (Pa) between test & upper floors  
 DPO denotes pres. dif (Pa) between test floor & outdoors  
 Ti denotes test floor temperature (deg.C)  
 To denotes outdoor temperature  
 BM Vel denotes bell mouth velocity (fpm)

Date / Time	DPB	DPU	DPO	Ti	To	BM Vel
	1- IN3 Pa	1- IN4 Pa	1- IN5 Pa	1- IN8 deg.C	1- IN11 deg.C	1- IN12
May 16 11:14	19.5	0.00	19.9	20.3	15.4	935.5
May 16 11:14	19.6	0.00	19.9	20.3	15.4	934.0
May 16 11:14	19.9	0.00	20.0	20.3	15.4	947.5
May 16 11:14	20.2	0.1	20.1	20.3	15.4	956.5
May 16 11:14	19.5	0.00	20.1	20.3	15.4	956.5
May 16 11:14	19.9	0.00	20.0	20.3	15.4	935.0
May 16 11:14	19.9	0.00	20.0	20.3	15.4	947.0
May 16 11:14	19.4	0.00	20.0	20.3	15.4	962.5
May 16 11:14	19.8	0.00	19.9	20.3	15.4	949.5
May 16 11:14	19.5	0.00	19.9	20.3	15.4	945.0
May 16 11:14	20.0	0.00	20.0	20.3	15.4	945.5

AIR INFILTRATION TESTS - RESULTS

BLDG 'C' - 5TH FLR  
LOWER FAN OFF

LEGEND:

DPB denotes pres. dif (Pa) between test & lower floors  
 DPU denotes pres. dif (Pa) between test & upper floors  
 DPO denotes pres. dif (Pa) between test floor & outdoors  
 Ti denotes test floor temperature (deg.C)  
 To denotes outdoor temperature  
 BM Vel denotes bell mouth velocity (fpm)

			DPB	DPU	DPO	Ti	To	BM Vel
			Pa	Pa	Pa	deg.C	deg.C	
May	16	11:20	28.1	0.09	30.1	20.5	15.9	1142
May	16	11:20	29.0	0.6	30.1	20.5	15.9	1162
May	16	11:20	28.1	0.00	30.0	20.5	15.9	1146
May	16	11:20	27.8	0.00	30.0	20.5	15.9	1134
May	16	11:20	28.3	0.5	29.8	20.5	15.9	1130
May	16	11:20	28.7	0.7	30.0	20.5	15.9	1160
May	16	11:21	28.1	0.3	30.2	20.5	15.9	1166
May	16	11:21	28.2	0.2	29.9	20.5	15.9	1163
May	16	11:21	28.0	0.00	30.2	20.5	15.9	1164
May	16	11:21	28.3	0.10	30.1	20.5	15.9	1133
May	16	11:21	27.9	0.00	29.9	20.5	15.9	1138
May	16	11:21	27.6	0.00	30.0	20.5	15.9	1136
May	16	11:21	27.6	0.00	30.1	20.5	15.9	1133

**AIR INFILTRATION TESTS - RESULTS**

BLDG 'C' - 5TH FLR.  
LOWER FAN OFF.

**LEGEND:**

DPB denotes pres. dif (Pa) between test & lower floors  
 DPU denotes pres. dif (Pa) between test & upper floors  
 DPO denotes pres. dif (Pa) between test floor & outdoors  
 Ti denotes test floor temperature (deg.C)  
 To denotes outdoor temperature  
 BM Vel denotes bell mouth velocity (fpm)

	DPB	DPU	DPO	Ti	To	BM Vel
	ANALOG MONITOR 1 -- AIR-INF					
Date / Time	1- IN3 Pa	1- IN4 Pa	1- IN5 Pa	1- IN6 deg.C	1- IN11 deg.C	1- IN12
May 16 11:26	44.7	1.6	39.8	20.5	16.0	1466
May 16 11:26	43.1	1.4	40.0	20.5	16.0	1476
May 16 11:26	42.0	0.9	40.1	20.5	15.9	1445
May 16 11:26	41.8	1.0	39.9	20.5	15.9	1472
May 16 11:26	41.5	1.2	39.9	20.5	15.9	1452
May 16 11:26	42.4	1.2	40.4	20.5	15.8	1472
May 16 11:26	41.7	0.9	40.3	20.5	15.8	1441
May 16 11:26	40.7	0.5	40.2	20.5	15.7	1406
May 16 11:26	41.4	1.2	39.9	20.5	15.7	1412
May 16 11:26	40.9	0.4	39.9	20.5	15.7	1455
May 16 11:26	39.0	0.2	39.8	20.5	15.6	1402
May 16 11:26	39.1	0.3	39.9	20.5	15.6	1400
May 16 11:27	39.1	0.2	39.7	20.5	15.6	1446
May 16 11:27	40.2	0.5	39.6	20.5	15.6	1469
May 16 11:27	41.6	0.7	40.3	20.5	15.6	1476

**AIR INFILTRATION TESTS - RESULTS**

**BLDG. 'B' - 5TH FLR**

**LEGEND:**

DPB denotes pres. dif (Pa) between test & lower floors  
 DPU denotes pres. dif (Pa) between test & upper floors  
 DPO denotes pres. dif (Pa) between test floor & outdoors  
 Ti denotes test floor temperature (deg.C)  
 To denotes outdoor temperature  
 BM Vel denotes bell mouth velocity (fpm)

	OL	DPB	DPU	DPO	Ti	To	BM Vel
May 08	14:44	2.4	3.0	15.7	22.6	11.3	270.8
May 08	14:44	1.3	2.4	15.7	22.6	11.3	260.8
May 08	14:44	0.9	1.3	14.6	22.6	11.3	233.0
May 08	14:44	0.8	2.1	14.9	22.6	11.3	267.5
May 08	14:44	0.8	1.2	15.9	22.6	11.3	253.1
May 08	14:44	0.8	0.7	15.3	22.6	11.3	215.8
May 08	14:44	0.8	0.7	13.3	22.6	11.3	191.9
May 08	14:45	0.9	2.7	18.0	22.6	11.3	241.5
May 08	14:45	0.8	2.0	12.8	22.6	11.3	251.6
May 08	14:45	0.8	2.0	15.3	22.6	11.3	260.8
May 08	14:45	2.0	3.1	15.0	22.6	11.3	265.8
May 08	14:45	1.3	1.7	14.7	22.6	11.3	367.6
May 08	14:45	0.9	1.0	15.9	22.6	11.3	371.5
May 08	14:45	0.8	0.9	14.3	22.6	11.3	404.5
May 08	14:45	0.8	0.7	13.2	22.6	11.3	241.3
May 08	14:45	0.8	1.0	15.8	22.6	11.3	243.1
May 08	14:45	1.6	2.4	13.8	22.6	11.3	238.8
May 08	14:45	1.0	3.0	15.4	22.6	11.3	260.8
May 08	14:45	0.8	1.2	15.8	22.6	11.3	222.0
May 08	14:46	0.8	0.7	15.8	22.6	11.3	199.5
May 08	14:46	0.8	1.0	15.8	22.6	11.3	214.8
May 08	14:46	0.8	0.8	12.6	22.6	11.3	231.3
May 08	14:46	0.8	1.4	14.8	22.6	11.3	271.8
May 08	14:46	0.8	1.2	18.1	22.6	11.3	244.5
May 08	14:46	0.8	0.7	13.0	22.6	11.2	385.8
May 08	14:46	0.8	2.1	19.8	22.6	11.2	378.8
May 08	14:46	0.8	0.9	11.3	22.6	11.2	477.8
May 08	14:46	1.4	2.7	16.5	22.6	11.2	430.8
May 08	14:46	1.1	2.3	15.1	22.6	11.2	366.0
May 08	14:46	0.8	2.3	15.0	22.6	11.2	276.0
May 08	14:46	0.8	1.4	13.7	22.6	11.2	263.0
May 08	14:47	0.8	1.3	13.7	22.6	11.2	245.1
May 08	14:47	0.8	0.9	14.0	22.6	11.2	236.5
May 08	14:47	0.8	1.0	13.6	22.6	11.2	242.8
May 08	14:47	0.8	3.5	16.8	22.6	11.2	280.8
May 08	14:47	0.8	1.0	17.3	22.6	11.2	357.8
May 08	14:47	0.9	1.9	13.7	22.6	11.2	503.5
May 08	14:47	0.9	1.4	12.8	22.6	11.2	401.8
May 08	14:47	0.8	1.6	16.9	22.6	11.2	314.8
May 08	14:47	0.8	0.8	15.0	22.6	11.2	239.1
May 08	14:47	0.8	0.7	14.4	22.6	11.2	201.3
May 08	14:47	0.8	1.0	15.7	22.6	11.2	214.5
May 08	14:47	0.8	2.3	15.1	22.6	11.2	242.1
May 08	14:48	0.8	1.2	14.5	22.6	11.2	230.3
May 08	14:48	0.8	1.3	15.5	22.6	11.2	285.8
May 08	14:48	0.8	1.2	15.5	22.6	11.2	262.3
May 08	14:48	0.8	1.1	16.1	22.6	11.2	238.8
May 08	14:48	0.8	1.0	15.6	22.6	11.2	210.8
May 08	14:48	0.7	0.8	16.0	22.6	11.2	199.5

BLDG 'B'  
5TH FLR

May 08 15:03	0.8	0.7	25.3	23.0	11.4	342.0
May 08 15:03	0.8	0.7	22.9	23.0	11.4	360.0
May 08 15:03	0.8	0.7	24.3	23.0	11.4	400.8
May 08 15:03	0.8	0.7	23.8	23.0	11.4	366.3
May 08 15:03	1.0	0.7	26.3	23.0	11.4	432.3
May 08 15:03	1.1	0.7	26.5	23.0	11.4	499.5
May 08 15:03	1.2	0.7	29.2	23.0	11.4	513.5
May 08 15:03	1.4	0.8	28.6	23.0	11.4	445.8
May 08 15:03	2.0	0.7	29.5	23.0	11.4	374.8
May 08 15:04	3.0	0.7	30.3	23.0	11.4	373.8
May 08 15:04	3.3	0.7	29.3	23.0	11.4	449.3
May 08 15:04	2.9	0.7	29.8	23.0	11.4	439.3
May 08 15:04	2.6	0.7	29.2	23.0	11.4	466.3
May 08 15:04	3.0	0.7	30.6	23.0	11.4	365.0
May 08 15:04	2.9	0.7	32.3	23.0	11.4	397.8
May 08 15:04	3.9	0.7	32.5	23.0	11.4	359.3
May 08 15:04	4.0	0.7	29.3	23.0	11.4	426.5
May 08 15:04	3.7	0.7	31.3	23.0	11.4	475.0
May 08 15:04	3.7	0.7	30.9	23.0	11.4	419.3
May 08 15:04	3.4	0.7	29.3	23.0	11.4	436.5
May 08 15:04	3.3	1.8	31.9	23.0	11.4	407.5
May 08 15:05	2.2	1.8	33.6	23.0	11.4	314.8
May 08 15:05	1.8	1.9	33.2	23.0	11.4	296.0
May 08 15:05	1.9	2.7	33.5	23.0	11.4	298.0
May 08 15:05	1.6	2.9	33.6	23.0	11.4	311.3
May 08 15:05	1.9	2.6	35.8	23.0	11.4	316.5
May 08 15:05	1.9	2.7	34.2	23.0	11.4	306.3
May 08 15:05	1.8	2.4	31.7	23.1	11.4	303.3
May 08 15:05	1.7	2.9	35.3	23.1	11.4	332.8
May 08 15:05	1.9	3.2	37.4	23.1	11.4	348.5
May 08 15:05	1.6	3.6	37.7	23.1	11.4	320.8
May 08 15:05	1.5	3.2	35.6	23.1	11.4	299.0
May 08 15:05	1.9	1.6	32.8	23.1	11.4	327.3
May 08 15:06	1.6	2.8	30.3	23.1	11.4	311.3
May 08 15:06	2.0	3.3	34.3	23.1	11.4	322.0
May 08 15:06	1.8	3.8	32.0	23.1	11.4	382.5
May 08 15:06	2.3	2.7	33.0	23.1	11.4	373.3
May 08 15:06	1.7	2.3	30.4	23.1	11.4	309.3
May 08 15:06	2.4	2.2	31.6	23.1	11.4	295.8
May 08 15:06	1.8	2.9	32.9	23.1	11.4	337.5
May 08 15:06	1.4	2.8	33.8	23.1	11.4	314.8
May 08 15:06	1.8	1.1	32.4	23.1	11.4	325.5
May 08 15:06	1.8	0.8	31.6	23.1	11.4	470.0
May 08 15:06	2.0	0.7	32.2	23.1	11.4	501.3
May 08 15:06	1.6	0.7	32.4	23.1	11.4	425.5
May 08 15:07	1.6	0.7	31.8	23.1	11.4	385.5
May 08 15:07	1.6	0.7	32.4	23.1	11.4	467.8
May 08 15:07	1.8	0.7	32.8	23.1	11.4	376.8
May 08 15:07	1.8	0.7	31.7	23.1	11.4	324.8
May 08 15:07	1.8	0.7	31.9	23.1	11.4	404.0
May 08 15:07	1.9	0.7	30.8	23.1	11.4	402.0
May 08 15:07	2.0	0.7	31.7	23.1	11.4	377.3
May 08 15:07	1.8	0.7	30.2	23.1	11.4	378.0
May 08 15:07	1.7	0.7	29.1	23.1	11.4	472.3
May 08 15:07	2.2	0.9	29.5	23.1	11.4	398.5
May 08 15:07	2.3	0.7	32.7	23.2	11.4	393.3
May 08 15:07	1.8	0.7	31.8	23.2	11.4	499.5
May 08 15:08	1.9	0.7	30.7	23.2	11.4	435.5
May 08 15:08	1.8	0.7	30.4	23.2	11.4	383.8
May 08 15:08	1.5	0.7	30.8	23.2	11.4	455.8
May 08 15:08	1.6	0.8	32.9	23.2	11.4	378.5
May 08 15:08	1.6	0.7	31.1	23.2	11.4	351.8
May 08 15:08	1.8	0.7	29.8	23.2	11.4	325.3

**AIR INFILTRATION TESTS - RESULTS**

BLDG. 'B' - 5TH FLOOR

**LEGEND:**

DPB denotes pres. dif (Pa) between test & lower floors  
 DPU denotes pres. dif (Pa) between test & upper floors  
 DPO denotes pres. dif (Pa) between test floor & outdoors  
 Ti denotes test floor temperature (deg.C)  
 To denotes outdoor temperature  
 BM Vel denotes bell mouth velocity (fpm)

	DPB	DPU	DPO	Ti	To	BM Vel
	ANALOG MONITOR 1 -- AIR-INF					
Date / Time	1- IN3 Pa	1- IN4 Pa	1- IN5 Pa	1- IN8 deg.C	1- IN11 deg.C	1- IN12
May 08 15:24	6.2	2.0	40.8	23.3	11.6	456.0
May 08 15:24	6.1	1.6	40.9	23.3	11.6	518.5
May 08 15:24	10.3	3.4	42.7	23.3	11.6	525.5
May 08 15:24	5.4	1.9	37.9	23.3	11.6	481.5
May 08 15:24	4.1	1.7	37.8	23.3	11.6	502.3
May 08 15:24	2.0	0.8	38.8	23.3	11.6	410.3
May 08 15:24	5.0	1.2	39.5	23.3	11.6	447.3
May 08 15:25	5.9	1.0	39.3	23.3	11.6	501.8
May 08 15:25	4.5	0.9	36.1	23.3	11.6	465.3
May 08 15:25	5.2	1.7	38.0	23.3	11.6	552.0
May 08 15:25	3.7	0.9	37.3	23.3	11.6	489.3
May 08 15:25	5.5	1.3	37.3	23.3	11.6	518.0
May 08 15:25	6.3	1.8	39.1	23.3	11.6	576.0
May 08 15:25	7.1	1.8	45.3	23.3	11.6	536.0

**AIR INFILTRATION TESTS - RESULTS**

BLDG. 'B' - 5TH FLOOR  
THE ONLY ELEV. UNSEALED

**LEGEND:**

DPB denotes pres. dif (Pa) between test & lower floors  
 DPU denotes pres. dif (Pa) between test & upper floors  
 DPO denotes pres. dif (Pa) between test floor & outdoors  
 TI denotes test floor temperature (deg.C)  
 To denotes outdoor temperature  
 BM Vel denotes bell mouth velocity (fpm)

System:  
 Panel : 1

Date / Time	DPB	DPU	DPO	TI	To	BM Vel
	1- IN3 Pa	1- IN4 Pa	1- IN5 Pa	1- IN8 deg.C	1- IN11 deg.C	1- IN12
May 08 15:31	2.6	0.9	25.0	23.2	11.4	722.5
May 08 15:31	3.0	0.9	24.8	23.2	11.4	794.5
May 08 15:31	5.0	2.0	30.0	23.2	11.4	915.5
May 08 15:31	7.0	2.5	36.6	23.2	11.4	942.5
May 08 15:31	5.3	2.2	39.9	23.2	11.4	782.5
May 08 15:31	1.4	0.9	26.4	23.2	11.4	647.5
May 08 15:31	1.1	0.7	25.2	23.2	11.4	611.5
May 08 15:31	2.2	0.7	23.8	23.2	11.4	678.5
May 08 15:31	2.8	0.8	23.0	23.2	11.4	743.5
May 08 15:31	5.6	2.7	33.7	23.2	11.4	959.0
May 08 15:31	5.6	1.2	35.8	23.2	11.4	711.5
May 08 15:32	3.1	1.0	32.5	23.2	11.4	663.0
May 08 15:32	3.9	1.1	29.2	23.2	11.4	634.0
May 08 15:32	2.1	1.0	23.3	23.1	11.4	644.5
May 08 15:32	2.4	0.8	29.7	23.1	11.4	774.0
May 08 15:32	1.0	0.7	25.8	23.1	11.4	549.0
May 08 15:32	1.9	0.7	27.7	23.1	11.4	656.0
May 08 15:32	2.1	0.7	32.5	23.1	11.4	673.0
May 08 15:32	4.5	1.1	34.9	23.1	11.4	673.5
May 08 15:32	3.4	0.8	35.6	23.1	11.4	661.5
May 08 15:32	2.0	0.7	26.8	23.1	11.4	550.0
May 08 15:32	2.5	0.7	24.9	23.1	11.5	697.0
May 08 15:32	2.9	0.9	24.6	23.1	11.5	774.5
May 08 15:33	4.4	1.7	31.4	23.1	11.5	912.0
May 08 15:33	4.6	1.4	35.3	23.1	11.5	812.0
May 08 15:33	5.6	1.1	35.0	23.1	11.5	729.0
May 08 15:33	6.6	1.8	34.0	23.1	11.5	716.0
May 08 15:33	4.1	1.1	27.1	23.1	11.5	650.0
May 08 15:33	2.9	1.2	24.1	23.1	11.5	732.0
May 08 15:33	2.4	0.8	26.8	23.1	11.5	650.5
May 08 15:33	4.2	0.8	32.0	23.1	11.5	701.5
May 08 15:33	6.2	1.8	36.8	23.1	11.5	818.0
May 08 15:33	7.6	3.2	37.9	23.1	11.5	738.5
May 08 15:33	2.2	1.0	25.9	23.1	11.5	630.0



**AIR INFILTRATION TESTS - RESULTS**

BLDG. 'B' - 5TH FLR.  
ELEV. & G. CHUTE UNSEAL

**LEGEND:**

DPB denotes pres. dif (Pa) between test & lower floors  
DPU denotes pres. dif (Pa) between test & upper floors  
DPO denotes pres. dif (Pa) between test floor & outdoors  
Ti denotes test floor temperature (deg.C)  
To denotes outdoor temperature  
BM Vel denotes bell mouth velocity (fpm)

Date / Time	DPB	DPU	DPO	Ti	To	BM Vel
	1- IN3 Pa	1- IN4 Pa	1- IN5 Pa	1- IN8 deg. C	1- IN11 deg. C	1- IN12
May 08 15:38	3.1	1.3	22.7	22.9	11.7	763.0
May 08 15:38	4.0	1.8	21.9	22.9	11.8	883.0
May 08 15:38	5.0	2.1	28.9	22.8	11.8	976.5
May 08 15:38	8.7	3.4	38.7	22.8	11.8	1008
May 08 15:38	9.9	4.2	36.7	22.8	11.8	790.5
May 08 15:38	2.6	1.1	26.4	22.8	11.8	689.0
May 08 15:38	2.1	0.8	23.1	22.8	11.8	725.0
May 08 15:38	3.0	1.0	25.5	22.8	11.8	841.0
May 08 15:38	4.7	1.5	33.4	22.8	11.8	935.0
May 08 15:38	7.2	1.9	38.1	22.8	11.8	833.5
May 08 15:38	4.5	1.3	29.6	22.8	11.8	672.0
May 08 15:38	2.4	1.0	25.7	22.8	11.8	690.5
May 08 15:39	2.5	0.7	24.7	22.8	11.8	721.5
May 08 15:39	3.0	0.8	26.6	22.8	11.8	852.0
May 08 15:39	2.5	0.7	31.5	22.8	11.8	849.0
May 08 15:39	3.2	0.7	31.8	22.8	11.8	724.5
May 08 15:39	1.7	0.7	31.6	22.8	11.8	764.5
May 08 15:39	2.3	0.7	30.8	22.8	11.8	761.0
May 08 15:39	1.4	0.7	29.3	22.8	11.8	755.0
May 08 15:39	0.9	0.7	30.3	22.8	11.8	762.5
May 08 15:39	1.0	0.7	30.5	22.8	11.8	755.0
May 08 15:39	1.0	0.7	29.5	22.8	11.8	751.5
May 08 15:39	1.5	0.7	31.1	22.8	11.8	797.0
May 08 15:39	1.4	0.7	29.0	22.8	11.8	719.0
May 08 15:40	1.2	0.7	28.0	22.8	11.8	736.0
May 08 15:40	1.9	0.7	29.3	22.8	11.8	788.5
May 08 15:40	2.7	0.7	28.3	22.8	11.8	909.5
May 08 15:40	2.3	0.7	28.2	22.8	11.9	895.0
May 08 15:40	1.5	0.7	30.2	22.8	11.9	842.5
May 08 15:40	1.1	0.7	31.5	22.8	11.9	772.5
May 08 15:40	9.8	3.3	33.0	22.8	11.9	838.0
May 08 15:40	3.7	1.1	32.0	22.8	11.9	877.0
May 08 15:40	3.6	0.8	30.9	22.8	11.9	807.5
May 08 15:40	2.3	0.7	29.3	22.8	11.9	835.0
May 08 15:40	2.5	0.7	30.0	22.8	11.9	882.0
May 08 15:40	1.6	0.7	29.5	22.8	11.9	862.5
May 08 15:41	1.5	0.7	30.5	22.8	11.9	913.5
May 08 15:41	1.1	0.7	29.8	22.8	11.9	859.5
May 08 15:41	1.0	0.7	30.2	22.8	11.9	853.0
May 08 15:41	1.3	0.7	30.9	22.8	11.9	827.0
May 08 15:41	1.1	0.7	29.2	22.8	11.9	765.0
May 08 15:41	1.1	0.7	29.0	22.8	11.9	830.5

**AIR INFILTRATION TESTS - RESULTS**

BLDG 'B' - 5TH FLOOR  
G. CH. & STAIR & ELEV. OPEN

**LEGEND:**

DPB denotes pres. dif (Pa) between test & lower floors  
 DPU denotes pres. dif (Pa) between test & upper floors  
 DPO denotes pres. dif (Pa) between test floor & outdoors  
 Ti denotes test floor temperature (deg.C)  
 To denotes outdoor temperature  
 BM Vel denotes bell mouth velocity (fpm)

	DPB	DPU	DPO	Ti	To	BM Vel
Panel : 1						
ANALOG MONITOR 1 -- AIR-INF						
Date / Time	1- IN3 Pa	1- IN4 Pa	1- IN5 Pa	1- IN6 deg.C	1- IN11 deg.C	1- IN12
May 08 15:48	1.0	1.2	30.6	22.6	11.9	1195
May 08 15:48	1.1	1.1	29.5	22.6	11.9	1145
May 08 15:48	0.9	0.9	29.1	22.6	11.9	1172
May 08 15:48	0.9	0.9	28.8	22.6	11.9	1124
May 08 15:48	0.9	0.9	27.0	22.6	11.9	1073
May 08 15:48	1.3	1.8	30.1	22.6	11.9	1126
May 08 15:48	1.0	1.7	30.5	22.6	11.9	1199
May 08 15:48	0.9	1.3	30.5	22.6	11.9	1203
May 08 15:49	0.9	0.9	32.1	22.6	11.9	1173
May 08 15:49	0.9	1.1	30.6	22.6	11.9	1079
May 08 15:49	0.9	1.0	31.6	22.6	11.9	1192

**AIR INFILTRATION TESTS - RESULTS**

BLDG. 'C' - 5TH FLR.

**LEGEND:**

DPB denotes pres. dif (Pa) between test & lower floors  
 DPU denotes pres. dif (Pa) between test & upper floors  
 DPO denotes pres. dif (Pa) between test floor & outdoors  
 Ti denotes test floor temperature (deg.C)  
 To denotes outdoor temperature  
 BM Vel denotes bell mouth velocity (fpm)

	DPB	DPU	DPO	Ti	To	BM Vel
Date / Time	1- IN3 Pa	1- IN4 Pa	1- IN5 Pa	1- IN6 deg.C	1- IN11 deg.C	1- IN12
May 16 11:42	0.9	0.7	20.0	20.7	15.6	564.0
May 16 11:42	0.9	0.9	19.8	20.7	15.6	574.0
May 16 11:42	1.7	1.3	19.9	20.7	15.7	590.5
May 16 11:42	1.8	1.4	20.0	20.7	15.7	581.0
May 16 11:42	1.8	1.4	19.8	20.7	15.8	601.0
May 16 11:42	1.7	1.5	20.2	20.7	15.8	611.5
May 16 11:43	1.4	1.1	20.0	20.7	15.9	581.0
May 16 11:43	1.3	1.1	20.1	20.7	15.9	571.0
May 16 11:43	1.0	0.7	20.2	20.7	15.9	558.0
May 16 11:43	1.1	0.8	20.0	20.7	15.9	561.0
May 16 11:43	1.1	0.7	19.9	20.7	15.9	571.0
May 16 11:43	1.3	0.9	20.0	20.7	15.9	587.5

**AIR INFILTRATION TESTS - RESULTS**

BLDG 'C' - 5TH FLR.

**LEGEND:**

DPB denotes pres. dif (Pa) between test & lower floors  
 DPU denotes pres. dif (Pa) between test & upper floors  
 DPO denotes pres. dif (Pa) between test floor & outdoors  
 Ti denotes test floor temperature (deg.C)  
 To denotes outdoor temperature  
 BM Vel denotes bell mouth velocity (fpm)

Date / Time	DPB	DPU	DPO	Ti	To	BM Vel
	1- IN3 Pa	1- IN4 Pa	1- IN5 Pa	1- IN8 deg.C	1- IN11 deg.C	1- IN12
May 16 11:50	0.00	0.5	30.0	20.7	15.4	614.0
May 16 11:50	0.1	0.9	30.1	20.7	15.4	606.0
May 16 11:50	0.2	0.8	30.1	20.7	15.4	624.5
May 16 11:50	0.00	0.3	29.6	20.7	15.3	641.5
May 16 11:50	0.00	0.5	30.0	20.7	15.3	665.0
May 16 11:50	0.7	1.3	30.5	20.7	15.3	674.0
May 16 11:50	0.00	0.7	29.9	20.7	15.3	647.0
May 16 11:50	0.00	0.2	29.5	20.7	15.3	654.5
May 16 11:51	0.07	0.5	30.4	20.7	15.3	690.5
May 16 11:51	0.00	0.6	30.0	20.7	15.3	653.0
May 16 11:51	0.00	0.1	29.8	20.7	15.3	656.0
May 16 11:51	0.00	0.5	30.0	20.7	15.3	662.0

AIR INFILTRATION TESTS - RESULTS

Bldg. 'C' - 5TH FLR.

LEGEND:

DPB denotes pres. dif (Pa) between test & lower floors  
 DPU denotes pres. dif (Pa) between test & upper floors  
 DPO denotes pres. dif (Pa) between test floor & outdoors  
 Ti denotes test floor temperature (deg.C)  
 To denotes outdoor temperature  
 BM Vel denotes bell mouth velocity (fpm)

Date / Time	DPB	DPU	DPO	Ti	To	BM Vel
	1- IN3 Pa	1- IN4 Pa	1- IN5 Pa	1- IN8 deg.C	1- IN11 deg.C	1- IN12
y 16 11:58	0.9	1.1	40.2	20.7	15.4	809.0
ay 16 11:58	0.4	0.8	39.9	20.7	15.4	794.0
ay 16 11:58	0.2	0.8	40.1	20.7	15.4	800.5
y 16 11:58	0.4	0.9	39.9	20.7	15.4	781.5
ay 16 11:59	0.06	0.5	39.8	20.7	15.3	795.5
ay 16 11:59	0.7	1.2	40.3	20.7	15.3	811.0
y 16 11:59	0.8	1.2	40.2	20.7	15.3	807.5
ay 16 11:59	0.01	0.6	39.8	20.7	15.3	796.0
ay 16 11:59	0.2	0.8	40.1	20.7	15.3	789.0
y 16 11:59	1.0	1.3	40.2	20.7	15.3	791.5

AIR INFILTRATION TESTS - RESULTS

BLDG. 'C' - 5TH FLR.

LEGEND:

DPB denotes pres. dif (Pa) between test & lower floors  
 DPU denotes pres. dif (Pa) between test & upper floors  
 DPO denotes pres. dif (Pa) between test floor & outdoors  
 Ti denotes test floor temperature (deg.C)  
 To denotes outdoor temperature  
 BM Vel denotes bell mouth velocity (fpm)

Date / Time	DPB	DPU	DPO	Ti	To	BM Vel
	1- IN3 Pa	1- IN4 Pa	1- IN5 Pa	1- IN8 deg.C	1- IN11 deg.C	1- IN12
May 16 12:04	0.5	0.6	49.9	20.7	15.2	904.0
May 16 12:05	0.1	0.6	49.9	20.7	15.2	898.0
May 16 12:05	0.00	1.1	50.1	20.7	15.2	905.5
May 16 12:05	0.9	1.4	50.1	20.7	15.2	911.0
May 16 12:05	0.4	1.1	49.9	20.7	15.1	906.5
May 16 12:05	0.7	0.7	49.9	20.7	15.1	888.5
May 16 12:05	0.00	0.00	49.5	20.7	15.1	891.5
May 16 12:05	0.4	0.7	50.2	20.7	15.1	905.5
May 16 12:05	0.00	0.8	50.0	20.7	15.1	881.0
May 16 12:05	0.00	0.5	49.8	20.7	15.1	882.0
May 16 12:05	0.00	0.9	50.1	20.7	15.1	882.5
May 16 12:05	0.00	0.8	49.8	20.7	15.1	892.5
May 16 12:05	0.5	1.0	50.1	20.7	15.1	901.5
May 16 12:06	0.5	1.4	50.0	20.7	15.1	910.0

**AIR INFILTRATION TESTS - RESULTS**

BLDG 'C' - 5TH FLR

LOWER FAN OFF.

**LEGEND:**

DPB denotes pres. dif (Pa) between test & lower floors  
 DPU denotes pres. dif (Pa) between test & upper floors  
 DPO denotes pres. dif (Pa) between test floor & outdoors  
 Ti denotes test floor temperature (deg.C)  
 To denotes outdoor temperature  
 BM Vel denotes bell mouth velocity (fpm)

Date / Time	DPB	DPU	DPO	Ti	To	BM Vel
	1- IN3 Pa	1- IN4 Pa	1- IN5 Pa	1- IN8 deg.C	1- IN11 deg.C	1- IN12
May 16 11:14	19.5	0.00	19.9	20.3	15.4	935.5
May 16 11:14	19.6	0.00	19.9	20.3	15.4	934.0
May 16 11:14	19.9	0.00	20.0	20.3	15.4	947.5
May 16 11:14	20.2	0.1	20.1	20.3	15.4	956.5
May 16 11:14	19.5	0.00	20.1	20.3	15.4	956.5
May 16 11:14	19.9	0.00	20.0	20.3	15.4	935.0
May 16 11:14	19.9	0.00	20.0	20.3	15.4	947.0
May 16 11:14	19.4	0.00	20.0	20.3	15.4	962.5
May 16 11:14	19.8	0.00	19.9	20.3	15.4	949.5
May 16 11:14	19.5	0.00	19.9	20.3	15.4	945.0
May 16 11:14	20.0	0.00	20.0	20.3	15.4	945.5



## AIR INFILTRATION TESTS - RESULTS

BLDG 'C' - 5TH FLR

LOWER FAU OFF

## LEGEND:

DPB denotes pres. dif (Pa) between test & lower floors  
 DPU denotes pres. dif (Pa) between test & upper floors  
 DPO denotes pres. dif (Pa) between test floor & outdoors  
 Ti denotes test floor temperature (deg.C)  
 To denotes outdoor temperature  
 BM Vel denotes bell mouth velocity (fpm)

		DPB	DPU	DPO	Ti	To	BM Vel
		Pa	Pa	Pa	deg.C	deg.C	
May	16 11:20	28.1	0.09	30.1	20.5	15.9	1142
May	16 11:20	29.0	0.6	30.1	20.5	15.9	1162
May	16 11:20	28.1	0.00	30.0	20.5	15.9	1146
May	16 11:20	27.8	0.00	30.0	20.5	15.9	1134
May	16 11:20	28.3	0.5	29.8	20.5	15.9	1150
May	16 11:20	28.7	0.7	30.0	20.5	15.9	1160
May	16 11:21	28.1	0.3	30.2	20.5	15.9	1166
May	16 11:21	28.2	0.2	29.9	20.5	15.9	1163
May	16 11:21	28.0	0.00	30.2	20.5	15.9	1154
May	16 11:21	28.3	0.10	30.1	20.5	15.9	1133
May	16 11:21	27.9	0.00	29.9	20.5	15.9	1136
May	16 11:21	27.6	0.00	30.0	20.5	15.9	1136
May	16 11:21	27.6	0.00	30.1	20.5	15.9	1133

**AIR INFILTRATION TESTS - RESULTS**

BLDG 'C' - 5TH FLR.  
LOWER FAN OFF.

**LEGEND:**

DPB denotes pres. dif (Pa) between test & lower floors  
 DPU denotes pres. dif (Pa) between test & upper floors  
 DPO denotes pres. dif (Pa) between test floor & outdoors  
 Ti denotes test floor temperature (deg.C)  
 To denotes outdoor temperature  
 BM Vel denotes bell mouth velocity (fpm)

Date / Time	DPB	DPU	DPO	Ti	To	BM Vel
	ANALOG MONITOR 1 -- AIR-INF					
	1- IN3 Pa	1- IN4 Pa	1- IN5 Pa	1- IN6 deg.C	1- IN11 deg.C	1- IN12
May 16 11:26	44.7	1.6	39.8	20.5	16.0	1466
May 16 11:26	43.1	1.4	40.0	20.5	16.0	1476
May 16 11:26	42.0	0.9	40.1	20.5	15.9	1445
May 16 11:26	41.8	1.0	39.9	20.5	15.9	1472
May 16 11:26	41.5	1.2	39.9	20.5	15.9	1492
May 16 11:26	42.4	1.2	40.4	20.5	15.8	1470
May 16 11:26	41.7	0.9	40.3	20.5	15.9	1461
May 16 11:26	40.7	0.5	40.2	20.5	15.7	1466
May 16 11:26	41.4	1.2	39.9	20.5	15.7	1412
May 16 11:26	40.9	0.4	39.9	20.5	15.7	1456
May 16 11:26	39.0	0.2	39.8	20.5	15.6	1402
May 16 11:26	39.1	0.3	39.9	20.5	15.6	1400
May 16 11:27	39.1	0.2	39.7	20.5	15.6	1446
May 16 11:27	40.2	0.5	39.6	20.5	15.6	1469
May 16 11:27	41.6	0.7	40.3	20.5	15.6	1476

AIR INFILTRATION TESTS - RESULTS

BLDG 'C' - 5TH FLR.  
LOWER FAN OFF.

LEGEND:

DPB denotes pres. dif (Pa) between test & lower floors  
 DPU denotes pres. dif (Pa) between test & upper floors  
 DPO denotes pres. dif (Pa) between test floor & outdoors  
 Ti denotes test floor temperature (deg.C)  
 To denotes outdoor temperature  
 BM Vel denotes bell mouth velocity (fpm)

	DPB	DPU	DPO	Ti	To	BM Vel
ANALOG MONITOR 1 -- AIR-INF						
Date / Time	1- IN3 Pa	1- IN4 Pa	1- IN5 Pa	1- IN8 deg.C	1- IN11 deg.C	1- IN12
May 16 11:34	49.0	1.6	50.1	20.6	15.9	1615
May 16 11:34	49.6	1.1	50.2	20.6	15.9	1619
May 16 11:34	49.9	0.6	50.2	20.6	15.9	1615
May 16 11:34	48.6	0.7	49.9	20.6	15.9	1612
May 16 11:34	48.1	0.7	49.7	20.6	15.9	1630
May 16 11:34	48.2	0.7	49.9	20.6	15.9	1641
May 16 11:34	48.9	1.3	50.1	20.6	15.9	1632
May 16 11:34	48.7	1.5	49.9	20.6	15.9	1637
May 16 11:34	48.4	1.3	49.7	20.6	15.9	1642
May 16 11:35	48.5	0.7	49.9	20.6	15.9	1612
May 16 11:35	49.2	1.6	50.1	20.6	15.9	1630

AIR INFILTRATION TESTS - RESULTS

BLDG. 'C' - 5TH FLR.  
ELEV. UNSEALED.

LEGEND:

DPB denotes pres. dif (Pa) between test & lower floors  
 DPU denotes pres. dif (Pa) between test & upper floors  
 DPO denotes pres. dif (Pa) between test floor & outdoors  
 Ti denotes test floor temperature (deg.C)  
 To denotes outdoor temperature  
 BM Vel denotes bell mouth velocity (fpm)

Date / Time	DPB	DPU	DPO	Ti	To	BM Vel
	1- IN3 Pa	1- IN4 Pa	1- IN5 Pa	1- IN6 deg.C	1- IN11 deg.C	1- IN12
May 16 12:12	1.3	0.7	50.2	20.7	15.4	2132
May 16 12:12	0.5	0.8	50.0	20.7	15.4	2112
May 16 12:12	0.2	0.5	50.0	20.7	15.4	2030
May 16 12:12	1.1	0.3	49.6	20.7	15.4	2070
May 16 12:12	1.5	0.7	50.0	20.7	15.4	2102
May 16 12:12	1.3	0.6	50.1	20.7	15.4	2078
May 16 12:12	0.5	0.3	50.1	20.7	15.4	2040
May 16 12:12	0.1	0.00	50.1	20.7	15.4	2032
May 16 12:12	0.00	0.4	49.9	20.7	15.4	2031

**AIR INFILTRATION TESTS - RESULTS**

BLDG C - 5TH FLR.  
ELEV. 3 STR, UNSEALED

**LEGEND:**

DPB denotes pres. dif (Pa) between test & lower floors  
 DPU denotes pres. dif (Pa) between test & upper floors  
 DPO denotes pres. dif (Pa) between test floor & outdoors  
 Ti denotes test floor temperature (deg.C)  
 To denotes outdoor temperature  
 BM Vel denotes bell mouth velocity (fpm)

Date / Time	DPB	DPU	DPO	Ti	To	BM Vel
	1- IN3 Pa	1- IN4 Pa	1- IN5 Pa	1- IN8 deg.C	1- IN11 deg.C	1- IN12
May 16 12:16	1.4	1.4	50.0	20.5	15.6	2494
May 16 12:16	0.4	0.7	50.0	20.5	15.7	2398
May 16 12:16	0.2	0.7	50.0	20.5	15.7	2430
May 16 12:16	1.7	1.0	50.1	20.5	15.7	2458
May 16 12:16	0.9	0.6	49.7	20.5	15.8	2480
May 16 12:16	1.0	0.5	50.0	20.5	15.8	2468
May 16 12:16	1.0	0.6	50.3	20.5	15.8	2478
May 16 12:16	1.5	0.9	49.8	20.5	15.8	2434
May 16 12:17	1.8	1.3	50.0	20.5	15.8	2450
May 16 12:17	2.1	1.4	50.2	20.5	15.8	2432

**AIR INFILTRATION TESTS - RESULTS**

BLDG 'C' - 5TH FLR

ELEV. STR. ↑ FIREPL'S UNSE

**LEGEND:**

DPB denotes pres. dif (Pa) between test & lower floors  
 DPU denotes pres. dif (Pa) between test & upper floors  
 DPO denotes pres. dif (Pa) between test floor & outdoors  
 Ti denotes test floor temperature (deg.C)  
 To denotes outdoor temperature  
 BM Vel denotes bell mouth velocity (fpm)

Date / Time	DPB	DPU	DPO	Ti	To	BM Vel
	1- IN3 Pa	1- IN4 Pa	1- IN5 Pa	1- IN8 deg.C	1- IN11 deg.C	1- IN12
May 16 12:21	0.5	1.1	50.1	20.4	15.6	2402
May 16 12:22	1.6	1.0	49.6	20.4	15.6	2436
May 16 12:22	3.0	1.8	49.6	20.4	15.6	2474
May 16 12:22	2.9	1.9	49.3	20.4	15.6	2502
May 16 12:22	3.2	2.7	50.7	20.4	15.6	2582
May 16 12:22	1.7	1.6	50.1	20.4	15.6	2470
May 16 12:22	2.3	1.7	50.1	20.4	15.6	2440
May 16 12:22	2.3	1.5	49.7	20.4	15.7	2470
May 16 12:22	2.3	2.1	50.2	20.4	15.7	2476
May 16 12:22	2.4	1.4	49.8	20.4	15.7	2474
May 16 12:22	2.5	1.6	50.0	20.4	15.7	2526
May 16 12:22	1.7	1.7	50.3	20.4	15.7	2472
May 16 12:22	1.3	1.3	50.1	20.4	15.7	2452
May 16 12:23	1.3	1.2	50.0	20.4	15.7	2460
May 16 12:23	0.7	1.0	50.0	20.4	15.7	2394
May 16 12:23	2.0	1.2	50.1	20.4	15.7	2448
May 16 12:23	1.8	1.3	50.1	20.4	15.7	2472
May 16 12:23	1.2	1.1	49.9	20.4	15.7	2466
May 16 12:23	1.5	1.3	49.9	20.4	15.7	2472
May 16 12:23	1.1	1.1	50.0	20.4	15.7	2472
May 16 12:23	1.1	1.1	50.2	20.4	15.7	2516
May 16 12:23	1.8	0.9	49.8	20.4	15.7	2482
May 16 12:23	2.4	1.4	49.8	20.4	15.7	2466
May 16 12:23	1.9	1.4	49.8	20.4	15.7	2438
May 16 12:23	2.6	1.5	50.0	20.4	15.7	2434
May 16 12:24	1.8	1.8	50.6	20.4	15.7	2486
May 16 12:24	0.2	0.8	50.0	20.4	15.7	2408
May 16 12:24	0.6	1.5	49.8	20.4	15.7	2412
May 16 12:24	0.6	1.6	49.9	20.4	15.7	2422
May 16 12:24	0.3	1.6	49.9	20.4	15.7	2470
May 16 12:24	0.5	1.7	50.2	20.4	15.7	2458
May 16 12:24	0.9	1.6	50.1	20.4	15.6	2462

AIR INFILTRATION TESTS - RESULTS

BLDG. 'C' - 6TH FLR.

LEGEND:

DPB denotes pres. dif (Pa) between test & lower floors  
 DPU denotes pres. dif (Pa) between test & upper floors  
 DPO denotes pres. dif (Pa) between test floor & outdoors  
 Ti denotes test floor temperature (deg.C)  
 To denotes outdoor temperature  
 BM Vel denotes bell mouth velocity (fpm)

		DPB	DPU	DPO	Ti	To	BM Vel
May 16 16:32	0.3	0.1	20.0	21.3	15.9	243.3	
May 16 16:32	0.00	0.00	20.1	21.3	15.9	240.4	
May 16 16:32	0.4	0.3	20.3	21.3	15.9	220.3	
May 16 16:33	0.00	0.00	19.2	21.3	15.9	238.6	
May 16 16:33	1.1	1.0	20.3	21.3	15.9	258.3	
May 16 16:33	0.00	0.05	20.4	21.3	15.9	261.8	
May 16 16:33	0.03	0.05	19.4	21.3	15.9	230.5	
May 16 16:33	0.9	0.7	20.1	21.3	15.9	232.3	
May 16 16:33	0.4	0.1	19.9	21.3	15.9	229.3	
May 16 16:33	0.3	0.03	19.9	21.3	15.9	224.6	
May 16 16:33	0.4	0.1	20.2	21.3	15.9	220.5	
May 16 16:33	0.00	0.00	19.6	21.3	15.9	226.8	
May 16 16:33	1.0	0.8	20.2	21.3	15.9	255.3	
May 16 16:33	0.7	0.6	20.0	21.3	15.9	245.8	
May 16 16:33	0.3	0.4	20.0	21.3	15.9	241.8	
May 16 16:34	0.00	0.00	20.8	21.3	15.9	248.0	
May 16 16:34	0.00	0.00	19.6	21.3	15.9	210.8	
May 16 16:34	0.00	0.00	19.4	21.3	15.9	204.9	
May 16 16:34	0.5	0.4	19.9	21.3	15.9	222.0	
May 16 16:34	0.5	0.4	20.3	21.3	15.9	241.8	
May 16 16:34	0.3	0.2	20.0	21.3	15.9	245.8	
May 16 16:34	0.2	0.00	20.2	21.3	15.9	255.8	
May 16 16:34	0.4	0.3	19.8	21.3	15.9	251.1	
May 16 16:34	0.4	0.4	20.0	21.3	15.9	256.5	
May 16 16:34	0.3	0.1	20.1	21.3	15.9	261.8	
May 16 16:34	0.2	0.2	19.9	21.3	15.9	237.3	
May 16 16:34	0.5	0.5	20.0	21.3	15.9	235.9	
May 16 16:35	0.9	0.7	20.0	21.3	15.9	247.6	
May 16 16:35	1.0	0.9	19.7	21.3	15.9	247.0	
May 16 16:35	0.6	0.5	19.9	21.3	15.9	259.8	
May 16 16:35	0.6	0.6	20.2	21.3	15.9	259.5	
May 16 16:35	0.00	0.00	19.8	21.3	15.9	258.5	
May 16 16:35	0.4	0.5	20.0	21.3	15.9	243.0	
May 16 16:35	0.7	0.6	20.4	21.3	15.9	249.5	
May 16 16:35	0.00	0.05	19.7	21.3	15.9	235.9	
May 16 16:35	0.6	0.6	20.7	21.3	15.9	247.8	
May 16 16:35	0.00	0.00	19.9	21.3	15.9	240.4	
May 16 16:35	0.3	0.2	20.0	21.3	15.9	253.1	
May 16 16:35	0.00	0.00	20.4	21.3	15.9	244.1	
May 16 16:36	0.7	0.7	20.1	21.3	15.9	226.0	
May 16 16:36	0.8	0.7	19.9	21.3	15.9	246.3	
May 16 16:36	0.5	0.4	20.4	21.3	15.9	252.6	
May 16 16:36	0.3	0.2	19.7	21.3	15.9	243.1	
May 16 16:36	0.3	0.4	20.2	21.3	15.9	250.1	
May 16 16:36	0.00	0.04	20.2	21.3	15.9	242.9	
May 16 16:36	0.00	0.1	19.8	21.3	15.9	245.1	
May 16 16:36	0.9	0.9	20.6	21.3	15.9	253.9	
May 16 16:36	0.00	0.00	19.4	21.3	15.9	241.0	
May 16 16:36	0.9	0.9	20.1	21.3	15.9	255.3	
May 16 16:36	0.03	0.2	19.5	21.3	15.9	246.4	
May 16 16:36	0.7	0.7	19.9	21.3	15.9	244.4	

**AIR INFILTRATION TESTS - RESULTS**

BLDG. 'C' - 6TH FLR

**LEGEND:**

DPB denotes pres. dif (Pa) between test & lower floors  
 DPU denotes pres. dif (Pa) between test & upper floors  
 DPO denotes pres. dif (Pa) between test floor & outdoors  
 Ti denotes test floor temperature (deg.C)  
 To denotes outdoor temperature  
 BM Vel denotes bell mouth velocity (fpm)

Date / Time	DPB	DPU	DPO	Ti	To	BM Vel
	1- IN3 Pa	1- IN4 Pa	1- IN5 Pa	1- IN8 deg.C	1- IN11 deg.C	1- IN12
May 16 16:41	0.9	1.3	30.1	21.3	15.8	251.6
May 16 16:42	0.8	1.0	30.1	21.3	15.8	252.0
May 16 16:42	1.5	1.8	30.9	21.3	15.8	266.0
May 16 16:42	0.5	1.1	30.1	21.3	15.8	262.6
May 16 16:42	0.7	1.2	30.0	21.3	15.8	273.2
May 16 16:42	0.00	0.4	29.9	21.3	15.8	267.8
May 16 16:42	0.10	0.6	30.6	21.3	15.8	264.0
May 16 16:42	0.2	0.4	30.1	21.3	15.8	243.6



AIR INFILTRATION TESTS - RESULTS

BLDG. 'C' - 6<sup>TH</sup> FLR.

LEGEND:

DPB denotes pres. dif (Pa) between test & lower floors  
 DPU denotes pres. dif (Pa) between test & upper floors  
 DPO denotes pres. dif (Pa) between test floor & outdoors  
 Ti denotes test floor temperature (deg.C)  
 To denotes outdoor temperature  
 BM Vel denotes bell mouth velocity (fpm)

		DPB	DPU	DPO	Ti	To	BM Vel
May 16 16:47		1.2	0.00	39.3	21.3	15.8	281.5
May 16 16:47		1.3	0.00	39.2	21.3	15.8	269.8
May 16 16:47		1.6	0.00	39.2	21.3	15.8	272.3
May 16 16:47		1.5	0.00	39.6	21.3	15.8	272.8
May 16 16:47		1.0	0.00	39.4	21.3	15.8	287.3
May 16 16:47		0.5	0.00	39.1	21.3	15.8	291.0
May 16 16:47		2.0	0.00	40.6	21.3	15.8	289.5
May 16 16:47		1.7	0.00	40.6	21.3	15.8	310.3
May 16 16:47		1.2	0.00	40.0	21.3	15.8	306.3
May 16 16:47		2.1	0.00	40.0	21.3	15.8	281.8
May 16 16:48		1.7	0.00	39.7	21.3	15.8	267.5
May 16 16:48		2.8	0.00	40.4	21.3	15.8	270.0
May 16 16:48		1.5	0.00	40.0	21.3	15.8	261.5
May 16 16:48		2.8	0.00	41.3	21.3	15.8	294.8
May 16 16:48		1.6	0.00	40.4	21.3	15.8	315.3
May 16 16:48		2.1	0.00	40.2	21.3	15.8	318.3
May 16 16:48		2.4	0.00	40.0	21.3	15.8	339.3
May 16 16:48		1.9	0.00	39.5	21.3	15.8	294.5
May 16 16:48		1.7	0.00	39.7	21.3	15.8	278.0
May 16 16:48		2.0	0.0	40.3	21.3	15.8	303.0
May 16 16:48		2.7	4.5	39.9	21.3	15.8	375.5
May 16 16:48		2.2	3.8	40.3	21.3	15.8	403.5
May 16 16:49		2.0	3.7	41.4	21.3	15.8	410.5
May 16 16:49		2.3	4.3	40.2	21.3	15.8	391.3
May 16 16:49		2.5	4.6	40.2	21.3	15.8	444.5
May 16 16:49		1.9	3.8	39.6	21.3	15.8	392.5
May 16 16:49		2.4	4.1	39.9	21.3	15.8	403.8
May 16 16:49		2.1	3.8	39.9	21.3	15.8	393.0
May 16 16:49		1.8	3.8	39.5	21.3	15.8	386.3
May 16 16:49		1.7	3.9	40.2	21.3	15.8	418.0
May 16 16:49		1.5	3.4	39.7	21.3	15.8	405.8
May 16 16:49		2.3	4.1	39.5	21.3	15.8	399.3
May 16 16:49		3.0	4.5	40.2	21.3	15.8	420.0
May 16 16:49		3.3	4.8	39.8	21.3	15.8	412.3
May 16 16:50		2.6	4.9	39.9	21.3	15.8	450.3
May 16 16:50		2.2	4.7	39.9	21.3	15.8	446.3
May 16 16:50		2.3	4.5	40.4	21.3	15.8	468.5
May 16 16:50		1.4	3.2	40.3	21.3	15.8	436.5
May 16 16:50		2.0	3.2	40.0	21.3	15.8	391.0
May 16 16:50		3.0	4.1	40.2	21.3	15.8	400.5
May 16 16:50		3.1	4.8	39.8	21.3	15.8	421.8
May 16 16:50		3.4	5.3	40.8	21.3	15.8	466.5
May 16 16:50		2.7	4.0	39.9	21.3	15.8	454.0
May 16 16:50		2.9	4.5	39.5	21.3	15.8	429.0
May 16 16:50		4.2	5.7	40.2	21.3	15.8	470.5
May 16 16:50		3.6	5.2	40.1	21.3	15.8	474.5
May 16 16:51		2.8	4.5	40.3	21.3	15.8	470.5
May 16 16:51		3.1	4.6	40.2	21.3	15.8	450.5
May 16 16:51		2.9	4.2	40.0	21.3	15.8	438.0
May 16 16:51		2.6	3.9	40.3	21.3	15.8	435.5
May 16 16:51		2.7	4.2	40.0	21.3	15.8	415.0

AIR INFILTRATION TESTS - RESULTS

BLDG 'C' - 6TH FLR

LEGEND:

DPB denotes pres. dif (Pa) between test & lower floors  
 DPU denotes pres. dif (Pa) between test & upper floors  
 DPO denotes pres. dif (Pa) between test floor & outdoors  
 Ti denotes test floor temperature (deg.C)  
 To denotes outdoor temperature  
 BM Vel denotes bell mouth velocity (fpm)

	DPB	DPU	DPO	Ti	To	BM Vel
May 16 16:57	0.00	0.7	49.8	21.3	15.6	278.0
May 16 16:57	0.00	1.1	49.8	21.3	15.6	283.3
May 16 16:57	0.3	2.4	49.8	21.3	15.6	347.3
May 16 16:57	0.9	2.3	50.8	21.3	15.6	363.3
May 16 16:57	1.3	2.3	50.9	21.3	15.6	403.3
May 16 16:57	2.7	2.7	51.3	21.3	15.6	413.3
May 16 16:57	2.4	2.7	50.8	21.3	15.6	396.3
May 16 16:57	0.03	1.6	50.4	21.3	15.6	356.5
May 16 16:58	0.00	0.5	49.9	21.3	15.6	312.3
May 16 16:58	1.0	2.4	50.7	21.3	15.6	346.3
May 16 16:58	1.1	2.4	50.6	21.3	15.6	327.5
May 16 16:58	0.00	1.4	49.9	21.3	15.6	324.3
May 16 16:58	0.00	0.00	49.1	21.3	15.6	360.3
May 16 16:58	0.00	0.00	48.6	21.3	15.6	364.0
May 16 16:58	0.00	0.00	48.8	21.3	15.6	369.8
May 16 16:58	0.00	0.6	49.0	21.3	15.6	356.5
May 16 16:58	0.4	1.1	49.4	21.3	15.6	370.6
May 16 16:58	0.00	1.1	49.1	21.3	15.6	369.5
May 16 16:58	0.00	0.7	48.7	21.3	15.6	366.3
May 16 16:58	0.00	1.2	49.7	21.3	15.6	364.5
May 16 16:59	0.04	1.7	50.3	21.3	15.6	326.1
May 16 16:59	0.00	1.7	50.0	21.3	15.6	311.3
May 16 16:59	0.6	2.1	50.7	21.3	15.6	292.3
May 16 16:59	0.00	0.9	49.8	21.3	15.6	300.6
May 16 16:59	0.00	1.0	49.1	21.3	15.6	318.0
May 16 16:59	0.00	0.6	49.8	21.3	15.6	363.0
May 16 16:59	0.00	0.00	48.4	21.3	15.6	340.0
May 16 16:59	0.00	0.00	49.1	21.3	15.6	385.6
May 16 16:59	0.00	0.5	48.6	21.3	15.6	381.3

AIR INFILTRATION TESTS - RESULTS

BLDG. 'C' - 6TH FLR.  
LOWER FAN OFF.

LEGEND:

DPB denotes pres. dif (Pa) between test & lower floors  
 DPU denotes pres. dif (Pa) between test & upper floors  
 DPO denotes pres. dif (Pa) between test floor & outdoors  
 Ti denotes test floor temperature (deg.C)  
 To denotes outdoor temperature  
 BM Vel denotes bell mouth velocity (fpm)

		DPB	DPU	DPO	Ti	To	BM Vel
May 16	17:05	42.6	0.1	49.4	21.3	15.6	1041
May 16	17:05	42.3	0.00	49.3	21.3	15.6	1043
May 16	17:05	42.3	0.00	49.5	21.3	15.6	1069
May 16	17:05	41.7	0.00	49.2	21.3	15.6	1065
May 16	17:05	42.3	0.02	49.2	21.3	15.6	1046
May 16	17:05	42.3	0.00	49.4	21.3	15.6	1049
May 16	17:05	42.3	0.00	49.0	21.3	15.6	1036

AIR INFILTRATION TESTS - RESULTS

BLDG. 'C' - 6TH FLR.  
UPPER FAN OFF.

LEGEND:

DPB denotes pres. dif (Pa) between test & lower floors  
 DPU denotes pres. dif (Pa) between test & upper floors  
 DPO denotes pres. dif (Pa) between test floor & outdoors  
 Ti denotes test floor temperature (deg.C)  
 To denotes outdoor temperature  
 BM Vel denotes bell mouth velocity (fpm)

	DPB	DPU	DPO	Ti	To	BM Vel
May 16 17:12	0.00	39.0	50.0	21.3	15.6	1323
May 16 17:12	0.9	39.4	49.4	21.3	15.6	1325
May 16 17:12	1.2	39.5	50.1	21.3	15.6	1365
May 16 17:12	1.1	39.8	50.4	21.3	15.6	1346
May 16 17:12	1.4	40.0	50.0	21.3	15.6	1348
May 16 17:12	1.6	39.7	49.6	21.3	15.6	1354
May 16 17:13	2.3	39.8	49.7	21.3	15.6	1387
May 16 17:13	1.2	38.9	50.3	21.3	15.6	1373

AIR INFILTRATION TESTS - RESULTS

BLDG 'C' - 6TH FLR.  
ELEV. (1) UNSEALED.

LEGEND:

DPB denotes pres. dif (Pa) between test & lower floors  
 DPU denotes pres. dif (Pa) between test & upper floors  
 DPO denotes pres. dif (Pa) between test floor & outdoors  
 Ti denotes test floor temperature (deg.C)  
 To denotes outdoor temperature  
 BM Vel denotes bell mouth velocity (fpm)

	DPB	DPU	DPO	Ti	To	BM Vel
May 16 17:18	0.6	0.5	49.9	21.2	15.7	1407
May 16 17:18	0.00	0.3	50.0	21.2	15.7	1414
May 16 17:18	0.00	0.6	50.1	21.2	15.7	1407
May 16 17:18	1.4	1.1	50.4	21.2	15.7	1395
May 16 17:19	0.7	0.3	49.8	21.2	15.7	1404
May 16 17:19	0.00	0.2	50.1	21.2	15.7	1418
May 16 17:19	0.00	0.2	50.2	21.2	15.7	1401

AIR INFILTRATION TESTS - RESULTS

BLDG. 'C' - 6TH FLR.  
ELEV. & STAIR UNSEALED

LEGEND:

DPB denotes pres. dif (Pa) between test & lower floors  
 DPU denotes pres. dif (Pa) between test & upper floors  
 DPO denotes pres. dif (Pa) between test floor & outdoors  
 Ti denotes test floor temperature (deg.C)  
 To denotes outdoor temperature  
 BM Vel denotes bell mouth velocity (fpm)

	DPB	DPU	DPO	Ti	To	BM Vel
M y 16 17:21	3.0	1.7	50.2	21.1	15.8	1806
M y 16 17:21	1.5	1.4	50.2	21.0	15.8	1785
May 16 17:21	2.1	1.6	50.2	21.0	15.8	1764
May 16 17:21	2.2	1.0	49.5	21.0	15.8	1739
M y 16 17:22	2.0	1.1	49.8	21.0	15.8	1771
May 16 17:22	2.7	1.5	49.8	21.0	15.8	1770
May 16 17:22	2.2	1.9	50.4	21.0	15.8	1786
M y 16 17:22	2.3	0.7	50.1	21.0	15.8	1774

**AIR INFILTRATION TESTS - RESULTS**

BLDG. 'C' - 7TH FLR.

**LEGEND:**

DPB denotes pres. dif (Pa) between test & lower floors  
 DPU denotes pres. dif (Pa) between test & upper floors  
 DPO denotes pres. dif (Pa) between test floor & outdoors  
 Ti denotes test floor temperature (deg.C)  
 To denotes outdoor temperature  
 BM Vel denotes bell mouth velocity (fpm)

		DPB	DPU	DPO	Ti	To	BM Vel
		Pa	Pa	Pa	deg.C	deg.C	
May 16	14:38	0.7	0.3	19.8	21.5	15.9	238.1
May 16	14:39	1.0	0.6	20.2	21.5	15.9	238.9
May 16	14:39	0.9	0.5	20.1	21.5	15.9	236.6
May 16	14:39	0.6	0.1	20.0	21.5	15.9	222.0
May 16	14:39	0.5	0.00	19.7	21.5	15.9	229.1
May 16	14:39	0.9	0.3	20.4	21.5	15.9	241.8
May 16	14:39	0.7	0.4	20.0	21.5	15.9	226.3
May 16	14:39	0.5	0.1	19.8	21.5	15.9	227.8
May 16	14:39	0.1	0.00	19.8	21.5	15.9	216.3

AIR INFILTRATION TESTS - RESULTS

BLDG. 'C' - 7<sup>TH</sup> FLR.

LEGEND:

DPB denotes pres. dif (Pa) between test & lower floors  
 DPU denotes pres. dif (Pa) between test & upper floors  
 DPO denotes pres. dif (Pa) between test floor & outdoors  
 Ti denotes test floor temperature (deg.C)  
 To denotes outdoor temperature  
 BM Vel denotes bell mouth velocity (fpm)

	DPB	DPU	DPO	Ti	To	BM Vel
	Pa	Pa	Pa	deg.C	deg.C	
May 16 14:45	0.00	0.4	30.0	21.5	16.0	264.8
May 16 14:45	0.4	0.7	30.6	21.5	16.0	262.0
May 16 14:45	0.00	0.2	29.9	21.5	15.9	246.9
May 16 14:45	0.00	0.3	29.7	21.5	15.9	255.0
May 16 14:45	0.00	0.3	30.1	21.5	15.9	259.0
May 16 14:45	0.00	0.2	30.5	21.5	15.9	251.0
May 16 14:45	0.00	0.05	30.3	21.5	15.9	257.8
May 16 14:45	0.00	0.00	29.4	21.5	15.9	250.1
May 16 14:45	0.00	0.00	29.3	21.5	15.9	252.4



AIR INFILTRATION TESTS - RESULTS

BLDG. 'C' - 7<sup>TH</sup> FLR.

LEGEND:

DPB denotes pres. dif (Pa) between test & lower floors  
 DPU denotes pres. dif (Pa) between test & upper floors  
 DPO denotes pres. dif (Pa) between test floor & outdoors  
 Ti denotes test floor temperature (deg.C)  
 To denotes outdoor temperature  
 BM Vel denotes bell mouth velocity (fpm)

	DPB Pa	DPU Pa	DPO Pa	Ti deg.C	To deg.C	BM Vel
May 16 14:51	0.9	0.9	39.4	21.5	16.0	333.5
May 16 14:51	1.4	1.2	39.8	21.5	16.0	331.5
May 16 14:51	1.1	1.1	39.6	21.5	16.0	313.3
May 16 14:51	0.3	0.00	39.1	21.5	16.0	306.0
May 16 14:51	0.1	0.00	39.3	21.5	16.0	317.0
May 16 14:51	0.2	0.07	39.8	21.5	16.0	312.8
May 16 14:51	0.4	0.00	40.2	21.5	16.0	317.0
May 16 14:51	0.6	0.3	40.7	21.5	16.0	340.5

AIR INFILTRATION TESTS - RESULTS

BLDG. 'C' - 7TH FLR

LEGEND:

DPB denotes pres. dif (Pa) between test & lower floors  
 DPU denotes pres. dif (Pa) between test & upper floors  
 DPO denotes pres. dif (Pa) between test floor & outdoors  
 Ti denotes test floor temperature (deg.C)  
 To denotes outdoor temperature  
 BM Vel denotes bell mouth velocity (fpm)

	DPB Pa	DPU Pa	DPO Pa	Ti deg.C	To deg.C	BM Vel
May 16 14:57	2.3	0.00	50.2	21.5	15.9	336.0
May 16 14:57	2.4	0.00	49.4	21.5	15.9	325.0
May 16 14:57	2.6	0.00	49.2	21.5	15.9	354.0
May 16 14:57	2.4	0.00	49.4	21.5	15.8	370.5
May 16 14:57	2.9	0.00	49.7	21.5	15.8	373.5
May 16 14:57	3.4	0.00	50.2	21.5	15.8	374.0
May 16 14:57	3.3	0.4	50.4	21.5	15.8	375.0
May 16 14:57	3.6	0.7	50.8	21.5	15.8	379.0
May 16 14:58	3.7	0.00	50.5	21.5	15.8	369.6
May 16 14:58	3.3	0.00	50.0	21.5	15.7	370.5
May 16 14:58	3.6	0.00	49.8	21.5	15.7	382.5

AIR INFILTRATION TESTS - RESULTS

BLDG. 'C' - 7TH FLR  
ELEV. (1) UNSEALED

LEGEND:

DPB denotes pres. dif (Pa) between test & lower floors  
 DPU denotes pres. dif (Pa) between test & upper floors  
 DPO denotes pres. dif (Pa) between test floor & outdoors  
 Ti denotes test floor temperature (deg.C)  
 To denotes outdoor temperature  
 BM Vel denotes bell mouth velocity (fpm)

		DPB	DPU	DPO	Ti	To	BM Vel
		Pa	Pa	Pa	deg.C	deg.C	
May 16	15:03	1.4	0.3	50.3	21.4	16.0	1489
May 16	15:04	1.5	0.00	49.9	21.4	16.0	1466
May 16	15:04	0.5	0.00	49.8	21.4	16.0	1478
May 16	15:04	0.6	0.00	49.9	21.4	16.0	1475
May 16	15:04	2.1	0.2	50.2	21.4	16.0	1511
May 16	15:04	1.9	0.2	49.8	21.4	16.0	1501
May 16	15:04	2.6	0.9	50.0	21.4	16.0	1541
May 16	15:04	1.5	0.9	49.8	21.4	16.0	1537
May 16	15:04	2.2	0.6	50.0	21.4	16.0	1549
May 16	15:04	2.0	0.7	50.2	21.4	16.0	1540
May 16	15:04	2.9	0.9	50.4	21.4	16.0	1595
May 16	15:04	2.4	0.2	49.8	21.3	16.0	1536
May 16	15:04	3.1	0.1	50.1	21.3	16.0	1555

AIR INFILTRATION TESTS - RESULTS

BLDG. 'C' - 7TH FLR.  
ELEV. & STR. UNSEALED.

LEGEND:

DPB denotes pres. dif (Pa) between test & lower floors  
 DPU denotes pres. dif (Pa) between test & upper floors  
 DPO denotes pres. dif (Pa) between test floor & outdoors  
 Ti denotes test floor temperature (deg.C)  
 To denotes outdoor temperature  
 BM Vel denotes bell mouth velocity (fpm)

	DPB Pa	DPU Pa	DPO Pa	Ti deg.C	To deg.C	BM Vel
1 : 09	1.7	0.9	50.0	21.1	15.5	1767
15:10	0.8	0.5	49.7	21.1	15.5	1771
15:10	0.8	0.8	49.4	21.1	15.5	1761
1 : 10	1.2	1.6	50.3	21.1	15.5	1799
15:10	1.1	1.2	50.3	21.0	15.5	1815
15:10	1.1	0.8	50.0	21.0	15.5	1767
1 : 10	2.1	1.5	50.0	21.0	15.5	1797

**APPENDIX "F"**

**IAQ MONITORING RESULTS**



**AIR QUALITY MONITORING RESULTS**

**Building "D"**

Mar. 20, '91

Note: The hall pressurization and garage exhaust fans were found off.

Carbon Monoxide	<u>Time</u>	<u>Floor</u>	<u>Concentration</u>
	9:00	Lobby	6 ppm
after car idling	9:15	Lobby	11 ppm
	9:30	1st	4 ppm
	9:35	2nd	4 ppm
	9:40	3rd	3 ppm
	9:45	4th	5 ppm
	9:50	5th	5 ppm
	9:55	6th	6 ppm

Carbon dioxide was 480 ppm in lobby at 9:00 and over 700 ppm in the 4th floor hallway at 9:45.

**Building "E"**

Mar. 21, '91

Note: All common area fans in operation.

Carbon Monoxide	<u>Time</u>	<u>Floor</u>	<u>Concentration</u>
	9:15	Lobby	3 ppm
	10:00	5th	2 ppm

Carbon dioxide was 490 ppm in the lobby at 9:15.

**APPENDIX "G"**

**CLIMATE & METEOROLOGICAL DATA**



Victoria, B. C. enjoys a mild, maritime climate. Situated as it is on the southeastern tip of Vancouver Island, it is bounded by water on the south and east. Juan de Fuca Strait, some 18 miles wide, to the south of Victoria, lies between southern Vancouver Island and Washington State, U. S. A. Haro Strait, the Gulf Islands and the Strait of Georgia lie to the northeast between eastern Vancouver Island and the mainland.

The Olympic Mountain Range in Washington, some 25 to 30 miles to the south, rises sharply to 4000 to 5000 feet with Mount Angeles at a height of 6500 feet and Mount Olympus at 7913 feet. This range of mountains tends to shelter us from the major precipitation effects of many Pacific storms, since moisture laden air, from a southerly direction, may be dried considerably in passing northward across the mountain barrier, to produce a rain shadow across this region. Some increasing in shower activity results over the area when cool moist air from the northwest is forced to rise on the northern slopes of this mountain range.

A lower range of hills or mountains on southern Vancouver Island ranging from 1000 to 3000 feet give protection from moist westerly winds from the Pacific Ocean with the air being dried considerably as it drops much of its moisture on the windward or western slopes.

Normally this area is under the influence of a mild westerly circulation of air from the Pacific Ocean which in summer gives rise to pleasantly warm weather with abundant sunshine and some showery periods, while in the winter provides generally mild weather with considerable cloudiness and periods of rain. However periods of northerly winds in summer gives rise to clear hot weather, while these winds in winter keep the weather cool and mostly cloudy. Masses of very cold continental Arctic air, which from time to time pour southward into the interior of British Columbia and the Prairie Provinces, very infrequently reach Victoria, during the winter season. These outbreaks of cold, dry air are accompanied by a period of snow and strong northeasterly winds and followed by clearing and much colder weather. This is normally followed within a few days by a trend to milder weather with snow changing rapidly to rain as the temperatures rise with the arrival of the milder air from the Pacific Ocean. The highest temperature recorded during the summer has been 95.2 degrees on July 17, 1941 while the lowest winter temperature has been 3.8 degrees on December 29, 1968.

Extremely low humidities are not common but do occur with the warm dry northerly winds for short periods in the summer and the cool dry Arctic air which infrequently invades this area in the winter. Average relative humidity for Victoria in the summer months is 79 percent and in winter 86 percent.

The prevailing wind direction, as determined by the number of hours the wind blows from each direction, is from the North, during the months of October through to February, and from the Southwest during the period May to September, and from the West during March and April. Winds of gale force from the Southeast and Southwest, preceding and following Pacific storms onto the coast, are quite common in the winter months while a sea breeze from the Southwest is common during the summer afternoons.

ANNUAL METEOROLOGICAL SUMMARY FOR - VICTORIA, B. C.

Page 4

C L I M A T E (continued)

The cooling effect of this sea breeze is felt at Gonzales Observatory and along the southern shoreline of Victoria, and to a lesser degree northward away from the shoreline. Therefore temperatures experienced here with the afternoon sea breeze will be lower than those further inland from the water and the extent will depend upon the strength of the resultant penetration of the cooler air over the land areas.

With northerly winds, air reaches this observing point after passing over the land area to our north. Therefore temperatures as recorded here with northerly winds are representative of the Greater Victoria area. With clear skies and light winds at night, the cooling air collects in low lying more sheltered areas and temperatures are normally much lower in these areas than they are at the Observatory. The mixing and stirring of the air produced by the wind tends to minimize the temperature difference under stronger wind conditions. Therefore temperature observations taken in more sheltered areas of Victoria tend to be higher on the average during the summer months and lower during the winter months, than those recorded here. However over the year, the average temperature for all stations is near 50 degrees.

Victoria has the highest average number of hours of bright sunshine in British Columbia and one of the highest in Canada. Its average of just over 2200 hours of sunshine is exceeded by less than 100 hours by several stations on the southern prairies.

Patches of fog form from time to time, in low lying areas, during the Fall and Winter seasons but widespread heavy fog occurs very infrequently. During the Summer months banks of fog form in a northwesterly circulation of air along the West Coast of Vancouver Island, drift eastward through Juan de Fuca Strait and may invade the Victoria shoreline in the morning hours and retreat from the shoreline during the day.