

#4543

NO.27  
(1990)

BUILDING RESEARCH ASSOCIATION OF NEW ZEALAND

# BRANZ STUDY REPORT

CI/SIB

(Xt4) (H6)

UDC

692.843

## *DRAUGHT CONTROL SYSTEMS FOR NEW ZEALAND HOUSES*

**M. R. Bassett and  
H. M. Beckert**

**BRANZ**

BUILDING RESEARCH ASSOCIATION OF NEW ZEALAND

## PREFACE

This report on a project carried out at the Building Research Association of New Zealand describes an investigation on the role of draught sealing measures in houses and is part of a wider programme concerned with overcoming heat and moisture problems in buildings.

## AUDIENCE

This report is intended primarily for manufacturers of draught control materials and research workers concerned with energy and ventilation in houses.

## CONTENTS

	Page
INTRODUCTION	1
DISCUSSION OF THE LITERATURE	2
DRAUGHT AND WEATHER SEALS - GENERIC TYPES	3
Draught Seal types for Opening Joinery	3
Drained Joint Weather Seals	3
PERFORMANCE CRITERIA FOR DRAUGHT SEALS	4
Durability of Draught Seal Materials	4
Airtightness Targets	6
Acceptable Closing Forces	6
METHODS OF TESTING DRAUGHT SEALS	7
Air Leakage Through Draught Seals	7
Resistance to Compression	8
RESULTS	8
Air Leakage	8
Compression	8
Air Leakage and Compressibility	9
CONCLUSIONS	9
RECOMMENDATIONS	10
Draught Strips	10
Door Threshold Seals	10
REFERENCES	11
APPENDIX A: Air Infiltration In Houses	13
Airtightness of New Zealand Houses	13
Domestic Building Airtightness Standards	13
Winter Heat Loss and Condensation Control	14
The Airtightness of Opening Joints around Doors and Opening Windows	14
APPENDIX A REFERENCES	16
APPENDIX B: Infiltration Degree Days for Four New Zealand Locations	16
Heating Degree Days	17
Heating Infiltration Degree Days for New Zealand	18
Building Airtightness	18
APPENDIX B REFERENCES	20



## FIGURES

	Page
FIGURE 1: Generic types of retrofit draughtseals	21
FIGURE 2: Schematic of threshold seal incorporating separate rain screen, drained cavity and air seal	22
FIGURE 3: Experimental arrangement for measuring leakage characteristics of draught seals	22
FIGURE 4: Air leakage through a draught seal compressed and with an air gap	23
FIGURE 5: The dependence of compressibility of a foam strip on rate of compression	24
FIGURE 6: The airtightness of a wide range of draught seals as a function of compression	25
FIGURE 7: Airtightness and compliance of a V strip (sample 3)	26
FIGURE 8: Airtightness and compliance of a foam strip (sample 7)	27
FIGURE 9: Airtightness and compliance of a foam strip (sample 10)	28
FIGURE 10: Airtightness and compliance of a brush seal (sample 15)	29
FIGURE 11: Airtightness and compliance of a tubular strip (sample 19)	30
FIGURE 12: Summary of the working range of draught seals consistent with airtightness and closing force criteria	31
FIGURE 13: Histogram of airtightness values for New Zealand houses built between 1962 and 1982	32
FIGURE 14: Distribution of normalised leakage areas for NZ houses and leakage classifications	32



## TABLES

	Page
TABLE 1: Generic types of draught seals	3
TABLE 2: Generic types of door threshold seals	4
TABLE 3: Ageing characteristics of draught strip materials	5
TABLE 4: Window air leakage rates from NZS 4211:1985	6
TABLE 5: Airtightness of threshold seals	8
TABLE 6: Air leakage through components at 50 Pa	15
TABLE 7: Heating and infiltration degree days in New Zealand	18
TABLE 8: Leakage classes and acceptable infiltration degree day totals from proposed ANSI/ASHRAE standard (1987)	19





## DRAUGHT CONTROL SYSTEMS FOR NEW ZEALAND HOUSES

BRANZ Study Report SR27

M.R. Bassett and H.M. Beckert

### REFERENCE

Bassett M.R. and Beckert H.M. 1989. Draught Control Systems for New Zealand Houses. Building Research Association of New Zealand Study Report SR27, Judgeford.

### KEYWORDS

From Construction Industry Thesaurus - BRANZ edition: Air; Draughts; Houses; Leakage; Sealing; Ventilation; Weather resistance; New Zealand.

### ABSTRACT

Draught-sealing materials are intended for eliminating nuisance draughts and saving space heat, and are widely available in the marketplace for these purposes. Improvements in house airtightness have generally been found unnecessary in New Zealand to prevent unacceptable heat losses, or to meet standards for residential airtightness established in similar overseas climates. Energy and ventilation aside, however, there will be occasions where draughts cause some physical discomfort and this problem can be effectively dealt with by a variety of draught sealing systems. This paper examines the role that draught seals can play in the opening joints of doors and opening windows and suggests levels of performance which should be achieved. Draught seals need to be extremely easily compressible to avoid excessive closing forces. Many of the systems available were found to be too stiff to cope with varying sized gap widths around a warped door. Of the seals available for retrofit application only one generic type was sufficiently tolerant of varying gap width. Most of the materials were found to be adequately airtight.

Threshold seals on external doors have to resist rain and air penetration as well as being mechanically robust and resistant to sunlight. In consequence they tend to be more complicated and bulky than perimeter strips. Most threshold seals were found to achieve adequate airtightness but few were found to separate the air sealing and rain screen functions necessary for optimum protection against rain.



## INTRODUCTION

Air leaks around doors and windows can cause unacceptable draughts in some parts of a house, but can also usefully contribute to ventilation. Draught stopping is often seen as a way of saving energy, but if carried to extremes, there could be too little ventilation to provide satisfactory air quality and to cope with indoor moisture. In adequately airtight houses, the role for draught stripping would be limited to improving the standard of thermal comfort in some rooms by eliminating draughts.

This report examines the airtightness of New Zealand (NZ) houses to see if improvements can be made that are consistent with moisture control and energy efficiency. It also examines airtightness standards in countries with similar climates to NZ to help show whether changes in building airtightness would be of value.

The main role of draught seals around doors or opening windows is to act as an airtight plug, at the same time not imposing unacceptable closing forces. Adequate airtightness and compressibility were therefore seen as essential characteristics that could be specified and measured. There are other desirable qualities in retrofit draught sealing materials. They must be practical to apply and resistant to moisture and sunlight, and should retain their properties with use. The two main objectives of this study were as follows:

- . To clarify levels of performance required of draught seals in joints between opening building components.
- . To test samples of generic types of draught seals against these requirements.

Weather-seals were also investigated; in particular, external door threshold seals which have a dual role of excluding air and rain. Here the air seal and rain screen functions should ideally be located at different places to achieve a drained joint, thus requiring two pieces of hardware. The drained joint formed will be both weathertight and tolerant of inaccurate fit. This study deals experimentally with the air sealing function and discusses the design objectives of the rain screen.

## DISCUSSION OF THE LITERATURE

Höglund and Wångren (1980) measured the airtightness and compressibility of a large range of draught strips and evaluated the data in the light of airtightness standards for Swedish buildings and the need for doors and windows to be easily closed by handicapped people. The range of draught strips they tested was extensive and generally unavailable in NZ. They had to be more airtight than is considered necessary in NZ, because of the extreme winter climate in Sweden.

There are a number of guides that discuss the range of draught seals and their influence on air infiltration, heat losses and ventilation needs. Building Research Establishment Digest 306 (1986) gives ventilation rates necessary to remove moisture and supply combustion appliances and warns against draught-proofing houses to the point where ventilation is likely to be reduced below these essential levels. Potter (1982) raised the same issues and ranked draught seals of a range of profiles and materials according to application, durability, visibility after installation, cost and installation difficulty. Building Research Establishment Digest 319 (1987) surveyed the size of gaps around doors and windows and discussed costs and benefits to be expected from draught sealing.

Draught seals have received attention in a number of NZ publications concerned with energy efficient housing. Warren, Kember and Hass (1983) in "How to Heat Your Home" described a wide range of draught excluders and airtightening procedures. They also warn that ventilation to control moisture and remove combustion gases from portable gas heaters must be maintained. The skill required to apply draught seals and their overall appearance has been discussed in the popular literature e.g. Consumers' Institute (1986)





Air infiltration in New Zealand houses has been investigated by Bassett (1983, 1984, and 1984a) and a summary of results leading to the conclusion that most new houses were adequately airtight is given in Appendix A. The implication is that air infiltration does not generally over-ventilate houses, therefore draught sealing to save energy can rarely be justified. Indeed it can be argued that enhanced ventilation using active or passive ventilators may be a more important addition to houses to help control moisture when living styles work against open windows.

## DRAUGHT AND WEATHER SEALS - GENERIC TYPES

## Draught Seal Types for Opening Joinery

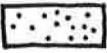
There are a number of generic types of draught seal which can be distinguished by their shape or, more particularly, by the way the material is shaped to achieve an easily compressible strip. The most common generic type is a foamed strip but there are other ways of making a compressible seal; for example, by forming a hollow tube or by folding a narrow strip of material. Diagrams of the main generic types are given in Figure 1. A list of the generic types of perimeter strips available for retrofit application is given below in Table 1 together with a symbol for convenient identification in this report.

Table 1 Generic types of draught seals

Name	Symbol	Description
Foam strips		Foamed plastic or rubber strip adhesive backed.
Tubular 'O' strips		Extruded hollow plastic strip fitted to holder.
Folded 'V' strips		Folded strip of solid or foamed plastic, adhesive backed.
Brush seals		Fibre brush, adhesive backed with or without a draught control fin.

## Drained Joint Weather Seals

Keeping the rain from penetrating under a door can involve quite different techniques to draught sealing. Successful weather seals tend also to be good draught seals but they separate the water shedding part of the joint from that which makes the air seal. Figure 2 shows one way of arranging a rain screen, an air seal and a gravity drained cavity separating the two, to achieve a drained joint. The external rain screen shields the joint from direct rain entry, sheds runoff from above and acts as a drip nose to prevent water travelling into the joint by surface tension. The cavity is sloped to outside and is wide enough (in excess of 6 mm) to avoid being bridged by surface tension. This means that any water that is blown past the rain screen will drain freely to outside and not wet the air seal. Once the air seal has been wet, wind pressures will blow water inside.

Table 2 lists the main generic types of threshold seal available locally for retrofit application, together with the role for which the component was considered most effective, viz: rain screen and drip nose, and air seal. There are several threshold seals intended for interior doors that require an air seal which can move easily over carpet.

Table 2 Generic Types of Door Threshold Seal

Sample	Function		Description
	Air seal wet	Rain screen dry	
1		X	Flexible air seal attached to door tread
2		X	Flexible air seal on underside of door makes contact with extruded aluminium door tread
3	X	X	PVC Wiper seal attached to outside lower edge of door.
4	X	X	Retracting rain screen and air seal attached to outside lower door edge.

There are many threshold seals for doors but most perform only one function, i.e, rain screen or dry air seal. Achieving a drained joint will require a product of each type or a single product performing both functions. The air seal will also have to be situated where it remains dry.

#### PERFORMANCE CRITERIA FOR DRAUGHT SEALS

##### Durability of Draught Seal Materials

The lifetime of a draught seal will depend on the composition of the rubber or plastic components and exposure to sun and moisture. There are differences in durability, with materials such as EPDM (ethylene propylene diene monomer) lasting several times as long as polyurethane foam in the presence of light and moisture, (Sharman and van Gosliga (1989)). For this reason, durability will be an important part of the cost effectiveness of draught sealing systems. A list of the materials found in draught seals available for retrofit use is given in Table 3 along with the likely mode of failure and probable lifetime in a joint around an exterior door or window.

Table 3 Aging characteristics of draught strip materials

Application	Material	Ageing characteristics
Foam strip	polyurethane open cell foam	Sensitive to sunlight and moisture. Short life expectancy *.
Foam rubber	natural	Degraded by ozone and sunlight and more durable if black. Short life expectancy.
	PVC foam	Plasticiser migration (hardens, and shrinks), embrittlement. Medium life expectancy.
	EPDM foam	High life expectancy.
Brush seal	nylon	Degraded by sunlight. Low life expectancy.
Tubular strip	solid EPDM	High life expectancy.
	solid neoprene	Hardens with age. High life expectancy.
	plasticised PVC	Hardens with age. Medium life expectancy.
Folded strip	polypropylene	Degraded by sunlight. Medium life expectancy if dark colour. High if black.

\* Life expectancy less than 2 y = short, 2-7 y = medium, above 7 y = high

## Airtightness Targets

Airtightness levels are given for three categories of window in NZS 4211 : 1985 Specification for Performance of Windows, labelled 2, 8 and 17. They are reproduced below in Table 4 together with calculated leakage rates at 50 Pa.

Table 4 Window air leakage rates from NZS 4211:1985

Rate of air leakage litres/second	l/s		
	LEVEL 2	LEVEL 8	LEVEL 17
Per m <sup>2</sup> of total window area at 150 Pa	2	8	17
Per m of opening joint length at 150 Pa	0.6	2	4
Per m of opening joint length at 50 Pa	0.3	1	2

Level 2 is recommended for air-conditioned buildings and in other demanding situations. Level 8 is for general use and level 17 for undemanding situations. Level 8 is typical of the leakage rates allowed in countries with similar climates to NZ as summarised by Jackman and Liddament (1985) and is suggested here as the level to be achieved by draught-stripped domestic windows.

There are no recommendations for minimum leakage rates around doors in New Zealand. The Revised Norwegian Thermal Insulation and Airtightness Regulations (1980) and the Swedish Building Code with Comments SBN (1980) require external doors to meet the same airtightness standards as windows. The Canadian Measures for Energy Conservation in New Buildings No 16574 (1978) and ASHRAE Standard 90-80 Energy Conservation in New Building Design (1980), take separate account of doors, allowing a leakage rate equivalent of 1.5 l/s.m (litres/second meter) at 50 Pa. This level of airtightness could be achieved with 1 l/s.m around the jamb and a more relaxed 2 l/s.m for the more difficult to seal threshold joint. In the absence of any current recommendation for the airtightness of doors in New Zealand, an overall level of 1.5 l/s.m (threshold included) at 50 Pa is suggested. This can be best achieved by asking for level 8 around the jamb and level 17 along the threshold joint.

## Acceptable Closing Forces

A draught strip must not require excessive force to make a satisfactory seal and it should be able to accommodate variations in gap width typical of a slightly warped wooden door. Closing forces for windows are well defined in NZS 4211:1985. Maximum closing forces are given as 120 N for sliding sashes and 160 N for all other types. Where the window area exceeds 1 m<sup>2</sup> the force can be increased in proportion to area. In translating these figures into a force per metre of joint length, consideration must be given to the likely range of window sizes as well as



leverage effects at the hinge end of swung windows. For common window sizes and shapes, a compression force of 50 N per metre of joint should allow closing with less than the NZS 4211 force.

Door-closing forces are less well specified. There are few international building standards recommending closing forces, for example, NZS 4121:1985 Code of Practice for Design for Access and use of Buildings and Facilities by Disabled Persons, is no more specific than requiring doors to be openable with one hand. Design guides on building design for disabled people are more specific but give a variety of closing forces. Harkness and Groom (1976) recommend a force of 36 N and Höglund and Wångren (1980) prefer 25 N. The issue is further complicated by the appreciable momentum of a swinging door and the high static closing forces this can overcome. Two methods of determining closing forces are described by Höglund and Wångren (1980), one applies a steady force to the door handle over the last 200 mm of closing and the other measures the static force required to engage the lock. Typically the force required using the slamming action (dynamically) was 0.1 times that required statically. The 25 N slamming action they recommend translates to a 230 N static closing force. The authors of this report consider that people do not like having to slam doors this hard and recommend the closing forces for windows be applied to doors. This is 50 N/m which corresponds to a static door closing force of about 150 N. This makes doors easy to close with some assistance from momentum.

## METHODS FOR TESTING DRAUGHT SEALS

### Air Leakage through Draught Seals

An unguarded pressure box method shown in Figure 3 was used to apply an air pressure difference across a sample mounted in a crack of known width. Air flow rates were measured with a rotameter of appropriate size both with the seal in place and with the seal masked to give the background leakage. Pressures were induced with a fan upstream of the rotameter and were measured with a 0-1000 Pa micromanometer.

The difference between total and background leakage was determined at a range of pressures between 10-200 Pa and a leakage versus pressure function of the following type fitted to the data.

$$L = K \Delta P^n$$

where

- L = leakage rate l/s.m
- K = leakage constant
- $\Delta P$  = applied pressure difference Pa
- n = exponent

For physical reasons, the exponent must lie in the range  $0.5 < n < 1$ . The higher limit of  $n = 1$  characterises flow through porous materials but for air leakage through cracks between building materials, the flow is generally turbulent and the exponent approaches the lower limit of  $n = 0.5$ . Figure 4 shows how the exponent in the leakage function changes as a typical draught seal is compressed. For this particular foam strip sample the  $n = 1$  limit was approached when the strip was compressed.

The leakage function was used to calculate the leakage at 50 Pa which was recorded for a range of crack widths between a tightly compressed seal at one extreme to a gap wider than the seal at the other.

## Resistance to Compression

Compression forces were applied continuously over a range of crack widths using an Instron universal testing machine. A jig was made to ensure that lateral forces were resisted as they are by a door or window constrained by hinges. Forces between 0-200 N/m were applied with an accuracy of 5 N/m and the gap width was determined to within 0.1 mm.

The compression characteristics of draught seals were expected to be independent of the rate of compression but this was checked experimentally for a selection of materials. Rate dependent compression characteristics would have implications for practical closing forces. Figure 5 shows compression forces plotted against displacement for a range of speeds. No significant speed-dependent effects were observed.

## RESULTS

### Air Leakage

Most of the draught strips and threshold air seals met the target leakage rate with 1 mm or more compression. The only exceptions were brush seals which required several mm of compression to be adequately airtight. These seals are normally used between sliding door components and improved airtightness is sometimes achieved with a plastic strip or fin midway through the brush. This was absent in both tested examples of brush seal. The variation in leakage with gap width is illustrated in Figure 6. Here it is shown that most compression seals (indicated by the shaded area) leaked less than 1 l/s.m at 50 Pa with 1mm or greater compression and that the leakage rate increased sharply when the seal broke contact. Draught seals clearly have to make contact at all points around the perimeter of a window or door to meet the suggested air leakage criteria.

Threshold airseals were found to be more difficult to make airtight. Table 5 lists the leakage rates measured for the four systems, all of which were designed to achieve either a wet or dry airseal. Samples 3 and 4 fell short of the suggested airtightness target of 2 l/s.m. Descriptions of these threshold seals are given in Table 2.

Table 5 Airtightness of threshold seals

Sample	air leakage rate at 50Pa l/s.m
1	1.6
2	1.6
3	7.1
4	4.1

### Compression

85 per cent of draught strips tested could not be compressed more than 2 mm before the force needed for further compression exceeded 50 N/m. 65 per cent could only be compressed up to 1 mm before the 50 N/m mark was passed. The V strips were a notable exception and could be compressed up to 8 mm before 50 N/m force was reached. Actual gaps between door and jamb

often vary by 5mm or more, suggesting it will be important to select the correct draught seal.

### Air Leakage and Compressibility

Figures 7-11 display the airtightness and closing force characteristics of a range of draught strips. Both the air leakage rate and the closing force are drawn on the same graph as a function of crack width. The solid line is the air leakage rate and the dashed curve the closing force. Both assume a 1 m length of crack and have to be multiplied by the joint length to yield total air leakage rates and closing force. The range of compression between achieving adequate airtightness of 1 l/s.m, and reaching a compression force of 50 N/m determines the tolerance of a draught seal to warp or variation in the gap to be filled. Figure 12 summarises the working range for each draught seal (dense shading) and the uncompressed thickness (light shading). The 'V strip' generic type was found to have the largest effective working range, which exceeded 8mm. For many materials, the working range was less than 1 mm and it is questionable whether they are ever likely to achieve the suggested airtightness and closing force levels in practice.

### CONCLUSIONS

This study of air and weather-seal characteristics has shown there would be little potential benefit from increasing the airtightness of houses built in New Zealand. Then, having identified draught control as a thermal comfort issue, the study has recommended performance criteria and tested generic types of draught seal with the following conclusions:

- 1) Levels of air leakage resistance and compressibility that comply with current New Zealand standards and that are unlikely to make domestic windows too difficult to close by handicapped people are as follows:

Airtightness - 1 l/s per metre at 50 Pa pressure difference  
 Closing force - 50 N per metre of opening joint

For doors the same criteria are suggested, with an exception that the airtightness of the threshold joint be relaxed to 2 l/s per metre at 50 Pa.

- 2) Most draught seals were adequately airtight with minimal compression. Brush seals without a draught control fin were found to require some compression to be sufficiently airtight.
- 3) Some types of draught seal were found to be more easily compressible than others and hence more tolerant of varying gap widths around doors and windows. The most compressible were V strips, followed by tubular strips, soft foam and lastly hard foam strips. Some draught seals were intolerant of gap width and are unlikely to achieve the above airtightness and compressibility criteria in practice.
- 4) None of the threshold seals investigated separated the airseal and rainscreen functions which is desirable for optimum weathertightness.

- 5) Half of the threshold seals were found to be adequately airtight without imposing unacceptable closing forces.

## RECOMMENDATIONS

### Draught Strips

A number of factors need to be considered in selecting a draught strip. They include cost, durability, airtightness, effect on closing forces, appearance and how easy the system is to install. This report makes the following recommendations concerning airtightness, closing force and durability:

1. Variation in the gap width to be filled should be inspected first. Where this exceeds 2-3 mm, a folded V strip is recommended.
2. Where there is little variation in gap width, any of the generic types investigated would be suitable as long as they are sufficiently durable.

### Door Threshold Seals

To achieve a drained joint at an external door threshold, an effective rain screen, drained cavity and air seal combination is recommended. This will generally require separate rainscreen and air seal hardware.

## REFERENCES

- American Society of Heating, Refrigerating and Airconditioning Engineers Inc., 1980 Energy Conservation in New Building Design. ASHRAE Standard 90-80.
- Bassett, M. 1983. Air Infiltration in New Zealand Houses. Proceedings of 4th. Air Infiltration Centre Conference, Air Infiltration Reduction in Existing Buildings. Elm Switzerland. 26-28 September.
- Bassett, M. 1984. Preliminary Survey of Airtightness Levels in New Zealand houses. Institution of Professional Engineers New Zealand, Transactions p 53-61 Vol. 2.
- Bassett, M. 1984a. Building Site Measurements for Predicting Air Infiltration Rates. American Society for Testing and Materials (ASTM) Symposium on Measured Air Leakage Performance of Buildings, Philadelphia 2-3 April.
- Building Research Establishment. 1986. Domestic Draughtproofing: Ventilation Considerations. Digest 306. Garston, Watford.
- Building Research Establishment. 1987. Domestic Draughtproofing: Materials, Costs and Benefits. Digest 319. Garston, Watford.
- Consumers Institute, 1986. Consumer, No. 237, April pp. 78-81. Wellington.
- Harkness, S.P. and Groom, J.N. 1976. Building Without Barriers for the disabled. The Architects Collaborative Inc. Cambridge Massachusetts. Watson-Guption Publications: New York.
- Höglund, Ingemar and Wångren, Bengt. 1980. Studies of the Performance of Weather Strips for Windows and Doors. Swedish Council for Building Research, Publication D4 Stockholm.
- Jackman, P.J. and Liddament, M.W. 1985. Building Airtightness Standards. Air Infiltration Review, Vol.6, No.2, February. The Air Infiltration Centre. Bracknell.
- National Research Council of Canada. 1978. Measures for Energy Conservation in New Buildings. Associate Committee on the National Building Code. No. 16574, Ottawa.
- National Swedish Board of Physical Planning and Building. 1980. Swedish Building Code with Comments. SBN 1980. Chapter 33.
- Potter, Jim. 1982. Draughtproofing Theory and Application. Freeman Paper No.2. Freeman Insulation Ltd. Cambridge.
- Royal Ministry of Local Government and Labour, Norway. 1980. Thermal Insulation and Airtightness. Revision of Building Regulations of 1st August 1969. Chapter 54.
- Sharman, W.R. and van Gosliga, N.L. 1989. Estimates of the Durability of Building Plastics and Rubbers in Exterior Applications. Building Research Association of New Zealand Study Report No. 19. Judgeford.

Standards Association of New Zealand. 1985. Code of Practice for Design for Access and Use of Buildings and Facilities by Disabled Persons. Wellington. NZS 4121:1985.

Standards Association of New Zealand. 1985. Specification for Performance of Windows. Wellington. NZS 4211:1985.

Warren, John H., Kember, Anthony and Haas, Anthony (Eds). 1983. How to Heat your Home : Lower your Costs, Increase your Comfort : a Consumer guide for New Zealand. Ministry of Energy and Asia Pacific Economic News. Wellington.

## Appendix A: Air Infiltration In Houses

### Airtightness of NZ houses

High grade airtight houses now successfully save space heat in countries with cold winters, notably Scandinavia and Canada. In NZ there has been little consideration given to airtight construction beyond requiring a reasonable standard of workmanship. There are no airtightness standards that have to be observed, although there are standards in place in a growing number of countries with climates similar to NZ.

House airtightness is normally reported as the number of house volume air changes (ac/h) that leak through the envelope when the whole house is subjected to an indoor/outdoor pressure difference of 50 Pa. While this result cannot easily be interpreted as an infiltration rate, it is useful for comparing the airtightness quality of houses because there is good comparative data available from other countries. Data from a survey of houses in Auckland, and Christchurch published by the New Zealand Energy Research and Development Committee (1986) and a survey of Wellington houses by Bassett (1985) have been combined to give the histogram of house airtightness in Figure 13.

A large group of houses (40%) fell within the 0-8 ac/h range occupied by pre-'airtightness standard' houses in very much colder climates such as those in Canada and Scandinavia. The median of 9.0 ac/h and the 10 and 90 percentile values of 5.2 ac/h and 23.7 ac/h respectively are comparable with houses of recent construction found in the UK and USA. New houses in NZ are not, as once thought, leaky by international standards.

### Domestic Building Airtightness Standards

Domestic airtightness standards were reviewed by Thompson (1984). In 1984 there were airtightness requirements for window and door components in many countries and minimum ventilation rates specified in some countries. There were only two complete house airtightness standards. These were the Swedish Building Code with Comments SBN 1980 which required single family detached buildings to achieve an air leakage rate of less than 3.0 ac/h at 50 Pa, and the Revised Norwegian Thermal Insulation and Airtightness Regulations (1980) which made similar airtightness recommendations. Since 1984 there have been more proposed new airtightness standards and one that is particularly relevant to NZ is the 119P standard published by the American Society of Heating, Refrigeration and Air Conditioning Engineers (ASHRAE), Air Leakage Performance for Detached Single-Family Residential Buildings (1987). Levels of airtightness are proposed for climatic regions defined by the total year infiltration degree days. Infiltration degree days are derived for selected NZ cities in Appendix B and on the basis of this data, houses in most climatic regions in the country would need to fall within leakage classes A to G to satisfy ASHRAE/ANSI 119P. Figure 14 is a histogram of measured normalised leakage areas for NZ houses which shows that most houses recently built in NZ are already sufficiently airtight to meet this standard. Houses in some exposed windy coastal areas might need to satisfy slightly tighter leakage classes A to F but most existing houses would still qualify. On this basis there is no reason for a call for generally higher standards of airtightness in NZ houses.

### Winter Heat Loss and Condensation Control

An analysis of infiltration heat losses and ventilation needs to control moisture has been completed by Bassett (1985), which drew the following conclusions:

1. Calculated winter infiltration rates generally fall in the range 0.2-1.0 ac/h. Unusual combinations of airtightness and wind exposure are required to give infiltration rates outside this range.
2. The infiltration load on space heating was calculated for an insulated house ranging between the 10 and 90 percentile levels of airtightness. It represented from 10 to 25% of the fabric heat loss.
3. There will be times in most houses when infiltration alone gives insufficient ventilation to control condensation. In general, the standard of heating and the opening of windows will have more control over condensation than will infiltration.

These conclusions argue against generalised improvements to the airtightness of NZ houses.

### The Airtightness of Opening Joints around Doors and Opening Windows

Homeowners are frequently exposed to advertising for draught-stopping materials. They may form the impression that most air leakage originates from these sources, but a survey of 20 houses by Bassett (1983) showed less than 25% of the total leakage occurs around doors and windows. This implies limited scope for improving the overall airtightness of houses by blocking leaks around openable joinery. In the survey there were no examples of retrofit draught seals and therefore no opportunity to measure the effectiveness of draught-sealing installations. A summary of building component leakage data is given in Table 6 together with the average house leakage rate at 50 Pa for comparison. More detailed leakage opening sizes in NZ houses can be found in Bassett (1984), and for houses in a range of countries, in Jackman and Liddament (1985).



Table 6 Air leakage through components at 50 Pa

Component	Max	Min	Mean	Units	
Average 100 m <sup>2</sup> house built 1978-1983			620	l/s	*
Wood frame external door	80	24	43	l/s	
" " /perimeter length	15	4.5	8	l/s.m	**
Aluminium ranchsliders			2.6	l/s.m	
Louvre windows			4.5	l/s.Louvre	
Domestic aluminium windows			0.5	l/s.m	
Domestic Wooden windows without gaskets			4	l/s.m	
Window architraves			0.7	l/s.m	
* l/s = litres/second					
** l/s.m = litres/second.metre					

## APPENDIX A REFERENCES

American Society of Heating, Refrigerating and Airconditioning Engineers Inc., (ASHRAE) 1987. Proposed American National Standard. Air leakage performance for detached single-family residential buildings. ANSI/ASHRAE 119P.

Bassett, M. 1983. Air Infiltration in New Zealand Houses. Proceedings of 4th. Air Infiltration Centre Conference, Air Infiltration Reduction in Existing Buildings. Elm Switzerland. 26-28 September.

Bassett, M. 1984. Preliminary Survey of Airtightness Levels in New Zealand houses. Institution of Professional Engineers New Zealand, Transactions p 53-61 Vol. 2.

Bassett, M. 1985. The Infiltration Component of Ventilation in New Zealand Houses. Air Infiltration and Ventilation Centre Proceedings of the 6th AIC Conference, Het Meerdal Park The Netherlands.

National Swedish Board of Physical Planning and Building. 1980. Swedish Building Code with Comments. SBN 1980. Chapter 33.

New Zealand Energy Research and Development Committee. 1986. Air Tightness Levels in Auckland and Christchurch Homes. Publication P87. Auckland.

Jackman, P.J. and Liddament, M.W. 1985. Building Airtightness Standards. Air Infiltration Review, Vol.6, No.2, February. The Air Infiltration Centre. Bracknell.

Royal Ministry of Local Government and Labour, Norway. 1980. Thermal Insulation and Airtightness. Revision of Building Regulations of 1st August 1969. Chapter 54.

Thompson, Catriona. 1984. A Review of Building Airtightness Standards. Air Infiltration and Ventilation Centre Technical Note AIC 14. Berkshire.

## Appendix B: Infiltration degree days for four New Zealand locations

## Nomenclature

$C_p$	Heat capacity of air (0.284 Wh/kg.K)
$E$	Heating loss (W.hr)
$F$	Free heat generated inside building (W)
$f_s$	Stack driven infiltration parameter ( $m^3/hr.cm^2.K$ )
$f_w$	Wind driven infiltration parameter ( $m^3.s/cm^2.hr$ )
HIDD	Heating infiltration degree days (C.day)
$L$	Normalised leakage
$s$	Specific infiltration ( $m^3/hr.cm^2$ )
$s_0$	Average specific infiltration ( $0.27 m^3/hr.cm^2$ )
$T_{in}$	Temperature inside building (C)
$T_{out}$	Temperature outside (C)
$T_b$	Base temperature for defining degree days (C)
$Q$	Total infiltration ( $m^3/hr$ )
$v$	Wind speed (m/s)
UA	Building envelope thermal conductivity (W/K)
$\rho$	Density of air (kg/m <sup>3</sup> )

### Heating degree days

The net conduction heat losses from a building can be summed over a year and expressed in terms of the thermal quality of the envelope, indoor-outdoor temperature difference and internally generated free heat as follows:

$$E = UA \sum_{\text{hours}} (T_{\text{in}} - T_{\text{out}}) - \sum_{\text{hours}} F \quad \text{for } T_{\text{in}} > T_{\text{out}}$$

Conventionally,  $T_{\text{in}}$  has been replaced with  $T_{\text{b}}$ , defined as follows to allow for typical free heat gains:

$$T_{\text{b}} = T_{\text{in}} - 1/UA \sum_{\text{hours}} F$$

so that

$$E = UA \sum_{\text{hours}} (T_{\text{b}} - T_{\text{out}}) \quad \text{for } T_{\text{b}} > T_{\text{out}}$$

Degree day data for a range of New Zealand locations and base temperatures between 0 and 20 °C have been prepared by the NZ Meteorological Service (1978). Experience with computer simulations of heating loads has shown that a degree day base temperature of 15 °C is appropriate for typical free heat levels in buildings insulated to comply with NZS 4218P(1979). The ALF (Annual Loss Factor) manual Bassett, Bishop and Van Der Werff (1990) uses degree days to base 15 °C as an indicator of relative climate severity.

The infiltration component of the annual heat requirement can be separately expressed as:

$$E_{\text{inf}} = C_p Q \sum_{\text{hours}} (T_{\text{in}} - T_{\text{out}})$$

Because infiltration is strongly dependent on wind speed the infiltration heat loss can not simply be expressed in terms of heating degree days. This difficulty has been overcome by Sherman (1986a) with a new definition of infiltration degree days that are weighted for high wind areas. The derivation of this new variable is not given here but it is expressed as follows:

$$\text{HIDD} = 1/24 \sum \frac{s}{s_0} (T_{\text{b}} - T_{\text{out}}) \quad \text{for } T_{\text{b}} > T_{\text{out}}$$

The variable  $s/s_0$  is a weighting factor where:

$$s = \sqrt{f_w^2 v^2 + f_s^2 |T_{\text{in}} - T_{\text{out}}|}$$

The average specific infiltration  $s$  has been taken as 0.27 m<sup>3</sup>/hr.cm<sup>2</sup> (used in the USA) and the year total infiltration heat loss is:

$$Q_{\text{inf}} = \rho C_p s_0 L \text{HIDD}$$

$L$  is the normalised leakage which is a function of building airtightness, height and floor area. For times when cooling is required, a cooling infiltration degree day statistic must be calculated. Cooling is considered necessary when the outdoor temperature exceeds 25.4 °C and the specific enthalpy of outdoor air exceeds 65 kJ/kg. There were few

occasions where this cooling requirement was found to apply in the four New Zealand climates listed below in Table 7, hence cooling infiltration degree days are discussed no further.

#### Heating Infiltration Degree Days For New Zealand

Heating infiltration degree days were calculated for Auckland, Wellington Christchurch and Invercargill for 1973 using the Sustep Climate Data files prepared by Leslie and Trethowen (1977). Values for all the variables except  $f_w$  were those specified in the ANSI/ASHRAE draft standard 119P (1987). Minor adjustments to  $f_w$  were made to allow for mast heights and wind exposure of meteorological recording sites in New Zealand.

For comparative purposes, Table 7 shows heating infiltration degree days to base 18.3 °C (65 F) and heating degree days to base 18 °C.

Table 7 Heating and infiltration degree days in New Zealand

Location	Degree Days	
	Heating	Heating Infiltration
Auckland (Mangere)	1151	1220
Wellington (Kelburn)	2054	3461
Christchurch	2424	2193
Invercargill	2573	2416

Heating degree days were similar to infiltration degree days in all locations except Wellington, indicating that the average value of  $s$  was generally similar to the average specific infiltration  $s_0$  chosen to apply in North American climates. For Wellington there were 1.7 times as many infiltration degree days as heating degree days, reflecting higher average wind speeds than in the other three cities. It should be remembered that for buildings in sheltered microclimatic regions in Wellington, the infiltration degree days would be closer to heating degree days.

#### Building airtightness

The proposed ANSI/ASHRAE Standard 119P (1987) defines acceptable levels of building airtightness for climatic zones determined by infiltration degree days. Building leakage areas calculated from airtightness measurements made in New Zealand have been used to calculate normalised leakage areas. These are presented as a histogram in Figure 14 together with acceptable leakage classes. For clarity, Table 8 lists climate expressed in infiltration degree days and corresponding acceptable airtightness levels from ANSI/ASHRAE 119P (1987).

Table 8 Leakage classes and acceptable infiltration degree day totals from proposed ANSI/ASHRAE standard (1987)

Normalised Leakage Range	Leakage class	Acceptable Infiltration degree days
L < 0.10	A	
0.14	A - B	
0.20	A - C	IDD >10000
0.28	A - D	<10000
0.40	A - E	7071
0.57	A - F	5000
0.80	A - G	3536
1.13	A - H	2500
1.16	A - I	1768
L > 1.60	A - J	1250

The intention of the proposed standard has been discussed by Sherman (1986). Here it is pointed out that airtightness criteria were selected to cut off 10 to 20 per cent of the least airtight buildings in the USA to push new construction generally in the direction of improved airtightness. Major improvements in the airtightness of houses in mild climates were considered unnecessary. Although minimum airtightness levels have been set, there are no recommended maximum airtightness levels. Some guidance is given for when an extra source of ventilation might be necessary, which can be summarised as follows. For buildings in classes A-C (2 per cent of NZ houses) infiltration will almost never be sufficient to achieve adequate air quality and some ventilation provision will be necessary. Buildings in classes D-F (87 per cent of NZ houses) will occasionally need mechanical ventilation (i.e. bathroom/kitchen exhaust fans). Buildings in classes G-J (11 per cent of NZ houses) would normally have sufficient infiltration to meet ventilation needs.

## APPENDIX B REFERENCES

American Society of Heating, Refrigerating and Airconditioning Engineers Inc., (ASHRAE) 1987. Proposed American National Standard. Air Leakage Performance for Detached Single-Family Residential Buildings. ANSI/ASHRAE 119P.

Bassett, M. Bishop, R and van der Werff, I. 1990. Annual Loss Factor (ALF) Design Manual. Building Research Association of New Zealand Study Report (to be published). Judgeford.

Leslie, S.F. and Trethowen, H.A. 1977. A Computer File of New Zealand Climate. New Zealand Energy Research and Development Committee Report No.21. Wellington.

New Zealand Meteorological Service. 1978. Average Degree Day Tables Selected New Zealand Stations. Misc. Pub. 159. Wellington.

Sherman Max H. 1986. Infiltration Degree-Days: A Statistic for Quantifying Infiltration-Related Climate. American Society of Heating Refrigerating and Airconditioning Engineers Inc. (ASHRAE) Transactions V.92,Pt. 2.

Sherman, M. 1986a. Exegesis of Proposed ASHRAE Standard 119 : Air Leakage Performance for Detached Single-Family Residential Buildings. BTECC/DOE Symposium on Guidelines for Air Infiltration, Ventilation, and Moisture Transfer, Fort Worth, December 2-4.

Standards Association of New Zealand. 1977. Minimum Thermal Insulation Requirements for Residential Buildings. Wellington. NZS 4218P:1977.

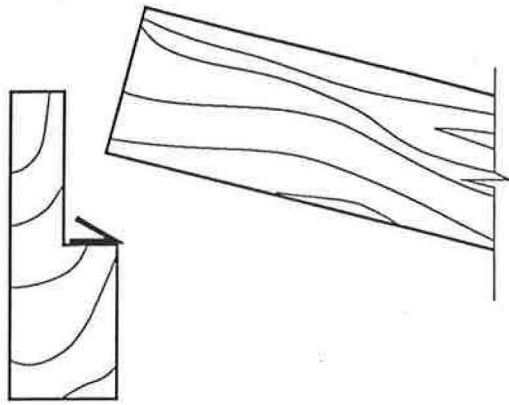

Folded V Strip

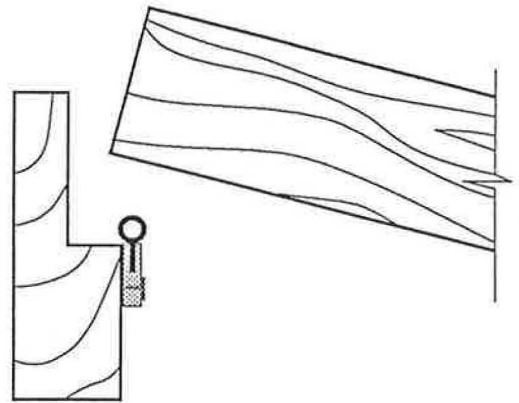

Tubular Strip

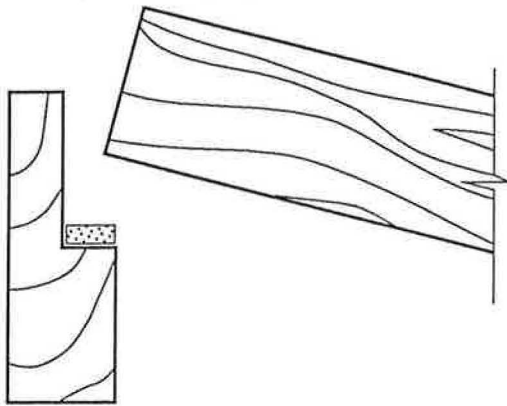

Foam Strip

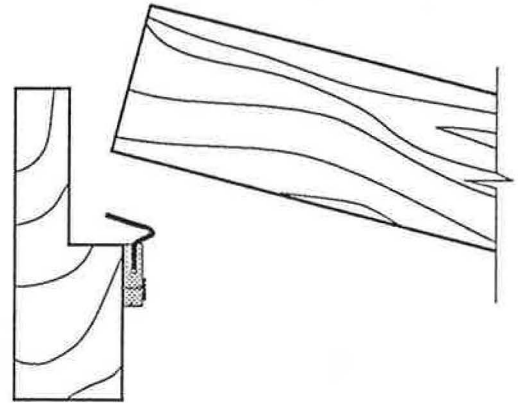

Folded Foam V Strip

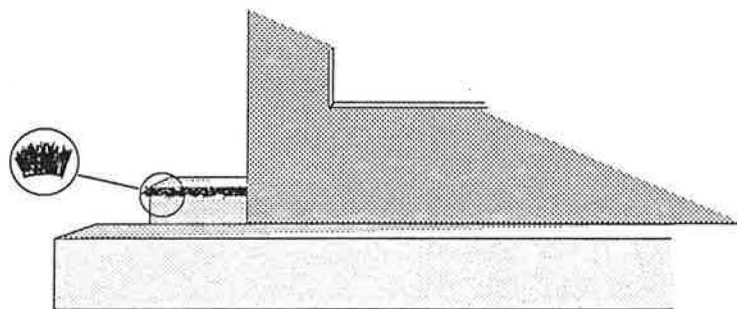

Brush Seal

Figure 1: Generic types of retrofit draughtseals

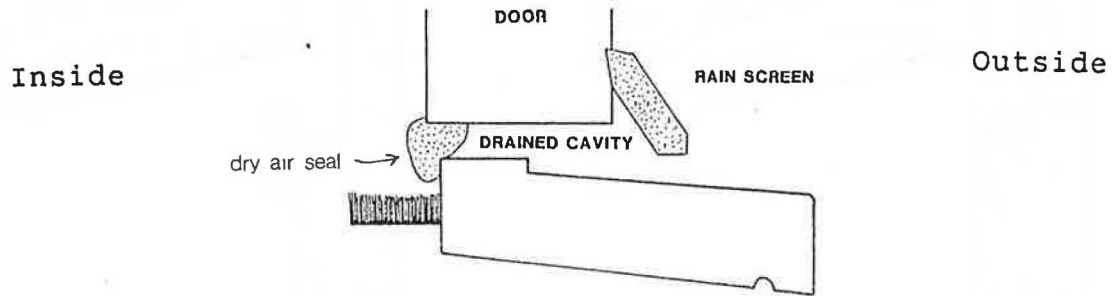

Figure 2: Schematic of threshold seal incorporating separate rain screen, drained cavity and air seal

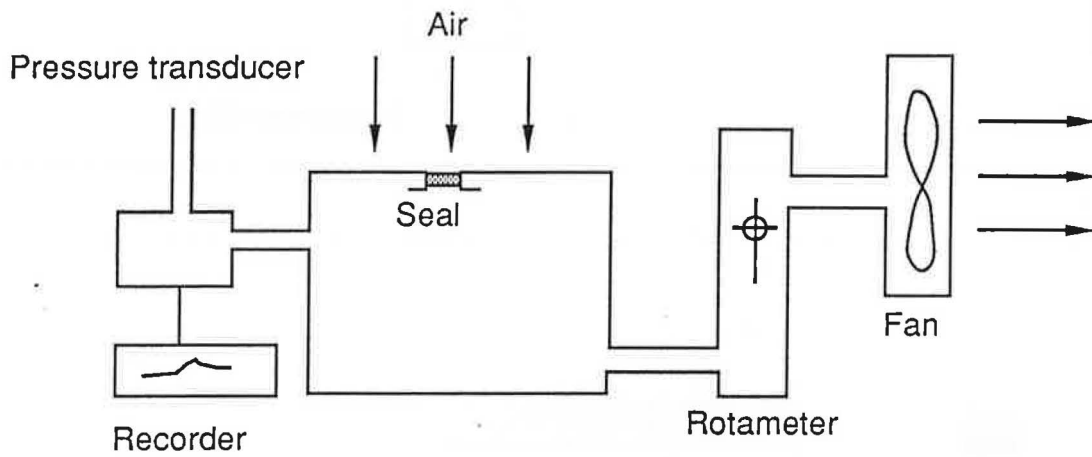
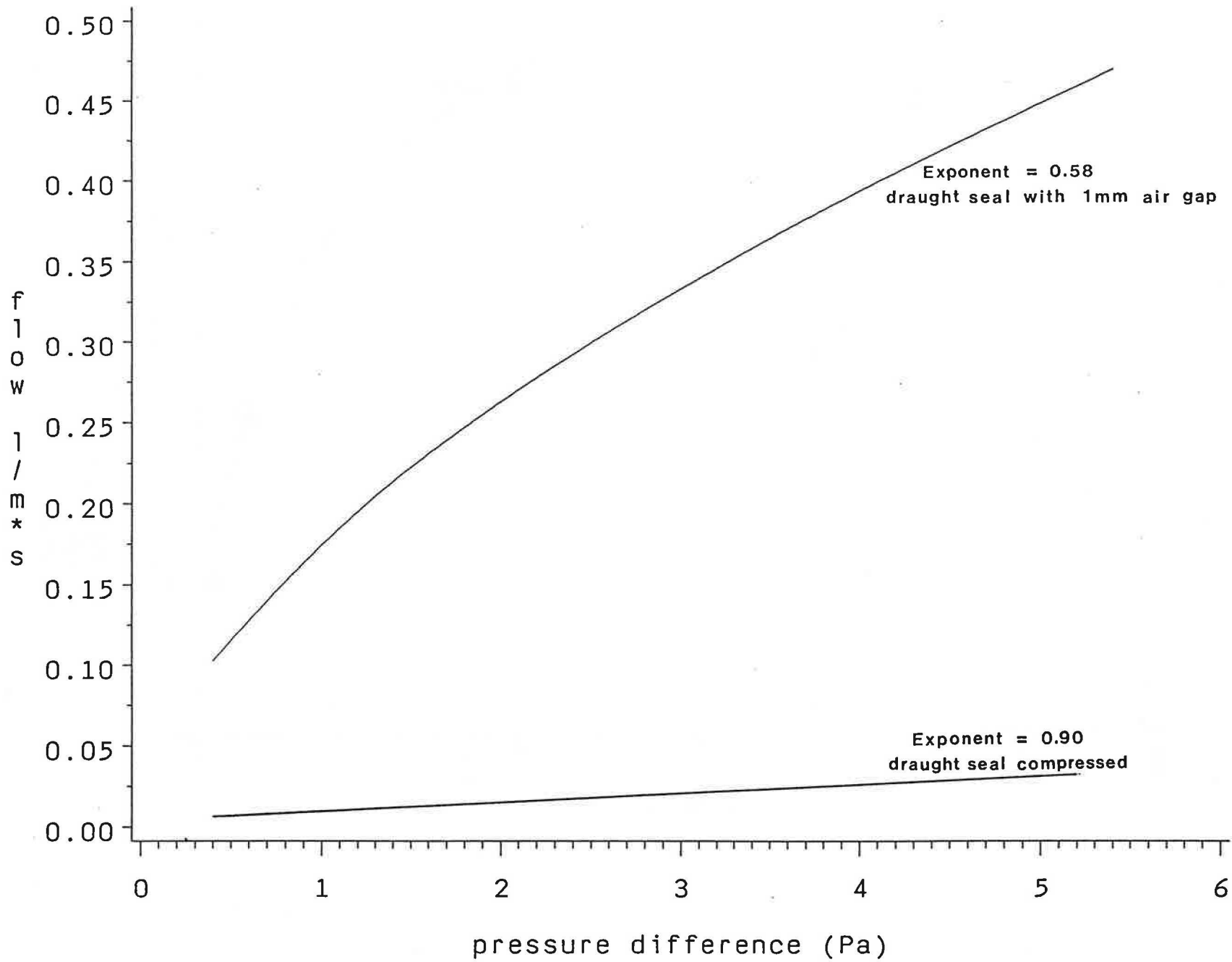

Figure 3: Experimental arrangement for measuring leakage characteristics of draught seals



Figure 4: Air leakage through a draught seal compressed and with an air gap.



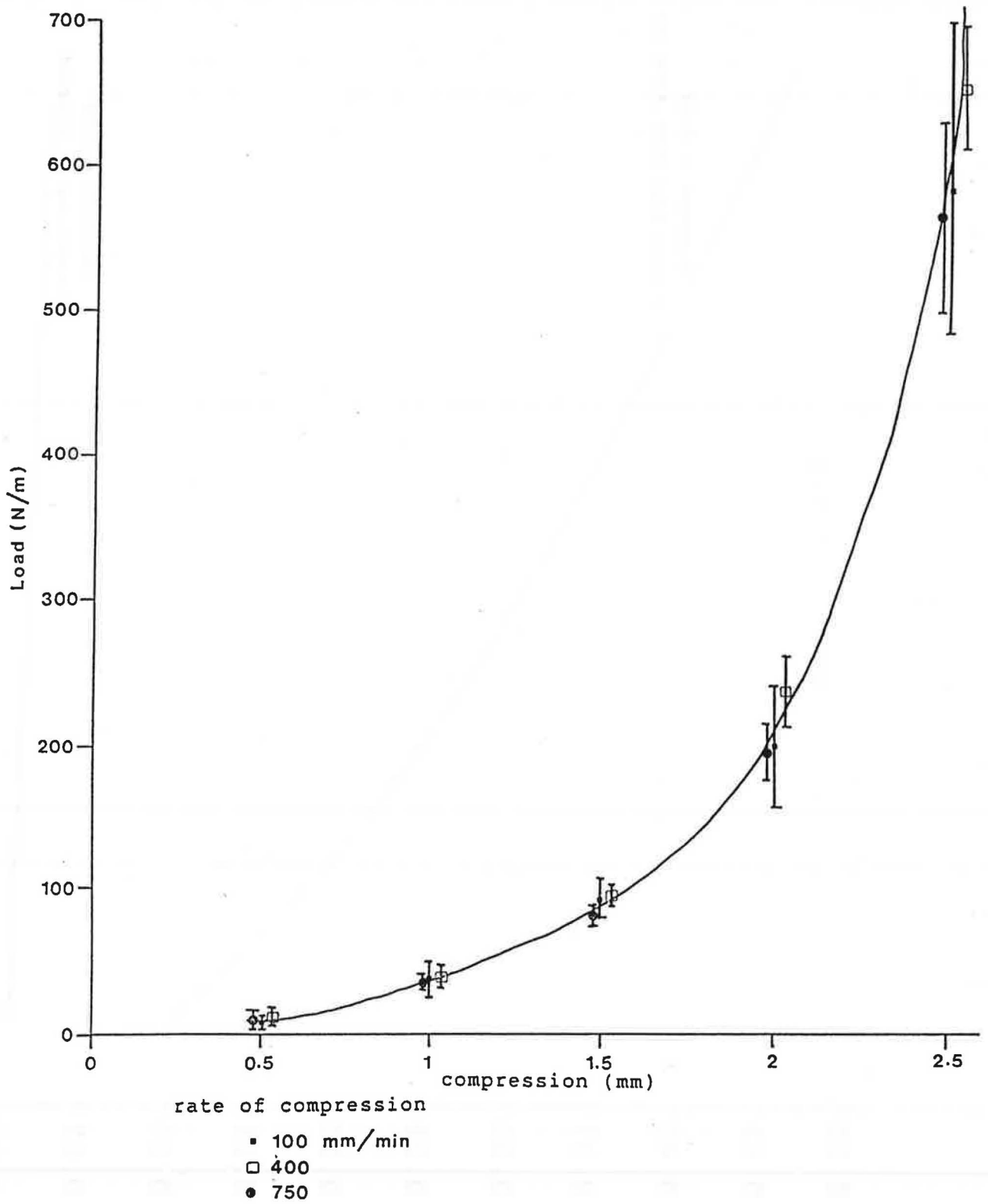

Figure 5: The dependence of compressibility of a foam strip on rate of compression

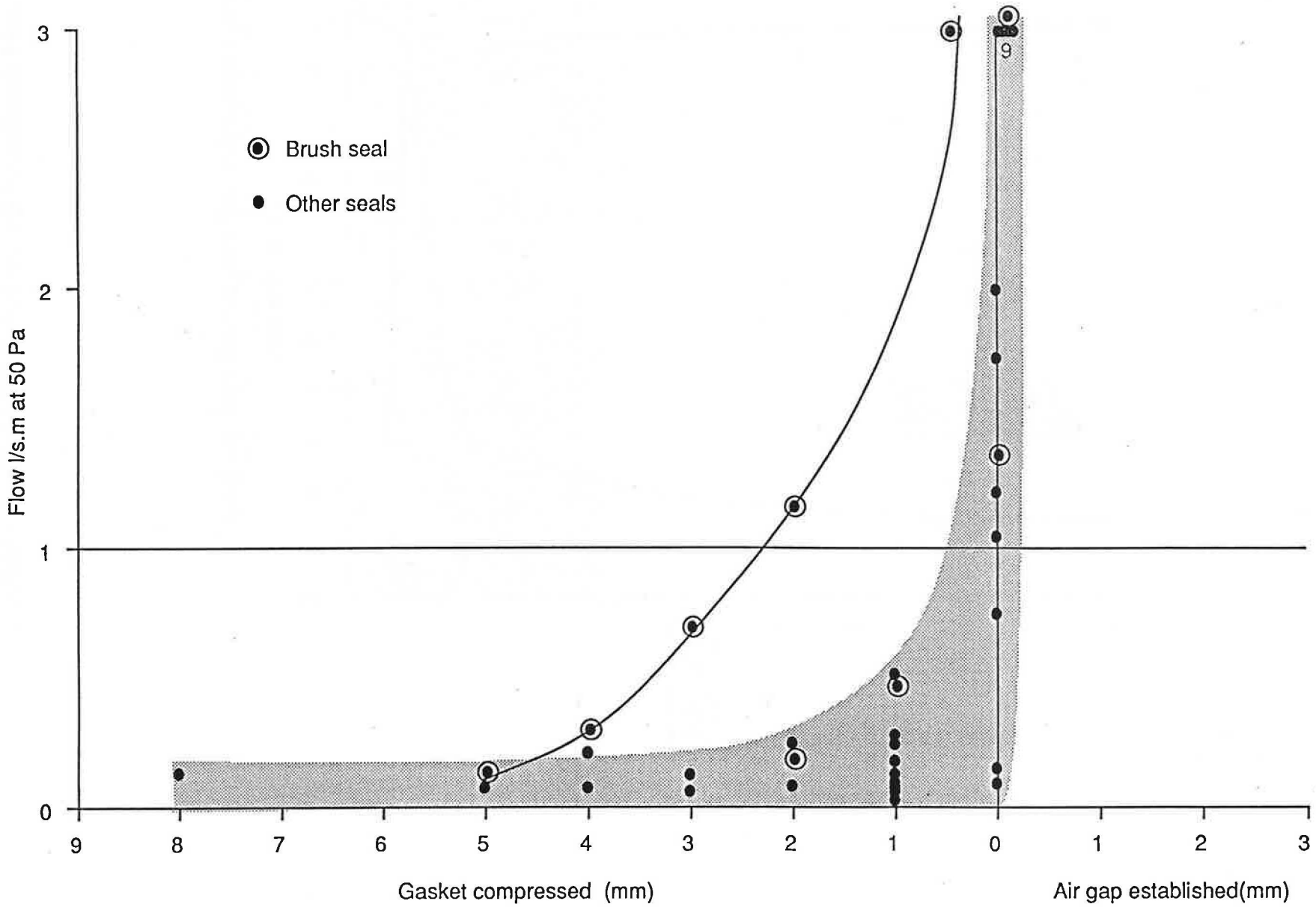

Figure 6 The airtightness of a wide range of draught seals as a function of compression. Shaded area contains most draught seals.

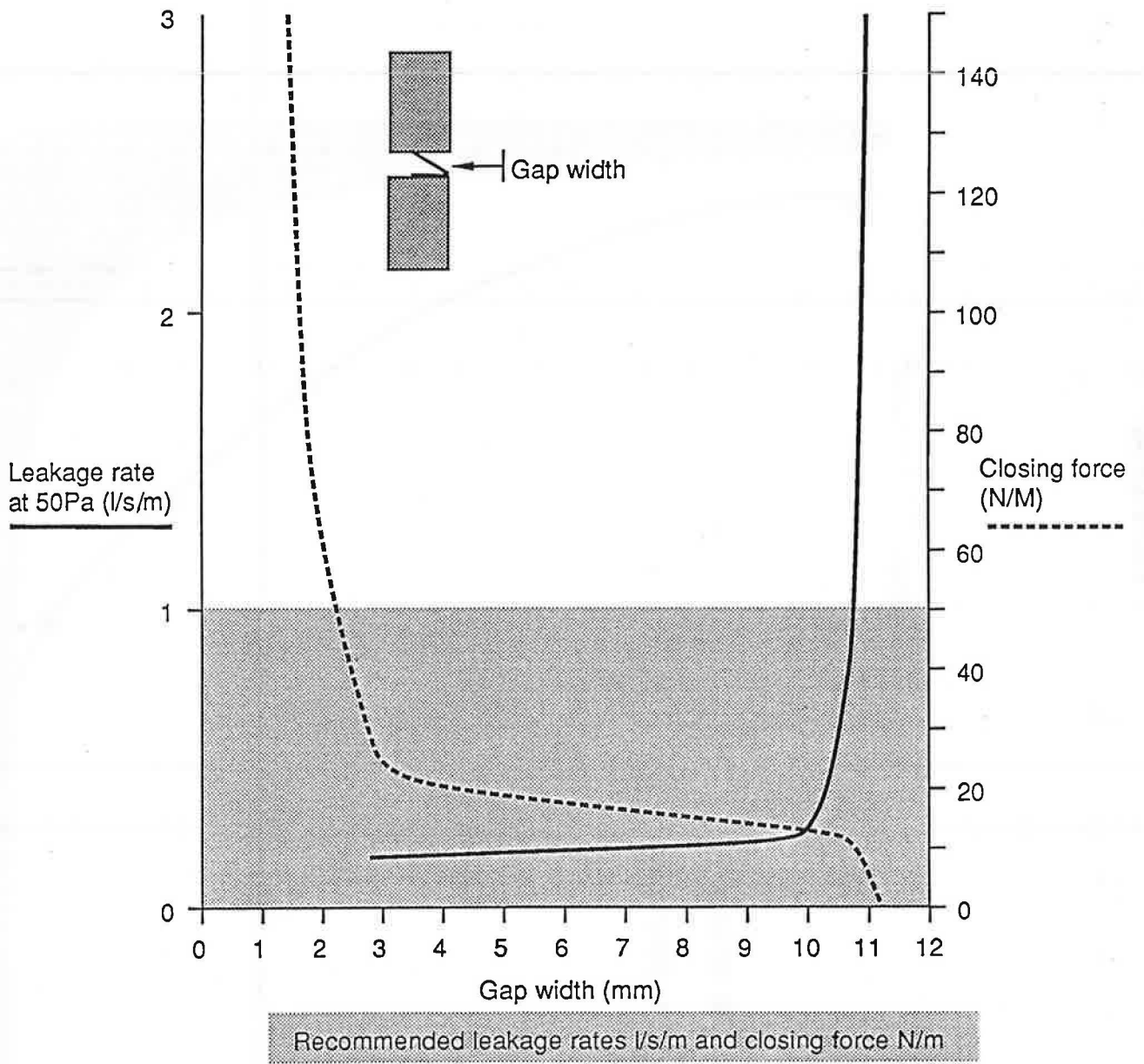
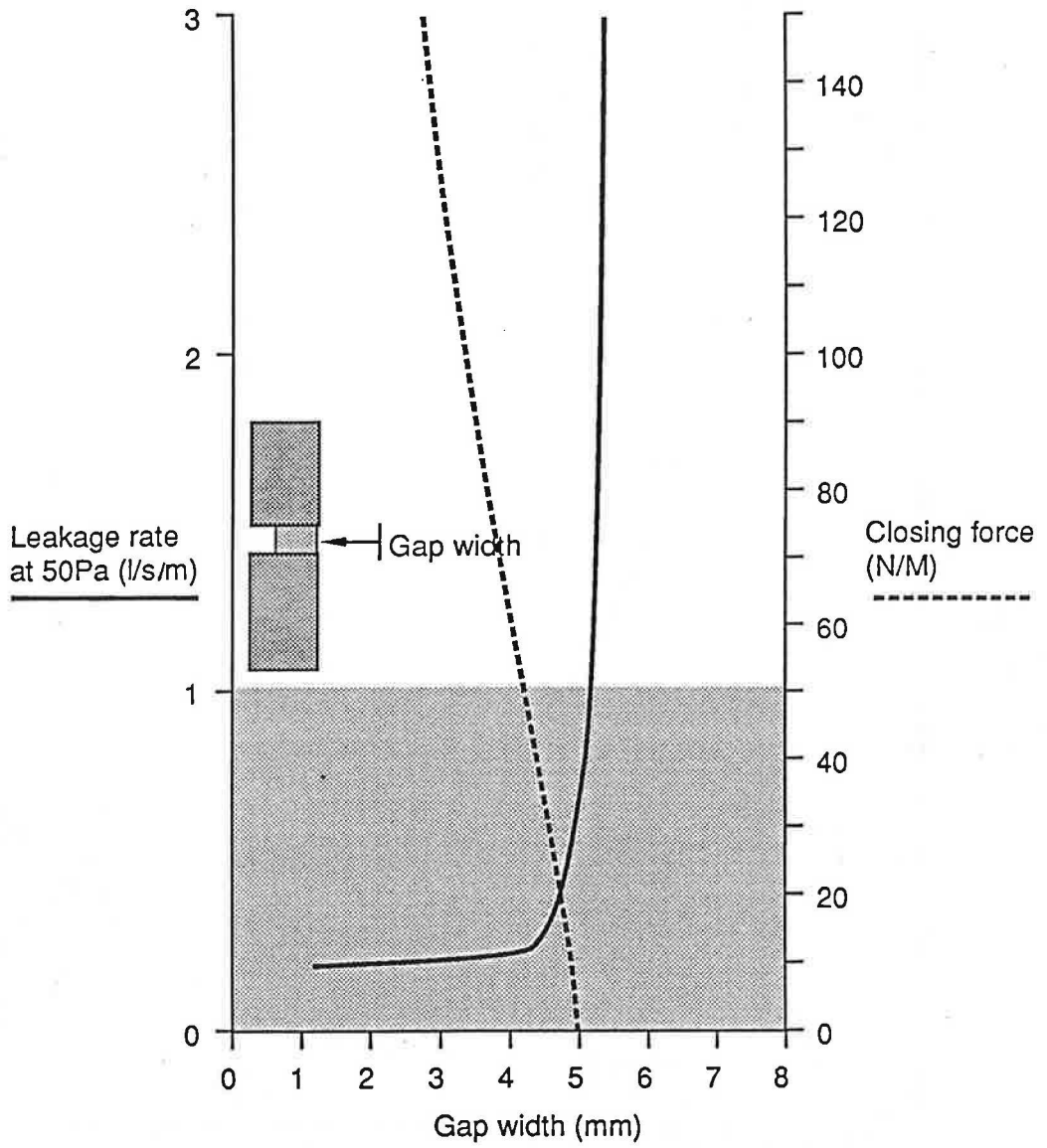
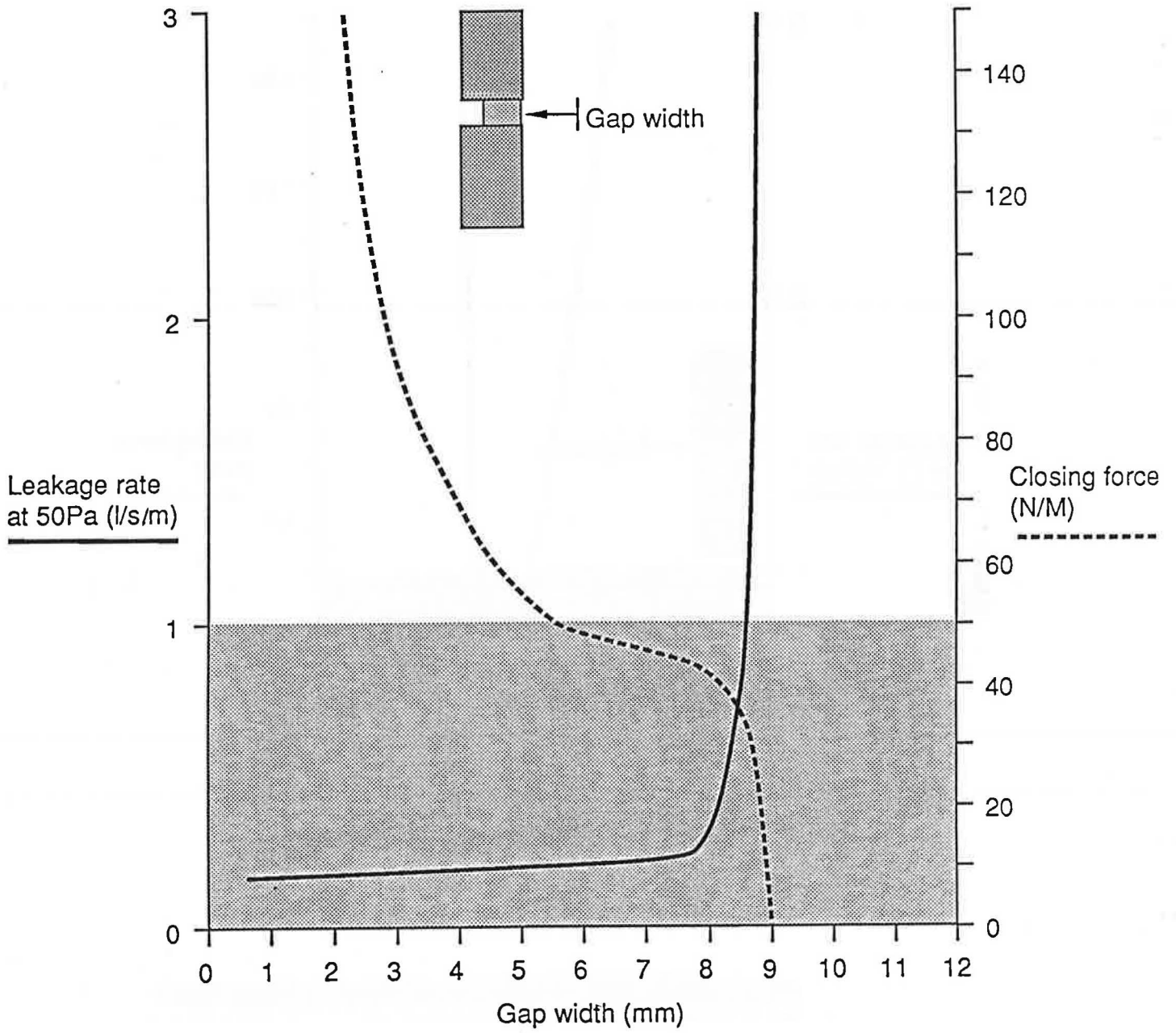

Figure 7 Airtightness and compliance of a V strip (sample 3).



Recommended leakage rates l/s/m and closing force N/m

Figure 8 Airtightness and compliance of a foam strip (sample 7).



Recommended leakage rates l/s/m and closing force N/m

Figure 9 Airtightness and compliance of a foam strip (sample 10)

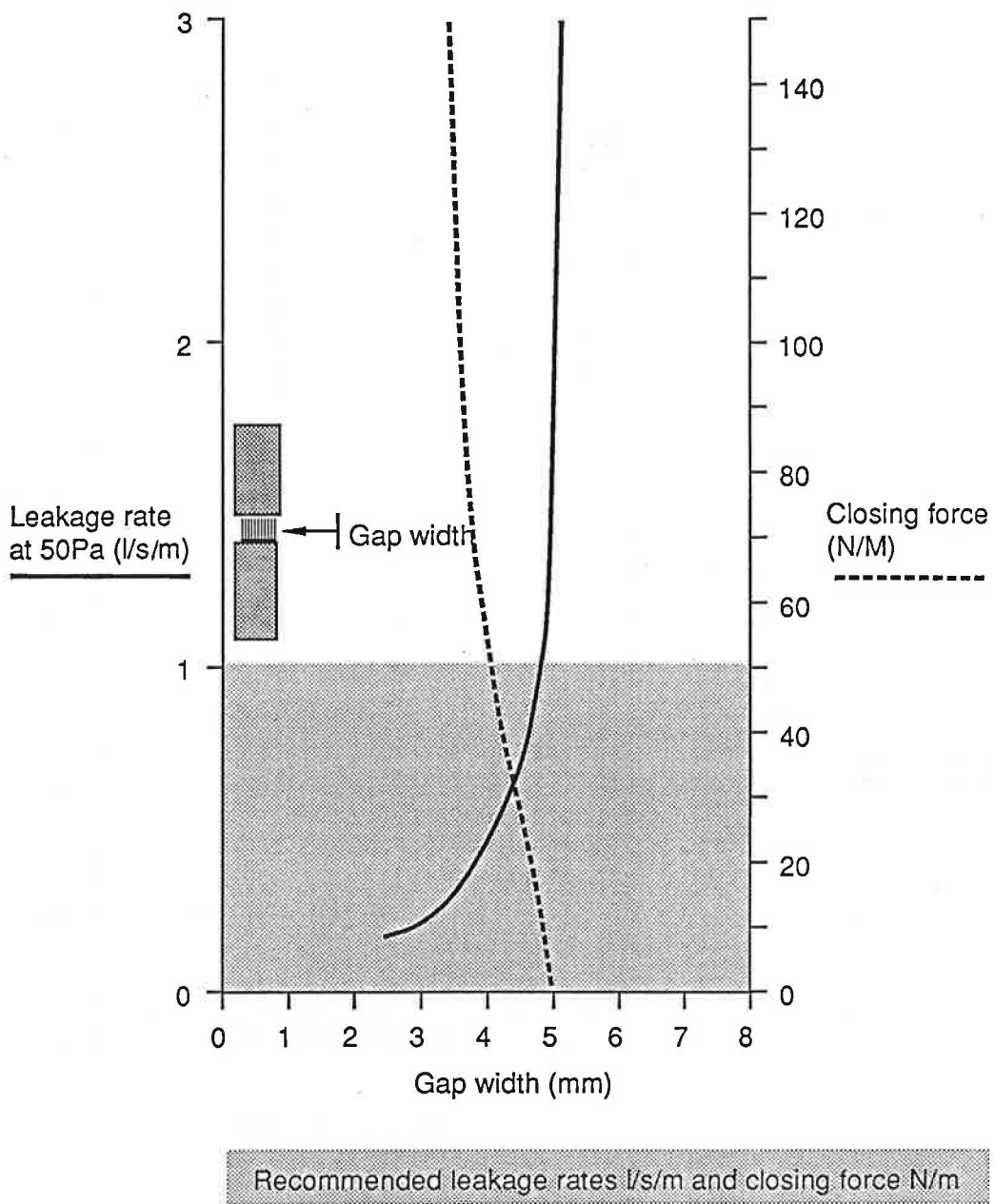

Figure 10 Airtightness and compliance of a brush seal (sample 15).

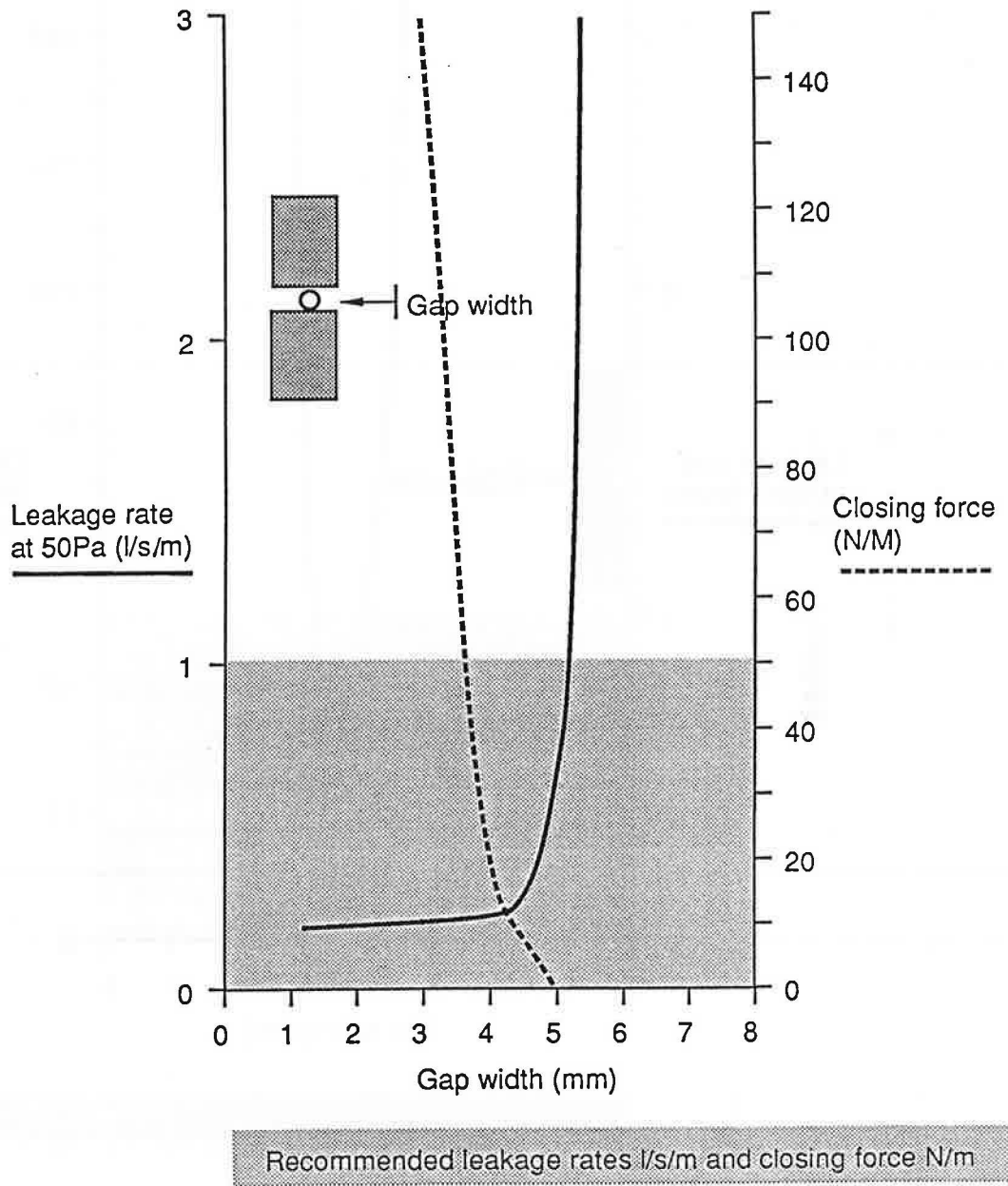

Figure 11 Airtightness and compliance of a tubular strip (sample 19)



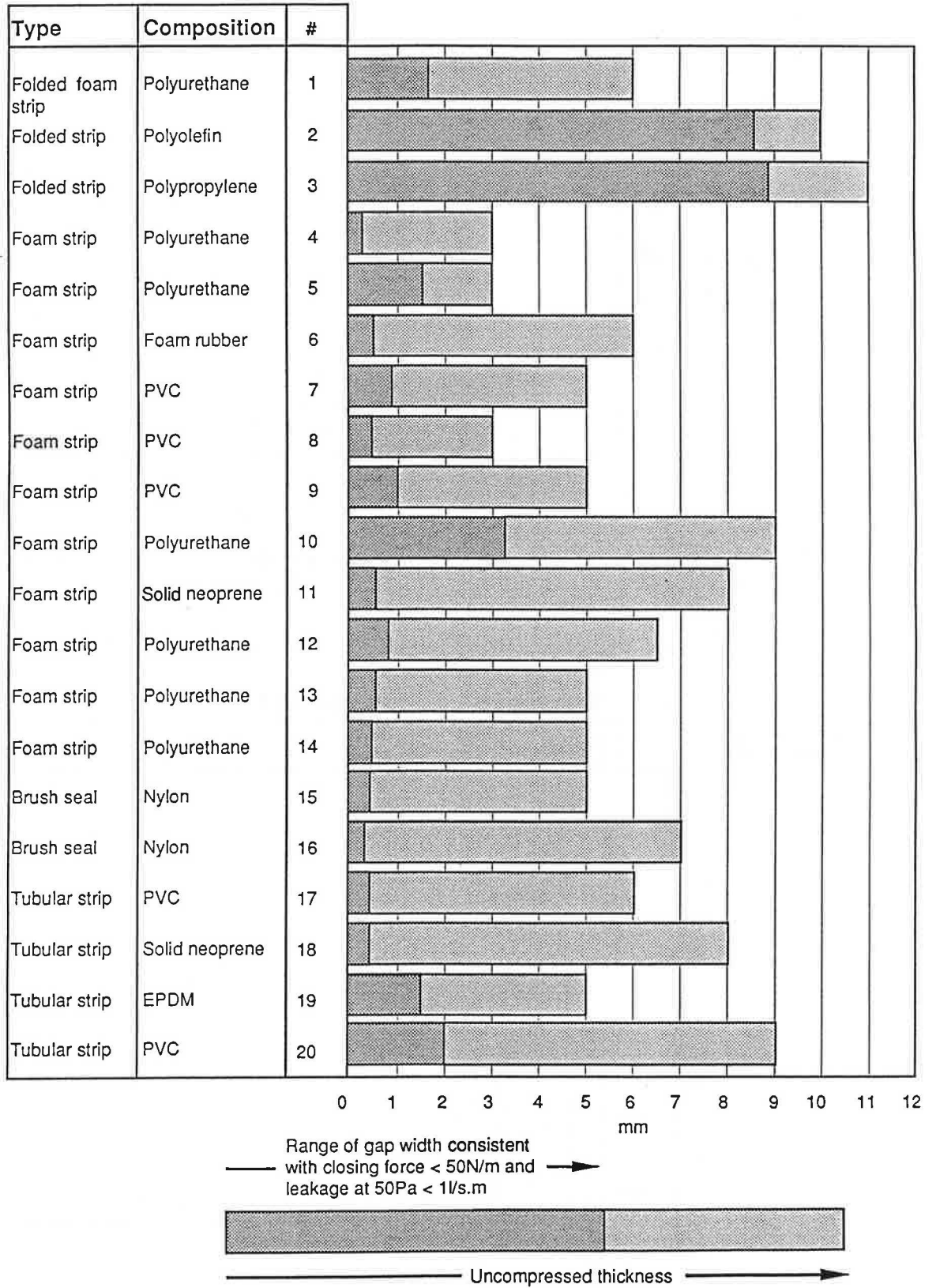

Figure 12 Summary of the working range of draught seals consistent with airtightness and closing force criteria

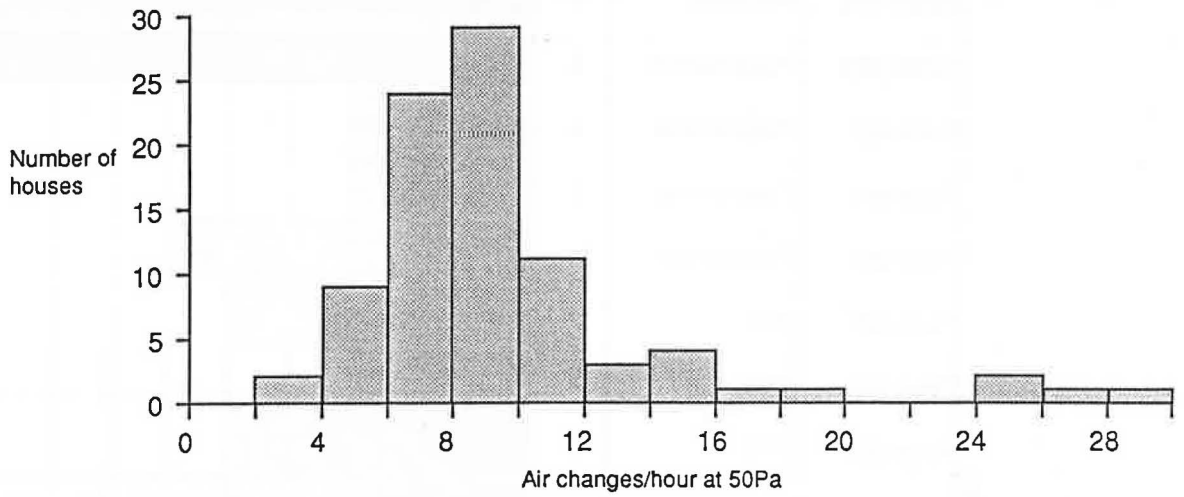

Figure 13: Histogram of airtightness values for New Zealand houses built between 1962 and 1982.

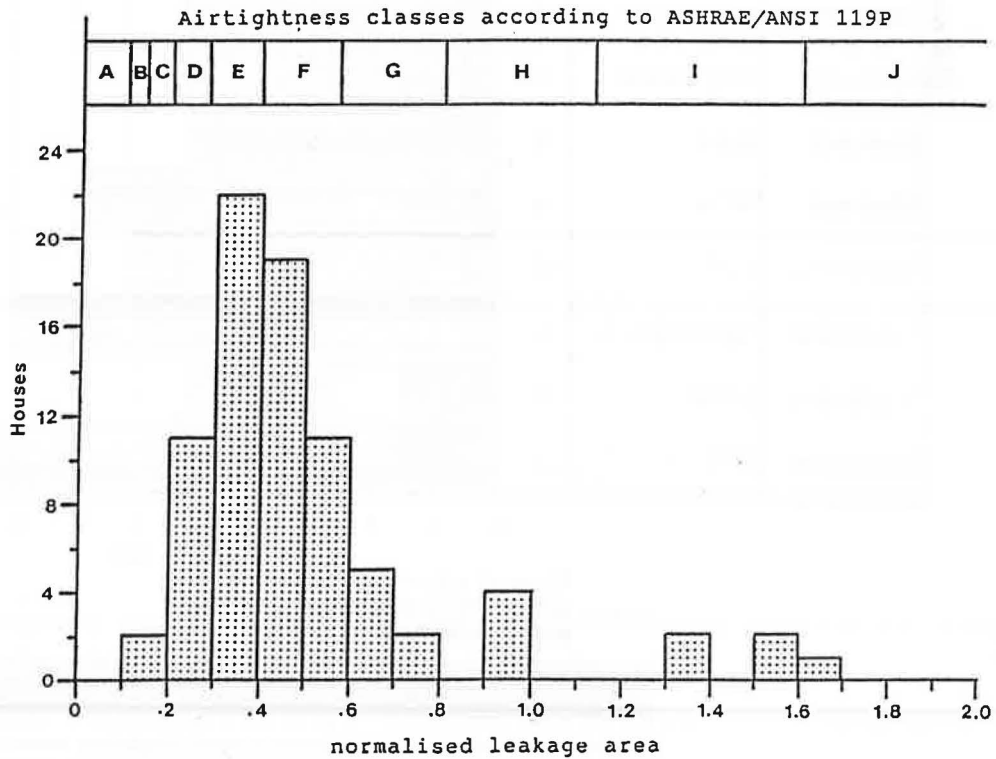

Figure 14: Distribution of normalised leakage areas for NZ houses and leakage classifications.



**BUILDING RESEARCH ASSOCIATION OF NEW ZEALAND INC.  
HEAD OFFICE AND LIBRARY, MCONSHINE ROAD, JUDGEFORD.**

The Building Research Association of New Zealand is an industry-backed, independent research and testing organisation set up to acquire, apply and distribute knowledge about building which will benefit the industry and through it the community at large.

Postal Address: BRANZ, Private Bag, Porirua

