

Low-Cost Home Tips

The Comfort Zone

During cold months, create a warm comfort zone in your home. By heating less space, you can save money.

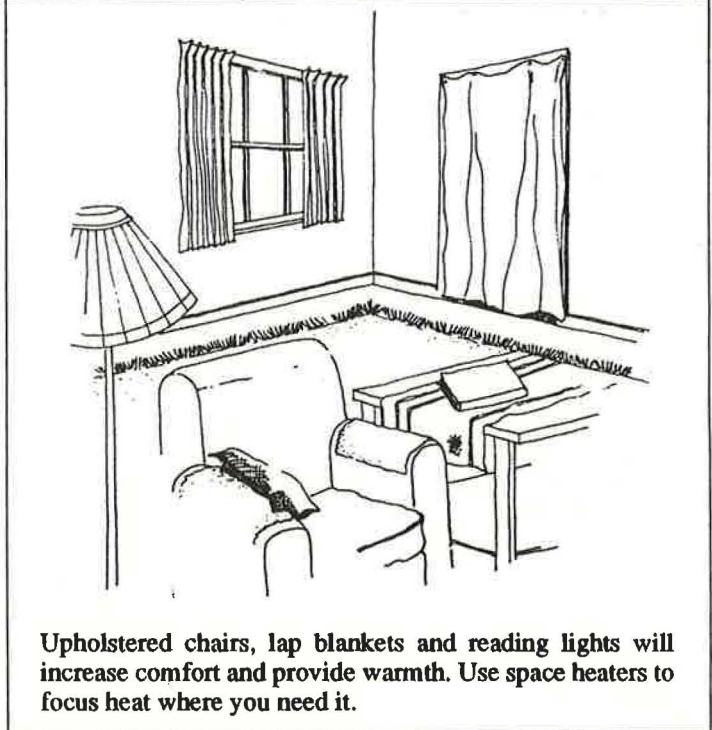
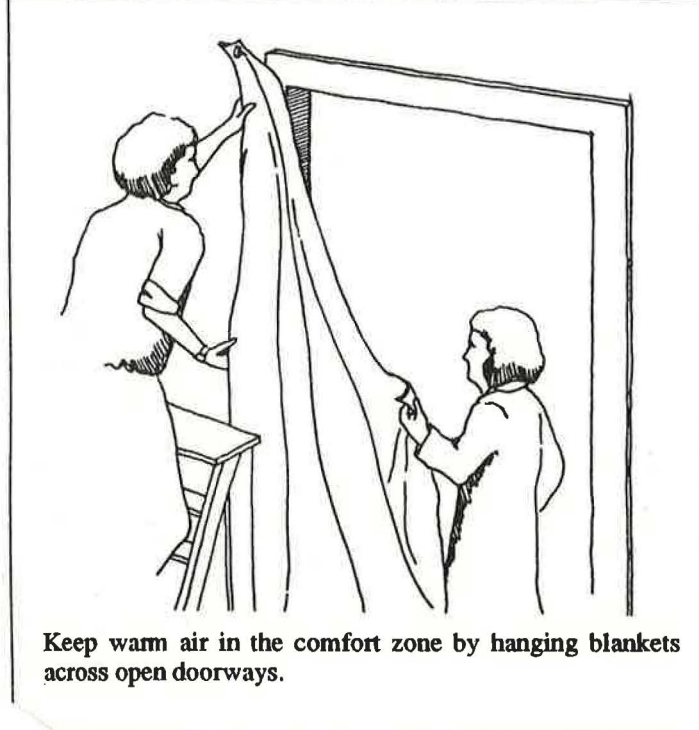
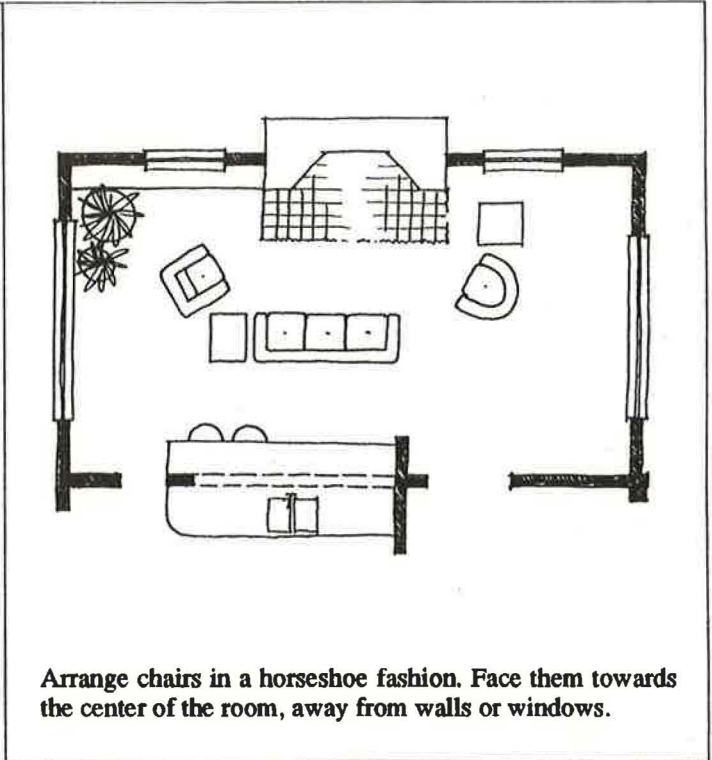
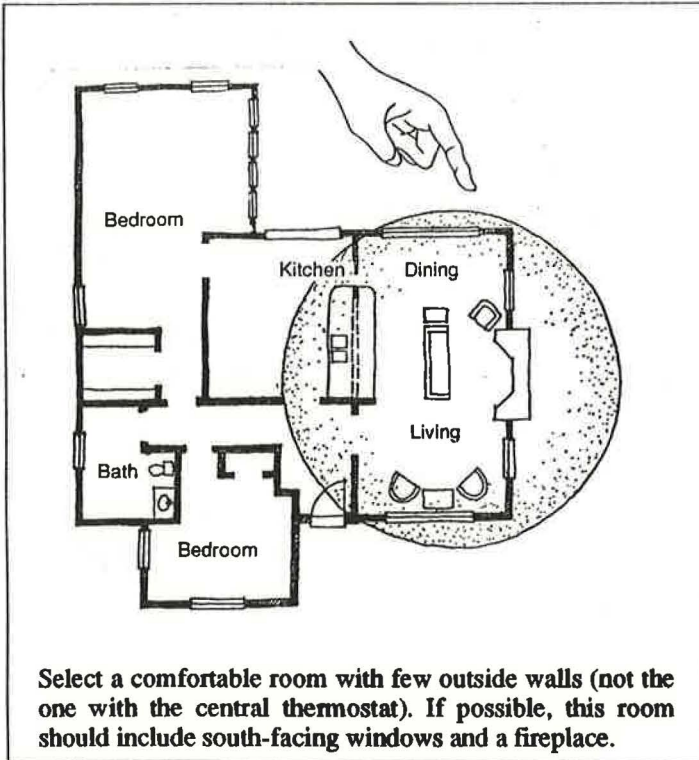

Low-Cost Home Tips

Tape Up Storm Windows

Inexpensive clear plastic used as window covers will reduce drafts, save money, and make your home more comfortable. They're easy to put up.

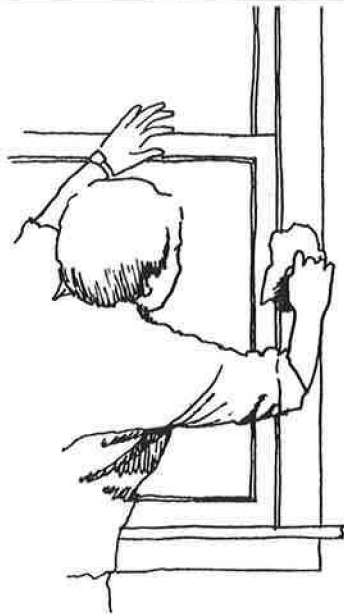

Prepare the window by cleaning the window frame and letting it dry.

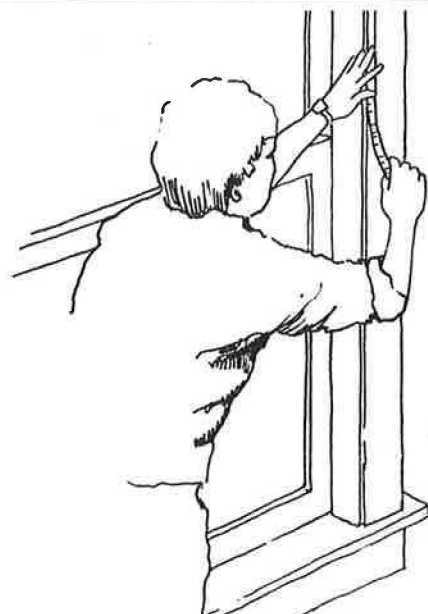

Remove paper backing from one side of double-sided sticky tape. Attach the tape around the four sides of the window frame. Remove paper backing from other side of tape.

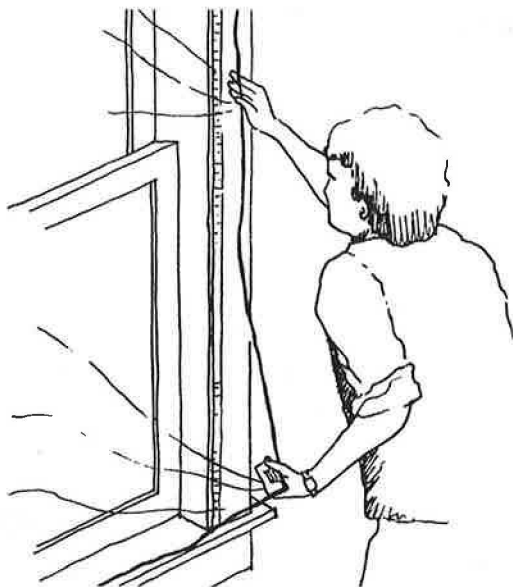

Attach clear plastic squares to the tape, starting with top corner and gently stretching tight while attaching to other three sides.

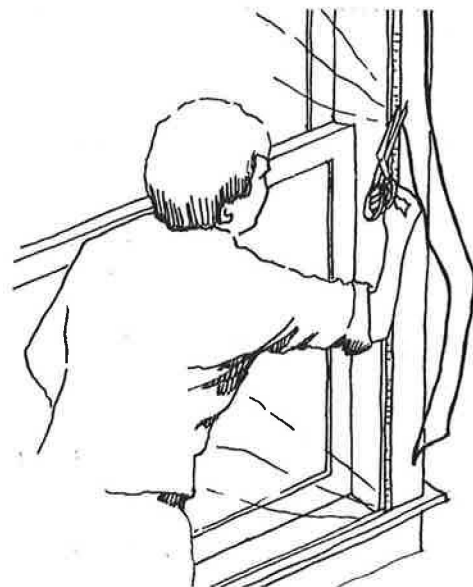

Make sure plastic completely seals the window on all four sides, then trim edges of plastic.

Low-Cost Home Tips

Safety in the Warm Room

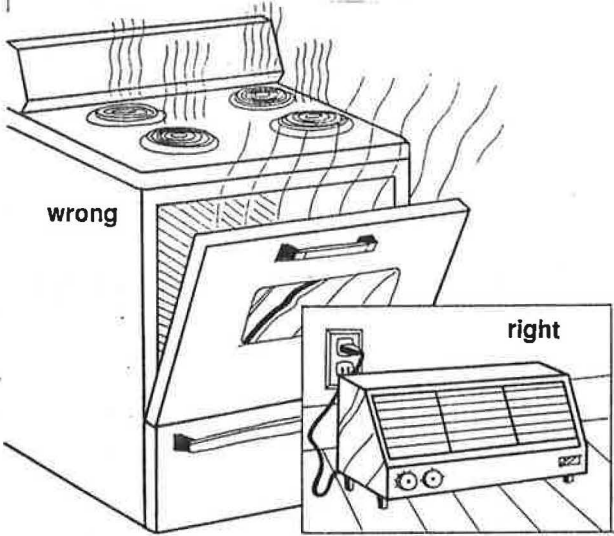

wrong

right

It's unsafe to heat rooms with the range or oven. Use a small space heater instead. Use space heaters safely.

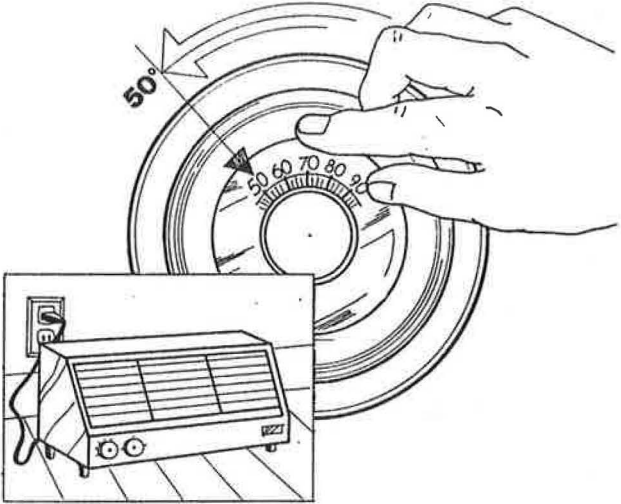

50°

50 60 70 80 90

Set back the furnace thermostat and keep warm with a space heater. Prevent freezing pipes by maintaining room temperatures at 45 degrees F or greater. Seniors should take precautions against hypothermia.

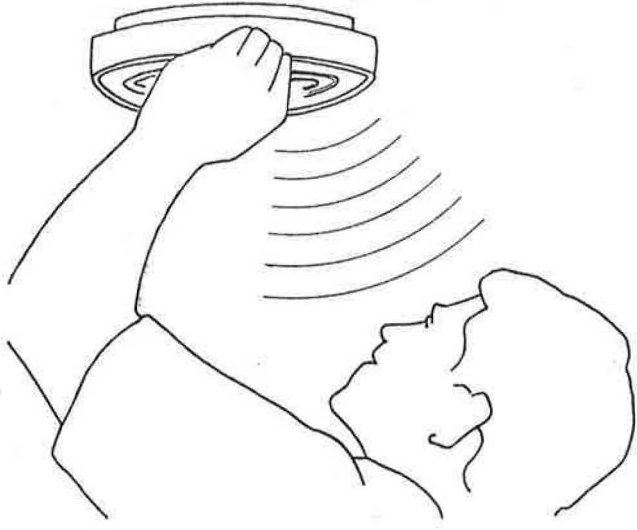

Check smoke detectors monthly to make sure they're working.



Use a metal fireplace cover to reduce heat loss up the chimney.

Low-Cost Home Tips

Reducing Drafts For Winter

Reduce cold air drafts by plugging cold air leaks on the inside of the house. Inexpensive materials can be used.

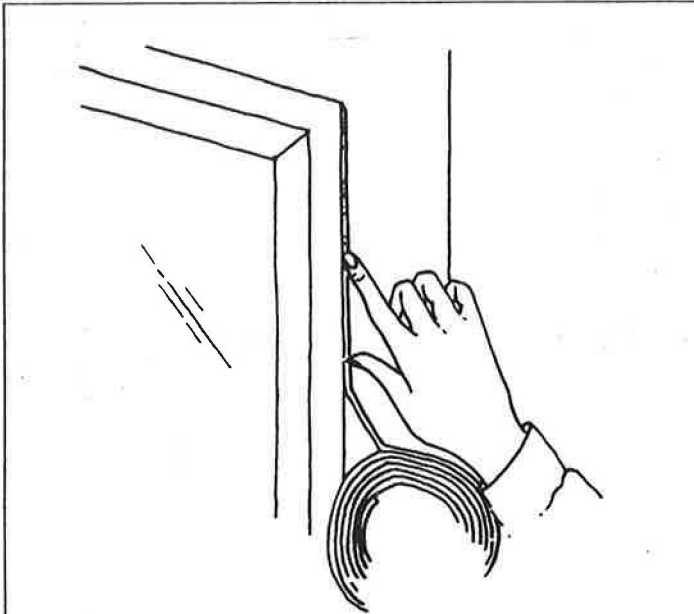

Rope caulk is cheap, available at hardware stores and goes on easily. Press in place around windows and door frames. It peels off easily and leaves no marks.

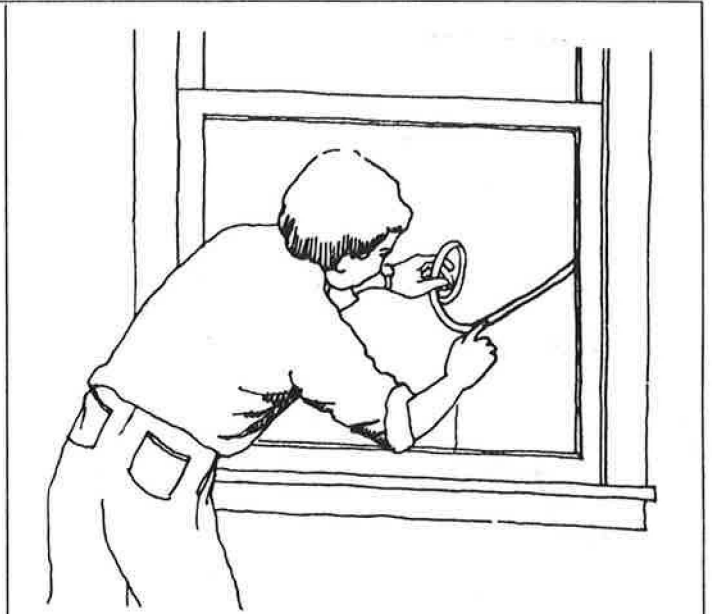

Cracked window seals can be resealed with masking or weatherstripping tape.

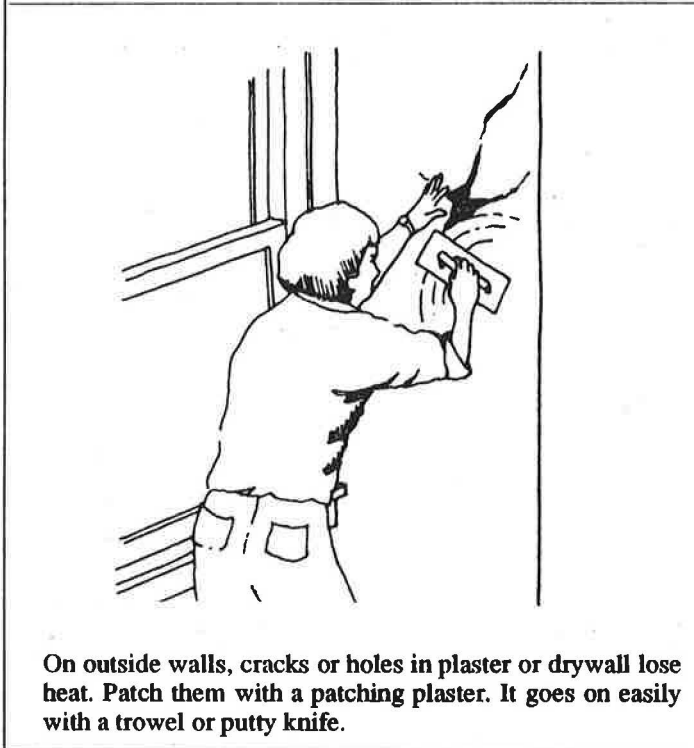

On outside walls, cracks or holes in plaster or drywall lose heat. Patch them with a patching plaster. It goes on easily with a trowel or putty knife.

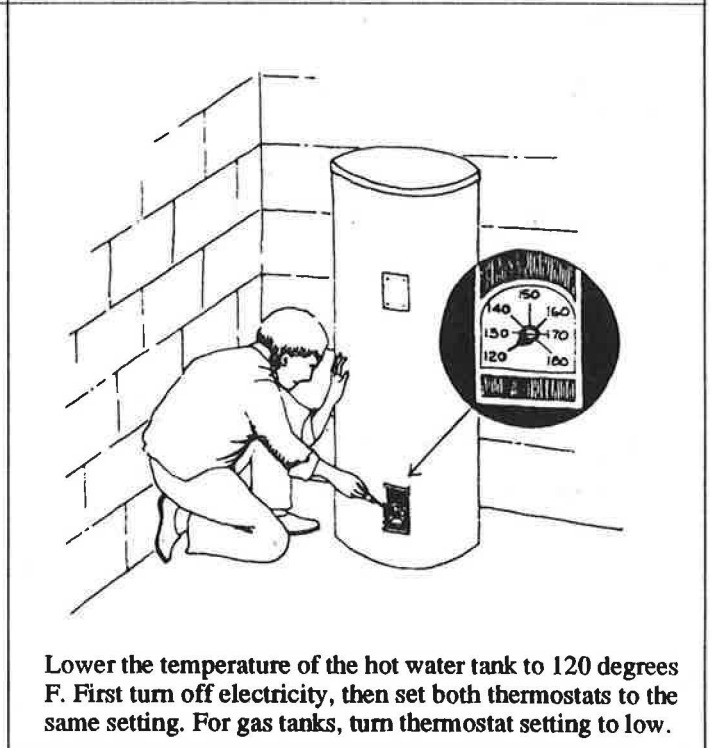

Lower the temperature of the hot water tank to 120 degrees F. First turn off electricity, then set both thermostats to the same setting. For gas tanks, turn thermostat setting to low.

Low-Cost Home Tips

One Minute Warm-Up

Here are four quick and easy steps that that will reduce cold drafts in your home and save you money.

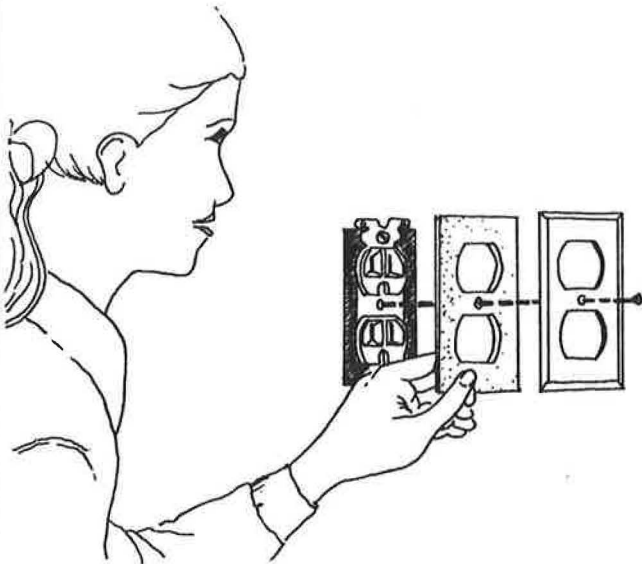

Install foam gaskets behind the face plates of electric outlets and switch plates. Turn off electricity before installing.



To stop cold drafts under doors, make door snakes by sewing scrap cloth into cloth tubes. Place them against the bottom of doors.

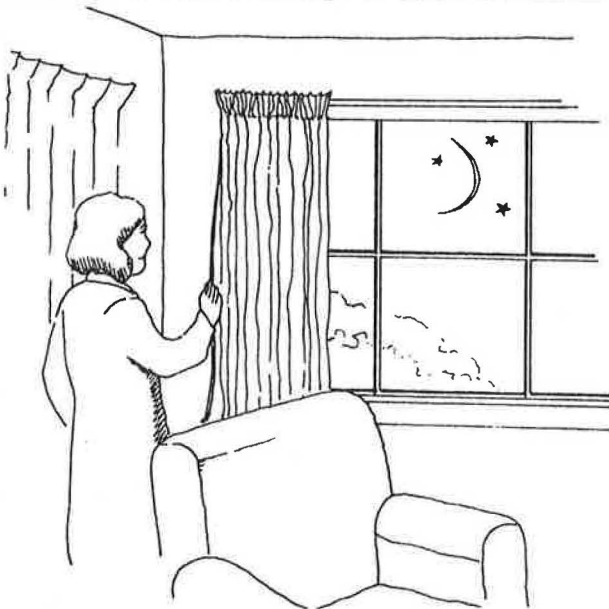

Close drapes at night and open them in the morning.

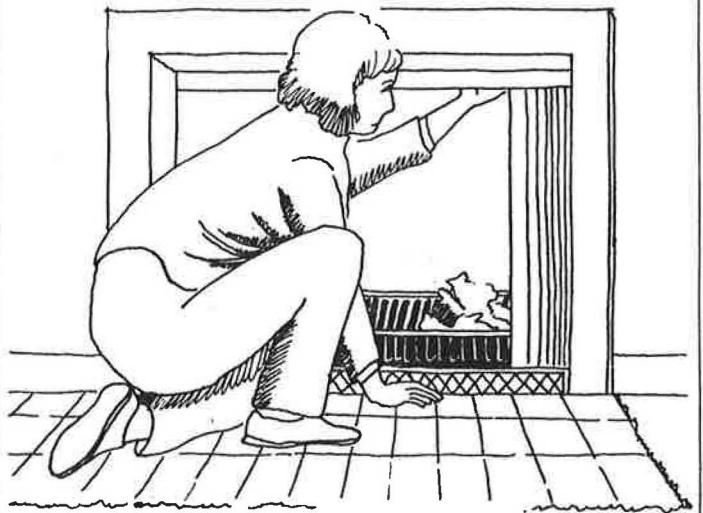

Close the fireplace damper when the fireplace is not in use and after coals are cold.

Low-Cost Home Tips

Keeping Warm With Wood

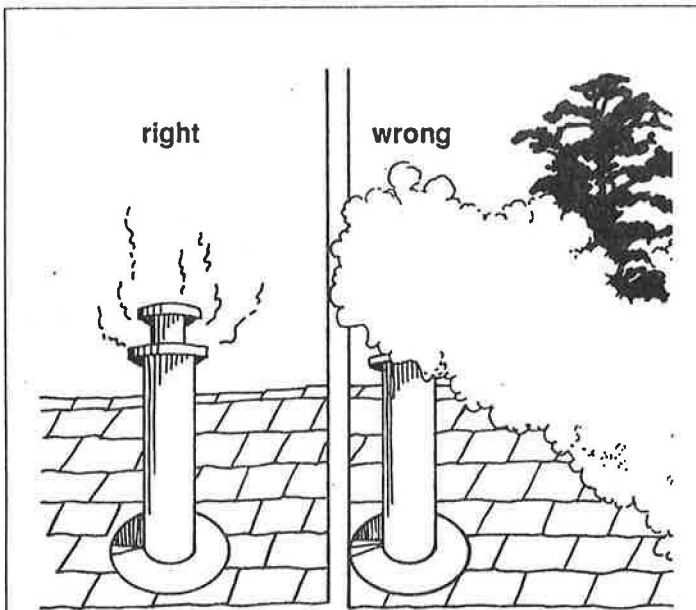

Check the chimney. If it's too smoky, open air inlets and stove dampers, or increase temperature of catalytic combustor.

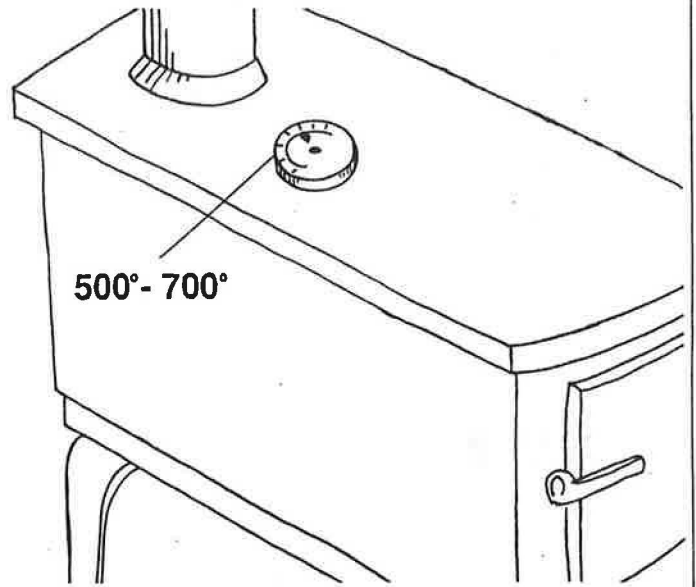

Use a stove thermometer. Keep the stove surface temperature (or the catalytic combustor) at 500 degrees F to 700 degrees F.



Telephone Hotline
1-800-523-INFO
or stay tuned to your
TV, Radio, or Newspapers

Update

Wood-stove heating banned

The Associated Press

Restrictions on burning are in effect until at least this afternoon in King, Pierce, Kitsap and Snohomish counties because of weather conditions trapping smoke near the ground.

Boyd Knechtel, chief of technical services for the Puget Sound Air Pollution Control Agency, said the ban affecting wood stoves, fireplaces and outside burning went into effect at 2:30 p.m. yesterday.

Under the regulations, burning in wood stoves and fireplaces is prohibited unless the stove is certified under state regulations or the appliance is the only form of heat in the home. All outdoor burning is banned.

Recorded messages regarding the restrictions are available by dialing 296-5309 in the Seattle area and toll-free 1-800-433-2213 elsewhere.

Wood-burning ban discontinued

Restrictions on wood burning were lifted in the Seattle area yesterday afternoon.

An "episode of impaired air quality" had been declared Thursday afternoon by the Puget Sound Air Pollution Control Agency in King, Pierce, Snohomish and Kitsap counties.

The restrictions were lifted because winds had scrubbed pollutants from the region.

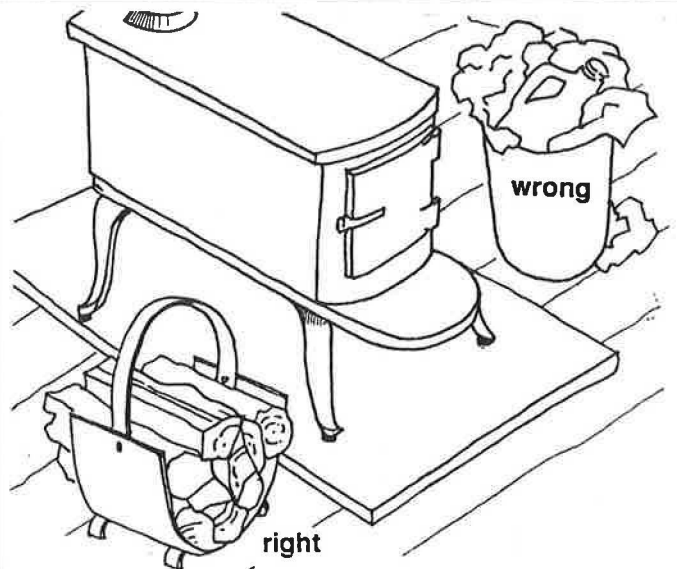

During burning bans, use your back-up source of heat rather than firewood. Find out about burning bans from the news media, or call the wood smoke hotline.

Use well-seasoned wood. Don't burn trash, painted or treated woods.

Low-Cost Home Tips

Warm Up Patio Glass Doors

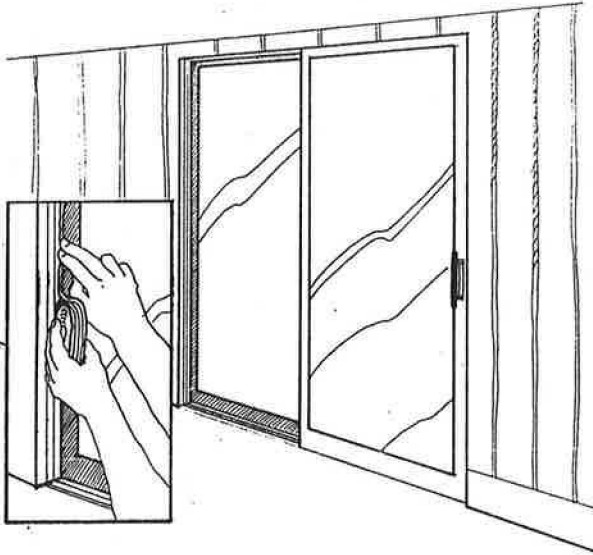

Use rope caulk to seal air leaks around patio doors.

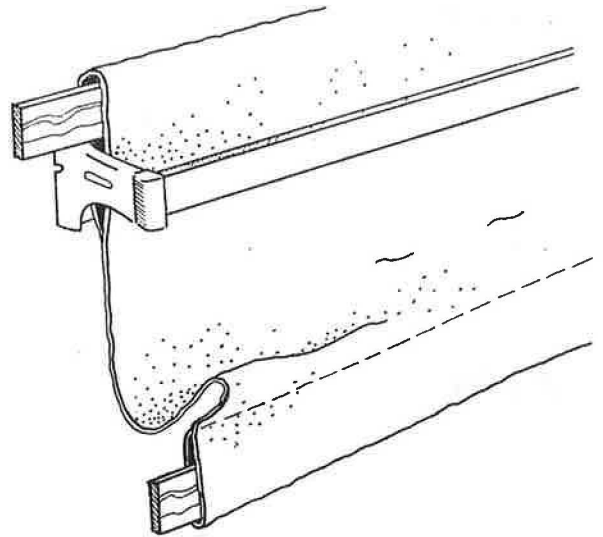

Warm up the patio door area by hanging a blanket from a wooden rod, or...

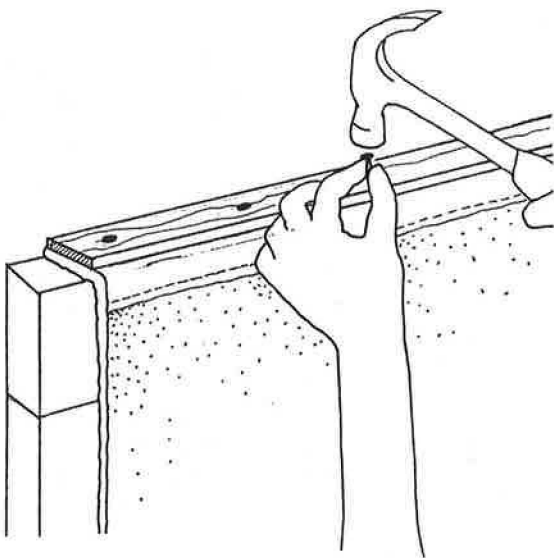

Hang a blanket using tacks across the top of the patio door, or...

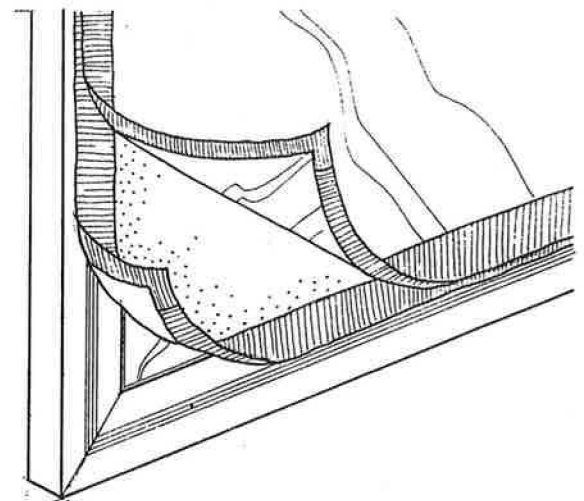

Tape a blanket on all four sides to the patio door and cover the blanket with a sheet of plastic.