

#3912

INSTITUTTET FOR BYGNINGSTEKNIK
DEPT. OF BUILDING TECHNOLOGY AND STRUCTURAL ENGINEERING
AALBORG UNIVERSITETSCENTER • AUC • AALBORG • DANMARK

23.5

INDOOR ENVIRONMENTAL TECHNOLOGY
PAPER NO. 12

To be presented at the Second International Conference ROOMVENT '90,
Oslo, June 13-15, 1990

M. SKOVGAARD, C. E. HYLDGAARD & P. V. NIELSEN
HIGH AND LOW REYNOLDS NUMBER MEASUREMENTS IN A
ROOM WITH AN IMPINGING ISOTHERMAL JET
APRIL 1990 **ISSN 0902-7513 R9003**

**"HIGH AND LOW REYNOLDS NUMBER MEASUREMENTS IN A ROOM
WITH AN IMPINGING ISOTHERMAL JET."**

M. Skovgaard, C. E. Hyldgaard, and P. V. Nielsen.

University of Aalborg.
Aalborg, Denmark.

Summary.

The present paper, which is within the work of the IEA - annex 20, presents a series of full scale velocity measurements in a room with isothermal mixing ventilation. The measurements is in the Reynolds number range 1000 - 7000 based on inlet dimensions. This means that a transition from laminar to turbulent flow is occurring.

The measurements, which have been carried out are : measurements of the change in effective inlet area, wall jet measurements (both cartesian and radial approach), measurements of mean velocities and rms values in the occupied zone and measurements of low Reynolds number effects.

Further, all measurements are made at different air change rates The velocity profiles have been normalized and it is analysed if the measured velocity distribution can be represented as a wall jet. An extensive analysis of the the low Reynolds number phenomenon is made.

Nomenclature.

a	Area.	[m ²]
c	Constant for determination of velocity in the occupied zone.	
D	Constant in growth of jet width.	
f ₁ ^a	Function for determination of velocity in occupied zone.	
K	Function i the radial wall jet decay.	
K ^a	Constant in the decay of a wall jet.	
K ₁ ^a	Function in the decay of a radial impinging jet	
L	Length of the room.	[m]
n	Air change rate.	[h ⁻¹]
r	Radius	[m]
Re	Reynolds number.	
u	Velocity.	[m/s]
x	Distance from inlet wall.	[m]
x ^o	Distance to virtual origin.	[m]
y	Distance from floor.	[m]

Subscripts :

d	Diameter of nozzle in the inlet device.
o	Inlet, effective.
rm	Maximum in the occupied zone
r	Maximum in radial direction.
x	Maximum in x - direction.

Greek :

ϕ	Angle in the (x,y) - plane.
ϑ	Angle in the radial direction.
δ	Width of wall jet.
ν	Kinematic viscosity.

1. Introduction.

Calculation and dimensioning of mixing ventilation systems is traditionally made by a number of simplified models, *Nielsen* [1]. The models are based on the theory of the three dimensional wall jet, because large parts of the air distribution can often be described by this type of flow. Measurement has been done by different authors and additional measurements is reported in this paper. In the simplified models the throw and penetration depth of the jet are the important parameters for determination of the maximum velocity in the occupied zone.

The decay of the center line velocity in a three - dimensional jet is given by *Nielsen* [1], [13]

$$\frac{u_x}{u_o} = K_a \frac{\sqrt{a_o}}{x + x_o} \quad (1)$$

and the maximum velocity in the occupied zone is given by *Nielsen* [1] for three dimensional flow and in [9] for two dimensional flow. For three dimensional flow :

$$u_{rm} = u_o f_1 K_a \frac{\sqrt{a_o}}{x + x_o} \quad (2)$$

It is possible to incorporate a possible Reynolds number effect in this model by taking the change in a_o , K_a and f_1 into account. However in most cases this is not done and, as it will be seen, disregarding e.g. the variation in a_o , can be quite significant. Equation (1) can be used for values in the mean plane. The flow outside the symmetry plane will often have some radial component. This can be described as done by *Beltaas* [2]. The inlet flow is regarded as a radial impinging jet and *Beltaas* [2] found the following expression

$$\frac{u_r}{u_o} = K_1(\phi, \vartheta) \frac{d}{r} \quad (3)$$

$$K_1(\phi, \vartheta) = \frac{1.1}{\sqrt{\sin\phi}} \frac{1 + \cos\phi \cos\vartheta}{\cos^2\vartheta + \left[\frac{\sin\vartheta}{\cos\phi} \right]^2} \quad (4)$$

In order to incorporate the virtual origin and the effective inlet area the following approach is used

$$\frac{u_r}{u_o} = K(\phi, \vartheta) \frac{\sqrt{a_o}}{r + x_o} \quad (5)$$

The three dimensional wall jet eq. (1) is identical to the radial approach for $\vartheta = 0$ and constant ϕ .

An alternative and rather new approach for determination of the velocity field in a ventilated room is by solving the governing equations, which in the isothermal case is the 3 Navier - Stokes equations, the continuity eq. and a turbulence model for closure, where the k, ϵ - model is the most commonly used (see e.g. *Gosman et. al.* [11]), even though other higher order models seems more promising for recirculating flow (see e.g. *Benocci et. al.* [12]).

The method requires knowledge of the boundary conditions. Because of the very complicated inlet geometry which will require too high a discretization for practical use empirical investigations are still of highest importance. Another important problem of this method is the lack of ability to predict low Reynolds number effects, which has been noticed e.g. by *Nielsen et. al.* [4] or *Murakami et. al.* [8] and are elaborated in this paper. The promising thing about this method is that it is able to predict a very detailed flow pattern in complex geometries and therefore a power full design tool.

2. Experimental set-up.

The test room is shown in fig. 1. The inlet device is of the HESCO - type (KS4W205K370) where the flow can be adjusted to any kind of three dimensional flow structure (see ref. [13]). This feature is typical for modern inlet device design. The diffuser consists of 4 rows with 21 nozzles which independently can be adjusted to different directions. For this purpose all the nozzles have been adjusted to an angle of $\phi = 40^\circ$ (fig. 2).

The purpose of this paper is to give a general idea of the flow field in a room with a mixing type of ventilation, to present measurements which can evaluate the "simplified model" approach (*P.V. Nielsen*, [1]), to evaluate a new kind of simplified approach for description of the flow field by means of an impinging turbulent jet (*S. Belas*, [2]) and to evaluate and detect the isothermal flow dependencies of the Reynolds number (the low Reynolds number effects) which also are shown in *P.V. Nielsen and Aa.T.A. Moller* [3], [4].

The general flow field was established by smoke experiments. To full fill the main goals velocity measurements had to be carried out in the center line of the room, in the lower part of the room (the occupied zone) and at different location of a semicircle around the inlet device. All measurements was performed at different air change rates. The measuring locations are listed in fig 3.

Ball probes (Dantec 54N10) were used for measurements below the ceiling and hot wire (Disa 56N24) for measurements in the occupied zone.

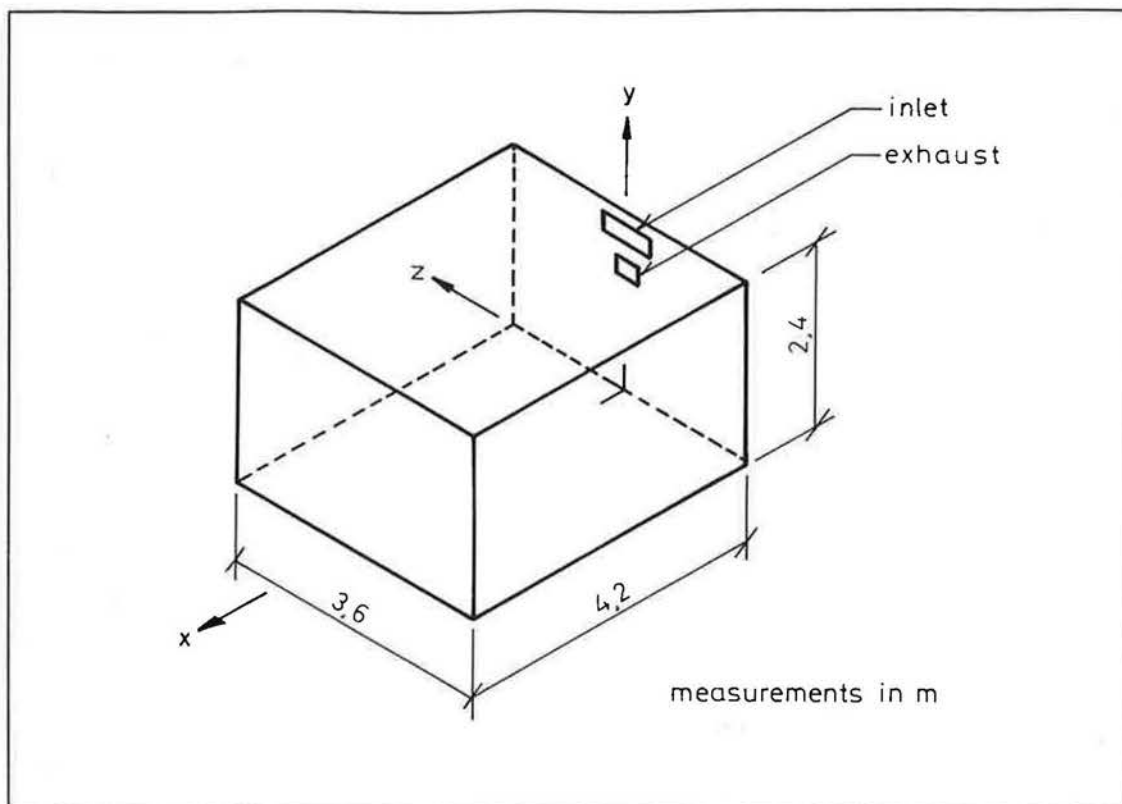

Fig 1 : Sketch of the full scale test room facility

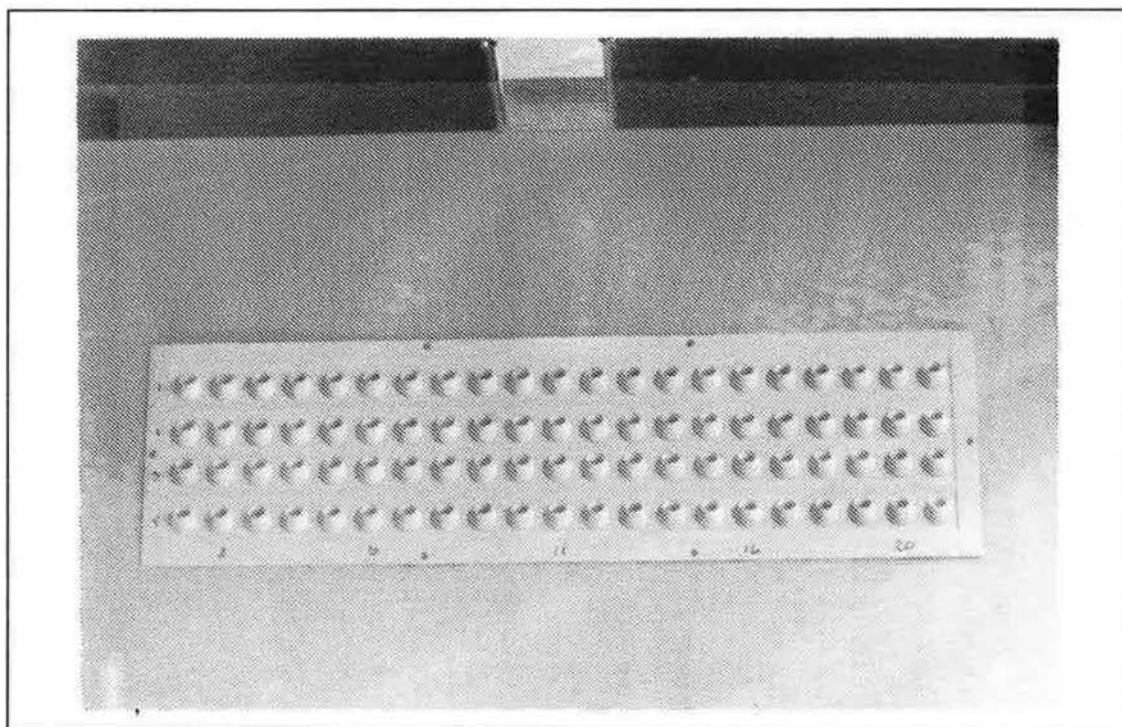

Fig 2 : Close up of the HESCO inlet device. The diffuser consists of 4 rows with 21 independently adjustable nozzles.

x [m]	y ^{*1}	z	num. of measure- ments	air change rates [1/h]	Int. time. [s]	ref.
0.6	2.365 - 1.575	0.0	80	1,2,3,4,6,8	90	1
1.4	2.365 - 1.575	0.0	80	1,2,3,4,6,8	90	2
2.2	2.365 - 1.575	0.0	80	1,2,3,4,6,8	90	3
3.0	2.365 - 1.575	0.0	80	1,2,3,4,6,8	90	4
4.0	2.365 - 1.575	0.0	80	1,2,3,4,6,8	90	5
0.71	2.365 - 1.575	-0.71	80	1,2,3,4,6,8	90	6
1.0	2.365 - 1.575	0.0	80	1,2,3,4,6,8	90	7
0.71	2.365 - 1.575	0.71	80	1,2,3,4,6,8	90	8
1.06	2.365 - 1.575	-1.06	80	1,2,3,4,6,8	90	9
1.5	2.365 - 1.575	0.0	80	1,2,3,4,6,8	90	10
1.06	2.365 - 1.575	1.06	80	1,2,3,4,6,8	90	11
3.6		0.0	23	1,1.5,2,3,4 6,7,8	960	12
3.0		0.0	24	1,1.5,2,3,4 6,7,8	960	13
2.4		0.0	24	1,1.5,2,3,4 6,7,8	960	14
1.8		0.0	23	1,2,3,4,5,6 7,8	960	15
1.2		0.0	27	1,2,3,4,5,6 7,8	960	16

*1 The upper bound of the y coordinate includes the location of the maxium velocity.

Fig. 3 : Data from the measurement sequence. The air change rate correspond to $Re|_a = (\sqrt{a_0} u_0) / \nu \in [7500; 57000]$ or $Re|_d = (du_0) / \nu \in [1000; 7000]$.

3. Analysis and results.

The measurements of the effective inlet area, a_0 , were performed at 10 different locations (10 different nozzles) spread over the diffuser area in the Reynolds number range 625-9700. The results are depicted in fig. 4.

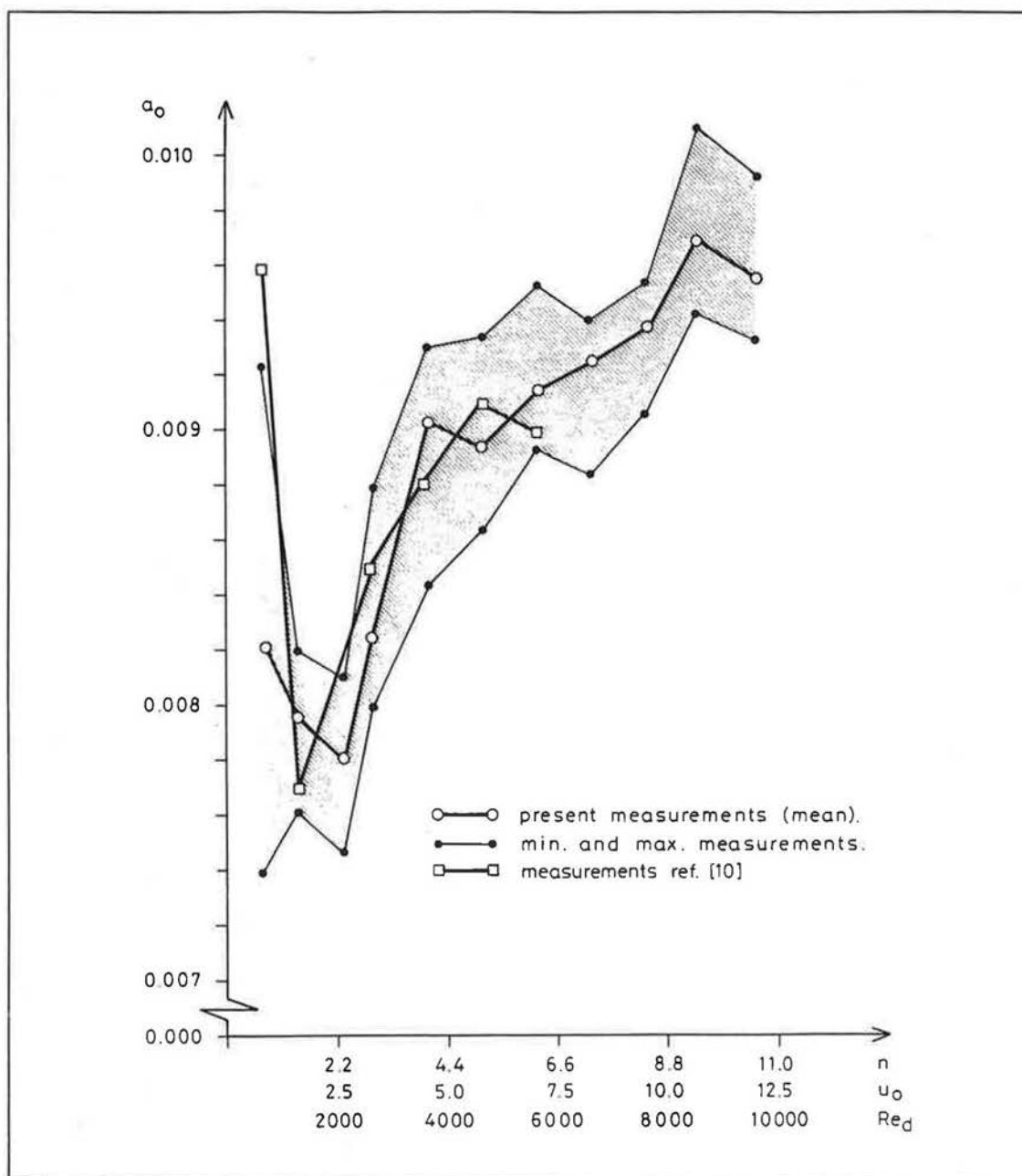

Fig.4 : The effective inlet area a_0 as a function of the inlet velocity.

As it can be seen the a_0 area is not a constant, but an increasing function in the Reynolds number due to the transition from laminar to turbulent flow through the nozzles. The curve has a minimum which is referring to the transition point. This transition is at Re_d equal to 2000 which corresponds to the assumed critical Re for a tube. The large a_0 value for $n = 0.5 h^{-1}$ may be explained by asymmetric flow in the opening or geometrical effects within the diffuser.

For the total flow in the room the essence of fig. 4 is very important. It means that the flow even though it is turbulent has a dependency of the supply velocity which can be interpreted as an initial laminar effect. This means, that a precise calculation of the flow field is a very difficult task (*Murakami et. al.* [8]).

The measured velocity profiles close to the ceiling are shown in fig. 5 for the plane $z = 0.0$ at different x locations (ref. 1, 2, 3, 4, 5 in fig. 3). The profiles have a self similar form for the different supply velocities and the decay is very close to the decay of a universal wall jet. This fact is the reason why the traditional "simplified model" approach has been extensively used for designing inlet devices for mixing jet ventilation systems (see next paragraph).

3.1 Analysis related to the wall jet approach.

The velocity distribution in front of the diffuser has a self similar profile at different air change rates which is typical for a wall jet. Another typical characteristic for the turbulent wall jet is the width δ which is proportional to the distance from a virtual origin (*Rajaratnam* [5]). For both the xy - and the xz - plane the following relation is valid.

$$\delta = D_a (x + x_0) \quad (6)$$

From fig. 6 it is seen that D_a is found to be 0.08 and x_0 is 0.45m.

Rajaratnam and Pani [5], [6] found the value of D to be 0.09 - 0.1 and the virtual origin was located 20 times the height^a of the inlet height behind the inlet in the xy - plane in the case of a bluff wall jet. In the case of a radial impinging jet *Beltaos* [2] found an average value of D_a equal to 0.079. This indicates that the approach with modelling the inlet conditions by means of a radial jet so far seems to be most promising.

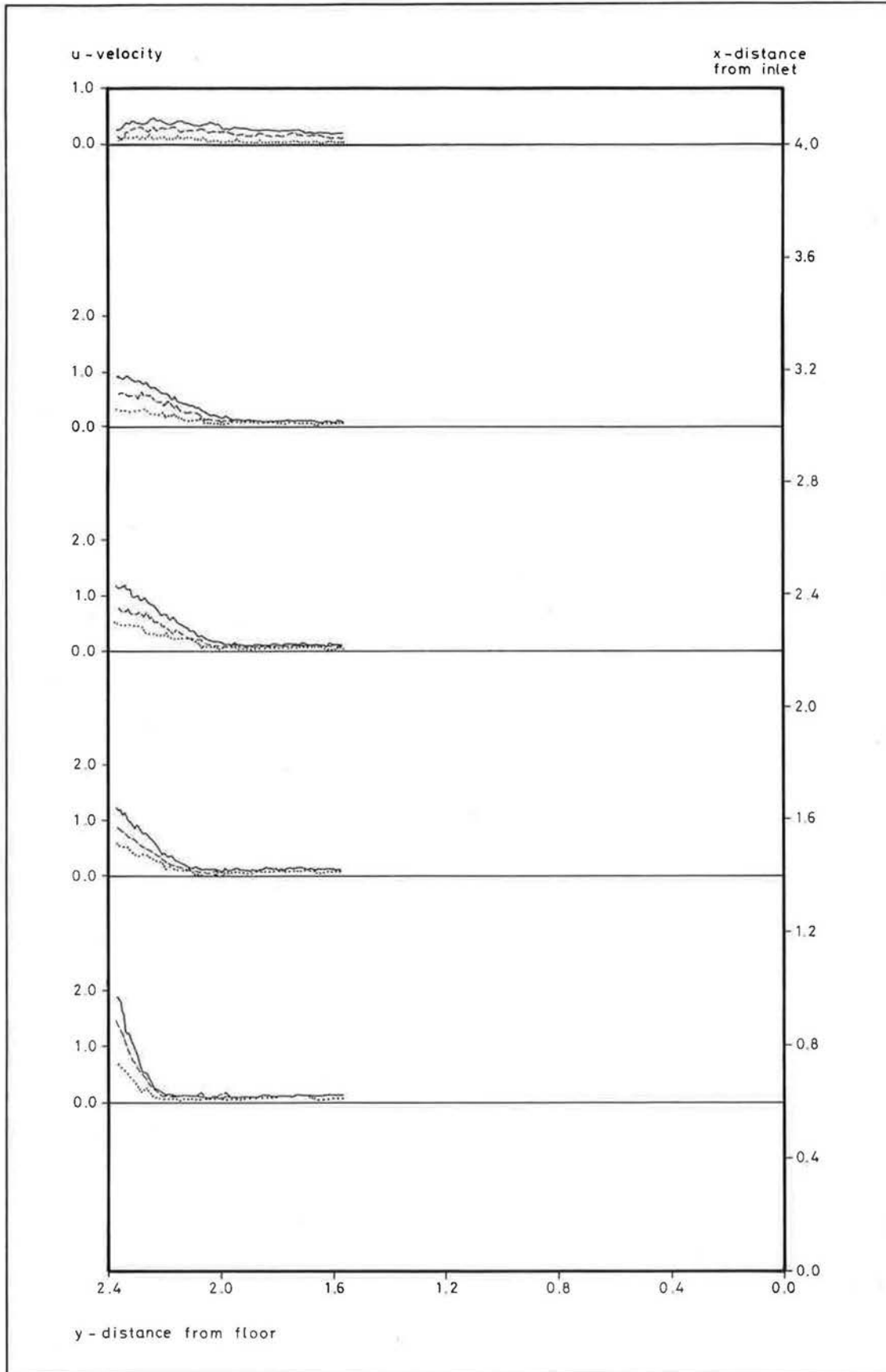

Fig. 5 : Measured velocities in the $z = 0.0$ plane for different downstream locations in the parabolic flow-region. Absolute velocity profiles for $n = 2, 4, 6$ 1/h.

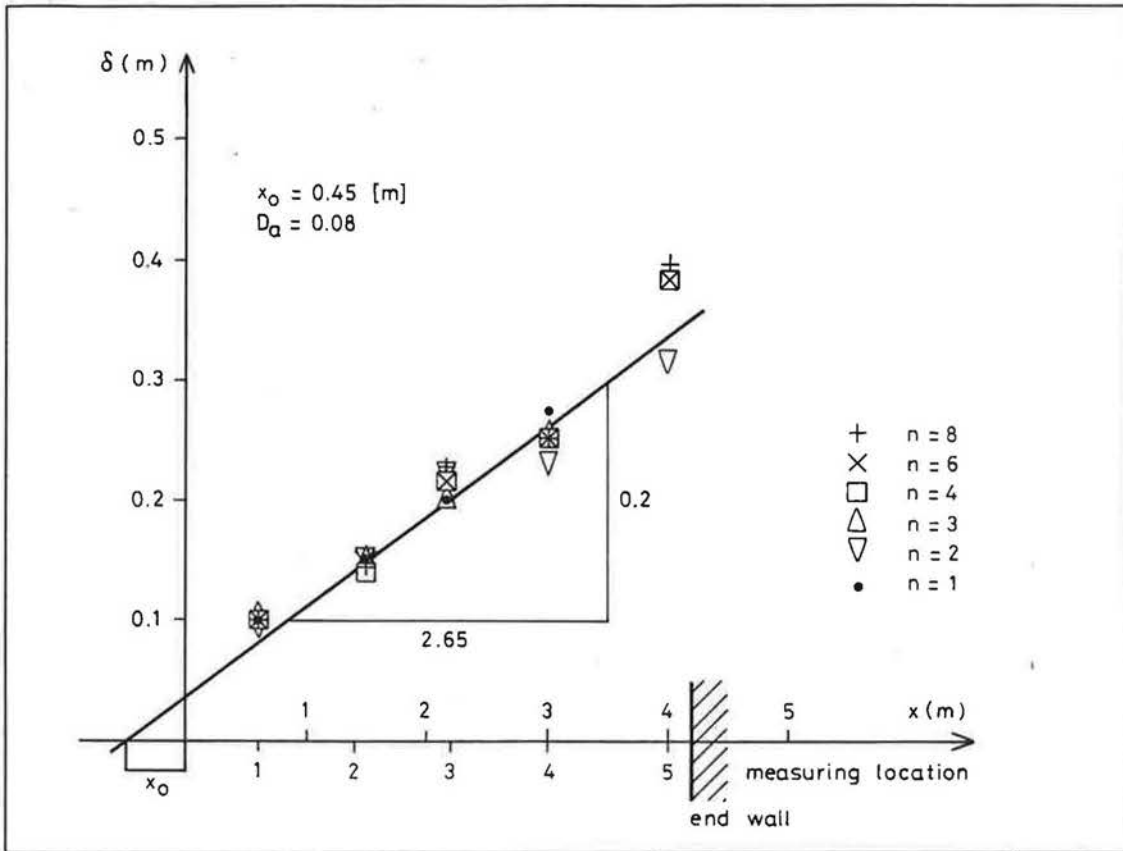

Fig. 6 : The width δ in the xy - plane as a function of x .
 D_a is found to be 0.08 and x_0 is found to be 0.45m.

3.2. Analysis related to the "simplified model".

In the simplified model approaches the determination of the K_a -value and the linearity of the velocity in a point as a function of air change rate is an essential assumption.

If we assume that eq.(1) is valid, which means that we a priori neglect the initial low Reynolds number effect due to the transition of the flow through the nozzles, we can expect that u_x/u_0 as a function of $(x+x_0/\sqrt{a_0})$ will be a straight line in a logarithmic coordinate system with the slope -1. Fig. 7 shows that the slope is only equal to one in the middle of the room. Near the inlet device the slope is near -0.5, which is typical for the decay of the center line velocity in a two-dimensional jet (*Trentacoste and Pforza* [7]). Near the end wall the decay of the velocity is increasing due to the geometrical extension of the room.

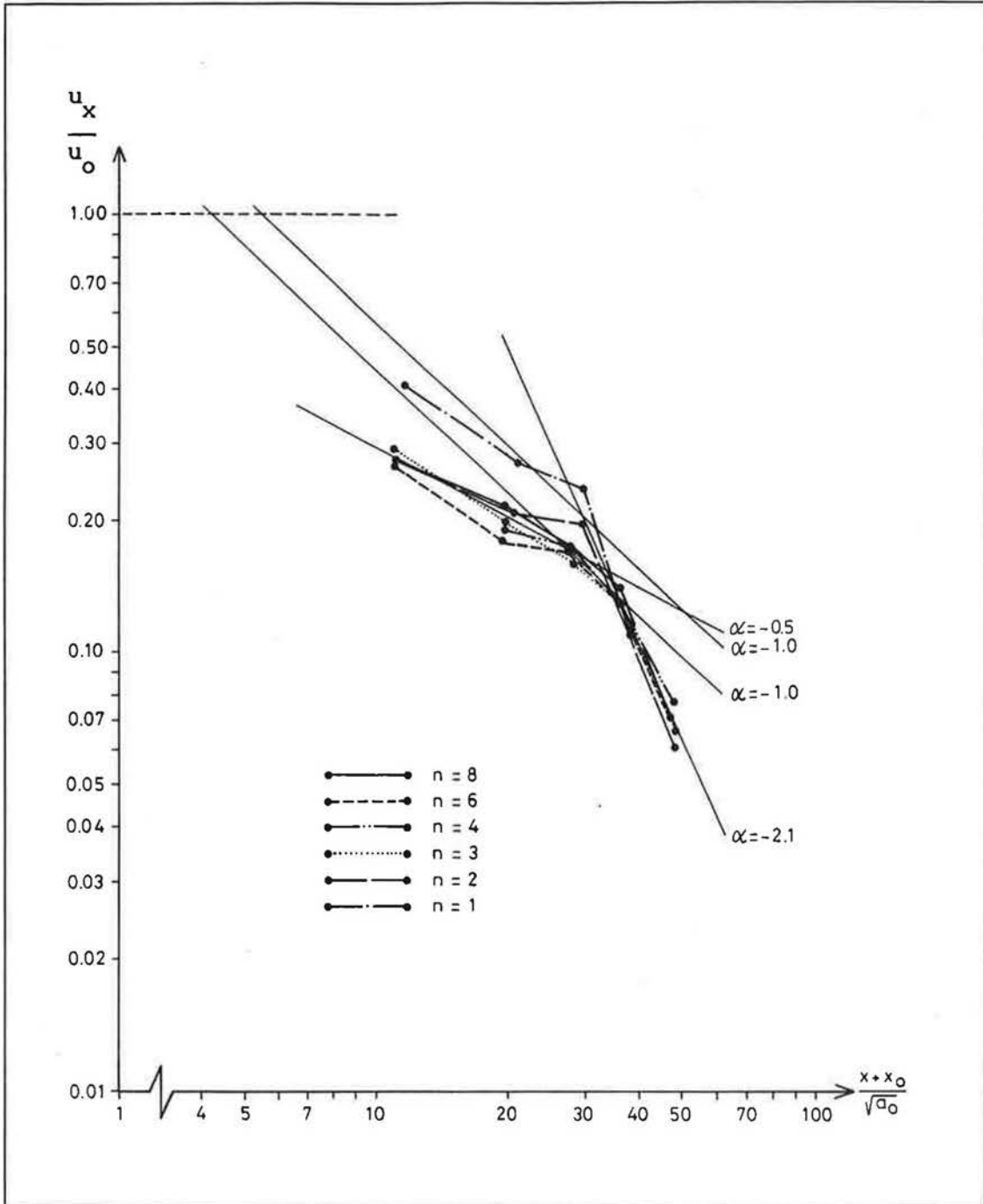

Fig. 7 : Measured decay of the center line velocity for $n = 1, 2, 3, 4, 6, 8$. The k -value is found to be 5.2 for $n = 1$ and 4.2 for $n = 2, 3, 4, 6, 8$.

Fig. 8 shows the maximum velocity at 5 different yz -planes (ref. 1, 2, 3, 4, 5 in fig. 3) as a function of the air change rate. The figure shows the effect from the inlet device very clearly since the maximum velocity is larger than expected for low air change rates with fully developed turbulence. If one follows the development of the maximum velocity for air change rates 1 and 2 h^{-1} one can see that it is decaying faster than expected. This means that there is an additional effect which contributes to the decay of the velocity in the low Reynolds number area.

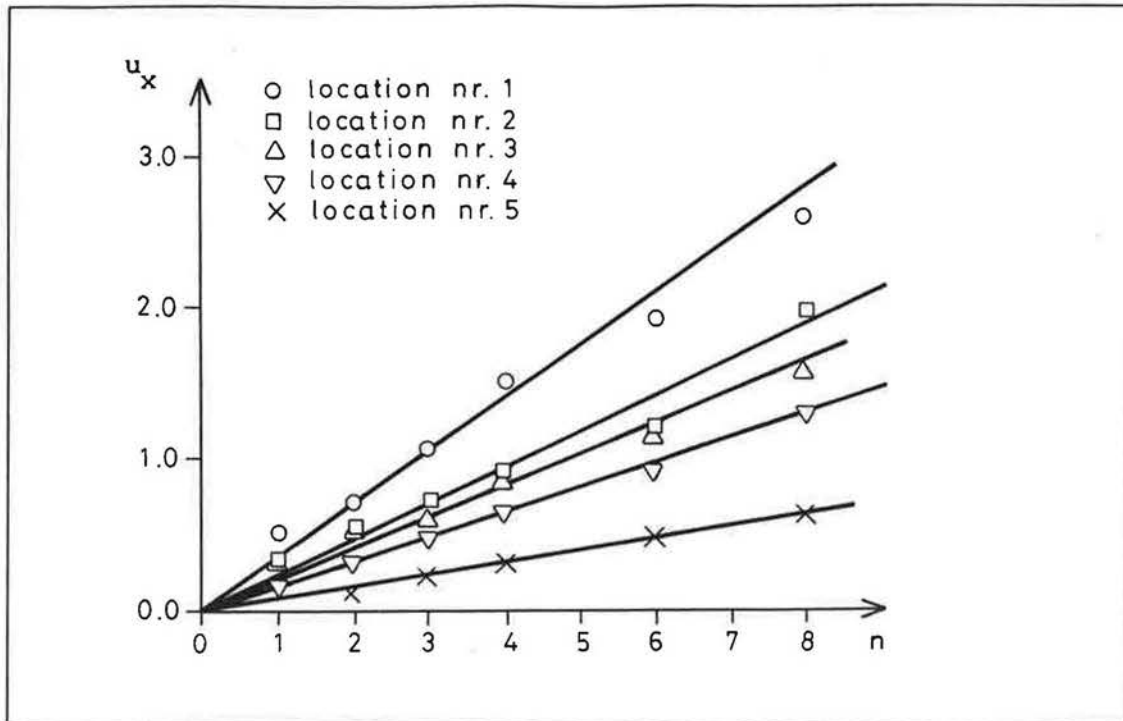

Fig. 8 : The center line maximum velocity for different air change rates at different xy - planes located at ref. 1,2,3,4,5 in fig 3.

3.3 Analysis related to the impinging jet approach.

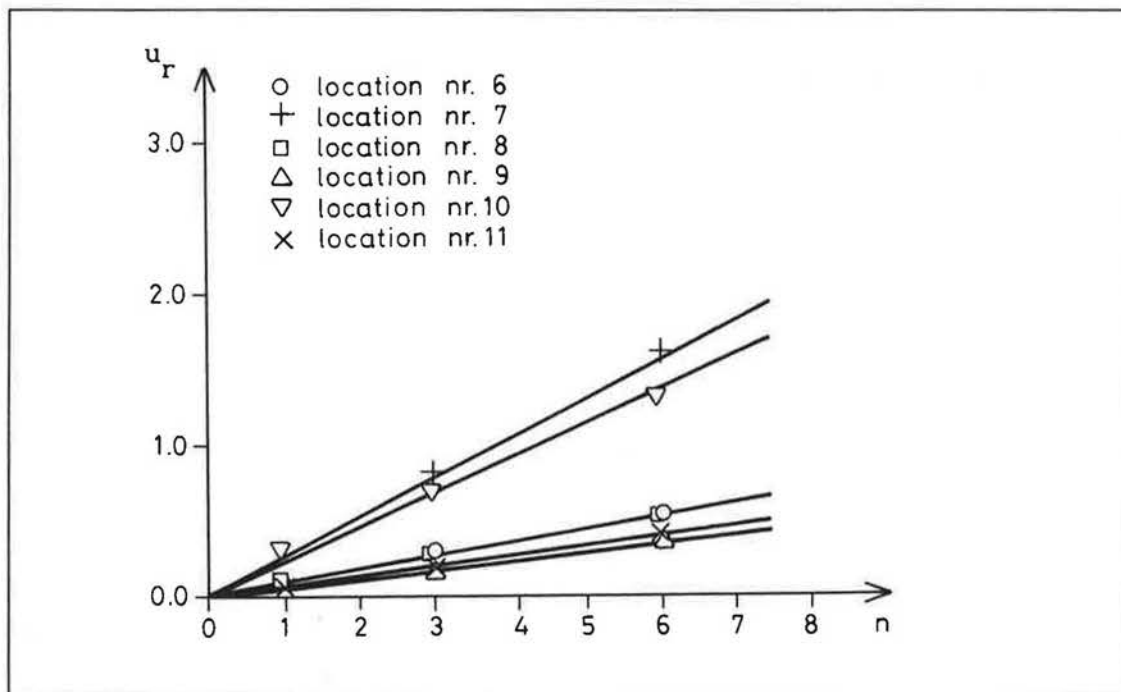

Fig. 9 : The maximum velocities at $\theta = 0^\circ$ and $\pm 45^\circ$ as functions of the air change rate. $\phi = 40^\circ$.

Fig. 9 shows the maximum velocities for different air change rates and different ϑ 's . This figure shows that the decay of the velocity is linear and that the velocity is symmetric around the center line.

Beltaos [2] found by means of the π - theorem that u_o/u_r plotted against r/d for fixed ϕ and ϑ should result in straight lines and the slope should be reciprocal to K_1 in eq. (3) for high Reynolds numbers. Since this paper is testing the approach in eq.(5) u_o/u_r is plotted against $r+x_o/\sqrt{a_o}$. As it can be seen in fig. 10 there is a distinct difference between $\vartheta=\pm 45$ and $\vartheta=0$. It is also seen that the slope of the interpolated lines is difficult to estimate precisely because of the geometrical extension of the room makes it impossible to obtain measurements in the range $r+x_o/\sqrt{a_o} \in [20;50]$ which is the interval where the slope can be measured unambiguous (Beltaos [2]).

Using the approach from the previous paragraph the $k(\phi, \vartheta)$ is measured to 4.2 for $\vartheta = 0$ and 1.1 - 1.5 for $\vartheta = \pm\pi/4$.

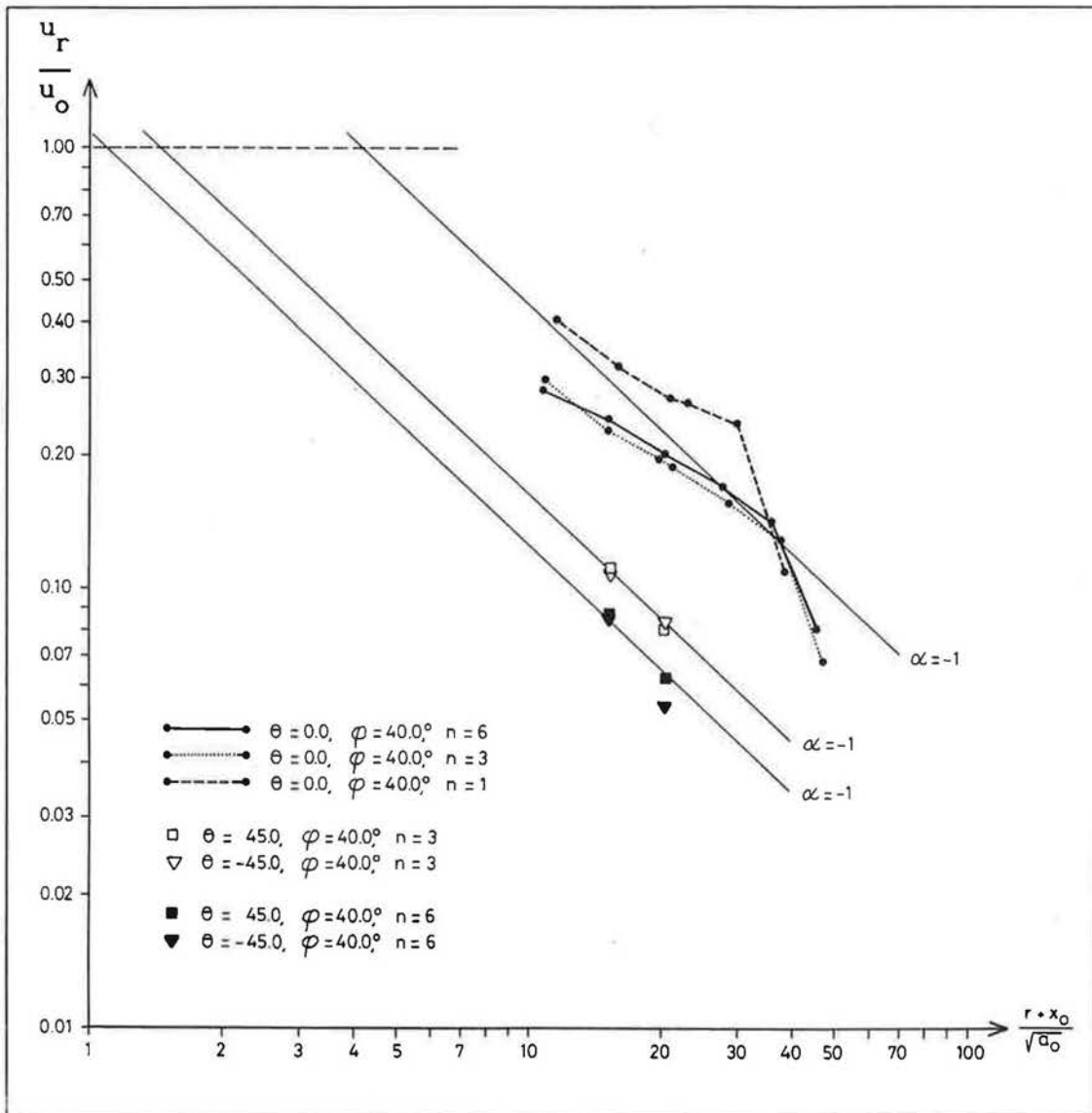

Fig. 10 : The decay of the maximum velocity for different air change rates at different ϑ values. The $K(40,0)$ is found to 4.2 and the $k(40, \pm 45)$ is found to 1.1-1.5.

We are now able to perform a comparison between the $K_1(\phi, \vartheta)$ obtained by *Beltaos* [2] and the present $K(\phi, \vartheta)$. This is done for high air change rates ($3 - 6 \text{ h}^{-1}$) in figure 11. When performing this comparison one must remember that the $K_1(\phi, \vartheta)$ - values obtained by [2] are the case of a single circular jet impinging on a smooth wall where no geometrical restrictions of the flow are present. In the present case is the flow from the inlet device not a well defined circular jet and the flow is confined by the walls. Nevertheless, the outline of the present $K(\phi, \vartheta)$ - values is a pronoun statement of the elements of the 3d-wall jet and the radial impinging jet in the inlet flow.

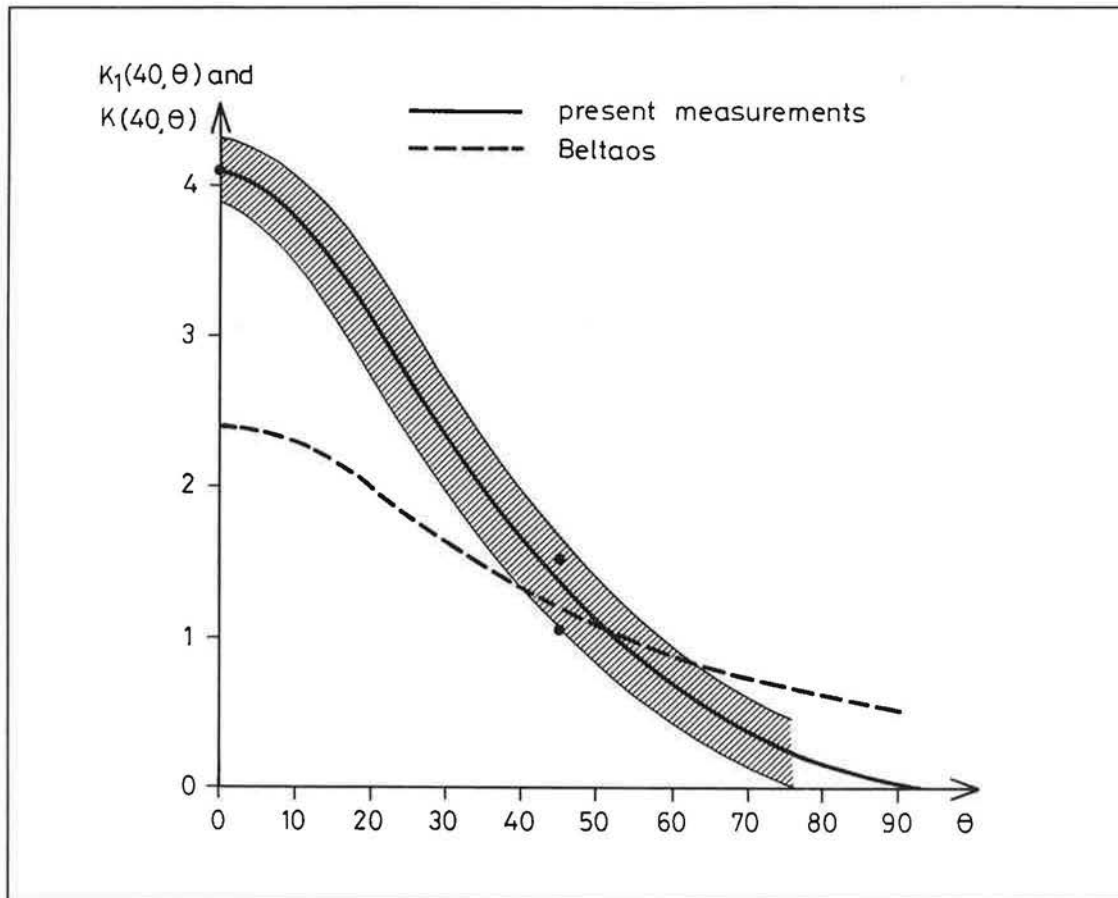

Fig 11 : Comparison of the $K(40, \vartheta)$ values found in a circular impinging jet an in the inlet flow from a HESCO -diffuser.

3.4 Analysis related to measurements in the occupied zone.

If we follow the assumption that the flow pattern in a ventilated room is fully turbulent - independent of the Reynolds number and disregarding the initial low Reynolds number effects - eq. (2) reduces to

$$u_{rm} = c n \quad (7)$$

It is shown in paragraph 3 that this expression isn't valid if the

inlet device is designed so a laminar to turbulent transition is occurring in the used velocity range.

It has also been shown that even if the velocity profiles has the wall jet characteristics of self similarity (fig.5) and linear growth of width (fig. 6) a faster decay of the velocity jet below the ceiling than described by (1) can be expected. This indicates a low Reynolds number effect. The effect becomes more evident if the recirculating flow in the occupied zone is examined.

Figure 12 shows that the self similarity of the velocity profile at a certain point in the recirculating flow depending of the air change rate dissolves.

Fig. 13 shows the velocity as a function of the air change rate . The figure illustrates the validity of (7). It is seen that the equation is valid for high air change rates. The validity range in terms of n is different for different x - values but the validity range seems to be $u > 0.10-0.15$ m/s in terms of velocity. The effects of low turbulence is significantly below this velocity. These effects are reflected in the changes in a and K_a which are treated previously. The low Reynolds number effects which are directly coupled to the room are not included in the two parameters mentioned above, for this room effect a third parameter is needed - the f_1 parameter in equation (2). It is possible to estimate this parameter which has been done in Fig.14 and depicted in fig. 15.

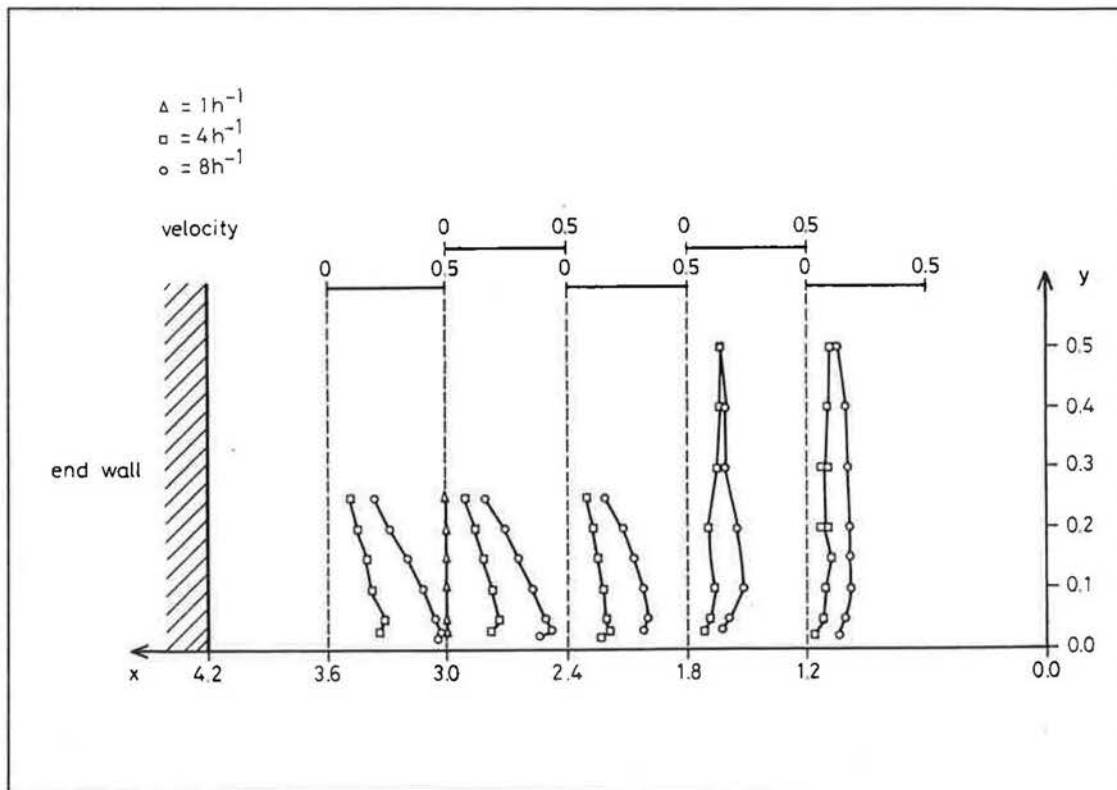

Fig. 12 : Velocity profiles in the occupied zone at different x distances from the inlet.

It is clearly seen that even if the changes in the inlet conditions are

taken into account there is a distinct influence from the low Reynolds number flow in the room - corresponding to the change in f_1 .

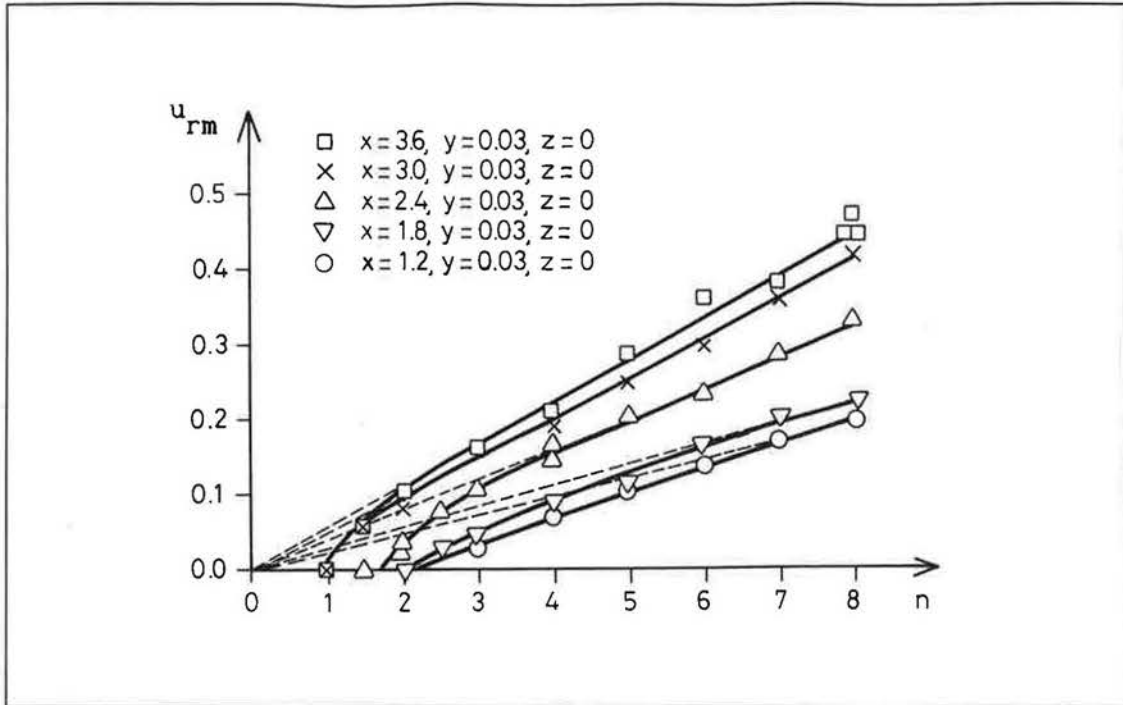

Fig. 13 : The velocity in the occupied zone as a function of the air change rate for different distances from inlet. All measurements is in the mean plane.

n	u_{rm}	u_o	K_a	$\sqrt{a_o}$	$(L + x_o)$	f_1	Δf_1
1	0	1.3	5.2	0.089	4.65	0	+ 0.15
2	0.1	2.4	4.5	0.091	4.65	0.47	\mp 0.09
3	0.16	3.5	4.2	0.093	4.65	0.54	\mp 0.07
4	0.22	4.6	4.2	0.095	4.65	0.56	\mp 0.05
5							
6	0.33	6.7	4.2	0.096	4.65	0.57	\mp 0.03
7							
8	0.44	9.0	4.2	0.096	4.65	0.56	\mp 0.03

Fig. 14 : Estimation of function f_1 . The values of u_{rm} , u_o , K_a , a_o and x_o are taken from fig. 13, 4, 7, 4 and 6. The value Δf_1 is due to measuring inaccuracy of $u \mp 0.02$ m/s.

At low air flow rates even a very small temperature difference may result in a significant buoyancy effect. This effect has been tested and the non linearity in fig. 13 or the variation in f_1 in fig. 14 and 15 does not contain any influence from buoyancy due to the restricted level of the temperature difference which was obtained during the experiments.

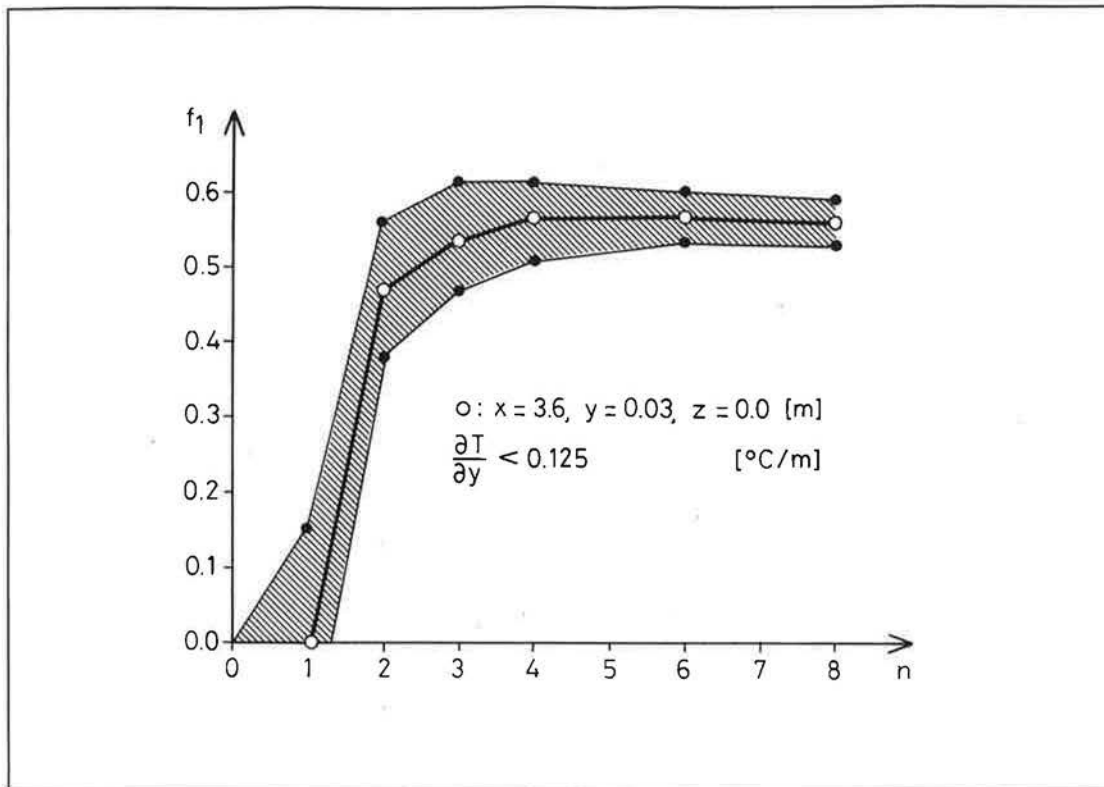

Fig. 15 : Estimation of the function $f_1(n)$. Calculated from the maximum velocity in the occupied zone.

4. Conclusion.

1. The inlet flow from a typical diffuser seems to have elements from both the three dimensional wall jet and an impinging jet.
2. Even though the velocity profiles in front of the diffuser are self similar a faster than expected decay of the velocity is present. This faster decay is caused by a low Reynolds number effect in the center of the room or a upstream influence from the end wall.
3. Low Reynolds effects are present in the velocity field if the air change rate is small. For the present room geometry for $n \in [0;3-4]$ which exactly is the range of practical interest. In the occupied zone the influence of the low Reynolds number effects seems to be significant in the velocity range 0 - 0.15 m/s which also is the range of velocity one usually would tolerate in the occupied zone in e.g. an office.
4. The low Reynolds effects seem to arise from two sources : The change in the inlet flow and change in the flow structure in the room. The effects from the inlet are very important to take into

account in both the simplified models and the numerical simulations because the flow field in the room is driven by the inflow momentum. The effects from the room are difficult to take into account in both models. In the simplified model because there the function $f(n)$ probably is different for different rooms. In the numerical simulation there is no suitable Low Reynolds number model available. But one should realize that the predicted velocities in the occupied zone will probably be too high.

Literature.

- [1] Nielsen P.V : Simplified Models for Room Air Distribution. Internal report, IEA Annex 20, University of Aalborg, 1988. ISSN 0902 - 7513 R 8831.
- [2] Beltaos, S. : Oblique Impingement of Circular Turbulent Jets. Journal of Hydraulic Research 14 (1976) no. 1.
- [3] Nielsen, P.V. and Aa.T.A. Moller : Measurement of the Three dimensional Wall Jet From Different Types of Air Diffusers. World Congress on heating, ventilating and air conditioning, 1985.
- [4] Nielsen, P.V. and Aa.T.A. Moller : Measurements on Buoyant Jet Flows From a Ceiling Mounted Slot Diffuser. III seminar on Appl. of fluid mechanics in environmental protection, Silesian Tech. University, Gliwice, Poland, 1988.
- [5] Rajaratnam, N. : Turbulent Jets, Elsevier, Amsterdam 1976.
- [6] Rajaratnam, N. and Pani, B. S. : Three Dimensional Turbulent Wall Jets, Proc. A.S.C.E. J. Hydraul. Div., 100, 69-83.
- [7] Trentacoste, N. and Sforza, D. M. : Further Experimental Results for Three-dimensional Free Jets., A.I.A.A. Journ. 5, 885-891, 1967.
- [8] Murakami, S., Tanaka, T. and Kato, S. : Numerical Simulation of Air Flow and Gas Diffusion in Room Model - Correspondence between Simulation and Model Experiment. University of Tokyo 1983.
- [9] Nielsen P.V. : Numerical Prediction of Air Distribution in Rooms - Status and Potentials. In : Building Systems : Room Air and Air Contaminant Distribution (Edited by L.L. Christianson) ASHRAE, 1989 ISBN 0-910110-64-6.
- [10] Larsen , J.H, Kjølgaard, E.W, Agersen, L. : Private communication. The University of Aalborg, Denmark. 1988.
- [11] Gosman, A.D., Nielsen P.V., Restivo, A., Whitelaw , J.H. : The Flow Properties of Rooms with Small Ventilation Openings. Transaction of ASME, Vol. 102. 1980.
- [12] Benocci, C. and Skovgaard , M. : Prediction of Turbulent Flow Over a Backward Facing Step. Proc. 6th int. conf. Laminar and Turbulent Flows. Swansea, UK. 1989.
- [13] Nielsen P.V. : Selection of Air Terminal Device, Internal Report, IEA Annex 20. University of Aalborg. 1988. ISSN 0902-7513-R8838.

Research Item Description No. 1.16 last update: April 11, 89

Title: Measurement of case b, (forced convection, isothermal)

No. of Countries: 5
Investigator 1: M. Skovgaard and Peter V. Nielsen Country: DK
Investigator 2: Reijo Kohonen Country: SF
Investigator 3: Paolo Oliaro, Polit. Torino Country: I
Investigator 4: Tony Lemaire, TPD-TNO Country: NL
Investigator 5: Mats Sandberg Country: S

Project phase: Main Planned effort: person-months
Start: 1. March 1989 End: April 1990

Objectives: To obtain sets of data which can be used for comparison with simulated data and other experimental data.

Present data in a agreed form for evaluation in R.I. 1.22

To store data sets in a specified format for inclusion in a database.

Method: Measurements will be done according to task 1.13. Input parameters will be varied to do a parametric study.

Related Annex-20 Research Items:

Input from: 1.13 (specification of test case with free convection and radiator) and item 1.6 (identify measuring values)

Output to: (Simulation of forced convection, isothermal) 1.19
(Evaluation of measured and simulated data) 1.22

Milestones with goals and products:

Date:

1) Preliminary report	May 89
2) Measured data transmitted to 1.22 for evaluation	15. Jan. 90
3) Draft Report on completed measurements for review	April 1990