

BNL-33846  
Informal Report  
Limited Distribution

BROOKHAVEN AIR INFILTRATION MEASUREMENT SYSTEM (BNL/AIMS)  
DESCRIPTION AND APPLICATION

Russell N. Dietz, Robert W. Goodrich, Edgar A. Cote, and  
Robert F. Wieser

AUGUST 1983

Prepared for the  
Office of Building Energy Research and Development  
and the  
Office of Health and Environmental Research  
of the  
United States Department of Energy

ENVIRONMENTAL CHEMISTRY DIVISION  
DEPARTMENT OF APPLIED SCIENCE  
BROOKHAVEN NATIONAL LABORATORY  
ASSOCIATED UNIVERSITIES, INC.

Under Contract No. DE-AC02-76CH00016 with the  
U.S. Department of Energy

## Introduction

An important aspect of any study on indoor air quality or building energy performance is the need to know the rates at which air is mixed or exchanged between zones within the building structure as well as the rates of infiltration of fresh air and exfiltration of stale air for each zone. Combining this information with the locations and rates at which pollutants are both generated and scavenged, would then provide the complete detail necessary for modeling and predicting the air quality throughout a building.

Brookhaven has developed a unique capability to measure part-per-quadrillion concentrations of a family of perfluorocarbon tracers (PFTs). Together with our unique PFT source and passive sampler, measurement of average air exchange and infiltration rate can be determined for periods as short as 12 hours. A more expensive programmable sampler can provide information on a frequency of as little as once per minute for each of its 23 sampling tubes.

The principal of AIMS is based on the applicable steady-state assumption that the average concentration (e.g., in pL/L) of a tracer vapor in a chamber (i.e., a building or room) is equal to the emission rate of the tracer source (e.g., in pL/min) divided by the air leakage or infiltration rate (e.g., in L/min). Knowing the source rate and measuring the average concentration then provides a means to calculate the air leakage rate. Extending this technique to a multichamber concept, in which a different type of PFT source is deployed in each chamber of a building, allows the calculation of not only the infiltration rates in each chamber but also the air exchange rates between chambers as well. Since both the PFT source and the passive sampler, a miniature Capillary Adsorption Tube Sampler (CATS), are about the size of a cigarette, inexpensive, and reusable, the BNL/AIMS is a very cost-effective means (if not the only means) for determining these air exchange rates.

## Use of BNL/AIMS in Homes

Figure 1 shows a capillary adsorption tube sampler (CATS) on the left and a PFT source on the right. The attractiveness of this system is that both the source and the sampler are inexpensive, passive, and easily mailed to the user. A second version of a CATS device (model PS-4) is shown in Figure 2 and is even simpler to manufacture. During deployment of the system in a home, a PFT source is placed in each major room of a house, generally one for each 500 ft<sup>2</sup> of living space. This establishes a uniform tracer concentration within the house. From 2 to 4 passive samplers (CATS) are located throughout the house. Sampling commences by passive Fickian diffusion to the adsorbent in the middle of the glass tube when one cap is removed. At the end of the designated sampling period, the cap is replaced and the sampler is mailed back to the laboratory where it is thermally desorbed on a special multiple CATS rack (see Fig. 3) for determination on a gas chromatograph system. The concentration is calculated knowing the sample duration and the air leakage rate is calculated knowing the number of



Figure 1. Passive sampler (PS-1) and PFT source

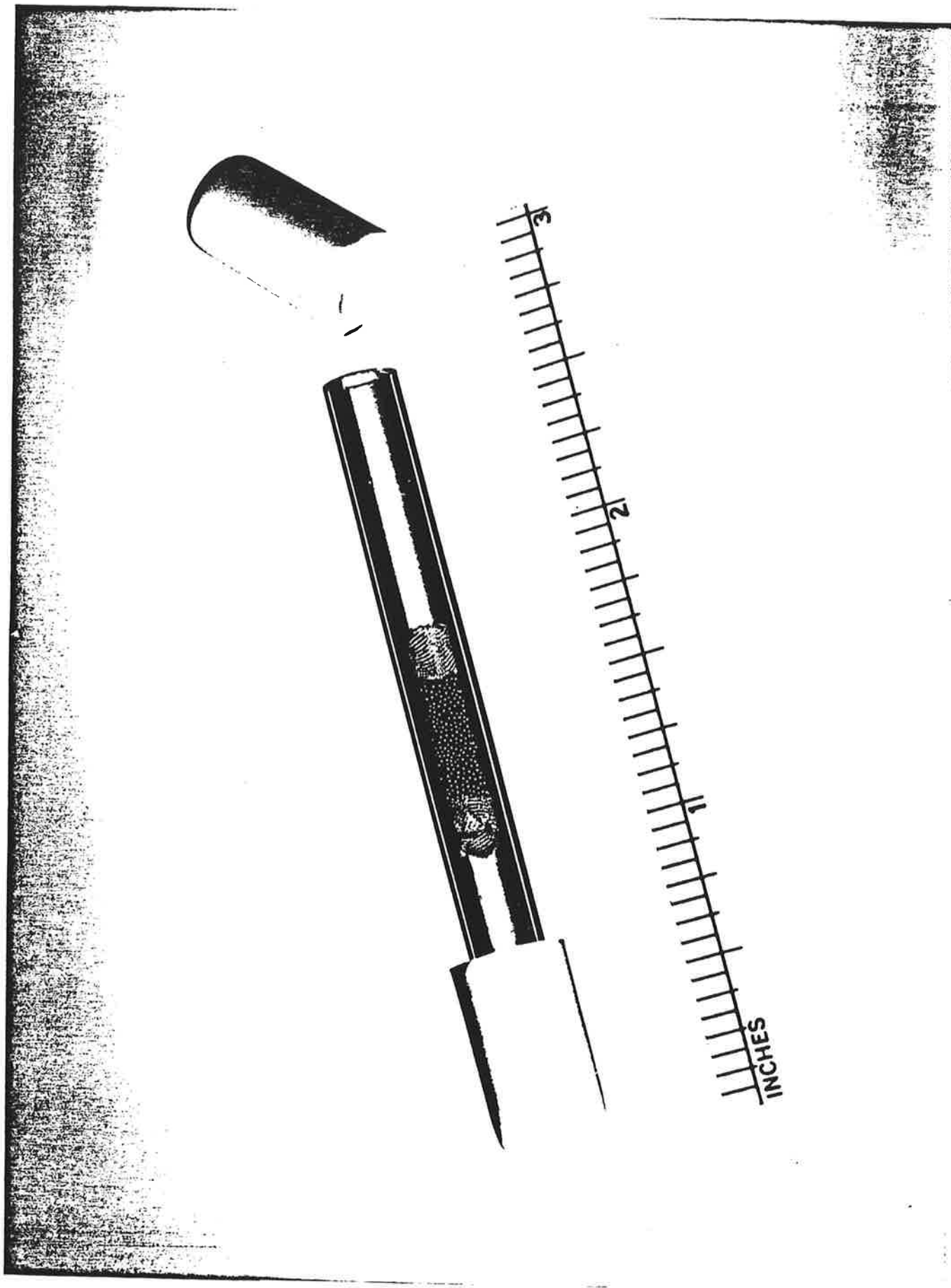
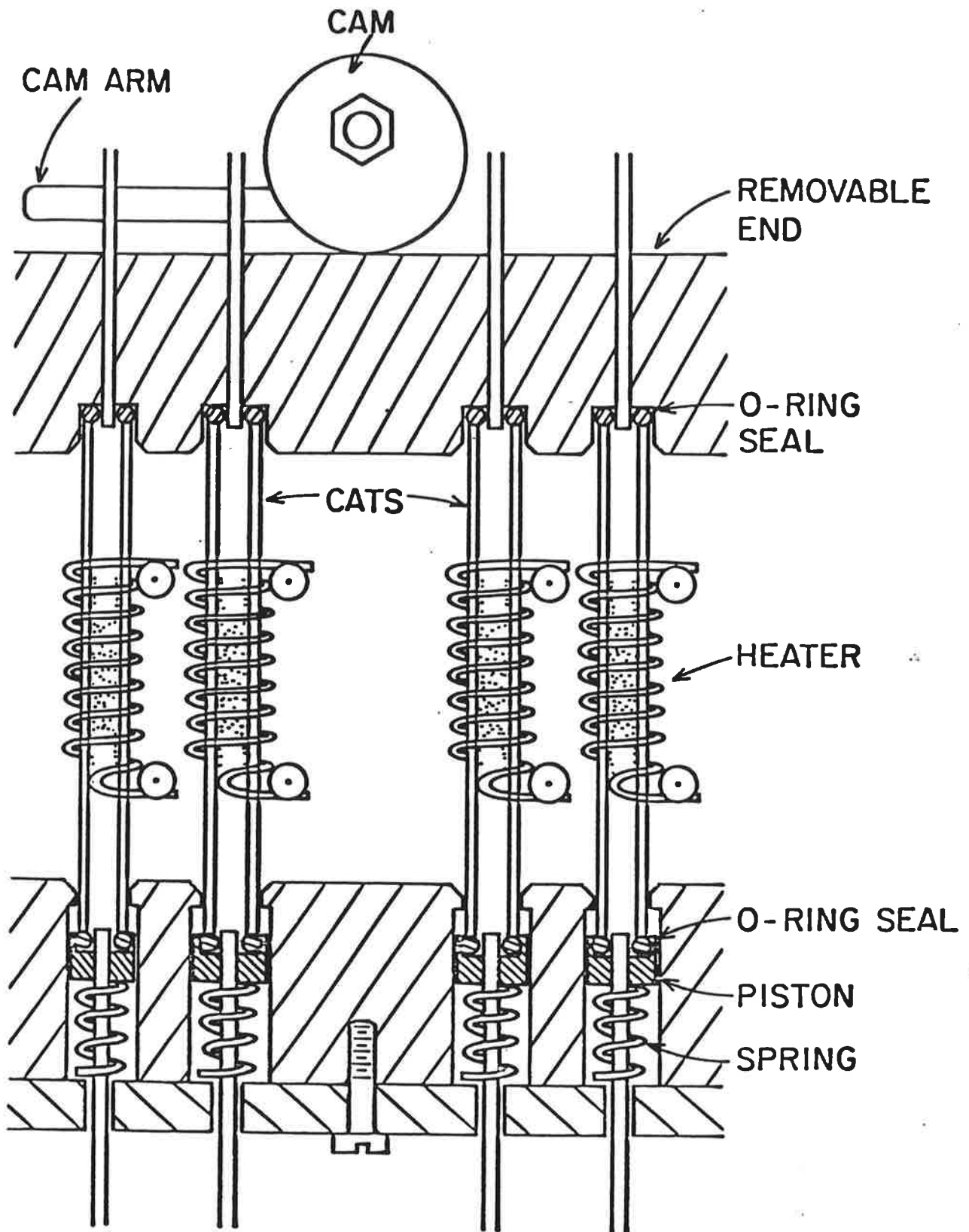

Figure 2. Passive sampler (PS-4).



THERMAL DESORPTION APPARATUS

Figure 3.

PFT sources deployed. Complete details of the technique are provided in three publications.<sup>1,2,3</sup>

The only precaution that must be observed with this technique is that the sources and samplers must be shipped and stored separately to avoid contamination of the samplers with PFTs. Thus, control or unused samplers are routinely considered to ascertain sample integrity.

Validation of AIMS with LBL SF<sub>6</sub> Technique. For the period from June 10 to June 30, 1982, the BNL/AIMS system was deployed in the Lawrence Berkeley Laboratory (LBL) test house in Chicago. This house was equipped with an automated SF<sub>6</sub> tracer decay system which measured the infiltration rate every 90 min. During this period 2 PFT sources were deployed, one in the basement and one on the main floor, as well as two passive samplers each in the basement and main floor.

Table 1 shows the results of the analysis of the four passive samplers. The first and fourth tubes were on the main floor. CATS no. 258 was in the living room where the source was located and no. 250 was at the other end of the house in a bedroom. This accounts for the lower measured concentration in the bedroom which had no source. The second and third CATS tubes were located in the basement, which was a more open space. The two samplers were also about equi-distant from the source, accounting for the more uniform measured concentration.

Using the average concentration from the four samplers, i.e., 10.8 pL/L, an average air exchange rate of  $0.31 \pm 0.04$  ACH (air changes per hour) was determined. LBL determined a mean value of 0.33 ACH from a total of 306 SF<sub>6</sub> decay measurements, in excellent agreement with the BNL/AIMS result.

Example of Single Zone Measurements. In a collaborative study with a Canadian firm, bi-weekly measurements were made in 7 homes in Canada for two test periods. A typical result is shown in Table 2 for house no. 28. Four sources and samplers were deployed in the two-story house with a basement, one of each in the dining and family rooms (1st floor) and the master bedroom and single bedroom (2nd floor), listed, respectively, as CATS numbers 642, 639, 653, and 658. The average infiltration rate was  $0.10 \pm 0.01$  ACH, when the basement volume was included and 0.15 ACH without the basement volume, which is the preferred mode of calculation.

A summary of the results in the 7 homes for the two test periods is shown in Table 3. The trend towards a slightly lower infiltration rate in the second period compared to the first was remarkably consistent, indicative of a warmer period in the second 2 weeks.

Example of a Multi-Zone Measurement. An example of the type of 3-zone results obtained recently in the Brookhaven passive solar heated house is shown in Table 4. Given for each of the 3 zones in the house (1 is the second floor, 2 is the first floor, and 3 is the basement) is the volume, the PFT type and emission rate, the average concentration of each PFT type,

TABLE 1  
CATS ANALYSIS

TUBE POS.	CATS NO.	HRS. SAMP.	AREA, PMCH	INTEGRATOR CTS/1000 PDCH	PFT VOL., PL PMCH	PFT CONC. PL/L PDCH
1	250	476.0		11349.0	32.463	8.744
2	252	476.0		14357.0	41.092	11.063
3	255	476.0		14646.0	41.917	11.290
4	258	476.0		15582.0	44.584	12.008
HOUSE NO.			NO. SOURCES	T(cent)	LAST TUBE POS.	
LB1			2	22	4	

HOUSE NO.	HOUSE VOLUME liters	SOURCE RATE nL/min	AUG. CONCENT PL/L	INFILT. RATE L/min	AUG. AIR CHANGE per hr	REL. STD. DEV. %
LB1	491393	27.2	10.8	2526	0.31	13.1

TABLE 2

BNL-AIMS ANALYSIS

ACCOUNT: PAR	TRACER: PDCH	FILE: 17	HOUSE: PR28
DATES SAMPLED	022883-031583	DATE ANAL.:	3/29/83

HOUSE VOLUME M <sup>3</sup>	SOURCE RATE mL/min	AUG. CONCENT PL/L	INFILT. RATE M <sup>3</sup> /hr.	AUG. AIR CHANGE per hr	REL. STD. DEV. %
799	66.0	50.6	78	0.10	11.8

CATS NO.	TRACER CONC.
642	51.1
639	44.6
653	48.1
658	58.6



Table 3

Summary of Single Zone Infiltration Results

<u>House Code</u>	<u>Avg. Air Changes per Hour (Rel. Std. Dev.)</u>	
	<u>2/15 - 2/28/83</u>	<u>2/28 - 3/15/83</u>
8	0.23 (± 33%)	0.21 (± 41%)
10	0.19 (± 18%)	0.17 (± 17%)
20	0.41 (± 4%)	0.40 (± 8%)
28	0.17 (± 15%)	0.15 (± 12%)
32	0.29 (± 30%)	0.24 (± 28%)
34	0.20 (± 17%)	0.18 (± 22%)
39	0.29 (± 20%)	0.27 (± 25%)

TABLE 4

BHL-AINS

ACCOUNT: BHL 3-83 HOUSE: BHL5 #ZONES: 3 FILE: 48  
 DATES SAMPLED: 032983-040283 DATE ANAL: 5/27/83

ZONE	VOL (M <sup>3</sup> )	SOURCE TYPE	SOURCE RATE (mL/hr)	AUG. TRACER CONC. (pL/L)	PMCH	PDCH	PDCB	EXFILT. RATE (M <sup>3</sup> /hr)	ACPH	INFILT. RATE (M <sup>3</sup> /hr)	ACPH
1	215.0	PMCH	3410	13.6	36.4	13.6	8.0	60	0.28	3	0.02
2	240.0	PDCH	1878	14.1	15.4	14.1	8.0	67	0.28	73	0.31
3	204.0	PDCB	1734	2.5	4.2	2.5	16.6	43	0.21	94	0.46

ZONE-ZONE RATE (M<sup>3</sup>/hr.) CATS# COHC. (pL/L)

1-2	90.4	890	PDCB	8.029	34.189	13.942	PMCH	13.320	PDCB	15.750
2-1	152.3	889	PMCH	7.911	38.592	13.320	PDCB	15.750	PMCH	13.109
1-3	7.5	<del>888</del>	PDCB	7.483	17.026	15.750	PMCH	13.109	PDCB	7.730
3-1	2.7	887	PMCH	7.907	16.383	13.109	PDCB	15.170	PMCH	2.475
2-3	13.1	<del>886</del>	PDCB	14.701	9.400	7.730	PMCH	2.566	PDCB	4.271
3-2	68.4	885	PMCH	8.090	14.418	15.170	PDCB	2.475	PMCH	4.271
		884	PDCB	15.220	4.068	2.475	PMCH	2.566	PDCB	4.271
		883	PMCH	18.024	4.271	2.566	PDCB	4.271	PMCH	4.271

ZONE 1 IS 2ND FLR  
 ZONE 2 IS 1ST FLR  
 ZONE 3 IS BSMT

and the average exfiltration and infiltration rates, expressed both in  $m^3/hr$  and air changes per hour. Note, for example, that most of the fresh air infiltrating into the house is occurring via the basement and very little directly into the second floor. Below are the zone-to-zone air exchange rates and the individual CATS concentration data, which ranged from 2 to 38 parts per trillion. A summary view of the flow rates is shown in Figure 4.

CATS 890, 889, and 888 were on the second floor in the small bedroom, master bedroom, and second small bedroom, respectively. The door to the latter room was closed and thus sampler 888 results were not used in the assessment of mixing and infiltration rates. CATS 887, 886, and 885 were located on the first floor in the family room, kitchen, and living room, respectively. The kitchen location was near the hoodless range vent which penetrated into the basement; thus sampler 886 was biased and not used in the material balance calculations.

Table 5 shows a typical BNL/AIMS Data Sheet which is completed by the user during a measurement period. The average temperature of the sources in each zone of the house or building must be recorded in order to correct for the effect of temperature on the source emission rate which is about 3% for a  $3^{\circ}C$  change in temperature. Because of possible contamination of samplers during improper shipment or storage of the sources and samplers, a control or unused sampler is maintained, if not for every house, at least 2 or 3 for each deployment period in all buildings or homes.

#### Proposed Use of BNL/AIMS in Buildings

During a sampling period in a building, permeation-type PFT sources would be deployed uniformly throughout each zone of the structure, using a different type of tracer for each zone. At this time, three (3) tracer types are available; studies are being conducted to develop one or two additional types. Using PFT sources with high emission rates, i.e., about 30 to 60 nL/min, would allow one source to be deployed for every 5000 to 10000  $ft^2$  of occupied space. If each zone of the building is equipped with an individual HVAC system and can be left running continuously during the testing, then the sources can be simply deployed in the return air plenum. Otherwise the sources should be placed uniformly throughout the zone.

Samplers of the passive type would be deployed uniformly throughout the zone or floor of the building, with a minimum of three or four per zone or floor; one CATS would be left unopened as a control. Each CATS would sample for a designated period. The uniformity of the concentrations on a zone or floor would indicate the degree of mixing in that region and the differences between zones or floors would be used to calculate the average air exchange and infiltration rates.

More detailed measurement of those rates could be provided with the use of the Brookhaven Atmospheric Tracer Sampler (BATS), a 23-tube programmable sampler. Set to collect one tube for an integrated 3-hour period, the 23 tubes would provide 69 hours of more continuous information. Both the cost

of the subsequent data analysis and interpretation as well as the cost of the programmable sampler would increase the measurement cost.

#### Costs for BNL/AIMS Deployment

Currently this technique is not available commercially. On a limited basis, Brookhaven has interacted with federal, state, and private scientific and industrial groups working in the areas of energy performance evaluations and indoor air quality to provide this unique capability, where such application has resulted in advancement of the science of our understanding of such processes in buildings and homes.

The cost of performing infiltration and air exchange measurements with BNL/AIMS has been estimated. For a home, the approximate cost is \$45 per passive sampler per measurement period. Since a minimum of 2 and a maximum of 4 passive samplers are needed, the approximate cost to determine these average flow rates is from \$90 to \$180 per home per measurement period.

For buildings, which would require both greater involvement in planning and interpretation, the cost per sampler is estimated to be about \$75 per CATS per measurement period. With a minimum of 4 samplers per floor or zone and for a 5-story building, a typical cost would be about \$1,500.

Measurements performed in greater detail using the programmable sampler would cost about the same per sample. But since more samples would be collected per measurement period, the total building cost is likely to be higher.

The costs presented here are approximate costs for the use of the sources and samplers, both of which are reusable and remain the property of the supplier, and for analyses, data interpretation and reporting, and for any needed assistance in how to deploy the system. These costs do not include field deployment.

This section is presented solely for the purposes of providing estimates for comparison with other techniques which are available either commercially or on a research basis. It should not be assumed that any potential user can purchase this service from Brookhaven.

#### References

1. Dietz, R.N. and Cote, E.A. Air infiltration measurements in a home using a convenient perfluorocarbon tracer technique. Informal Report BNL 30797R, May 1982; Environ. Int. 8, 419-33 (1982).
2. Dietz, R.N. Brookhaven air infiltration measurement system (BNL/AIMS): Manual for field deployment. Informal report BNL 31544, Feb. 1982.
3. Dietz, R.N., Goodrich, R.W. and Cote, E.A. Performance of a passive perfluorocarbon tracer system for building ventilation and air exchange measurements. BNL 33365, June 1983. For presentation at the Symposium on Measured Air Leakage Performance of Buildings, ASTM, Philadelphia, PA, April 1984.

3 Zone

2nd Floor — 1st Floor — Basement

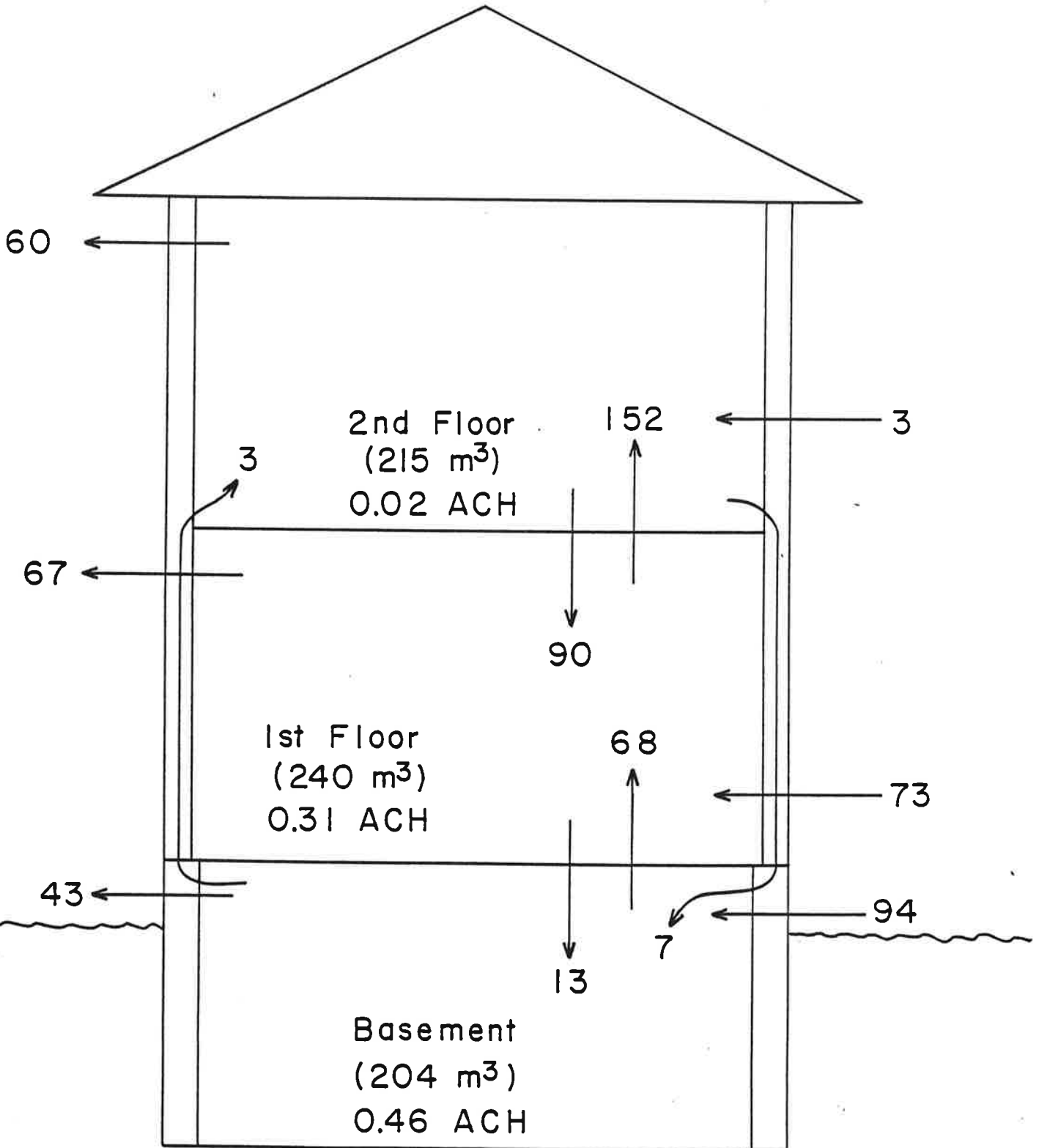

BROOKHAVEN HOUSE  
(All Flow Rates in m<sup>3</sup>/h)

Figure 4

TABLE 5

BNL/AIMS Data Sheet

Account \_\_\_\_\_

House Code \_\_\_\_\_

<u>House Description</u>	<u>Zone No.</u>	1	2	3	4	5
		1 story	Vol. (m <sup>3</sup> ,ft <sup>3</sup> )	_____	_____	_____
2 story	No. Sources	_____	_____	_____	_____	_____
w/basement	*Avg. Temp. OF	_____	_____	_____	_____	_____
split level	**Source Type	_____	_____	_____	_____	_____
w/fireplace	No. Samplers	_____	_____	_____	_____	_____
w/woodstove	Source Rate (BNL)	_____	_____	_____	_____	_____

\*Avg. Temp = (°F x hrs + °F x hrs) ÷ 24

\*\*Source Type = 1st letters or digit of source code TC 340 or 2-42-S60

Source Deployment: Deployed Time \_\_\_\_\_ Date \_\_\_\_\_  
 Removed Time \_\_\_\_\_ Date \_\_\_\_\_

<u>Source No.</u> (Order by zone)	<u>Location</u>			<u>Item Placed On</u>	<u>Comments</u>	<u>Collected</u>
	<u>Zone</u>	<u>Room</u>	<u>Floor</u>			
1. _____	_____	_____	_____	_____	_____	_____
2. _____	_____	_____	_____	_____	_____	_____
3. _____	_____	_____	_____	_____	_____	_____
4. _____	_____	_____	_____	_____	_____	_____
5. _____	_____	_____	_____	_____	_____	_____
6. _____	_____	_____	_____	_____	_____	_____
7. _____	_____	_____	_____	_____	_____	_____
8. _____	_____	_____	_____	_____	_____	_____

Remarks: \_\_\_\_\_

Sampler Deployment: Uncapped Time \_\_\_\_\_ Date \_\_\_\_\_  
 Capped Time \_\_\_\_\_ Date \_\_\_\_\_

<u>Sampler No.</u> (Order by zone)	<u>Location</u>			<u>Item Placed On</u>	<u>Comments</u>	<u>Collected</u>
	<u>Zone</u>	<u>Room</u>	<u>Floor</u>			
1. _____	_____	_____	_____	_____	_____	_____
2. _____	_____	_____	_____	_____	_____	_____
3. _____	_____	_____	_____	_____	_____	_____
4. _____	_____	_____	_____	_____	_____	_____
5. _____	_____	_____	_____	_____	_____	_____
6. _____	_____	_____	_____	_____	_____	_____
7. _____	_____	_____	_____	_____	_____	_____
8. _____	_____	_____	_____	_____	_____	_____
9. _____	C O N T R O L			_____	_____	_____