

# CFD SIMULATION OF AIR VELOCITY DISTRIBUTION IN OCCUPIED LIVESTOCK BUILDINGS

AIVC 12113

K. Svidt<sup>1</sup>, G. Zhang<sup>2</sup>, B. Bjerg<sup>3</sup>

<sup>1</sup>Aalborg University, Aalborg, DENMARK, ks@civil.auc.dk

<sup>2</sup>Research Centre Bygholm, Horsens, DENMARK, gqz6@sh.dk

<sup>3</sup>Royal Veterinary and Agricultural University, Copenhagen, DENMARK, bb@kvl.dk

## ABSTRACT

In modern livestock buildings the design of the ventilation systems is important in order to obtain good air distribution. The use of Computational Fluid Dynamics for predicting the air flow and air quality makes it possible to include the effect of room geometry, equipment and occupants in the design of ventilation systems. However, it is not appropriate to include the detailed geometry of a large group of lying or standing animals affecting the air flow in the building. It is necessary to have relatively simple models of the animals, which are easier to implement in the computer models. In this study laboratory measurements in a ventilated test room with "pig simulators" are compared with CFD-simulations.

## KEY WORDS

Airflow pattern, Air velocity, CFD, Mixing ventilation, Livestock buildings.

## INTRODUCTION

In recent years the use of Computational Fluid Dynamics (CFD) for prediction of airflow in office buildings and industrial buildings has increased significantly due to the extension of powerful desktop workstations and easy to use CFD-codes. The CFD tool is also an interesting possibility to predict airflow and air quality in modern livestock buildings, since there is an increasing attention on working environment and animal welfare. A number of authors have investigated the use of CFD for the prediction

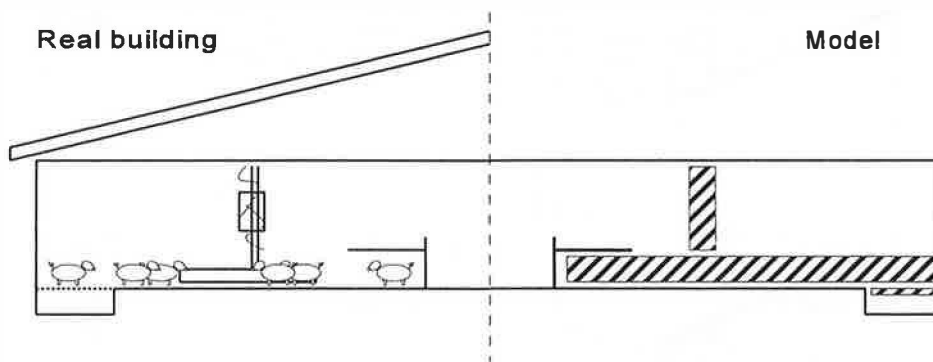

Figure 1 Groups of objects which are too complex to model in every detail can be modelled as volumes with certain characteristics.

of air flow in livestock buildings, e.g. Harral et al (1997), Hoff et al (1992, 1995) and Svidt (1994).

For practical purposes it is not possible to model every detail of the building including all types of equipment and animals. To model the overall airflow pattern, a simpler model will often be adequate.

If the building in case has only a few internal walls or relatively large solid obstacles, it is obvious to model these objects in full detail. On the other hand, a less detailed model will easier to define in case of a large number of objects with a small extent compared to the entire flow domain. This will especially be the case for a group of animals which consists of a number of irregular objects placed in various positions or even moving around within a certain area or volume. Figure 1 shows an example of a building with animals, feeding equipment, pen partitions and a slatted floor as the major geometric objects affecting the air distribution. The right hand side of the figure illustrates that the model of simple geometries (pen partitions) is close to the real geometry, while the groups of more complex objects (animals, feeding equipment and slatted floor) are modelled as volumes with certain

characteristics. In the present study laboratory measurements in a ventilated test room with "pig simulators" are compared with CFD-simulations.

## METHODS

Experiments are carried out in a full scale test room as shown in figure 2. The room dimensions are 3.00 x 8.50 x 5.00 metres. The inlet slot covers the full width of the room and its height is 19 mm. For the CFD boundary conditions, the effective inlet height  $h_{eff}$  is defined as:

$$h_{eff} = \frac{q}{W u_0} \quad (1)$$

where  $q$  : airflow rate [ $m^3/s$ ]  
 $u_0$  : inlet air velocity [ $m/s$ ]  
 $W$  : with of the inlet [ $m$ ]

The effective inlet height is 15 mm based on the measured inlet air velocity, 4.9 m/s and the measured air flow rate, 0.3675  $m^3/s$ . To obtain a two-dimensional flow in the room, four guiding plates are mounted below the

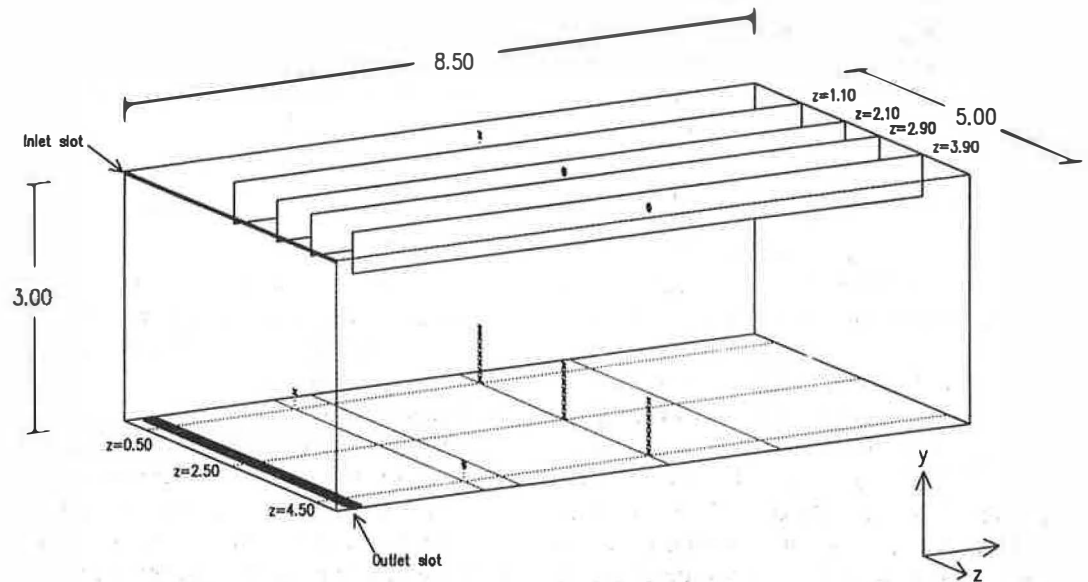

Figure 2 The Full scale test room with inlet slot, outlet slot and guiding plates.

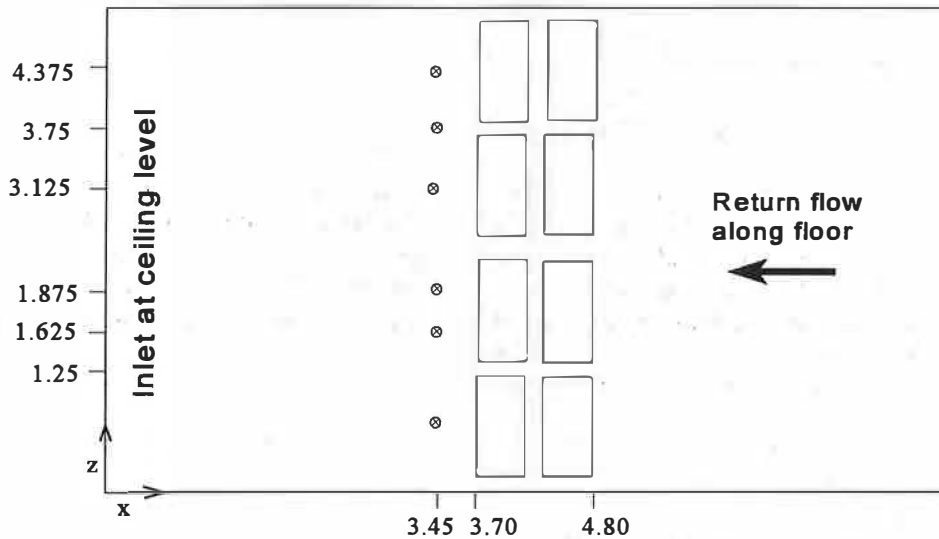

Figure 3 Plan view of the test room. Eight pig simulators are placed in the middle of the room. The position of the measurement columns is indicated downstream from the simulators.

ceiling as shown in figure 2. Air velocity and temperature was measured with a multi point measuring system (Zhang et. al. 1996). Seven sensors were mounted on each of three movable columns.

Eight pig simulators were placed on the floor as shown on the floor plan in figure 3. The cylinders are shaped as a half cylinder with the length 1.05 m and the diameter 0.50 m. Columns for velocity measurements are placed at  $x = 3.45$  m which is 0.25 m downstream from the simulators. In the  $z$ -direction measurement positions are chosen to capture the velocity profiles behind the simulators as well as behind the gap between simulators.

The CFD simulations are carried out with commercial codes by use of the standard  $k, \epsilon$ -model. The calculations are isothermal. A detailed three-dimensional model with approx. 200,000 cells as well as a simpler two-dimensional model with approx. 1,500 cells are investigated. In the two-dimensional model the pig simulators are described as a volume resistance causing a pressure drop as

used by Nielsen et al (1996, 1998):

$$\frac{\partial p}{\partial x} = \frac{f}{2} \rho u^2 \quad (2)$$

where  $\partial p/\partial x$ : Pressure drop [Pa/m]  
 $f$  : loss coefficient  
 $\rho$  : air density [kg/m<sup>3</sup>]  
 $u$  : local air velocity [m/s]

## RESULTS

The result of a three-dimensional CFD simulation is shown in figure 4 and 5. Figure 4 shows a section at  $x = 1.625$  (see figure 3) and figure 5 shows a top view of the calculated flow 5 cm above the floor.

Figure 6 shows a comparison of the calculated and measured air velocities. The left hand side shows that the simulation predicts the position of the maximum velocity to be about 0.5 m above the floor which does not seem to be the case for the measurements. On the right hand side the air velocities

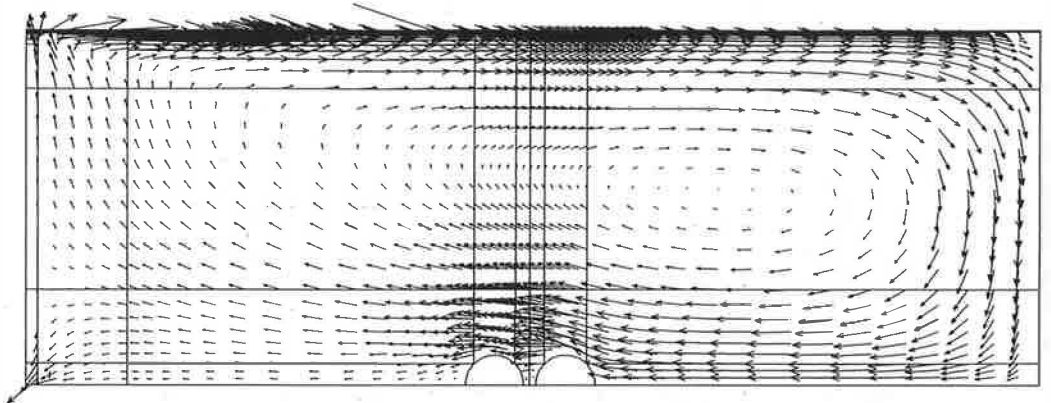

Figure 4 Section view of the calculated air flow with the three-dimensional model. This figure shows the flow field at  $z = 1.625$  m (see figure 3).

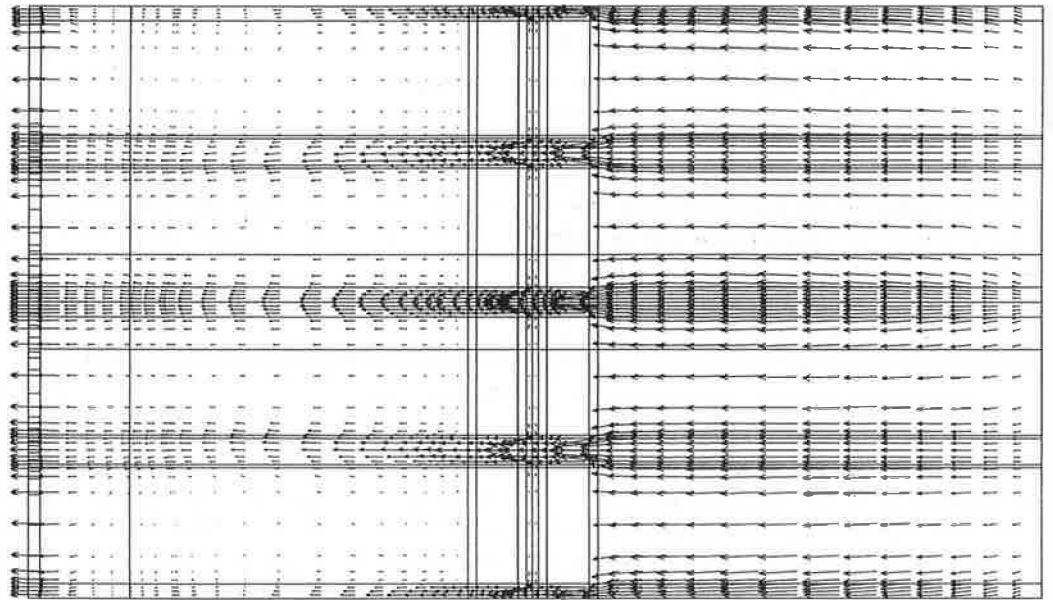

Figure 5 The calculated air flow 0.05 m above the floor.

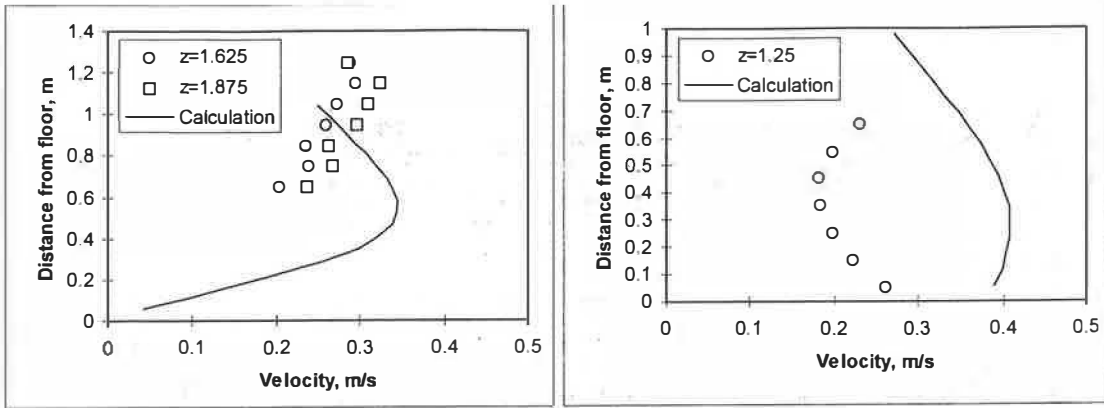

Figure 6 A comparison of the measured and calculated air velocities in the three-dimensional model. Behind a simulator (left) and behind the gap between simulators (right).

behind the gap between two simulators. Here the calculated velocity is significantly larger than the measured velocity.

In the two-dimensional calculations the cylindrical pig simulators are represented as a rectangular volume defined by a free area ratio and a pressure drop coefficient  $f$ . By the choice of coefficients the effect of the volume can be varied from no effect and up to the effect of a solid obstacle. Table 1 shows the combinations of model parameters studied, and the velocity profiles resulting from the different models are shown in figure 7. The free area ratio 0.16 has been defined as the total width of the gaps between the obstacles divided by the room width (see figure 3). The chosen range of loss coefficients  $f$  is based on experiences from Nielsen et al (1996,1998).

It is found that the models with the most solid representation of the volume have the best agreement with the present data. This is shown in figure 8 where the result of model 8 is compared with the air velocities measured downstream from the simulators at various  $z$ -positions.

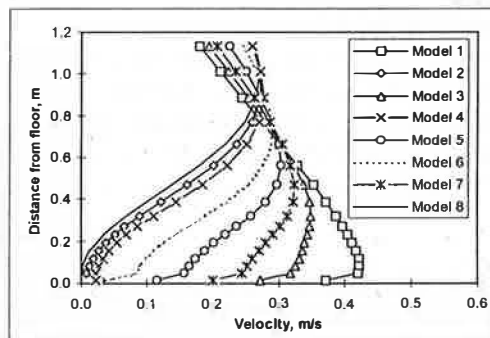

Figure 7 Velocity profiles resulting from various volume resistance models.

Table 1 Parameters of the models studied.

Model	Free area ratio	$f$
1	0.16	0.00
2	0,16	0.50
3	1.00	0.50
4	0.16	0.30
5	0.16	0.05
6	0.16	0.10
7	1.00	1.00
8	0.16	1.00

## DISCUSSION

The internal geometry of a modern livestock building will normally be too complex to describe in a CFD-model. The equipment, floor construction and animals constitute elements of so many details that it is necessary to have a model that does not require the full description of all geometric details. This study has shown that it is possible to have a fair agreement between a simple model based on a volume resistance and the laboratory measurements for the specified case. However, no general recommendations for the choice of coefficients can be given on the basis of this single case. There is a need for further research to specify suitable coefficients for different types of equipment, construction details and animals.

## ACKNOWLEDGEMENT

This research work has been supported financially by the Danish Agricultural and Veterinary Research Council.

## REFERENCES

Harral, B.B., Boon, C.R. (1997) Comparison of Predicted and Measured Air Flow Patterns in a Mechanically Ventilated Livestock Building without Animals. *Journal of Agricultural Engineering Research*, 66:221-228.

Hoff, S.J., Janni, K.A., Jacobson, L.D. (1992) Three-Dimensional Bouyant Turbulent Flows in a Scaled Model Slot Ventilated Livestock Confinement Facility. *Transactions of the ASAE*, 35(2) 671-686.

Hoff, S.J., Li, L., Tsao, L. (1995) Simulated and measured Effect of Rectangular Obstructions on Carbon Dioxide Gas Dispersion in a Scaled Swine Building. *Transactions of the ASAE*, 38(5) 1519-1532.

Nielsen, J.R., Nielsen, P.V., Svidt, K. (1996) Obstacles in the Occupied Zone of a Room with Mixing Ventilation. *Proceedings of RoomVent'96, Fifth International Conference*

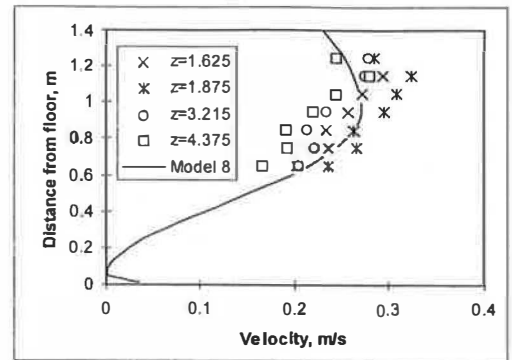

Figure 8 Velocity profile resulting from model 8 compared with measured air velocities at various positions behind the obstacles.

*on Air Distribution in Rooms*, Yokohama, Japan, pp. 137-144.

Nielsen, J.R., Nielsen, P.V., Svidt, K. (1998) The influence of Furniture on Air Velocity in a Room - an Isothermal Case. *Proceedings of RoomVent'98, Sixth International Conference on Air Distribution in Rooms*, Stockholm, Sweden.

Zhang, G, Strøm, J.S., Morsing, M. (1996) Computerized multi-point temperature and velocity measurement system. *Proceedings of RoomVent'96, Fifth International Conference on Air Distribution in Rooms*, Yokohama, Japan.

Svidt, K. (1994) Investigation of Inlet Boundary Conditions for Numerical Prediction of Air Flow in Livestock Buildings. *Proceedings of RoomVent'94, Fourth International Conference on Air Distribution in Rooms*, Kraków, Poland.