

Heat recovery In Natural Ventilation Design of Office Buildings

Trygve Hestad, Eimund Skåret, Jørn T. Brunsell
Norwegian Building Research Institute
P.O. Box 123 Blindern
0314 Oslo
NORWAY
Firmapost@byggforsk.no

Research partly funded by
THE EUROPEAN COMMISSION
in the framework of the
Non Nuclear Energy Programme

ABSTRACT

The application of controlled air flow inlets

In the EU Joule project NatVent one of the work packages was dealing with controlled air flow inlets. During the last conference in Greece an overview was presented on availability, performances and application of controlled air flow inlets. At the presented poster an interactive IAQ computer tool was demonstrated. This tool has been improved and is now available.

Some participating countries in the NatVent project have carried out special tests with the NatVent IAQ tool. The NatVent Participants were asked to design a natural ventilation system according to their national requirements. A second run was asked for a ventilation system which could reach the 1000 ppm CO₂ requirement. The tests of the various countries will be shown. The results of this exercise are very interesting. It shows the positive effect of controlled inlets on IAQ in case of natural ventilation in offices.

Please Note: The full paper will be published in the Supplement to the Proceedings.

1. INTRODUCTION

Heat recovery in ventilation systems for office buildings in cold climates is necessary for two reasons:

1. To obtain acceptable indoor thermal comfort by preheating of fresh air,
2. To reduce ventilation energy loss

This paper describes a pilot system built in the laboratory of the Norwegian Building Research Institute, NBI, based upon the concept of an advanced fan assisted natural ventilation system with heat recovery. The concept was developed by NBI. The objective of making the pilot system was to find out how a real system based upon this concept works and to supply the NatVent project with measuring data both from a winter period and a summer period. The concept is new and is not yet tested in a real office type building.

This paper gives a brief description of the components and the system. The paper also summarises the measurements of the resistance in the system, the driving forces, the temperatures and the airflow.

2. DESCRIPTION OF THE PILOT SYSTEM

2.1. General description

The system is designed to make use of natural driving forces (thermal buoyancy and wind). All components in the system are designed to give a low pressure drop. The system is equipped with an energy efficient assisting fan, electrostatic air filters and a "run-around" heat exchanger.

The build up of the system is shown in fig.2.1 (drawing and photo). The pilot system represents a full scale part of a ventilation system, for instance for one wing of an office building with 3 - 4 storeys, with a ventilation capacity of 400 l/s, i.e. for about 40 persons.

The system consists of three major parts:

1. Roof unit with heat exchanger, coarse filter, assisting fan, a wind-boosted air exhaust unit and a wind-boosted air intake unit. See fig.2.2.
2. Floor unit with electrostatic filter, heat exchanger, space for optional fan (no.2). See fig.2.3.
3. Duct system. Exhaust air ducting with exhaust terminals in three levels. Supply air ducting at three levels with supply terminals (simulated with dampers). As a part of the supply system an insulated vertical main duct connects the air intake of the roof unit with the floor unit.

The system design is described in detail in /1/ and /2/.

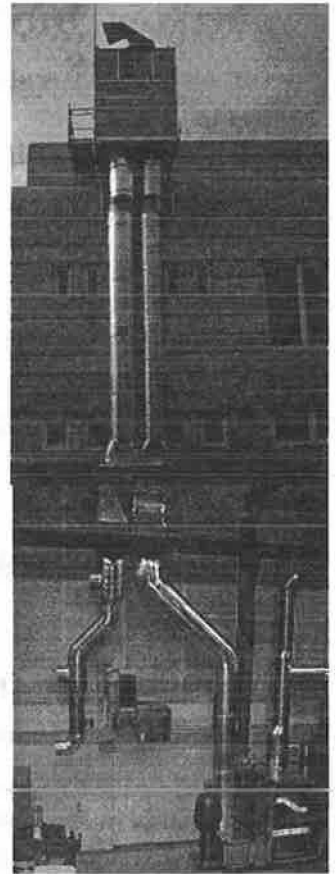
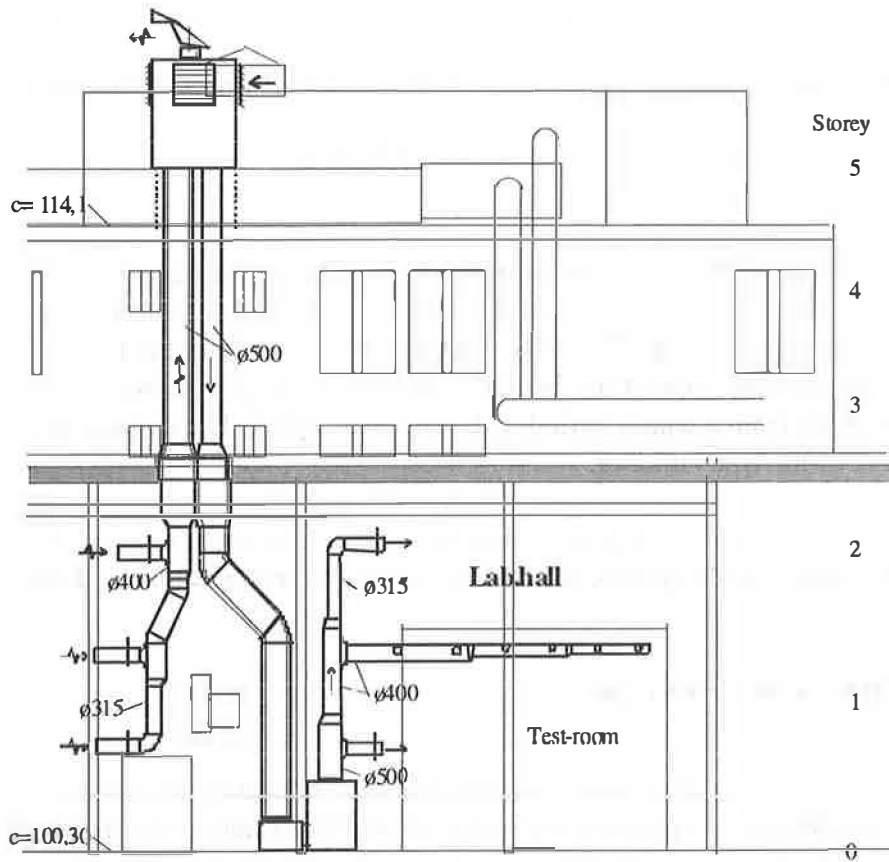

Fig. 2.1. Lab test set up overview

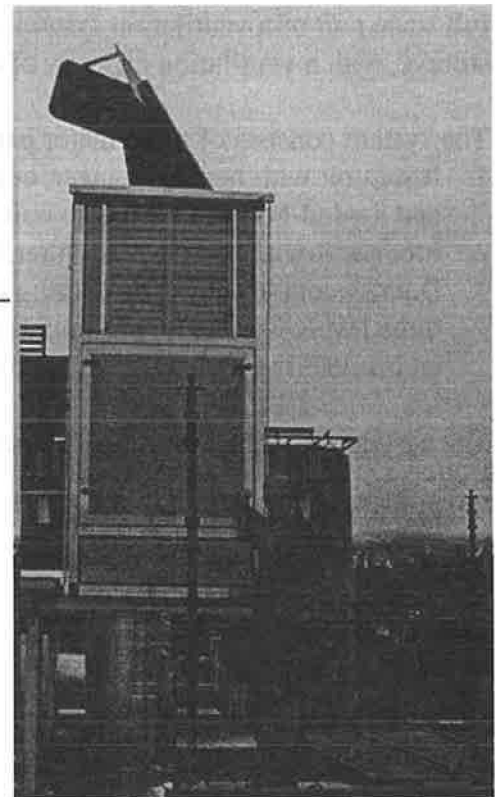
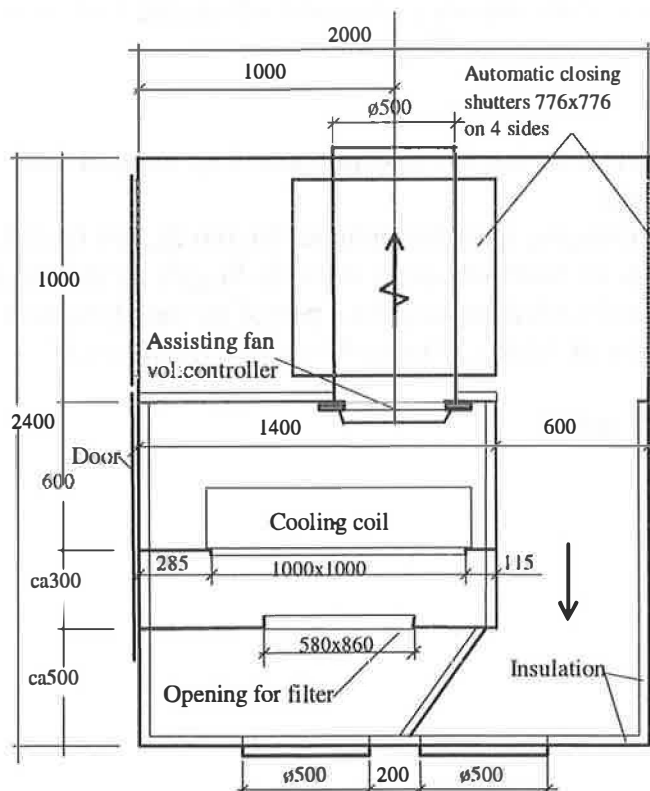

Fig. 2.2. Roof unit

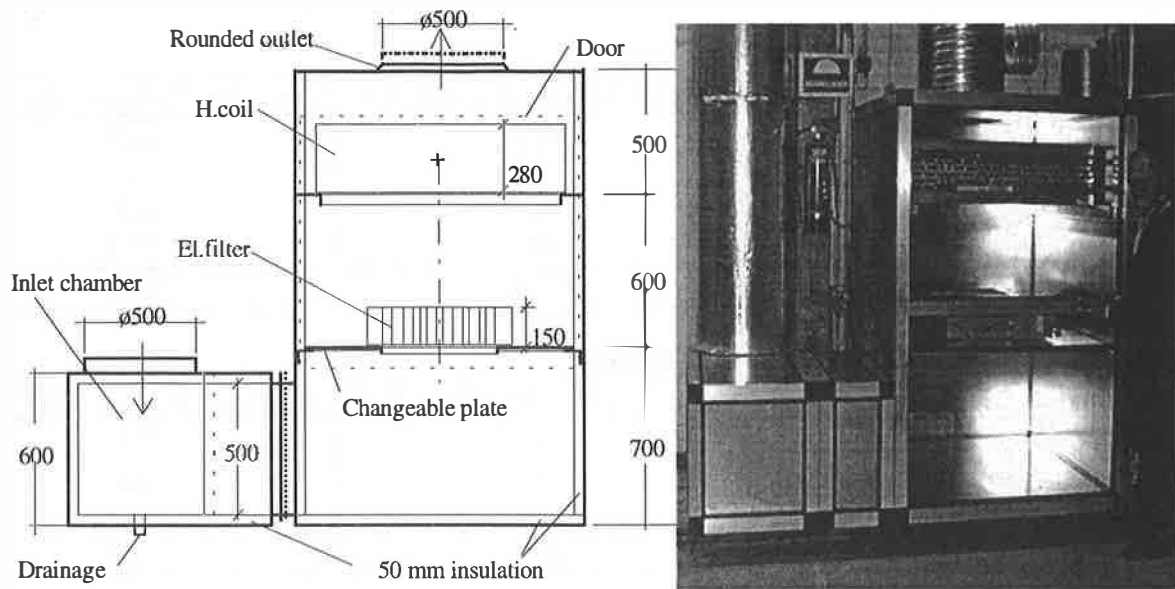

Fig. 2.3. Floor unit (indoor)

2.2. Pressure drops in the system

Dimensions and flow cross sections in a natural ventilation system must be chosen in order to keep the pressure losses as low as possible. Air velocities must be chosen to comply with the pressure loss requirements. The magnitude of the dynamic pressure ahead of components producing high pressure losses should be between 0,4 and 4 Pa (0,8 - 2,6 m/s air velocity), with the highest velocities in the supply terminals and exhaust openings. The lowest velocities should be applied where high resistance coefficients are expected such as sudden area enlargements, heat exchangers, filters, bends etc. The pressure drop in straight ducts can have an order of magnitude value of 0,15 Pa/m duct length, resulting in an air velocity of 1 m/s in Ø125 mm ducts increasing to 2 m/s in Ø400 mm ducts and even 4 m/s in Ø1000 mm ducts. Aerodynamically good shapes should be applied to avoid sudden area changes and sharp bends.

The pilot system is designed with approximately 2 m/s in the main, vertical ducts and 1 m/s in the smaller, horizontal ducts. This gives approximately designed pressure drops as listed in table 2.1 at nominal flow, 400 l/s:

Table 2.1. Design pressure drop for pilot system

Component	Supply system Δp [Pa]	Exhaust system Δp [Pa]
Air intake grille / exhaust wind vane	4	5
Heat exchangers	6	6
Filters	2	2
Air terminals	6	6
Ducts, bends, take-offs, etc	10	6
Sum	28	25
Total for supply and extract	53	

In addition to the pressure drops in table 2.1 the assisting fan gives about 4 Pa when it is turned off.

The pressure drops in the pilot system were also measured. Corrected pressure drop recalculated to be valid for a flow rate of 400 l/s are shown in table 2.2, supply and table 2.3, exhaust.

Table 2.2. Corrected pressure drop (loss). Supply

Component	Corrected for stack effect, Pa	Corrected for flow rate, Pa
Intake and vertical duct	10,5	11,3
Filter	1	1
Heat exchanger	6	6,5
Supply ducting and terminals	18	19,4
Total sum	35,5	38,2

Table 2.3. Corrected pressure drop (loss). Exhaust

Component	Corrected for stack effect, Pa	Corrected for flow rate, Pa
Outlet to atmosphere	2	1,2
Heat exchanger	5	3,1
Exhaust ducting and terminals	11,7	8,4
Total sum	20,7	12,7

Total system pressure drop, supply and exhaust: ≈50,9 Pa

The total pressure drop is quite near the design pressure drop, but the distribution between supply and exhaust is different.

The pressure drop in the supply system is higher than necessary due to a not optimised design and adaptation to the existing building.

2.3. Costs

The installation cost for the pilot system and anticipated cost for a similar future system with the volume flow of 0,4 m³/s are calculated. The yearly running cost for such a ventilation system is predicted taken the results from the measurements of the energy consumption into account. The same procedure is used for a traditional ventilation system by obtaining the installation cost from a ventilation entrepreneur company. The result from this comparison was that the installation cost for the pilot system was slightly higher than a traditional system but the running cost was lower in spite of the low heat recovery efficiency in the pilot system. A comparison of the “present value” based upon 20 years of operation showed approximately the same value for the two systems.

There are many uncertainties associated with these calculations e.g. cost of a comparable traditional system, future electricity price, present contra future price of the pilot system, cost of the “lost floor area” etc. The performed calculation shows however that a pilot system with heat recovery as presented here is competitive.

3. MEASUREMENTS

3.1 Temperatures, wind and air flow in the system

The winter in Oslo was extremely mild in February-98, but seasonally cold in March and April. After an initial measuring period in February, continuous logging has occurred since the last week of February. In the beginning different system modes were tested during some days: Natural ventilation without fan, natural ventilation with extract fan mounted but turned off and at last natural ventilation with assisting extract fan and regulation of fan speed.

Fig. 3.1 shows some selected data series from the first period, before the fan was installed.

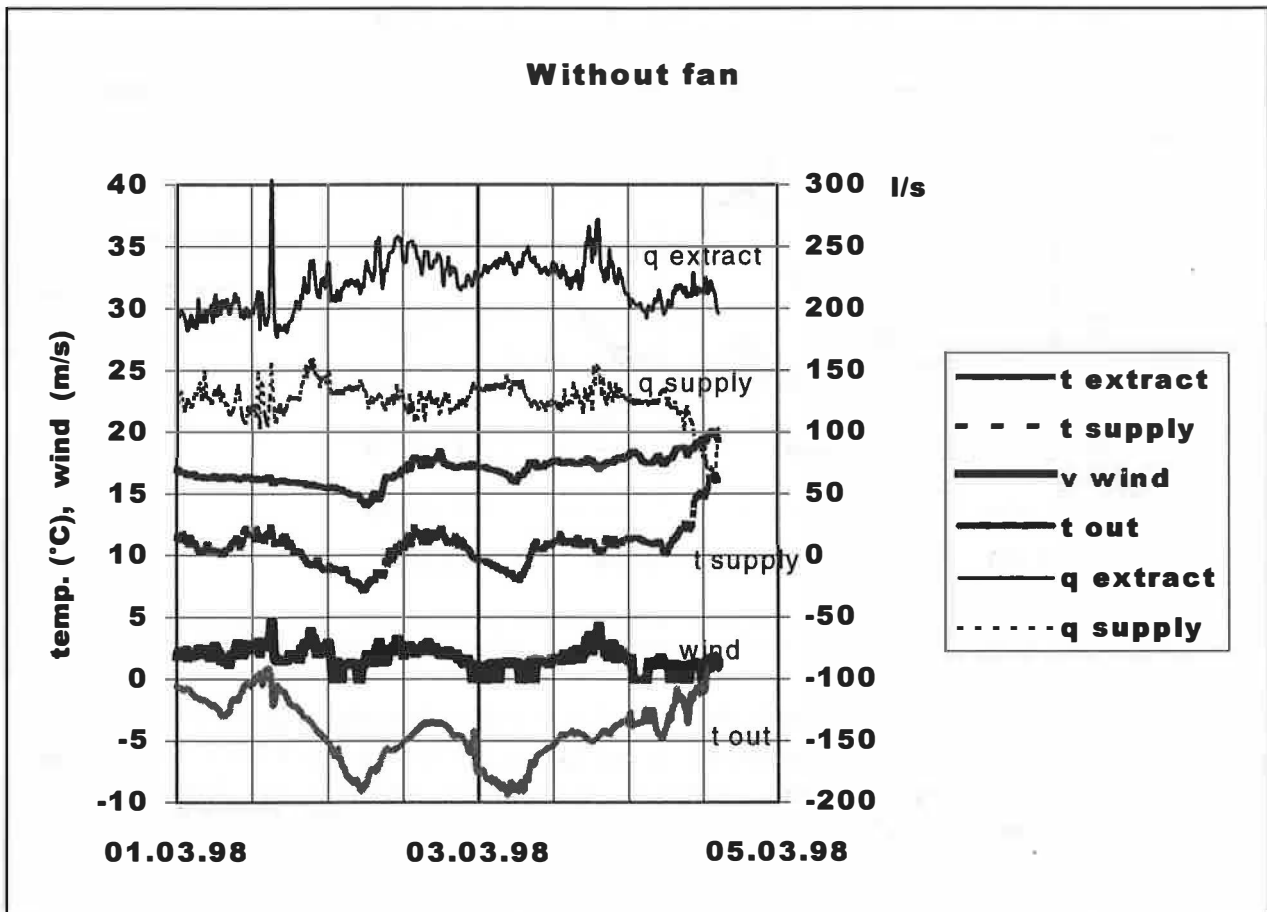

Fig. 3.1. Measurement results without assisting fan installed

The outdoor temperature in this period varied from -10°C to 0°C , and the wind speed from 0 to 5 m/s, (wind speed lower than 1 m/s can not be measured and is registered as 0). The extract air flow was around 60% of design value (~ 240 l/s) and the supply air flow around 33% of design value (~ 133 l/s). The heat recovery system increased the supply temperature about 15° .

Fig. 3.2 shows the same data series from a period with the extract fan mounted, but without electric connection, i.e. the fan is rotating because off the natural air flow.

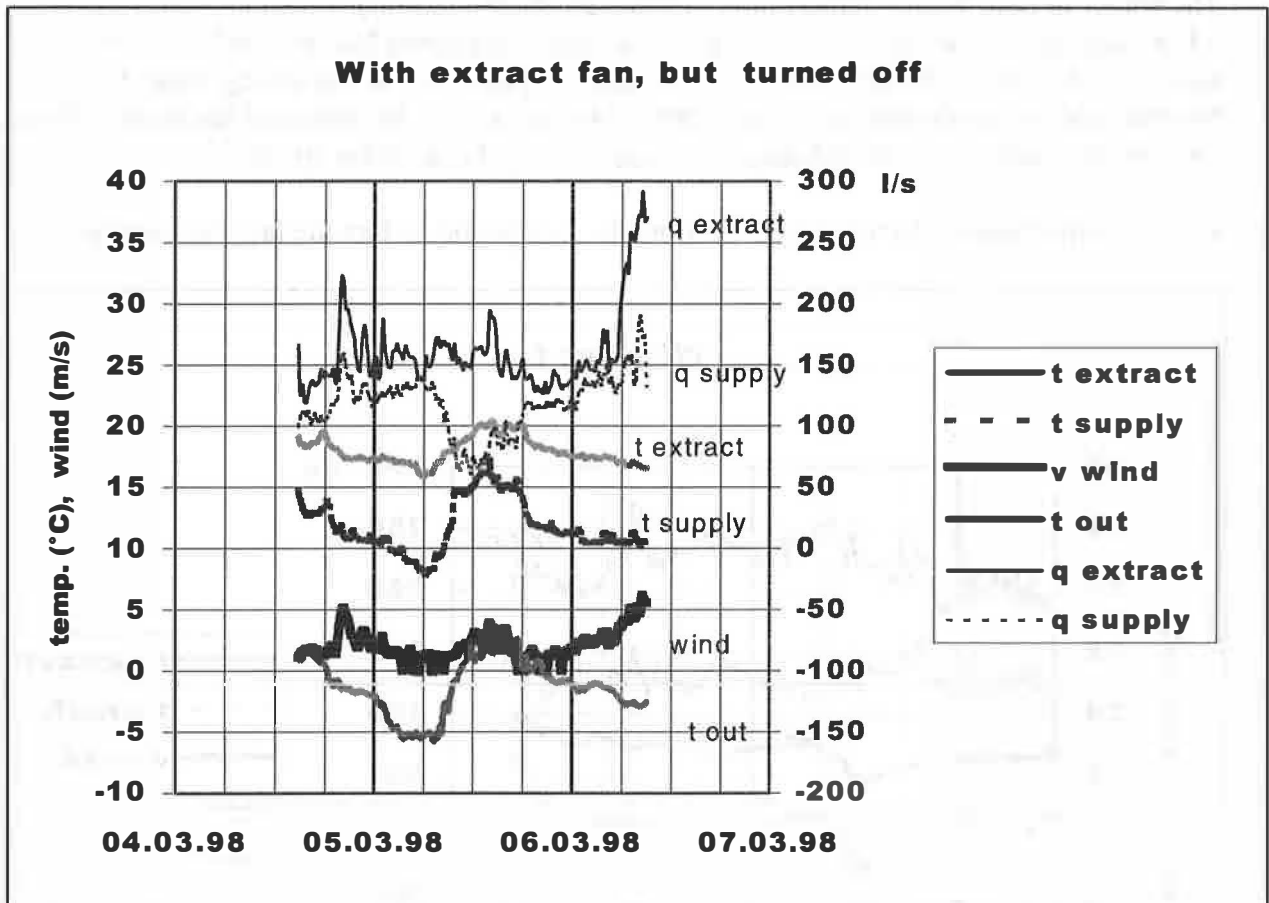

Fig. 3.2. Measurement results with installed assisting fan, but without electric connection

The outdoor temperature and wind in this period were about the same as in the period without fan. The extract air flow is now reduced to about 43% of design value (~170 l/s) and the supply air flow is about the same as before. There is a clear connection between the air flows and outdoor temperature and wind. The air flows increase considerably when the wind speed exceeds 5 m/s.

Fig. 3.3 shows the result of connecting the fan and fan control system. The extract air flow is now quite stable at design value (400 l/s), regardless of variations in wind and outdoor temperature. The supply air flow still varies with the natural driving force, but has increased to about 38% of design value (~150 l/s), due to increased extraction flow.

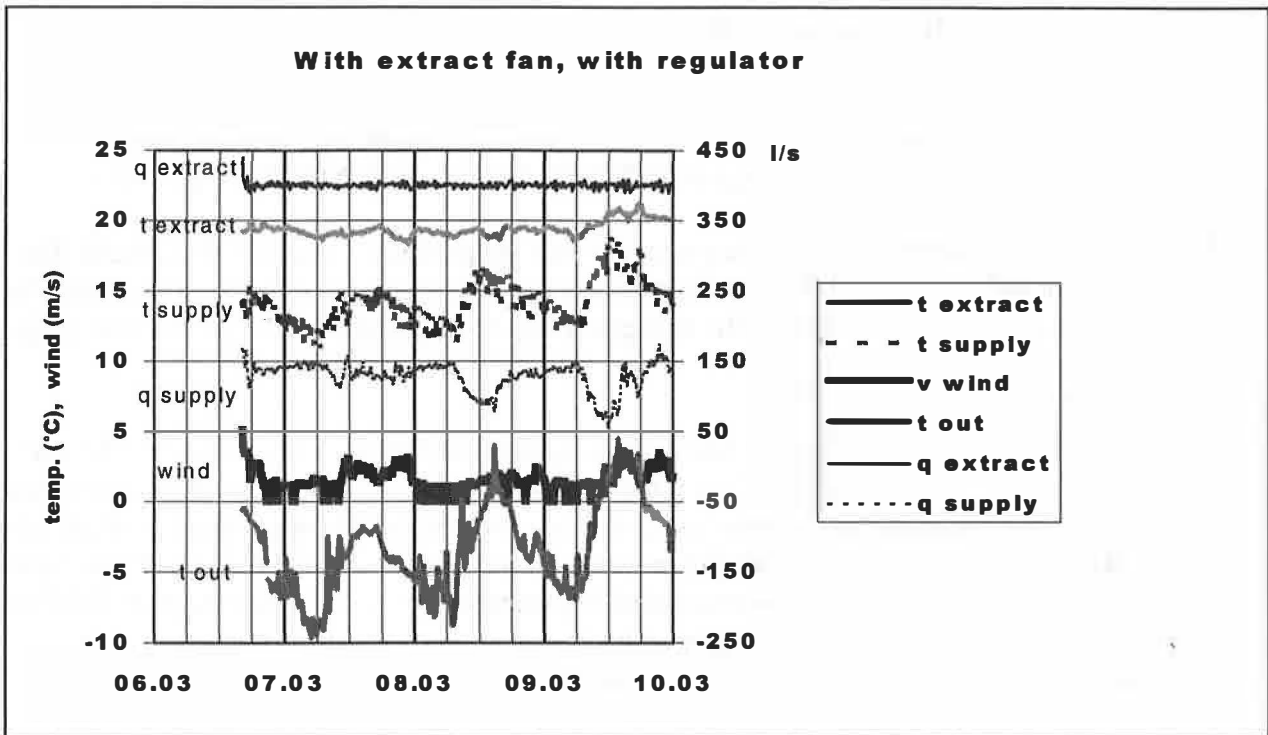

Fig. 3.3. Measurement results with assisting fan and with speed regulator

3.2. Heat exchanger efficiency

The heat exchanger efficiency is calculated from measurements in a period with an auxiliary supply fan installed, fig. 3.4. In the days from April 3. to April 6. the supply flow was kept reasonably constant at design flow (400 l/s). (The auxiliary fan had no automatic flow controller).

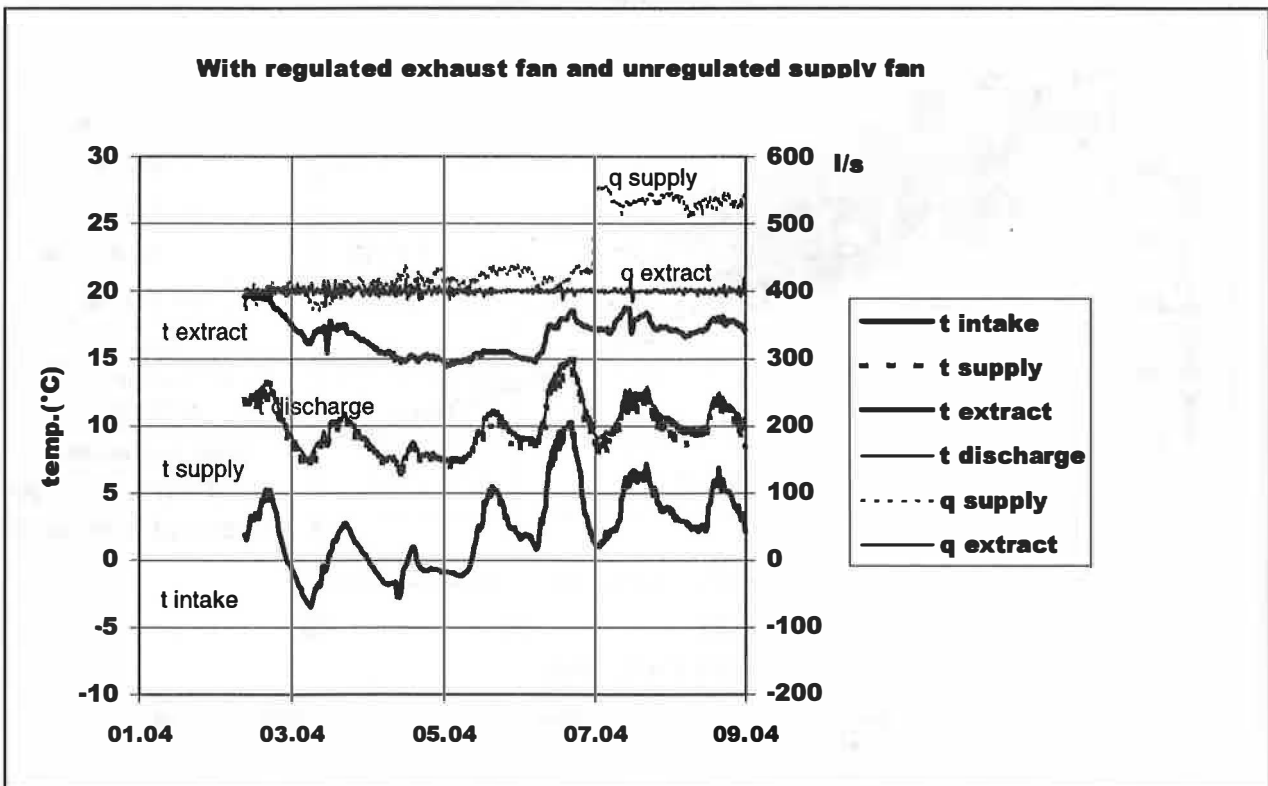

Fig. 3.4. Measuring results for calculation of heat exchanger efficiency

The heat exchanger efficiency is calculated with data from 04.04.98 at 06.59:

Suppl.=7,63°C, intake=-1,71°C, extr.=16,83°C *), disch.=7,73°C, $q_{\text{suppl}}=400$ l/s, $q_{\text{extr}}=405$ l/s.

$$\eta_{\text{suppl}} = (q_{\text{suppl}}/q_{\text{extr}}) \cdot ((t_{\text{suppl}}-t_{\text{int}})/(t_{\text{extr}}-t_{\text{int}})) = (400/405) \cdot ((7,63- -1,71)/(16,83- -1,71)) = 0,50$$

$$\eta_{\text{extr}} = (q_{\text{extr}}/q_{\text{suppl}}) \cdot ((t_{\text{extr}}-t_{\text{disch}})/(t_{\text{extr}}-t_{\text{int}})) = (405/400) \cdot ((16,83- 7,73)/(16,83- -1,71)) = 0,50$$

The measured heat exchanger efficiency is lower than the producer's design value, =0,58. The reason may be uneven flow over the coils, specially on the extract side, because of too little filter opening in front of the coil. This will be changed if the measurements continue in a new project.

3.3 Recording of fan power

The electric energy consumed by the assisting fan is measured with a kWh-meter and the data collected in a data logger. Because of the relatively high measuring resolution of the kWh-meter, the average values over periods as short as 15 min are not well suited for calculation of actual fan power. Instead we have calculated the fan power from the 15-min average of fan voltage, which is proportional to the fan speed. The connection between fan power and fan voltage at 400 l/s is determined from laboratory tests, see appendix 1:

$$P \text{ (W)} = 0,375 \cdot U \text{ (V)}^3 + 9 \quad (\text{including the regulator})$$

Fig. 3.5 shows how the fan power consumption varies with the natural driving force in the exhaust system. The driving height is here set to 16 m and the wind coefficient equal to 0,6. The figure contains measured 15 min data from the period March 6. to April 23.

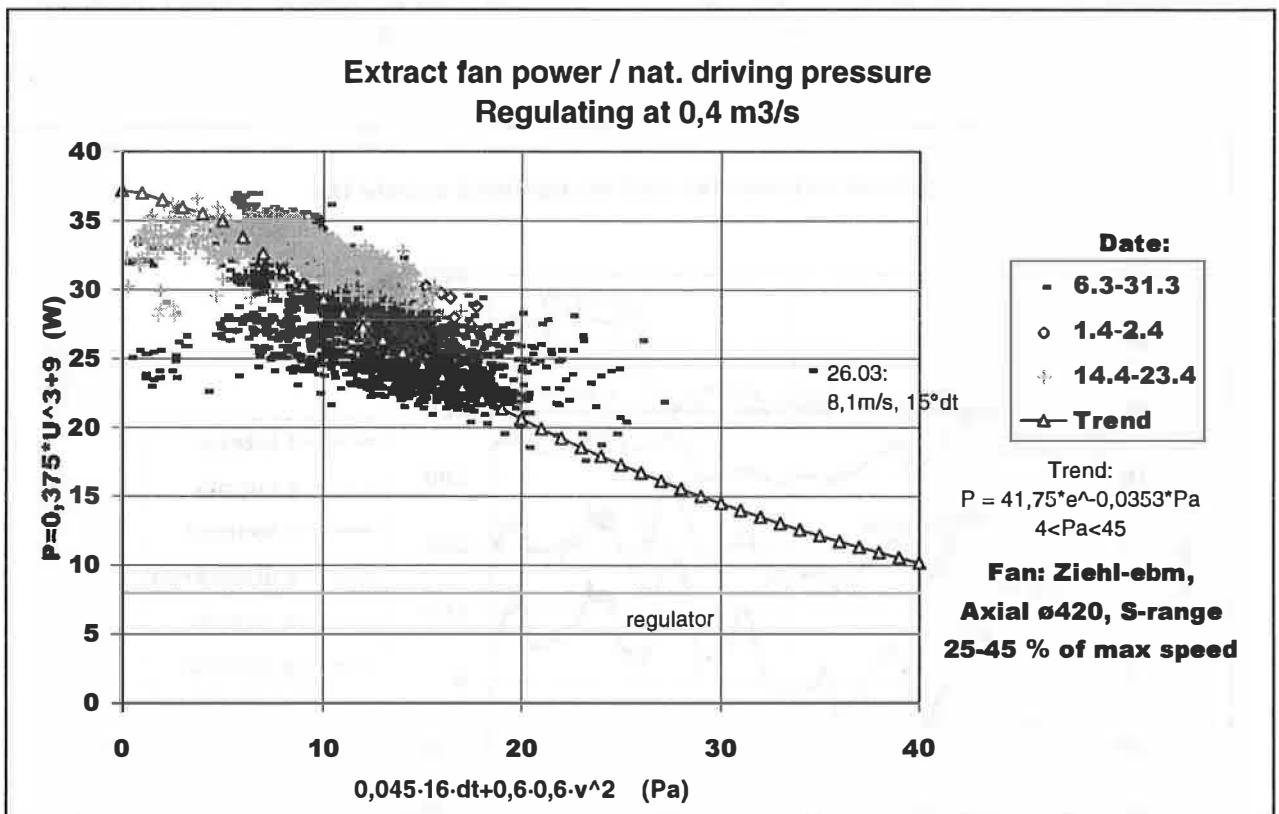

Fig. 3.5. Measuring results: Extract fan power consumption depending on natural driving pressure

The measured values in fig. 3.5 are quite spread out, mainly because of the 15 min averaging. There is no momentary connection between air flow, fan voltage, temperature difference and wind.

However, the trend is quite clear: The power consumption of the extract fan varied between 37 W and 18 W, depending on the natural driving pressure which varied from 0 to 23 Pa for this period.

4. DISCUSSION

In cold climates heat recovery in ventilation systems is necessary both for achieving thermal comfort and for saving energy. This is also the case with natural ventilation. Because of the low natural driving forces it is necessary to use assisting fan to get sufficient flow through the heat recovery system. A test system based on this principle was built in the laboratory at NBI. The objective was to get experience with such a system and to supply the NatVent project with measuring data.

The wind boosted air intake shutters and exhaust opening with wind vane improved the natural driving forces and thus reduced the fan energy consumption. This is demonstrated by the continuous measurement of fan power consumption, which varied with wind and temperature difference. In the recorded spring period the average fan power was about 75 % of the power needed when the driving forces are zero (no wind, no temperature difference).

The calculated driving forces acting on the system are:

Temperature driving pressure = $0,045 \cdot H \cdot dt = 0,72 \cdot dt$ (Pa). (H=16m).

Wind driving pressure, exhaust = $c \cdot p_{dyn} = 0,6 \cdot 0,6 \cdot v^2 = 0,36 \cdot v^2$ (Pa). (v= wind speed, m/s)

Wind driving pressure, supply = $c \cdot p_{dyn} = 0,6 \cdot 0,6 \cdot v^2 = 0,36 \cdot v^2$ (Pa). ($c_{suppl} \approx c_{exh}$)

In Oslo the wind speed seldom exceeds 5 m/s, therefore the temperature force is normally more important in the heating season.

Another important reason to have wind boosted intake and exhaust devices is to ensure that the flows goes in the correct direction through the system. Never the less there was one day in which there was reverse flow in the supply duct, due to an open door, and the reverse flow continued many hours after the door had been closed. The wind speed was however less than 2,5 m/s in this period.

In climate zones like in Oslo, with low wind speed, the benefit of the wind boosted intake and exhaust openings can be questioned. The cost for these devices can be higher than the energy they save during expected life time. Without these devices the system in principle is more like a traditional balanced system, but designed for very low pressure drop and arranged to use the natural temperature driving force.

It was anticipated that the assisting fans could be used as flow controllers. The tests confirmed that this function was very efficient.

There is no audible noise from the system. Because of the low pressure drop and the fans running on less than 50% of maximum speed, the fan noise is very low.

The installation cost for a future system similar to the tested pilot system has been calculated, with the assumption that the future system can be produced in series and installed in many wings of a new building. But even then the new system costs more than a traditional, balanced system, because of bigger duct- and component- dimensions per m^3/s air flow, and more lost floor area. This will also depend on how well the system is integrated in the building construction, i.e. the co-operation between the architect and the rest of the design team is important.

But the running cost is lower for the new system, because of low electric energy consumption by the fan. At the moment the lower running cost can not compensate for the higher installation cost, calculated with actual Norwegian energy prices. The Norwegian price of electricity is however anticipated to increase more than other prices, and therefore the total cost of the new system may be the lowest in the future.

5. CONCLUSIONS

Practical concepts for natural ventilation with heat recovery have been developed. A test system designed for an air flow rate of 400 l/s was evaluated in the laboratory at NBI. The system consists of:

- Roof unit with heat exchanger, coarse filter, assisting fan, a wind-boosted air exhaust unit and a wind-boosted air intake unit.
- Floor unit with electrostatic filter, heat exchanger, and an assisting fan
- Duct system. Exhaust air ducting with exhaust terminals in three levels. Supply air ducting in three levels with supply terminals (simulated with dampers). As a part of the supply system an insulated vertical main duct connects the air intake of the roof unit with the floor unit. The supply air may also be taken from ground level outside the building through an underground culvert (channel).
- A flow controller controlling the speed of the fans.

The total pressure drop for the system (supply and exhaust) is approx. 50 Pa. There is room for a reduction in pressure drop between 10 and 20 Pa by optimisation of the duct design.

Maximum power consumption for the extract fan is about 37 W, but has been measured as low as 18 W, when the natural driving force is higher.

The tests show that the laboratory building is quite leaky and that reverse flow can occur when the door is left open for a while. Therefore it was decided to install an assisting fan also in the supply system. In a very tight building it should be sufficient with one fan (in the exhaust).

Average power requirements for two assisting fans is about $2 \times 28 \text{ W} = 56 \text{ W}$. This gives a Specific Fan Power (SFP) = 0,14 kW/m³/s, which is about 5% of a typical system today.

The system may run with the assisting fans turned off, but generally with reduced air flow rate. The fan speed control system controls the air flow rate very efficiently.

The temperature efficiency for the heat recovery is measured to 0,50. With an optimal design of the installation the efficiency will increase to about 0,60.

The installation cost of the system is higher and the running cost is lower than for a traditional balanced ventilation system. The total cost over the lifetime depends on the future price of electricity and how well the system is integrated into the building.

6. REFERENCES

- /1/. E. Skåret, T. Hestad, P. Blom. Heat recovery in natural ventilation design of office buildings. NatVent, National Report 25, Norway. NBI, Oslo March 27, 1998.
- /2/. E. Skåret, T. Hestad, J. Brunsell. Heat recovery in natural ventilation design of office buildings. Measurements on a pilot system. NatVent, National Report 28, Norway. NBI, Oslo June 4, 1998.

7. CONTRIBUTORS

Auranor as, P.O.Box 100, N-2760 Brandbu: Dampers, discount on exhaust wind vane.
Ziehl-ebm as, P.O.Box 173 Holmlia, N-1203 Oslo: Assisting fans with regulators, intake louvers.
Oddbjørn Hagen AS, P.O.Box 263 N-2381 Brumunddal,: Mounting of ducts, equipm., insulation.
Nor-Vent AS, Prof. Birkelandsv. 35, N-1081 Oslo: Discount on ducts and fittings.
NVP, Industriveien, 2072 Dal: Discount on chambers.
ABB Klimaprodukter, Odalsg. 25, N-2001 Lillestrøm: Discount on heat exchanger coils.
MiljøSystemer A/S, P.O.Box 341 Økern, N-0513 Oslo: Discount on electrostatic filters.
Proff Utleie A/S, Strømsv.226, N-0668 Oslo: Discount on scaffolding.
Ing. Wilberg a.s, P.O.Box 6424 Etterstad, N-0605 Oslo: Discount on velocity sensors.
Norsk Ventilasjon og Energiteknisk Forening, P.O.Box 7174 Majorstua, N-0307 Oslo:
 Travelling expenses and fee for one project person on 3 seminars about the project.
Norges forskningsråd, Nytek, P.O.Box 2700 St. Hansh., N-0131 Oslo: Project grant.
Statsbygg, Postboks 8106 Dep., 0032 Oslo: Project Grant
NVEs Byggoperatør, Dr. ing. Ole-Gunnar Søgne, Valkendorfsgt. 9, 5012 Bergen: Project grant.
Oslo Energi Enøk,, Postboks 2481 Solli, 0202 Oslo: Project grant

