

Performances of a simple exhaust mechanical ventilation coupled to a mini heat pump: modeling and experimental investigations

Frédéric Ransy*¹, Samuel Gendebien¹ and Vincent Lemort¹

*1 University of Liege, Thermodynamics Laboratory
Quartier Polytech 1
Allée de la Découverte, 17
4000 Liège, Belgium*

**Corresponding author: Frederic.ransy@ulg.ac.be*

ABSTRACT

Nowadays, important efforts are deployed to reduce energy consumption in the field of residential buildings. Concerning new constructions, low-energy consumption buildings such as “passive” houses constitute a suitable solution to decrease the environmental impacts.

In this kind of building, air tightness is improved and heating needs are reduced compared to traditional constructions. In order to ensure a good indoor air quality, controlled mechanical ventilation is required. Coupling a simple exhaust mechanical ventilation with a mini-heat pump appears to be a good solution for heat recovery.

This latter system could provide an important (and even the whole) part of the heating demand related to domestic hot water. The system can also be coupled to the heating system of the building. Investigation on this system is carried out in the present paper.

The first part of the paper presents the system, its components and its control. A semi-empirical numerical model of the whole system is presented. This model associates the sub-models of the main components: the compressor, the condenser, the evaporator (in this case, the ventilation heat recovery heat exchanger), the domestic hot water heat exchanger and the domestic hot water storage tank.

The second part of the paper describes the experimental apparatus (and its control) designed to characterize the performance of the system in different operating conditions.

Experimental data are presented and analyzed, which includes a calibration of the parameters of the model and a comparison with simulation results.

Finally, the model is coupled to a building simulation model to determine the potential savings of such units.

KEYWORDS

Simple exhaust mechanical ventilation, heat recovery, heat pump, experimental tests, building simulation

1 INTRODUCTION

According to the European directive 2012/27/EU of October 2012 on energy efficiency, buildings represented 40 % of the EU’s final energy consumption in 2011. The major part of this energy consumption is due to the residential sector for space heating and domestic hot water production. Moreover, buildings are crucial to achieve the EU objective of reducing greenhouse gas emissions by 80-95 % by 2050 compared to 1990.

In order to reduce these greenhouse gas emissions, retrofit measures regarding insulation and air-tightness have to be taken. However, such improvements of the building envelope lead to a relative increase in consumption related to ventilation. Indeed, according to Orme (2001), Roulet et al. (2001) and Fouih et al. (2012), the heating demand due to ventilation can reach more than 50 % of the total building heating demand for new and retrofitted buildings.

To reduce the energy consumption due to ventilation, exhaust air heat pumps (EAHPs) can be used instead of the traditional heat recovery with an air-to-air heat exchanger. EAHPs recover heat from the exhaust air of the ventilation system to produce domestic hot water and space heating. According to Fehrm et al. (2002), this technology is already widely used in the northern countries such as Germany and Sweden. In fact, according to Fracastoro et al. (2010), efficiencies of EAHPs are higher than those obtained with outside air or geothermal heat pumps in certain conditions, whatever the climate location. Berg et al. (2010) have monitored three houses in Sweden equipped with exhaust air heat pumps. The seasonal performance factor (SPF) values were all within the range 1.4-1.7. This factor takes into account the energy consumption of the heat pumps and the auxiliary heating systems. A 17 kW exhaust air heat pump has also been tested by Mikola et al. (2014). The measured SPF for the heat pump only (without taking into account the auxiliary heating system) was about 2.9-3.4 in winter and 3 in the summer.

Exhaust air heat pumps coupled with simple exhaust mechanical ventilation systems have many advantages compared to traditional balanced systems with heat recovery:

- Only one fan is necessary and the duct system is simpler. Consequently, EAHPs are suitable for retrofitted buildings.
- The heat pump can provide the whole part of the heating demand related to domestic hot water and 50 % of the heating demand related to space heating, according to Fracastoro et al. (2010).
- The heat pump can also provide active cooling by inverting the refrigerating cycle.
- The heat pump performance is high and remains constant with outdoor temperature changes since the temperature of the heat sink is constant (20°C). As a result, the system is cost-effective.
- The system is compact, quiet and requires little maintenance.

In the present paper, the energetic performances of an exhaust air heat pump are assessed through numerical and experimental studies. The thermal capacity of the machine is 1.5 kW when the inside air temperature is 20°C and the outside water temperature is 35°C. The heat pump is therefore ideally suited for new or retrofitted buildings. The system including a mechanical exhaust ventilation system and an exhaust air heat pump is first presented. Secondly, the heat pump model used afterwards to determine the heat pump seasonal performance factor is described. Thirdly, the model is calibrated to fit the measurement data. Finally, the heat pump model is coupled to a building model to determine the annual performance of the system. The system is compared to a traditional balanced ventilation system with heat recovery in terms of primary energy consumption, for different heating and DHW production systems (electric heater, heat pump, gas condensing boiler).

2 DESCRIPTION OF THE SYSTEM

The system is composed of a mechanical exhaust ventilation with natural air supply and an air-to-water heat pump for heat recovery purpose. The air side of the heat pump is connected to the exhaust duct of the ventilation system, while the water side is connected to a hot water storage tank. If necessary, it can be also connected to the heating circuit of the building. The schematic diagram of the system is shown in **Error! Reference source not found.**

The main components of the exhaust air heat pump investigated in this paper are shown in Figure 2 and described below.

- The compressor (CP in Figure 2) is an air cooled and hermetic rotary compressor working with R134a. Its control is a simple ON/OFF switch.
- The condenser (CD in Figure 2) is a water/refrigerant plate heat exchanger with a nominal water flow rate of 400 l/h. This exchanger has been chosen for its high efficiency, high compactness and low price.

- The evaporator (EV in Figure 2) is an air/refrigerant finned-tube heat exchanger with a nominal air flow rate of 215 m³/h. This exchanger has been chosen for its good efficiency due to its high heat-exchange area and low price.
- The thermostatic expansion valve maintains the evaporator overheating constant (5K).
- The internal heat exchanger (IHE in Figure 2) is a simple refrigerant/refrigerant heat exchanger. The tubes are simply welded to realize a heat transfer by conduction. This welding provides a small overheating before the supply of the compressor to avoid the presence of liquid. The effect of this exchanger on the performance of the machine is negligible. For this reason, the modeling of the internal heat exchanger is not considered in this paper.
- The auxiliary equipments are the exhaust fan and the pump in the secondary water loop. The fan speed can be modified in order to provide the desired volume flow rate. On the other hand, the water pump rotation speed is constant. The pump is just turned off when heating capacity is not needed.

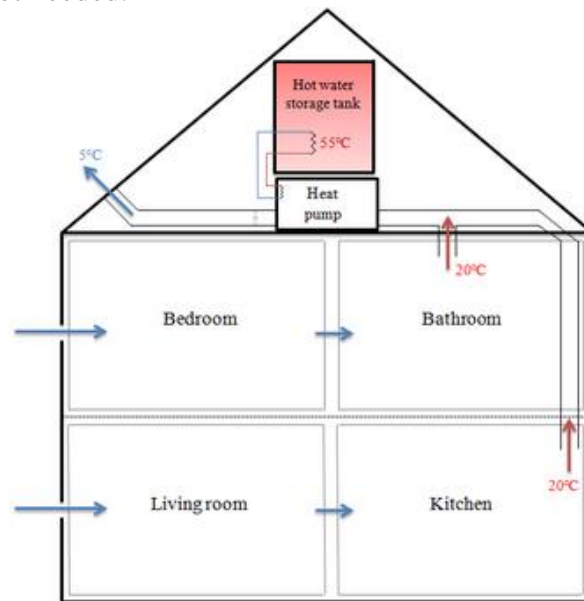

Figure 1: Schematic diagram of the system

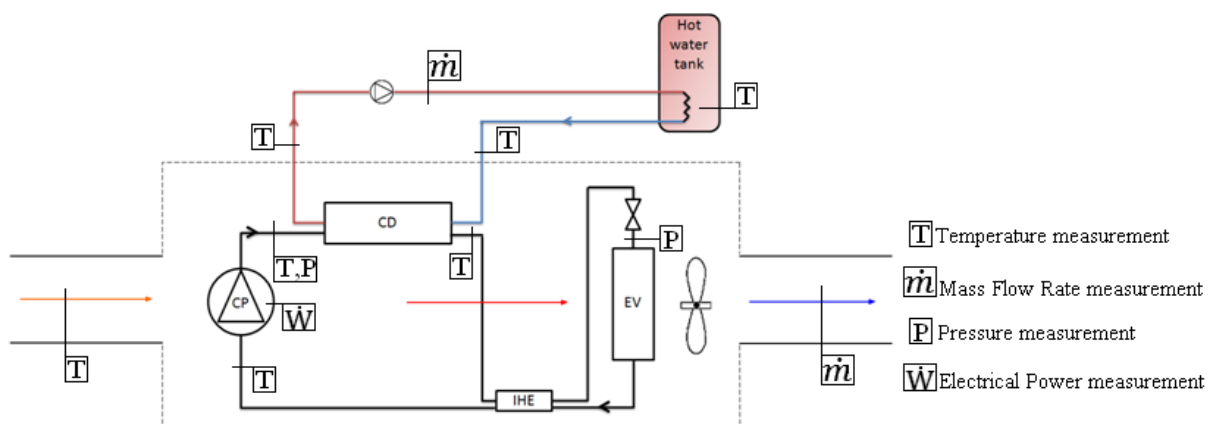

Figure 2: Schematic diagram of the heat pump

3 DESCRIPTION OF THE HEAT PUMP MODEL

A semi-empirical numerical model of the heat pump has been developed to determine its seasonal performance factor. Based on an identification of the components parameters based

on experimental data, the model is able to predict the COP and the electrical consumption of the compressor. The objective is to predict, with a model as simple as possible, the performances with a maximum relative error of 5%. The heat pump is modeled in steady-state conditions whereas a dynamic model is used for the temperature evolution inside the water tank.

3.1 Compressor model

The compressor is described with three parameters: the swept volume V_s [m³], given in the compressor datasheet, the isentropic efficiency ε_{is} and the volumetric efficiency ε_v . The swept volume and the volumetric efficiency determine the refrigerant mass flow rate imposed by the compressor. The isentropic efficiency determines the compressor electrical consumption. The swept volume V_s is equal to 12.75 cm³.

The maximal refrigerant volume flow rate $\dot{V}_{s,cp}$ passing through the compressor depends on the rotational speed and the swept volume of the compressor, as given by equation ((1):

$$\dot{V}_{s,cp} = \frac{N}{60} V_s \quad (1)$$

Due to the pressure drop at the compressor supply, the presence of the dead volume and internal leakage, the real volume flow rate $\dot{V}_{r,cp}$ is lower than the maximal refrigerant mass flow rate calculated by equation (1). It depends on the volumetric efficiency of the compressor and is calculated by equation (2):

$$\dot{V}_{r,cp} = \dot{m}_{r,cp} v_{r,su,cp} = \varepsilon_v \dot{V}_{s,cp} \quad (2)$$

The specific volume $v_{r,su,cp}$ depends on the refrigerant pressure and temperature at the supply of the compressor.

The isentropic efficiency ε_{is} is used to take into account the thermal losses and the electrical motor efficiency. It is the ratio of the isentropic compressor consumption to the electrical compressor consumption, as given by equation (3):

$$\varepsilon_{is} = \frac{\dot{W}_{cp,is}}{\dot{W}_{cp,el}} = \frac{\dot{m}_{r,cp}(h_{r,ex,cp,is} - h_{r,su,cp})}{\dot{W}_{cp,el}} \quad (3)$$

with $h_{r,ex,cp,is}$ the isentropic specific enthalpy at the outlet of the compressor and $h_{r,su,cp}$ the specific enthalpy at the supply of the compressor.

As explained by Cuevas et al. (2010), the isentropic and volumetric efficiencies depend on the pressure ratio r_p which is the ratio of the condensing pressure to the evaporating pressure. In this paper, as proposed by Wenhua (2013) and Ouadha et al. (2008), the two efficiencies are estimated by polynomials forms given in equations (4) and (5):

$$\varepsilon_{is} = \alpha_0 + \alpha_1 r_p + \alpha_2 r_p^2 \quad (4)$$

$$\varepsilon_v = \beta_0 + \beta_1 r_p + \beta_2 r_p^2 \quad (5)$$

The parameters in equations (4) and (5) have been determined using measurement data. The calibration of these parameters is described in the next section.

3.2 Heat exchanger model

Each heat exchanger is described using one parameter: the global heat transfer coefficient AU at nominal conditions. This coefficient determines the heat exchanger efficiency. The exchangers are considered to be semi-isothermal and are modeled with the epsilon-NTU method. **Error! Reference source not found.** gives the different fluids circulating in the three exchangers, for the isothermal and the secondary fluid sides.

Table 1: Isothermal and secondary fluids for the three exchangers

	Condenser	Evaporator	Domestic hot water heat exchanger
Fluid 1 (isothermal side)	Refrigerant	Refrigerant	Water inside the tank
Fluid 2 (secondary fluid)	Water (secondary water loop)	Exhaust air from ventilation	Water (secondary water loop)

The exchangers are described with the equations ((6), (7) and (8):

$$\dot{Q} = \dot{m}_{iso} (h_{su,iso} - h_{ex,iso}) \quad (6)$$

$$\dot{Q} = \dot{m}_{sec} (h_{ex,sec} - h_{su,sec}) \quad (7)$$

$$\dot{Q} = \varepsilon \dot{m}_{sec} cp_{sec} (T_{iso} - T_{su,sec}) \quad (8)$$

with \dot{Q} the heat flow exchanged between the two fluids, \dot{m}_{iso} and \dot{m}_{sec} respectively the mass flow rate of the isothermal fluid and the secondary fluid, $h_{su,iso}$ and $h_{ex,iso}$ the specific enthalpy of the isothermal fluid at the supply and the exhaust of the exchanger and $h_{ex,sec}$ and $h_{su,sec}$ the specific enthalpy of the secondary fluid at the exhaust and the supply of the exchanger. Equation (8) uses the definition of the exchanger efficiency ε . $\dot{m}_{sec} cp_{sec}$ is the thermal capacity of the secondary fluid. T_{iso} is the temperature of the isothermal fluid and $T_{su,sec}$ is the temperature of the secondary fluid at the supply of the exchanger.

The ε -NTU method is used to determine the exchanger efficiency. It depends on the global heat transfer coefficient and the secondary fluid heat capacity, as given by equation (9):

$$\varepsilon = 1 - \exp\left(\frac{-AU}{\dot{m}_{sec} cp_{sec}}\right) \quad (9)$$

3.3 Expansion valve model

The thermostatic expansion valve model supposes an isenthalpic expansion and it is also assumed that the expansion valve imposes a constant superheat of 5K at the outlet of the evaporator.

3.4 Domestic hot water tank model

The domestic hot water tank is a sensible heat storage with water as medium used to dissipate the heat produced by the air exhaust heat pump.

The tank is modeled by a one-node model with the water tank temperature T_{tank} as state variable. The energy balance of the tank is given by equation (10):

$$\dot{Q}_{tank} = \dot{Q}_{cd} = \dot{U}_{tank} = m_{w,tank} \cdot cp_w \cdot \frac{dT_{tank}}{dt} \quad (10)$$

with \dot{Q}_{cd} the heat flux produced by the condenser of the heat pump, \dot{U}_{tank} the internal energy variation of the water inside the tank, $m_{w,tank} cp_w$ and T_{tank} the heat capacity and the temperature of the water inside the tank. The inside tank temperature $T_{tank}(t)$ is calculated by integrating equation (10) over time.

4 DESCRIPTION OF THE HEAT PUMP TEST BENCH

The test bench developed to calibrate the heat pump model is composed of an air-to-water heat pump connected to a 300 liters hot water storage tank. The heat pump is connected to the

tank through a secondary water loop in order to avoid any contact of the domestic hot water with the refrigerant.

Five input variables can influence the COP of the heat pump: the water mass flow rate at the condenser, the air mass flow rate at the evaporator, the water temperature inside the tank and the air temperature and humidity at the supply of the heat pump. The test set up is designed in order to have the possibility to change all these operating conditions. The water mass flow rate at the condenser can be adjusted with several valves of the hydraulic plant. The air flow rate can be modified by adjusting the rotational speed of the fan. The water temperature inside the tank can be kept constant. Moreover, it is also possible to heat the water inside the tank from 20°C to 60 °C only with the exhaust air heat pump. Lastly, the air temperature at the supply of the heat pump is kept constant for the duration of the test. The air humidity variation at the supply of the heat pump is not considered in this paper.

Different sensors have been placed on the test bench with the aim of determining the performances of the machine and calibrating the heat pump model. Figure 2 shows a schematic diagram of the test bench and the position of the different sensors.

Five types of sensors are used on the test bench: T-type thermocouples for the temperature measurements, absolute pressure sensors for the measurement of the condensing and the evaporating pressures, differential pressure sensors used for the airflow rate measurement, ultrasonic flowmeter for the water mass flow rate measurement at the condenser and electrical wall plug data loggers for electrical consumption measurements.

The measurement of the air volume flow rate is carried out with a nozzle connected to the exhaust duct on the air side of the heat pump. In fact, when the exhaust air flows through the nozzle, a pressure drop proportional to the volume flow rate appears. This pressure drop is then measured by a differential pressure, which allows to measure the air volume flow rate. Table 2 gives the accuracy of the different sensors used on the test bench.

Table 2: Accuracy of the different sensors used on the test bench

Thermocouples type T	Absolute pressure sensors	Differential pressure sensors	Ultrasonic flowmeter	Electrical wall plug data loggers	Air volume flow rate measurement
0.5K	0.15 % of the actual measurement	2.5 Pa	3 % of the actual measurement	1 % of the actual measurement	5 % of the actual measurement

5 EXPERIMENTAL RESULTS AND HEAT PUMP MODEL VALIDATION

Parameters of the heat pump model described in section 3 are calibrated using experimental data obtained with the test bench described in section 4. The parameters of the compressor and the heat exchangers are tuned to fit experimental data. One experimental test has been carried out. The tank has been heated with the exhaust air heat pump from 20°C to 60°C. During the test, the air flow rate at the evaporator, the water flow rate at the condenser, the air temperature and relative humidity were respectively equals to 215 m³/h, 400 l/h, 22°C and 50%.

5.1 Compressor model calibration

Figure 3 shows the experimental results for the volumetric and isentropic efficiencies of the compressor as a function of the pressure ratio (black lines). The refrigerant mass flow rate, used to determine the two efficiencies, is not directly measured because it is too small to get sufficient accuracy. The mass flow rate is determined using heating balances on the water and the refrigerant sides of the condenser.

The volumetric efficiency varies from 0.9 to 0.65 for a pressure ratio varying from 2.5 to 4.5. The isentropic efficiency varies from 0.53 to 0.42. The polynomial approximations (red lines)

fit very well the experimental data with coefficients of determination (R^2) of 99.02 % and 97.94 % respectively. The parameters of the polynomial laws are given in the Figure 3.

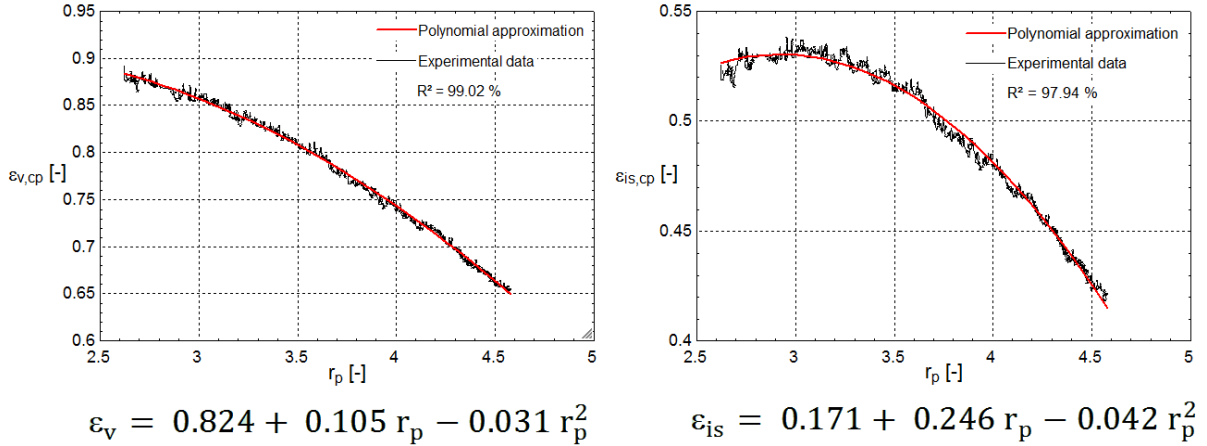

Figure 3: Polynomial approximations of the compressor volumetric efficiency (left) and isentropic efficiency (right)

5.2 Heat exchanger models calibration

For the heat exchanger models calibration, one water tank load has been carried out. The water inside the tank has been heated from 20°C to 60 °C by using only the exhaust air heat pump. During the test, the water mass flow rate was 400 l/h, the air volume flow rate was 215 m³/h and the air temperature at the supply was 22°C. The global heat transfer coefficients AU_{ev} , AU_{cd} and AU_{tank} for the three exchangers have been calculated using the least squares method. The method consists in minimizing the sum S given by equation (11):

$$S = \sum_{i=1}^n [y_i - f(x_i, AU_{ev,n}, AU_{cd,n}, AU_{tank,n})]^2 \quad (11)$$

with n the number of experimental points, y_i the measured COP for point number i and $f(x_i, AU_{ev}, AU_{cd}, AU_{tank})$ the COP calculated by the model for the corresponding experimental inputs x_i . The parameters obtained for the three heat exchangers are given in Table 3.

Table 3: Parameters of the three heat exchangers

AU_{ev}^* [W/K]	AU_{cd}^* [W/K]	AU_{tank}^* [W/K]
73	684	362

*for the following nominal conditions: $\dot{m}_{w,n} = 400$ l/h and $\dot{V}_{air,n} = 215$ m³/h

5.3 Model validation

The aim of the heat pump model described in section 3 is to predict the COP of the machine with an acceptable accuracy. Figure 4 shows the compressor electrical consumption and the COP of the machine as a function of the temperature of the water inside the tank. The blue lines represent the experimental results with the corresponding 5 % vertical error bars. The black lines represent the model predictions for the same inputs as those for the experimental tests.

As shown in Figure 4, the model is accurate within 5 % error, which is considered acceptable. As expected, the water temperature inside the tank has a significant influence on the COP of the heat pump. As a result, the set-point temperatures for domestic hot water production and space heating have an important impact on the seasonal performance factor of the exhaust heat pump.

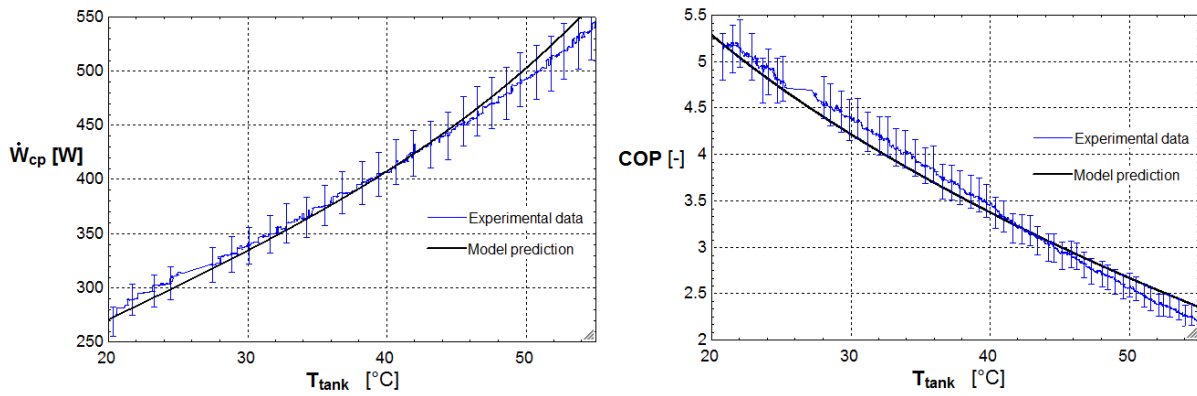

Figure 4: Compressor electrical consumption (left) and COP of the machine (right) (experimental data and model prediction)

6 DETERMINATION OF ANNUAL PERFORMANCES OF THE SYSTEM

In order to determine the annual performances of the system, the above heat pump model is combined with a dynamic building model. Then, the annual performances of the exhaust air heat pump coupled to the simple exhaust mechanical ventilation are compared to the performance of a balanced ventilation system with heat recovery.

6.1 Building model

The building model is the combination of a multizone thermal model and an airflow building model implemented in Modelica. The model is based on electrical analogy (Masy, 2008). For the thermal model, the temperatures and heat flows respectively correspond to electrical potential and current. The different walls of the building, the windows and the doors are modeled with thermal resistances and thermal heating capacities. Internal and solar gains are directly injected at the appropriate temperature nodes. For the airflow building model, the pressures and airflow rates respectively correspond to electrical potential and current. The pressures are imposed by the wind, the buoyancy effect and the fans (for mechanical ventilation). The components of the aeraulic circuit (doors, ducts, extract/supply grilles, etc...) are modeled with non-linear resistances (non-linear relation between pressure drop and mass flow rate). The fans are modeled with polynomial expressions fitted on manufacturer data.

The building model calculates the temperature and the pressure for each zone, and the mass flow rate between these zones. The mass flow rates entering and leaving the building due to the ventilation system and the infiltrations are also determined.

6.2 Case study

The case study, described by Laverge (2013), is a reference flat which represents an average dwelling in Belgium. The total floor area is 120.6 m² and the heated volume is 326 m³. The surface areas for the different rooms of the apartment are shown in Table 4.

Table 4: Surface areas of the different rooms of the flat building for one floor in m²

Bedroom1	Bedroom2	Bedroom3	Living room	Kitchen	Service room	Toilet	Bathroom	Hall
17.1	13.3	16.5	32.5	13.5	7.7	1.6	7.5	10.9

External walls are made of high density bricks (32 cm) insulated with 12 cm of polyurethane corresponding to a U-value of 0.22 W/m²K (K35). Internal walls are made of 20 cm of high density bricks and the floors are made of precast concrete. As a result, the dwelling has a high thermal inertia. Double-glazed windows with a U-value of 1.45 W/m²K and a g-factor of 0.6 are used. The infiltration rate is equal to 2.5 ACH at 50 Pa, corresponding to a typical value

for renovated flat (Gendebien et al, 2014). The case study is therefore a typical retrofit apartment building. The nominal ventilation mass flow rates for each room of the building, imposed by the Belgian standard NBN D50-001, are given in the Table 5.

Table 5: Nominal ventilation mass flow rates for each room of the building

	Bedroom1	Bedroom2	Bedroom3	Living room	Kitchen+ Service room	Toilet+ Bathroom
Nominal exhaust airflow rate [m ³ /h]	-	-	-	-	158	128
Nominal supply airflow rate [m ³ /h]	62	48	59	117	-	-

The set-point temperature is supposed 18°C in all the rooms and 21 °C in the living from 16 PM to 22 PM.

The domestic hot water tank is designed for a typical family of four people. The tank volume is 200 liters and the set-point temperature is 55°C. Domestic hot water profiles from the Annex 42 of the International Energy Agency (Knight, 2007) are used to model the hot water consumption.

Four cases are considered in this study. For all this cases, the ventilation system is supposed to operate continuously and is designed to deliver the ventilation mass flow rates given in Table 5 in nominal conditions. However, the supply and exhaust air flow rates can be influenced by weather conditions (wind, temperature).

- The first case considers a simple exhaust ventilation system coupled with an exhaust air heat pump producing domestic hot water. The heat pump is activated when the water temperature inside the tank is lower than 35 °C and is turned off when the set-point temperature of 55°C is reached. The heat pump can also be used for space heating when domestic hot water production is not necessary. In this case, a fan-coil unit with a supply water temperature of 45 °C is used. If the heat pump heating capacity is not enough compared to the building demand, a 3 kW auxiliary electrical heater is activated. Finally, according to Laverge et al. (2010), the specific fan power (SFP) of the exhaust fan is supposed to be 0.21 W/(m³-h).
- The second case considers a balanced ventilation system with an air-to-air heat exchanger for heat recovery. This exchanger is supposed to have a constant efficiency of 85 %. According to Laverge et al. (2010), the specific fan power (SFP) of each fan is supposed to be 0.35 W/(m³-h). For DHW production and space heating, a 5 kW electrical heater with an efficiency of 100% is used.
- The third case considers the same ventilation system than the one in case two, but DHW production and space heating are provided by a 5 kW outside air-water heat pump. The COP of this heat pump depends on the outside temperature. A simplified empirical model based on the Conslim method (Bolher, 1999) using manufacturer data is implemented to calculate the COP. A fan-coil unit with a supply water temperature of 45 °C is also used.
- The fourth case considers the same ventilation system than the one in case two, but DHW production and space heating are provided by a 5 kW gas condensing boiler. A constant boiler efficiency (based on the higher heating value) of 93 % is supposed.

6.3 Numerical results

The four cases are compared in terms of annual primary energy consumption. To convert electricity consumption to primary energy consumption, a primary energy factor (PEF) of 2.5 is used, which corresponds to the power generation efficiency of Belgium. Climate conditions corresponding to Brussels are chosen for the different simulations. Figure 5 shows the annual primary energy consumption for the four cases investigated.

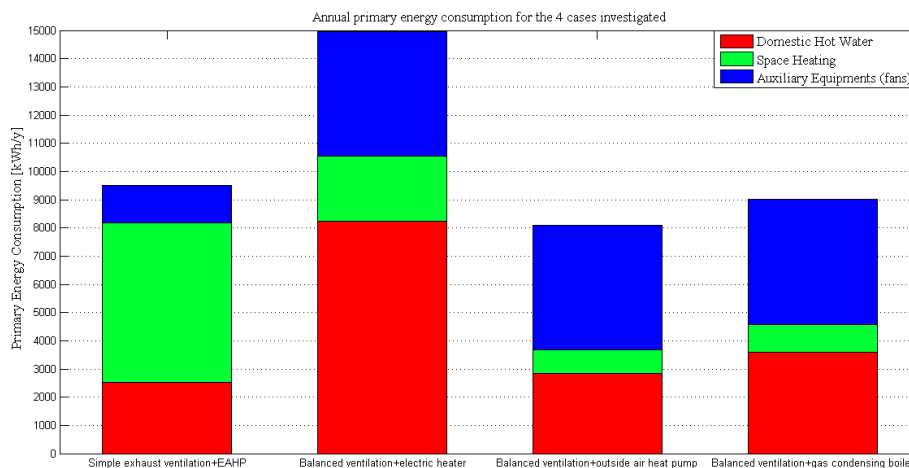

Figure 5: Annual primary energy consumption for the four cases investigated

The simple exhaust ventilation system coupled with an exhaust air heat pump is much more interesting than the balanced ventilation coupled with an electric heater. Indeed, in the case n°1, the seasonal performance factor for the domestic hot water production is 3.27, reducing significantly the primary energy consumption due to DHW production. Moreover, the primary energy consumption due to auxiliary equipments is lower for the simple exhaust ventilation system. In fact, the specific fan consumption is smaller for this case.

The major drawback for the simple exhaust ventilation is the high primary energy consumption due to space heating, compared to balanced ventilation systems. Indeed, the heating capacity of the exhaust air heat pump is limited and is not sufficient to satisfy the heating demand of the building. As a result, the auxiliary electrical heater is activated and the primary energy consumption increases. It would be interesting to use another auxiliary heating system (heat pump, gas boiler) but the investment cost would increase too much.

Compared to balanced ventilation with gas condensing boiler, the simple exhaust ventilation with EAHP has almost the same efficiency in terms of primary energy consumption. Moreover, if the primary energy factor (PEF) is lower than 2.26, the simple exhaust ventilation with EAHP is more efficient than the balanced ventilation with condensing gas boiler. Assuming that the PEF will decrease in the future (with the use of renewable energy sources), the simple exhaust ventilation system will become more interesting.

Finally, compared to balanced ventilation with outside air heat pump, the simple exhaust ventilation with EAHP is less effective (15 % of overconsumption). In fact, the energy consumption due to space heating is too high and is not counterbalance by the energy saving from domestic hot water production and auxiliary equipments. The system could be more effective in the case of a warmer climate corresponding to a lower building heating demand.

7 CONCLUSIONS

The present paper focuses on the energy analysis of a simple exhaust ventilation system coupled to an exhaust air heat pump. The system is compared to the traditional balanced ventilation system with heat recovery in terms of primary energy consumption.

In order to determine the annual performance of the system, a numerical model of the exhaust air heat pump based on experimental data is presented. Despite its simplicity, the model is able to predict the system performance with an error lower than 5 %.

The annual simulations are based on a case study which is a typical retrofitted flat representative of the Belgian building stock. In terms of primary energy consumption, the system is as effective as a balanced ventilation system coupled to a gas condensing boiler for DHW production and space heating. However, compared to a balanced ventilation system coupled to an outside air heat pump, the system has a primary energy consumption 15 % higher.

8 ACKNOWLEDGEMENTS

The financial support of the Walloon Region of Belgium to this project is gratefully acknowledged.

9 REFERENCES

Bolher A., Casari R., Fleury E., Marchio D. and Millet J. 1999. *Méthode de calcul des consommations d'énergie des bâtiments climatisés "consoclim"*. Ecole des Mines (Paris).

Berg, J.M., Ruud, H.S, Lindberg, U., Stenlund, M. and Axell, M. 2010. *Exhaust Air Heat Pumps—Results from a Field Study in Sweden*.

Cuevas C., Lebrun J., Lemort V., Winandy E. 2010. *Characterization of a scroll compressor under extended operating conditions*. Applied Thermal Engineering, 30, pp 605–615.

El Fouih, Y., Stabat, P., Rivière, P., Hoang, P., Archambault, V. 2012) *Adequacy of air-to-air heat recovery ventilation system applied in low energy buildings*. Energy and Buildings, 54, pp. 29-39.

European Parliament, Council of the European Union (2012). *Directive 2012/27/EU on Energy Efficiency, Amending Directives 2009/125/EC and 2010/30/EU and Repealing Directives 2004/8/EC and 2006/32/EC*.

<http://eur-lex.europa.eu/LexUriServ/LexUriServ.do?uri=OJ:L:2012:315:0001:0056:EN:PDF>

Fehrm M., Reiners W., Ungemach M. 2002. *Exhaust air heat recovery in buildings*. International Journal of Refrigeration 25, pp 439–449.

Fracastoro.V, Serraino.M. 2010. *Energy analyses of buildings equipped with exhaust air heat pumps (EAHP)*. Energy and Buildings, 42 (8), pp 1283–1289.

Gendebien S., Georges E., bertagnolio S., Lemort V. 2014. *Methodology to characterize a residential building stock using a bottom-up approach: a case study applied to Belgium*. International Journal of Sustainable Energy Planning and Management, 04, pp 71–88.

Knight I. 2007. *European and Canadian non-HVAC electric and DHW load profiles for use in simulating the performance of residential cogeneration systems*. Annex 42 of the International Energy Agency.

Laverge, J., Janssens, A. 2012. *Heat recovery ventilation operation traded off against natural and simple exhaust ventilation in Europe by primary energy factor, carbon dioxide emission, household consumer price and exergy*. Energy and Buildings 50, pp 315–323.

Laverge, J. 2013. *Optimization of design flow rates and component sizing for residential ventilation*. Building and Environment, 65, pp 81–89.

Masy G. 2008. *Definition and validation of a simplified multi-zone dynamic building model connected to heating system and HVAC unit*. Ph.D. thesis, University of Liege.

Mikola A., Kõiv T-A. 2014. *The Efficiency Analysis of the Exhaust Air Heat Pump System*.

Orme M. 2001. *Estimates of the energy impact of ventilation and financial expenditures*. Energy and Buildings, 33 (3), pp. 199–205

Ouadha A., En-nacer M., Imine I. 2008. *Thermodynamic modelling of a water-to-water heat pump using propane as refrigerant*. International Journal of Exergy, 5, No. 4.

Roulet C.A., Heidt F.D., Foradini F., Pibiri M.C. 2001. *Real heat recovery with air handling units*. Energy and Buildings, 33, pp. 495–502.

Wenhua L. 2013. *Simplified steady-state modeling for variable speed compressor*. Applied Thermal Engineering, 50, pp 318-326.