

VENTILATION AND COOLING

18th ANNUAL AIVC CONFERENCE
ATHENS, GREECE, 23-26 SEPTEMBER, 1997

(Title) Ventilation efficiency measurements in real time using the method of
homogeneous tracer emission

(in mechanical ventilated
buildings)

constant injection
i.e. constant
concentration!

(Author)

M R Bassett¹

nieuwe methode
wordt o.a. vergeleken met
de 'pulse method'

(Affiliation) 1 Building Research Association of New Zealand
Private Bag 50908 Porirua City
New Zealand

1. Synopsis

Trouble shooting air distribution problems in mechanically ventilated offices often has to be carried out in limited “after hours” periods. The method of applying a pulse of tracer to the fresh air supply has been found to be too time consuming to map the local mean age of air over complex floor plans. In response an automated gas chromatograph has been developed to make air change efficiency measurements in real time using the method of homogeneous emission. The equipment described here measures SF_6 concentrations at a large number of locations while the tracer is released constantly and as uniformly as possible within the ventilated space. The entire process (including analysing the output from the gas chromatograph) is controlled with a purpose designed computer programme in Visual Basic.

Ventilation efficiency measurements have been completed on twelve separate floors in eight mechanically ventilated buildings. The homogeneous emission method and the pulse method were used and were shown to give the same result in one building and to indicate that the dilution ventilation model most closely describes the ability of common ventilation configurations to deal with pollutants in the breathing zones. Some spatial differences in ventilation performance were evident. It was possible to explain many of these in terms of the distribution of ventilation supply and extract points in relation to internal partitioning.

2. Experimental approach

A schematic diagram of the automated tracer gas dosing and detection system is given in Figure 1. The equipment consists of a gas chromatograph (GC) and electron-capture detector (ECD) with a tracer delivery and sampling system automated to monitor ventilation performance simultaneously at up to 20 locations in a building. In this study, the breathing zones were dosed continuously with SF_6 through as many as 20 equal length small bore tubes supplied with tracer from a single dosing manifold. Tracer released by the flow regulator into the manifold was diluted with room air and pumped to the dosing points. The floor plan was divided into equal area zones coinciding with partitions where possible and a dosing point was located centrally in each zone about 1.5 m above floor level. Air was sampled continuously from a similar number of locations through small bore tubes using a separate pump to that used for dosing. Transport times were kept to less than a minute to ensure that samples selected by the computer controlled scanning valve and analysed by the gas chromatograph were current. The response of the GC to SF_6 was checked every 2-3 days using certified reference gases at 5 ppb and 20 ppb, and the rate of emission of tracer from the dosing regulator was measured by positive displacement several times in each building investigation.

The method used to map the mean age of air in the breathing zones on buildings has been described as the homogeneous emission or constant and uniform emission technique. Sandberg [1] developed a relationship between the mean age of air at a point τ_p and the local concentration of tracer C_p on the basis that tracer was released into the ventilated space of volume V continuously and uniformly at a rate S .

$$\tau_p = C_p/(S/V) \quad 1$$

The mean age of air is often more easily communicated as an effective ventilation rate r_p analogous to the conventional air change rate, as follows:

$$r_p = 1/\tau_p \quad 2$$

The homogeneous emission method has been used mostly with passive sampling and dosing systems to measure long term average ventilation performance in naturally and mechanically ventilated spaces. Recent applications by Stymne [2], Walker et al [3] and Stymne and Boman [4] have used

passive perfluorocarbon dosing techniques with either passive or pumped samples collected on an absorbing material such as charcoal. In this study a gas chromatograph working in real time has been used to record a time history of tracer concentrations at sampling points. This has given a clearer view of the dynamics of tracer concentrations in spaces where ventilation systems run for only part of the day, and ensured that concentrations C_p could be averaged over periods of stability.

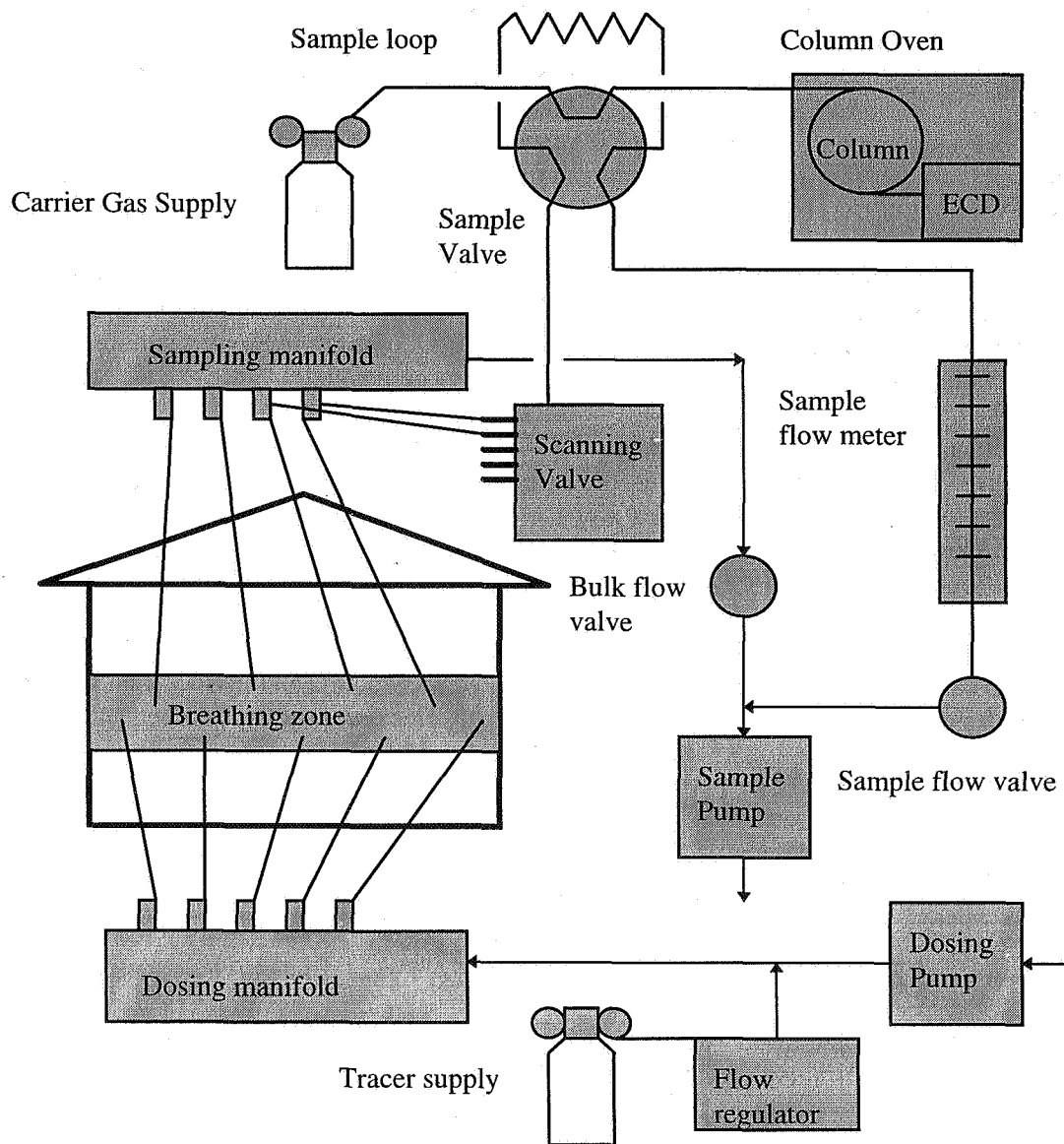

Figure 1: Outline of tracer dosing and sampling equipment for measuring ventilation performance.

3. Building and mechanical system descriptions

The ventilation performance measurements described here were carried out in eight buildings (labelled A to H) located in the central business district of Wellington New Zealand. Buildings A to D are the same as A to D in earlier papers [5,6] and buildings D (level 6) to H provide new data. All were office buildings with varying degrees of internal partitioning ranging from open plan to individual offices.

Buildings A B C and D have previously been described in detail [5,6] and only the key ventilation system characteristics are summarised here. All four buildings were provided with a constant air volume (CAV) air supply of 100% fresh air. In buildings B C and D fresh air was supplied onto the floor from a central duct and ducted from here to the proximity of plenum-mounted fan coil units. The efficiency with which fresh air was supplied to the breathing zones was previously determined by mapping the mean age of air over the floor plan using the pulse method. The important floor plan and air handling system details for buildings A to H are presented in Table 1.

Building E was built in the mid 1980's but the ventilation system was extensively refurbished in 1996. Air was supplied to core zones by a variable air volume (VAV) supply with recirculation, while a (CAV) induction system provided 100% fresh air around the glazed perimeter. In common with buildings F and H, the VAV supply was held at maximum air delivery during the tracer measurements so that effective ventilation rates could be compared with the delivered air supply.

Building F was completed in 1990 to provide high quality office space on 29 levels. It employs a sophisticated building management system to control the ventilation system which delivers CAV air to perimeter zones and VAV air to core areas. In common with buildings E and H, recirculation was at a minimum during the summer months when this tracer study was completed.

Building G was completed in 1996 and level 3 was still in un-tenanted open plan form at the time of these measurements. The ventilation system is the same as building D except that fresh air was discharged into the plenum at only four points along one side of the building. The main point of interest in this building was the uniformity with which the plenum mounted fan coil units distributed fresh air over the floor plan.

Building H was completed in the 1970's and only minor changes to the location and type of ceiling diffusers had been carried out since then. VAV air was supplied at 29 points on the floor plan with the highest density of supply points close to the perimeter. The 1st floor was mostly in open plan form during tracer measurements.

Building descriptions and air handling system capacities						
Building	Level	Floor area m ²	Volume m ³	Ventilation system type	Air supply rate m ³ /h maximum	Exhaust rate m ³ /h
A	3	1,526	4,731	CAV no recirculation	n/d	n/d
A	2	521	2,553	CAV no recirculation	1,826	3,219
B	2	454	1,438	CAV local recirculation	1,750	n/d
B	3	469	1,486	CAV local recirculation	1,573	n/d
C	5	1,476	4,723	CAV local recirculation	3,563	2,600
C	6	1,476	4,723	CAV local recirculation	4,183	2,540
D	7	499	1,536	CAV local recirculation	1,092	Nil
D	6	544	1,671	CAV local recirculation	1,730	Nil
E	6	532	1,430	VAV core CAV perimeter	4,745	n/d
F	27	864	2,324	VAV core CAV perimeter	4,778	n/d
G	4	368	1,114	CAV local recirculation	1,012	n/d
H	1	450	1,248	VAV non local recirculation	8,802	n/d

Table 1: Building descriptions and air handling system capacities (n/d = not determined).

4. Air distribution efficiency

Effective ventilation rates have been measured in all 8 buildings. In buildings A to D (level 7) the pulse method was employed over several weeks to map out the mean age of air on the floor plan. In Buildings D (level 6) to H, the method of homogeneous emission was used, taking three days to accumulate data for at least 30 sample locations on the floor plan. Examples of results for a day are given in Figure 2 for building F and in Figure 3 for building G. Here the ventilation performance is expressed as an effective ventilation rate in air changes per hour (ac/h) according to Equation 2. Figures 2 and 3 have been simplified to show data from only four sampling locations, together with a central fine line representing the mean of 10 sampling locations.

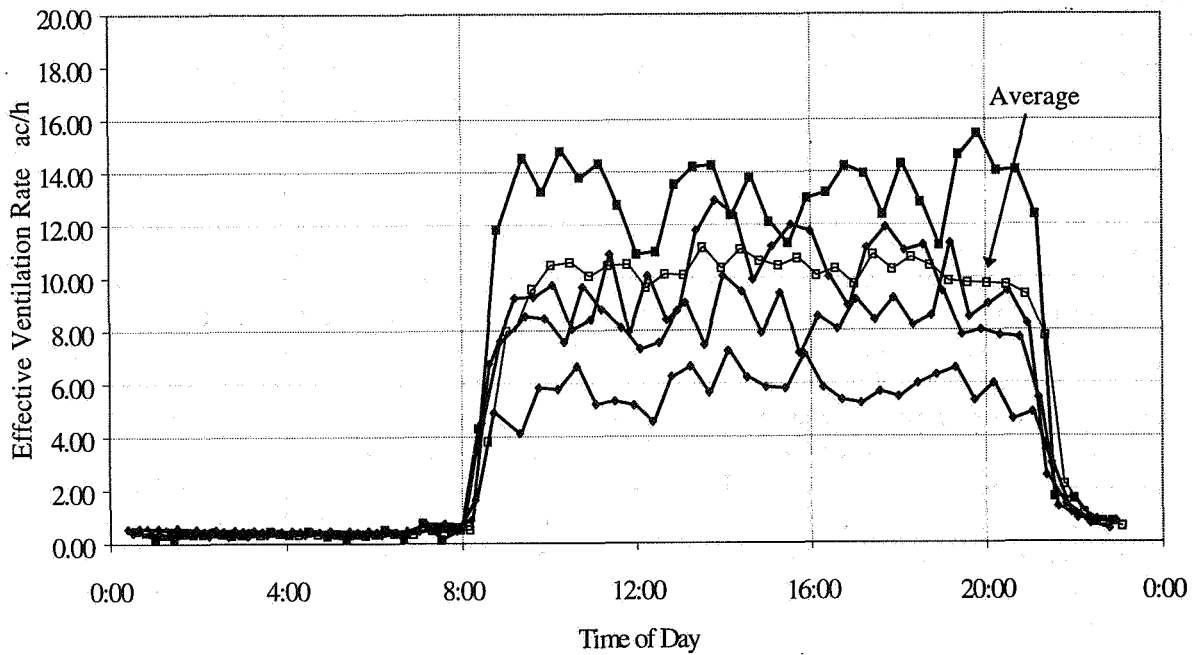

Figure 2: Effective ventilation rates in the breathing zones of building F.

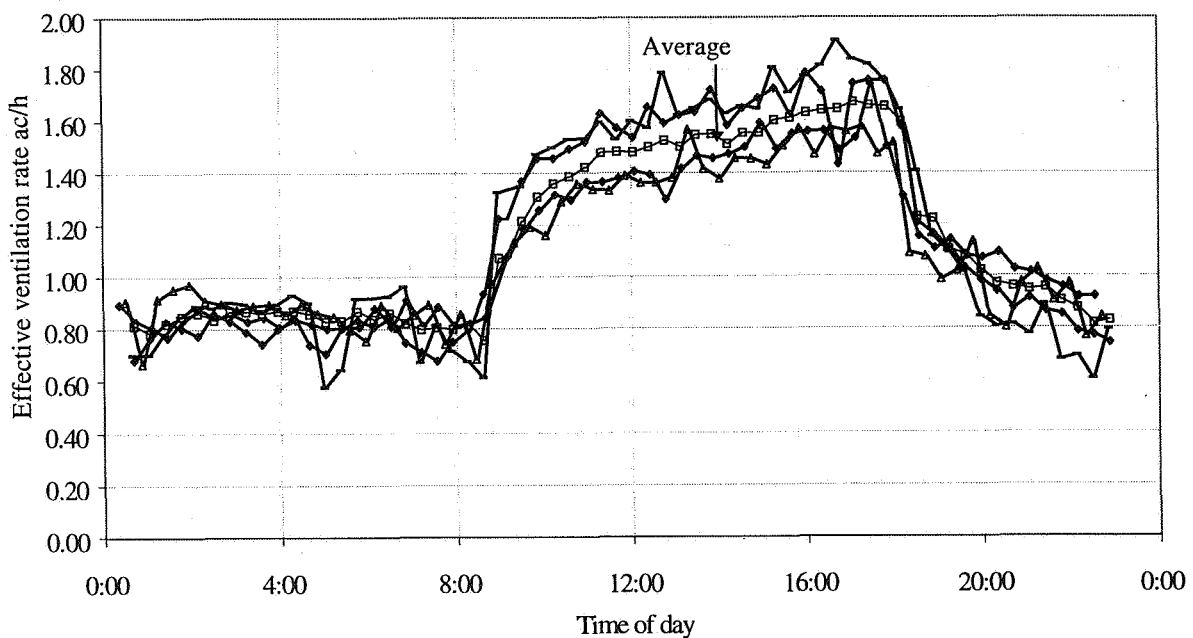

Figure 3: Effective ventilation rates in the breathing zones of building G.

Figures 2 and 3 clearly show how the tracer concentration responded to step changes caused by the ventilation system turning on and off. In building G the nominal time constant of the fresh air supply rate was about 0.6 h and Figure 3 shows that it took several time constants for tracer concentrations to approach steady state. In building F (and in buildings E and H) the time constant was much shorter because the VAV boxes were artificially set to maximum air flow to allow measured air deliveries to be compared with effective ventilation rates. Recirculation was at a minimum in the summer period to provide cooling in all buildings and as a consequence little tracer was detected returning to the floor. In winter with high recirculation fractions this would be reflected as different absolute and relative air change effectiveness results.

With the mechanical ventilation off at night, infiltration rates on floors of buildings E to H were measured and recorded as average mean age of air (infiltration) results in Table 2. In building F the infiltration rates were only weakly dependent on wind speeds, indicating that the measured infiltration was mostly a stack driven vertical air flow through the building. Infiltration and its interaction with mechanical ventilation systems is still relatively poorly understood in office buildings in New Zealand.

The effective ventilation rate was measured at 30 to 50 locations in the breathing zone of each building and the data presented as approximate contours on a floor plan. On the 27th floor of building H there were 61 CAV and 90 VAV terminals so that it was possible to plot both the effective ventilation rate in the breathing zone (Figure 4) and the measured fresh air delivery (Figure 5). The effective ventilation rates in the breathing zone form a similar pattern to the fresh air delivered at ceiling level with highest values around the perimeter. Overall, the effective ventilation rates tend to be higher than would be expected from the dilution ventilation model, especially in the core areas close to the exhaust points at either end of the stair shaft. This indicates that bulk air flows from the perimeter effectively sweep tracer from the core breathing zones. In building G there were grounds for expecting higher effective ventilation rates near fresh air delivery points but in fact air was recirculated sufficiently by the plenum mounted air handlers to eliminate this expected distortion. Figure 6 shows the effective ventilation rates for building G.

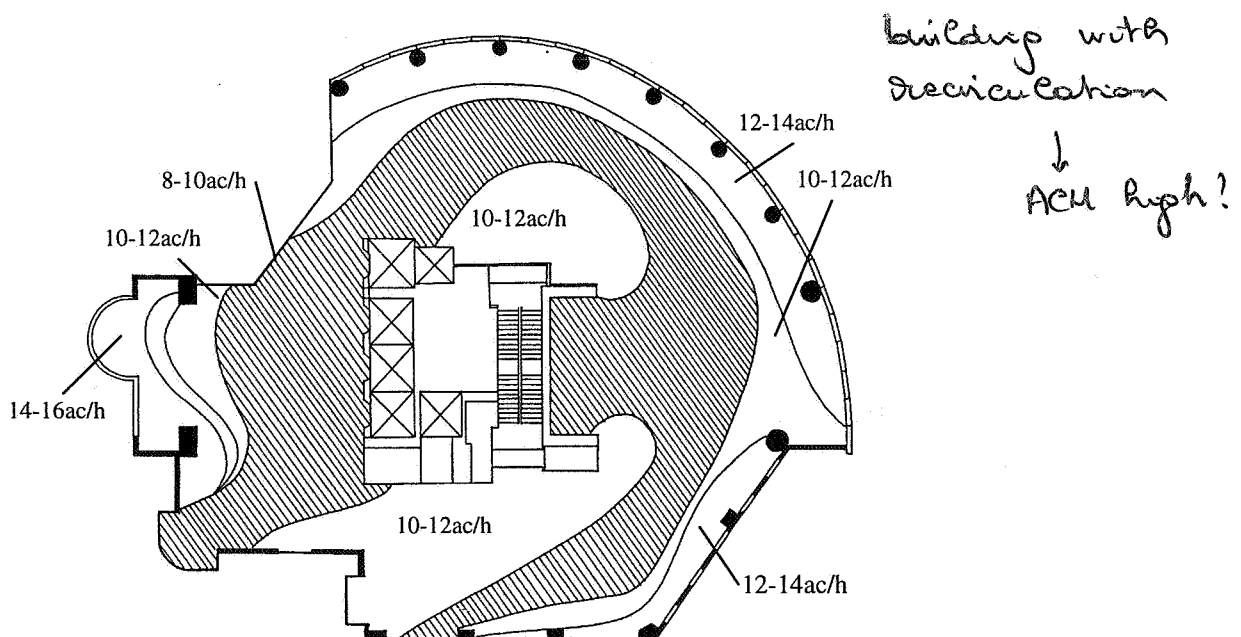

Figure 4: Approximate contours of effective ventilation rate in the breathing zones of building F.

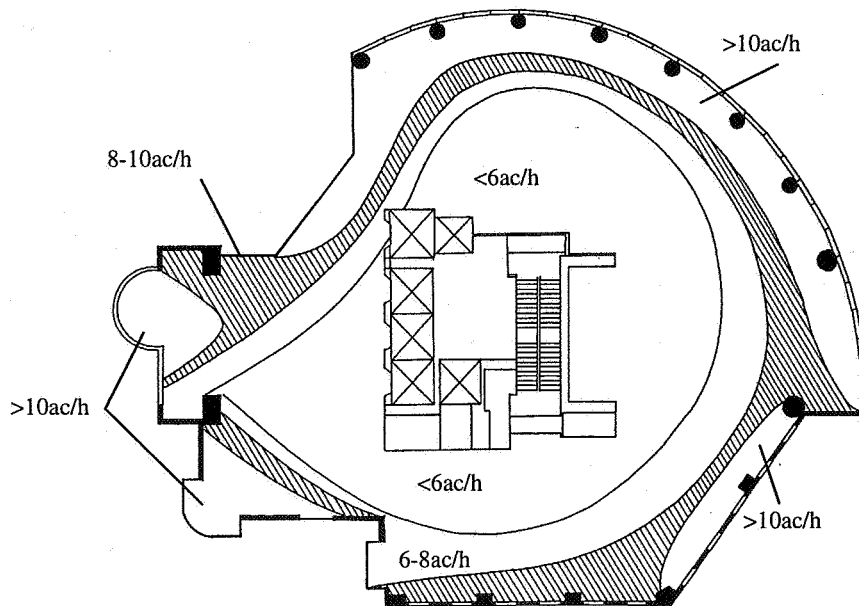

Figure 5: Approximate contours of air flow discharged through the ceiling in building F.

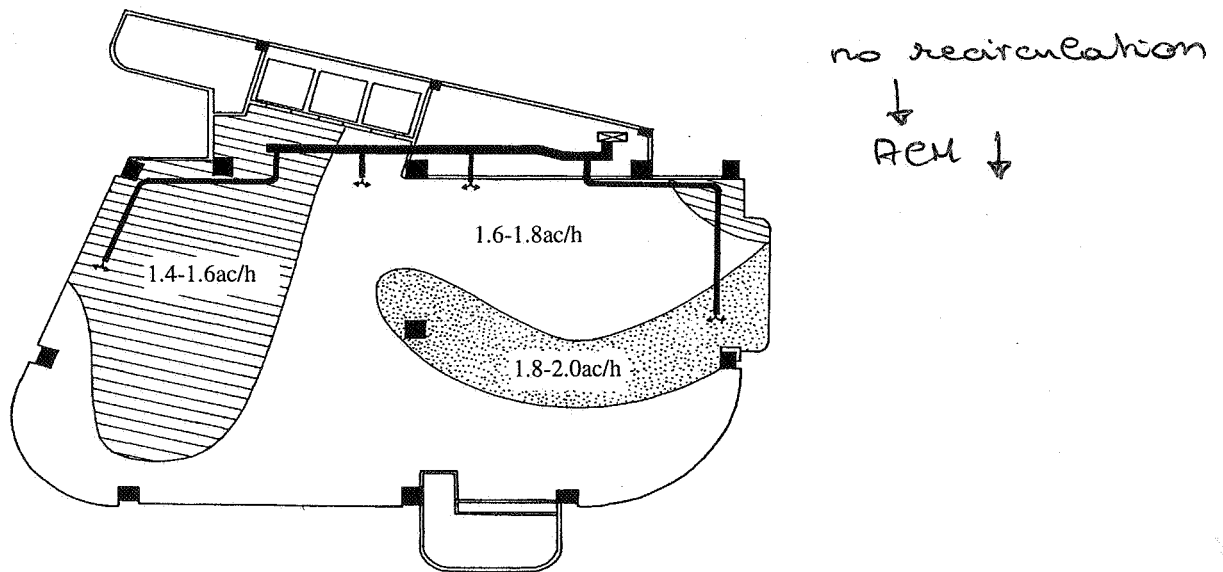

Figure 6: Approximate contours of effective ventilation rate in the breathing zones of building G.

The mean age of air in the breathing zone of each building floor and the air change efficiency have been calculated and recorded in Table 2. These have been calculated from the nominal time constant for the space and the breathing zone averaged mean age of air using the relationships presented by Sutcliffe [7]. In all cases the nominal time constants indicate that air flows delivered to the floor exceeded the requirements in force when the buildings were constructed.

Measured ventilation characteristics in 8 New Zealand office buildings						
Building	Level	Tracer method	Nominal time constant (h)	Mean age of air (infiltration) h	Mean age of air (ventilation) h	Air change efficiency %
A	3	Pulse	0.79	n/d	0.75	53%
A	2	Pulse	-	n/d	0.60	-
B	2	Pulse	0.82	n/d	0.76	54%
B	3	Pulse	0.95	n/d	0.64	74%
C	5	Pulse	1.33	n/d	1.65	40%
C	6	Pulse	1.13	n/d	1.31	43%
D	7	Pulse	1.40	n/d	1.41	50%
D	6	Constant	1.03	n/d	1.03	50%
D	6	Pulse	1.03	n/d	1.02	50%
E	6	Constant	0.28	3.8	0.24	59%
F	27	Constant	0.13	2.7	0.10	62%
G	4	Constant	0.59	1.3	0.60	49%
H	1	Constant	0.12	1.0	0.098	63%

Table 2: Measured ventilation characteristics in 8 New Zealand office buildings.

Where it was possible to measure the nominal time constant, the air change efficiency for the breathing zones was between 40% and 75%. There was no strong link between these results and the type of ventilation system although there is a suggestion that buildings E, F and H with non local mixing and bulk air flows from perimeter to core areas may be more effective at dealing with pollutants in the breathing zone.

Overall, the study has shown that common ventilation configurations in New Zealand office buildings can be regarded as providing dilution ventilation in the breathing zones. The trend in ventilation standards eg. the draft ASHRAE 62 Standard "Ventilation for Indoor Air Quality" [8] is to include the ventilation effectiveness parameter in design calculations for fresh air supply rates. The measurements available from this study will provide supporting information and experience when New Zealand ventilation standards begin to require a consideration of ventilation effectiveness. Other workers, e.g. Fisk and Faulkner [9], have measured ventilation effectiveness parameters in mechanically ventilated buildings and developed a picture of the effectiveness of systems in a range of buildings. In their data, similar conclusions are reached concerning the description of mechanical ventilation in office buildings as primarily dilution ventilation.

5. Sensitivity to dosing strategy

The method of homogeneous emission rests on the assumption that tracer gas can be administered constantly and uniformly through the entire ventilated space. While it is relatively easy to deliver tracer at a constant rate, any realistic number of dosing points will fall short of the infinite number required for uniform emission. The systematic error associated with finite dosing will depend on detailed air flow patterns in relation to dosing and sampling points and this will vary from one building to the next. In this study an indication of the sensitivity to dosing arrangement has been determined by repeatedly measuring the effective ventilation rate at 10 or more fixed points in buildings D to H, while moving the dosing points each day to different sites within the equal volume zones. The pooled standard deviation of the repeated effective ventilation rate measurements in five buildings has been determined as 17%. This is comparable to the systematic error [6] of 20%

associated with pulse method measurements but rather more than a 5% reproducibility error determined for homogeneous emission results by repeating effective ventilation rate measurements in building D. This data was collected with unchanging dosing and sampling sites. An overall uncertainty of 20% has been allocated to the effective ventilation rates measured in buildings D to H.

6. Conclusions

An automated gas chromatograph has been developed to measure the effectiveness of mechanical ventilation systems in real time. The method of homogeneous tracer emission has been used to explore ventilation performance in 5 buildings at the same time as developing an understanding of the limitations of the method and its sensitivity to different dosing strategies. The following conclusions are drawn from the study:

- Equipment for applying the method of homogeneous emission to mapping the efficiency of mechanical ventilation has been developed and trialed in 5 building floors. The method was shown to give the same mean age of air on one floor as that measured by the pulse method. The main advantage of the homogeneous emission method was that results were collected over three days in comparison with more than a month required for the pulse method.
- Sensitivity to the placement of dosing points was explored in five buildings. Between 10 and 20 dosing points releasing a constant flow of diluted tracer were located centrally in equal volume zones. Altering the dosing strategy by moving dosing points around in the equal volume zones influenced the effective ventilation rates measured at fixed locations by 17% (pooled standard deviation from 5 buildings).
- The air change efficiency in the breathing zones of 12 floors in 8 New Zealand office buildings has ranged from 48% to 75% indicating the dilution ventilation model most closely describes the ability of common ventilation configurations to deal with pollutants in the breathing zones.

↳ almost no short circuits

7. Acknowledgments

This work was funded by the Building Research Levy and the Public Good Science Fund of the Foundation for Research, Science and Technology. The assistance of the building owners for access to the buildings, Roger Stanford from BRANZ, Ron Conders from Advanced Building Services Ltd and Mark Sinclair from Colliers Jardine is also gratefully acknowledged.

8. References

- 1 Sandberg, M. 1984. "The multichamber theory reconsidered from a view point of air quality studies". Building and Environment 19, 221.
- 2 Stymne, H. 1995. "Method to determine local mean ages of air exchange efficiency in large buildings and buildings with many rooms". NORDTEST, Final report project No. 1165-94. Helsinki.

- 3 Walker, R. White, M.K. and Bergsøe, N., 1994. "*Application of new strategies for measuring ventilation rates in office buildings as part of an assessment of indoor air quality and energy use.*" Healthy Buildings 94, Proceedings of the 3rd International Conference, Vol. 1, pp319-324, Budapest, Hungary.
- 4 Stymne, H and Boman, C.A., 1996. "*Application of a passive tracer technique in naturally and mechanically ventilated school buildings.*" Proceedings of 17th AIVC Conference, Vol. 1 pp284-291, Gothenburg. Sweden.
- 5 Bassett, M.R. and Isaacs, N., 1994. *Preliminary ventilation effectiveness measurements by a pulse tracer method.* Proceedings of the 15th AIVC Conference, pp644-655, Buxton, England.
- 6 Bassett, M.R. and Isaacs, N., 1994. *Ventilation effectiveness measurements in selected New Zealand office buildings.* Proceedings of the 16th AIVC Conference, pp115-124, Palm Springs, USA.
- 7 Sutcliffe, H. (1990). "*A guide to air change efficiency.*" Air Infiltration and Ventilation Centre, Technical Note 28. Coventry.
- 8 American Society of Heating, Refrigeration and Air-conditioning Engineers, Inc. 1996. "*BSR/ASHRAE Standard 62-1989R.*" Public review draft standard. Atlanta.
- 9 Fisk, W. J. and Faulkner, D., 1992. *Air change effectiveness in office buildings: Measurement techniques and results.* Proceedings of the International Symposium on Room Air Convection and Ventilation Effectiveness, pp282-294. Tokyo.