

REPORT FESA-TS-2070

TECHNIQUES FOR CONTROL OF AIR INFILTRATION IN BUILDINGS

F. B. SHEPHERD
JOHNS-HANVILLE SALES CORPORATION
RESEARCH & DEVELOPMENT CENTER
KEN-CARYL RANCH, DENVER, COLORADO 80217

AUGUST 1970

FINAL REPORT FOR PERIOD 1 SEPTEMBER 1970 - 15 APRIL 1970

APPROVED FOR PUBLIC RELEASE/DISTRIBUTION UNLIMITED

PREPARED FOR:

U.S. ARMY FACILITIES ENGINEERING SUPPORT AGENCY
TECHNOLOGY SUPPORT DIVISION
FORT BELVOIR, VIRGINIA 22060

TECHNICAL NOTE

TECHNIQUES FOR CONTROL OF AIR INFILTRATION IN BUILDINGS

PURPOSE

This Technical Note provides detailed methods for safe retrofitting of residential buildings to reduce air infiltration. A procedure for estimating the payback period for investment in infiltration reduction is included together with a simple test for measuring induced air infiltration.

APPLICABILITY

This Technical Note applies to all Facilities Engineering elements responsible for Design, Operation, and/or Maintenance of Energy Conservation Programs at Army installations.

DISCUSSION

Air infiltration into buildings is a major contributor to heating and cooling energy costs. The sources of air infiltration have been identified and can be treated with moderately and low priced materials applied by unskilled labor to achieve significant reductions in energy cost.

A few typical sources of air infiltration and the materials used to combat the air flow include:

<u>Source</u>	<u>Material</u>
Wall-Floor Joint	Glass Mat/Adhesive
Electric Outlets	Foam Gasket
Window-Exterior Wall Junction	Caulking
Metal Air Distribution Ducts	Tape
Doors	Weatherstripping

A method for measuring induced air infiltration has been used by a number of investigators. This method involves the use of a relatively inexpensive fan-duct assembly inserted in a window or door opening. The fan

REFORT FESA-TS-2070

TECHNIQUES FOR CONTROL OF AIR INFILTRATION IN BUILDINGS

P. B SHEPHERD
JOHNS-MANVILLE SALES CORPORATION
RESEARCH & DEVELOPMENT CENTER
KEN-CARYL RANCH, DENVER, COLORADO 80217

AUGUST 1979

FINAL REPORT FOR PERIOD 1 SEPTEMBER 1978 - 15 APRIL 1979

APPROVED FOR PUBLIC RELEASE/DISTRIBUTION UNLIMITED

PREPARED FOR:

U.S. ARMY FACILITIES ENGINEERING SUPPORT AGENCY
TECHNOLOGY SUPPORT DIVISION
FORT BELVOIR, VIRGINIA 22060



Department of Industry
Technology Reports Centre
Orpington, Kent, BR5 3RF

Telephone: Orpington (0689) 32111
Telex : 896866 MOD PE G

NOTE TO USER

The legibility of paper-copy reproduced from microfiche is governed by the master supplied. Some print in this report may not therefore be clear, but the report is provided in the interest of making available as much information as possible.

Sometimes the text on the microfiche is clearer when read on a viewer. If you would like to have a copy of the microfiche please let us know.

TR501 (Rev 12/80)

REPORT #FSA-TS-2070

TECHNIQUES FOR CONTROL OF AIR
INFILTRATION IN BUILDINGS

FINAL REPORT

REPORT DOCUMENTATION PAGE		READ INSTRUCTIONS REPORT COMPLETING FORM
1. REPORT NUMBER FESA-TS-2070	12. GOVT ACCESSION NO.	3. RECIPIENT'S CATALOG NUMBER
4. TITLE (and Subtitle) Techniques for Control of Air Infiltration in Buildings	7	5. TYPE OF REPORT & PERIOD COVERED Final rept. 1 Sep 78-15 Apr 79
6. AUTHOR(s) Philip B./Shepherd Judith E./Gerharter	15	8. CONTRACT OR GRANT NUMBER(s) DAAK 78-78-D-0002
9. PERFORMING ORGANIZATION NAME AND ADDRESS Johns-Manville Sales Corporation Research & Development Center Ken-Caryl Ranch, Denver, Colorado 80217		10. PROGRAM ELEMENT, PROJECT, TASK AREA & WORK UNIT NUMBERS 0006
11. CONTROLLING OFFICE NAME AND ADDRESS U. S. Army Facilities Engineering Support Agency, Technology Support Division Fort Belvoir, Virginia 22060	14	12. REPORT DATE 30 Apr 79
14. MONITORING AGENCY NAME & ADDRESS (if different from Controlling Office) 12 118		13. NUMBER OF PAGES
		15. SECURITY CLASS. (of this report) Unclassified
		15a. DECLASSIFICATION/DOWNGRADING SCHEDULE
16. DISTRIBUTION STATEMENT (of this Report) Approved for Public Release, Distribution Unlimited		
17. DISTRIBUTION STATEMENT (of the abstract entered in Block 20, if different from Report)		
18. SUPPLEMENTARY NOTES		
19. KEY WORDS (Continue on reverse side if necessary; and identify by block number) Energy, Conservation, Air Infiltration, Retrofit		
20. ABSTRACT (Continue on reverse side if necessary; and identify by block number) Materials and systems for reducing or eliminating air infiltration through almost all identified leakage sources have been found. Most of these materials are inexpensive, effective, and relatively easy to install or apply. These materials are generally designed to seal or close up small cracks or large openings in residential buildings. They encompass a very broad range of different methods such as caulking, adhesive/glass mat,		

No. 20 Continued

weatherstripping, vent dampers, and many more. Those items having suitable effectiveness have been incorporated into a recommended procedure for treating existing and new construction. This procedure relies on the use of a special fan assembly and test procedures for locating air leaks in existing buildings and for measuring induced air infiltration in all buildings. The effectiveness of the different materials and systems is quite variable. Cost effectiveness has not been reliably measured; however, existing evidence strongly points to many air infiltration reduction materials as being highly cost effective with the exception of storm doors and, in some instances, storm windows.

assembly is easily operated by unskilled labor. It permits rapid measurement of air leakage in a house, is essential to assist in locating exact points of air leakage, and is necessary to insure that retrofit procedures do not result in a house being made too tight. A dwelling which is too tight may offer a threat to health and life through the buildup of indoor air pollution and/or the malfunction of fossil fuel combustion furnaces.

Preliminary standards have been suggested for air leakage in houses designed to guard against potential health hazards.

ECONOMICS

Energy savings achievable through infiltration retrofit are significant. A 15 percent reduction in annual heating/cooling costs is conservatively achievable according to a report entitled "Techniques for Control of Air Infiltration in Buildings", provided under Contract DAAK 70-78-D-0002. This report contains a chart for estimating the years of payback period for houses of varying floor areas and annual energy costs. It is important to note that a complete program of infiltration retrofit is necessary to achieve significant savings. Partial or piecemeal approaches to sealing building air leaks may have no impact on energy cost.

The approximate cost for complete infiltration retrofit of residences should be about \$0.50 per square foot for dwellings having between 1200 to 3000 square feet of living area.

GUIDELINES TO IMPLEMENTATION

Induced air infiltration measurement, location of air infiltration sites, and retrofit is a fairly easy process and no special skills or training are required. The Facilities Engineering Support Agency prepared a report entitled "Techniques for Control of Air Infiltration in Buildings" to assist Facilities Engineers in analyzing and implementing air infiltration retrofit. The field application of proven methods to analyze and treat air infiltration are contained in the Appendices of this report as follows:

- Appendix A - Sources of Air Infiltration
- Appendix B - Materials to Reduce Air Infiltration
- Appendix C - Step By Step Retrofit Guide
- Appendix D - Test Methods

SUMMARY

Infiltration of unconditioned air into buildings has been identified as a significant contributor to heating and cooling energy costs. The purpose of this study was to recommend products and techniques for reducing air infiltration in old and new buildings including data on actual cost effectiveness. An additional objective was to summarize the practical means of measuring air infiltration and to identify economical infiltration reduction procedures which could be implemented.

Materials and systems for reducing or eliminating air infiltration through almost all identified leakage sources have been found. Most of these materials are inexpensive, effective, and relatively easy to install or apply. These materials are generally designed to seal or close up small cracks or large openings in residential buildings. They encompass a very broad range of different methods such as caulking, adhesive/glass mat, weatherstripping, vent dampers, and many more. Those items having suitable effectiveness have been incorporated into a recommended procedure for treating existing and new construction. This procedure relies on the use of a special fan assembly and test procedures for locating air leaks in existing buildings and for measuring induced air infiltration in all buildings. The effectiveness of the different materials and systems is quite variable. Cost effectiveness has not been reliably measured; however, existing evidence strongly points to many air infiltration reduction materials as being highly cost effective with the exception of storm doors and, in some instances, storm windows.

The broad range of estimates place the cost of heating or cooling infiltration air at between 17 and 67 percent of a dwellings annual energy cost. Recent unpublished experiments involving 29 electrically heated homes showed that reductions in induced infiltration of from 15 to 73 percent were achieved with an average 41 percent reduction. The improvements were made using, for the greater part, inexpensive readily available adhesive and glass mat, caulks, tapes, and weatherstrips. Therefore, it was concluded that many of the infiltration reducing steps will be cost effective despite the fact that no experience data are available to quantify the conclusion or the savings to be

achieved. It could be concluded that a 15 percent reduction in energy cost might be achieved conservatively on the basis of data quoted above. An example would be a 1500 square foot house in Denver having an \$800 per year heating/cooling bill. A 41 percent infiltration reduction has been achieved resulting in a theoretical 15 percent or \$120 per year savings. The cost to treat this house for 41 percent infiltration reduction would be in the neighborhood of \$745; thus, the payback period would be just over six years assuming no inflation in energy cost. While the above is theoretical, it also seems reasonable and should be confirmed in tests on 29 houses scheduled for final evaluation after the 1979-1980 heating season.

The cost of reducing infiltration in existing houses will not be great in many cases as illustrated above. The ideal way to combat infiltration is through good design and construction. The unpublished study of the nearly new houses in the Denver area showed that infiltration susceptibility induced by fan depressurization ranged from 500 to 1800 cfm. Complete infiltration retrofit reduced this range to 300 to 1300 cfm. Some modest revisions to good construction practices and energy efficient materials could have eliminated the need for retrofit. A comparison of two new houses in Ohio having only one difference (type of sheathing) in construction showed a very large difference in infiltration and large differences in response to wind load effect on infiltration.¹

The need to minimize infiltration through good tight construction was long ago recognized in publications of the National Warm Air Heating and Air Conditioning Association.² They illustrated three typical types of framing systems

- braced frame
- platform frame
- balloon frame

and made carpentry recommendations to minimize air infiltration and air flow within the frame. There are many good sources of recommendations on materials and methods for tight construction.

PREFACE

The assistance of Dr. P. L. Earle, Consultant, in obtaining information relating to energy conservation programs in Florida and Minnesota was helpful in the preparation of this report. The contributions by Dr. Earle in the areas of caulking and construction methods are also acknowledged.

Special note is given to the Electric Power Research Institute for their permission to use unpublished data and findings from a continuing study of air infiltration effects in 59 electrically heated houses located in and near Denver, Colorado.

The following persons contributed valuable information through personal interviews.

Mr. David Grimsrud, Lawrence Berkeley Laboratory
Mr. Craig Hollowell, Lawrence Berkeley Laboratory
Mr. Urban Gibson, Texas Power & Light Company
Mr. Don Heine, Texas Power & Light Company
Mr. Roger Thornhill, Centennial Builders, Dallas, Texas
Mr. C. M. Hunt, National Bureau of Standards
Mr. Daniel Talbot, NAHB Research Foundation
Mr. David Harrje, Princeton University

TABLE OF CONTENTS

	<u>PAGE</u>
SUMMARY.....	1
PREFACE.....	3
INTRODUCTION.....	5
IDENTIFICATION & TREATMENT OF AIR INFILTRATION	
Sources of Air Infiltration.....	6
Products & Materials to Reduce Air Infiltration.....	10
Methods to Reduce Air Infiltration.....	11
Measurement of Air Infiltration.....	19
Cost Effectiveness of Air Infiltration Reduction....	20
Safety Considerations of Air Infiltration.....	23
LITERATURE SURVEY.....	25
CONCLUSIONS.....	32
RECOMMENDATIONS.....	33
REFERENCES.....	34
BIBLIOGRAPHY.....	41
APPENDICES	
A. Sources of Air Infiltration.....	63
B. Materials for Reducing Air Infiltration.....	68
C. Step By Step Guide to Infiltration Reduction In Existing Dwellings (Retrofit).....	87
D. Test Methods.....	94

INTRODUCTION

Infiltration has long been regarded as a significant factor in determining the heating and cooling energy requirements of buildings. The Florida Project Conserve Team has stated that tight construction is the first prerequisite to an energy efficient home.³ They indicated that tight construction requires proper knowledge, good workmanship, quality components, caulking, and weatherstripping. Sweden has addressed the heating aspect both in their Building Code SBN 75 and in a special publication on airtight construction.⁴ ASHRAE has provided a means for estimating the infiltration contribution to energy requirements based on estimates of cracks around windows and doors.⁵ This method is recognized as an imprecise estimate. It may be tempered by utility companies who multiply the answer by a "geographical-or-experience" factor which is different in various areas of the country. The net result of incorporating infiltration and experience factors into energy equipment sizing procedures seems to be that heating and air conditioning equipment is seldom undersized.

The technical literature on the subject of infiltration is extensive in the area of infiltration measurement by gas diffusion and induced pressure drop. The literature is very limited in the practical area of energy use and savings related to air infiltration and its control. Efforts to correlate air infiltration measurement with energy usage appear to have been frustrating experiences for competent scientists. The lack of quantitative correlation has been properly attributed to a very large and immeasurable variable -- "family living habits" -- combined with very small samples. Studies are now underway in California, Colorado, and other places which may lead to further real measurement of the effect of infiltration on heating and cooling costs such as was disclosed in the Twin Rivers Study by Harrje.⁶

This report consists of Conclusions, Recommendations, Literature Survey, and Identification and Treatment of Air Infiltration. This latter section discusses the following topics:

- *Sources of Air Infiltration
- *Materials to Reduce Air Infiltration
- *Methods to Reduce Air Infiltration

- *Measurement of Air Infiltration
- *Cost Effectiveness of Infiltration Reduction
- *Safety Considerations

The Appendices describe in detail how to treat air infiltration in existing and new construction together with designs for the special fan assembly (Super Sucker) needed to locate leaks and insure a safe and effective treatment of air infiltration.

IDENTIFICATION & TREATMENT OF AIR INFILTRATION

Sources of Air Intiltration

The locations of air entry into residential and light commercial buildings have been identified using a simple evacuation method. The simple fan device used has been called a Super Sucker by the Texas Power & Light Company. One type of fan is shown in Figure 1.

This work has been done by Texas Power & Light for warm climate and by Johns-Manville Sales Corporation for cold climate. The results of the two studies were similar. They showed that nearly all infiltration sites are created during construction either by design, by standard construction techniques, or by poor construction practices. The degree of contribution of the various sources of infiltration found in the Texas study is depicted in Figure 2. The frequency of occurrence of infiltration sources found in the Colorado study is listed in Table 1. A detailed list together with a discussion of how the problem may be created during construction appears in Appendix A.

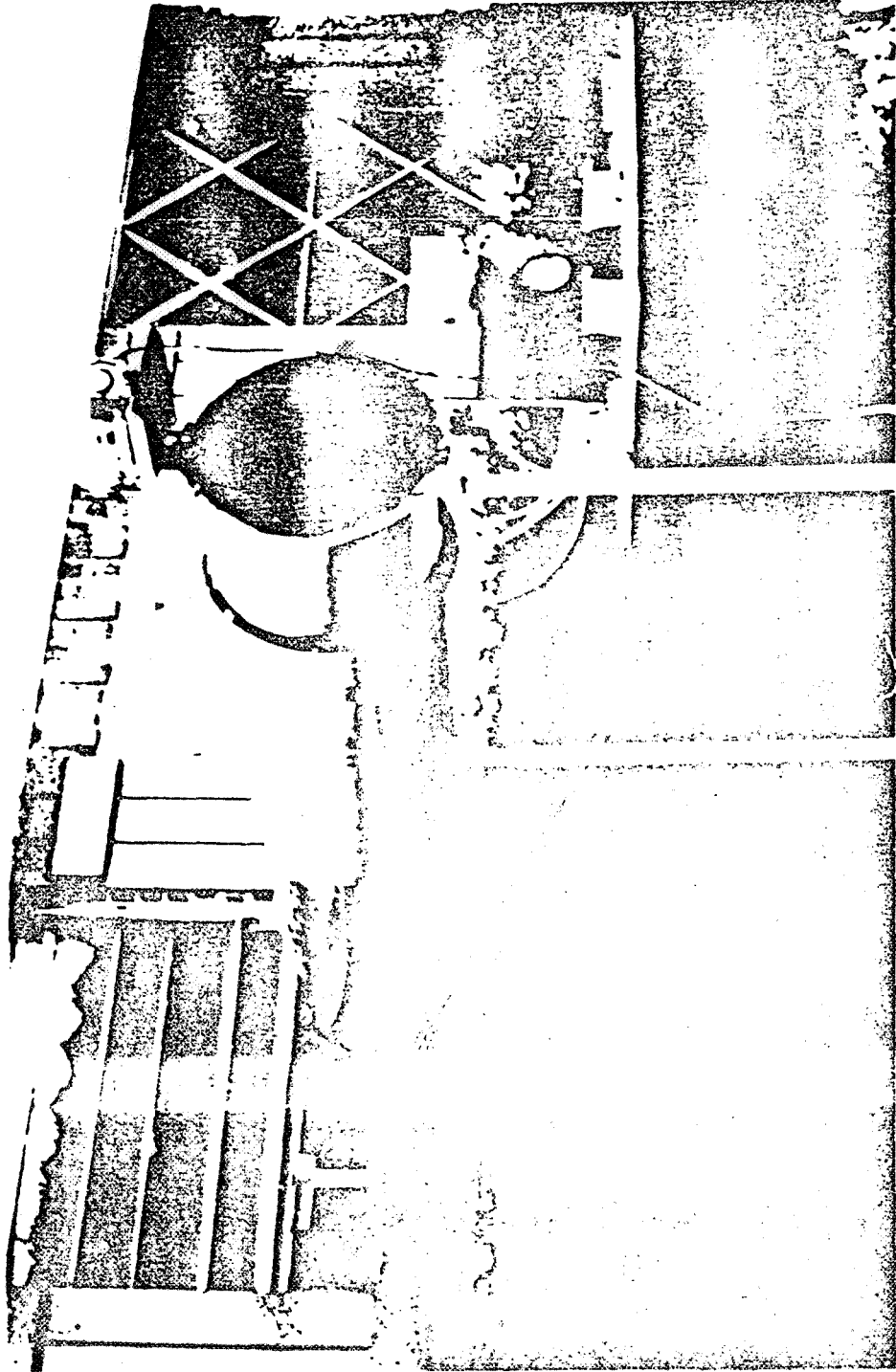

FIGURE 1. SUPEP SUCKER MOUNTED IN WINDOW

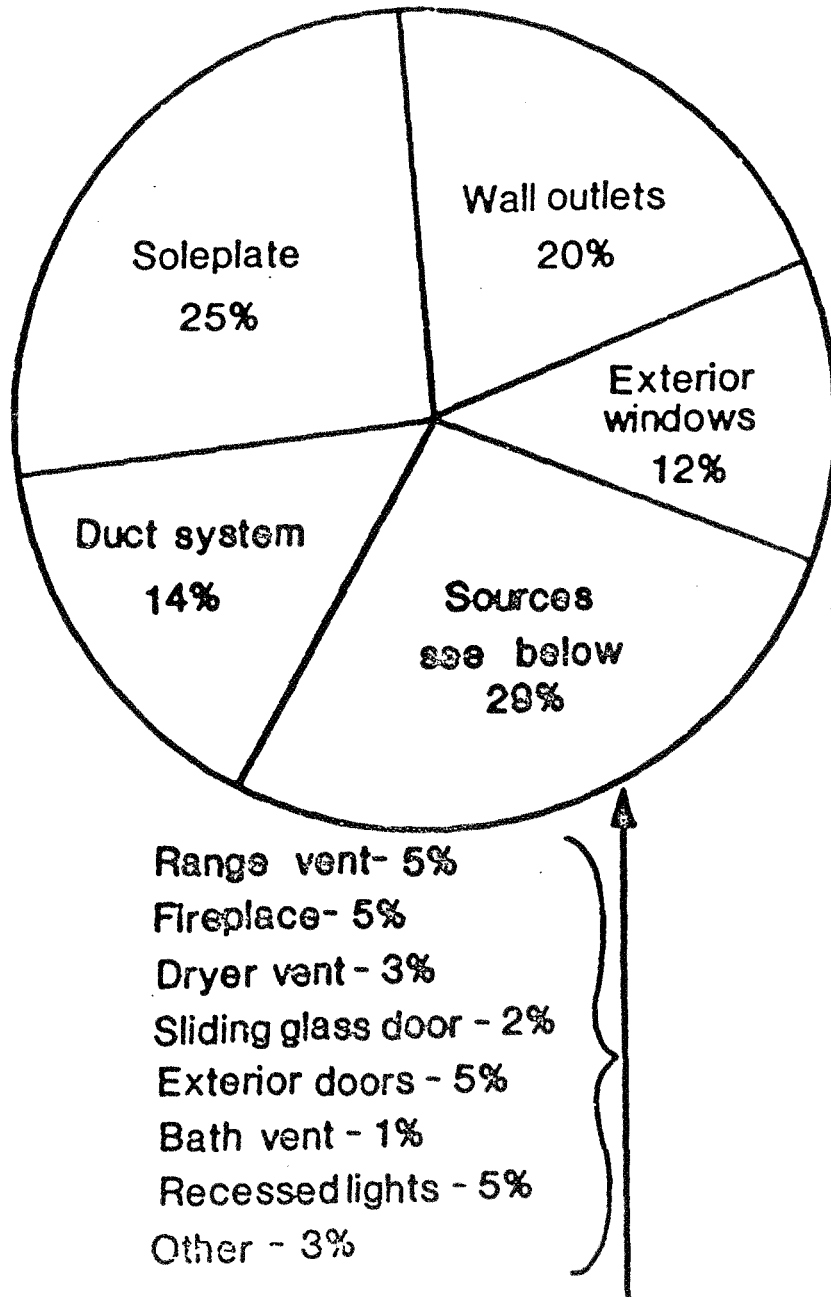

FIGURE 2. SOURCE CONTRIBUTION TO AIR INFILTRATION IN TEXAS STUDY

Table 1. Major Sources of Air Infiltration
In Electrically Heated Homes

<u>Source of Infiltration</u>	<u>Percent of Houses Requiring Retrofit In Colorado Study</u>
Sole or Base Plate	100
Exterior Windows	83
Electrical Fixtures Including Medicine Cabinets	76
Plumbing Fixtures	72
Bath and Kitchen Vents	65
Fireplace	62
Exterior Doors	55
Air Duct System	24
Dryer Vent	21

NOTE: These were electrically heated homes. Furnace and water heater flues have been found to be a major source of infiltration in homes burning fossil fuel. Refer to Appendix A for a complete list, including over 30 additional infiltration sources which have required retrofit in some homes.

Products & Materials to Reduce Air Infiltration

Air infiltration reduction and control involves carefully selecting a suitable product to fulfill one of the following generalized functions in both new construction and retrofit:

- *cover large openings in the building
- *fill and seal fixed cracks and holes
- *seal joints between moving and fixed parts of the building.

The proved procedure for retrofit requires the use of a fan and duct assembly for mounting in a window or door. Simple pressure gauges permit the measurement of induced air infiltration sometimes referred to as the "leakage" of the building. The fan assembly facilitates rapid identification of leaks requiring treatment. It is essential that the leakage be measured to insure that new and retrofit houses are not too tight creating potential health hazards from indoor air pollution and malfunction of combustion furnaces and water heaters. Fan assemblies are usually installed within 15 to 30 minutes and have been easily and reliably operated by unskilled labor. Total setup time in some houses may take slightly longer as it is necessary to safely seal open flues. This is described in detail in Appendix C.

The cost to build a fan assembly duplicating the Johns-Manville device is about \$1300 including an estimated \$600 in contract machinist labor. This might be reduced by about \$300 if a constant speed motor and duct damper were incorporated. The parts required to duplicate the Texas Power & Light Company device were estimated to cost about \$900. No labor estimate was obtained. The assembly details are listed in Appendix D. It is recommended that fan assemblies be built and employed in all retrofit work as well as for testing new houses built to have low air infiltration. It is believed that the modest cost of the fan will be paid back by:

- *labor savings of more rapid retrofit
- *energy savings of more effective retrofit. Partial retrofits have not been effective in reducing the leakage of houses in Denver
- *energy savings of tighter new construction
- *assurance of occupant safety related to air quality and furnace operation

Materials needed for reduction of air infiltration are usually inexpensive and readily available. Those most commonly required include:

- For Retrofit
 - glass mat and adhesive
 - caulking
 - weatherstripping
 - duct tape
 - gypsum wallboard or lumber
 - electric outlet gaskets
- For New Construction
 - sill sealer
 - glass mat and adhesive
 - polyethylene film
 - caulking
 - weatherstripping

There are, of course, many other materials which may be required under certain circumstances and a complete list of materials for retrofit and for new construction appears in Appendix B. This list includes descriptions of the materials together with guidelines for their selection and application.

Methods to Reduce Air Infiltration

Existing Frame Construction Retrofit

The first step in reducing infiltration in existing frame construction is to identify the framing system such as:

- Braced Frame
- Balloon Frame
- Western or Platform Frame

These are illustrated in Figures 3, 4, and 5.

Braced frame construction may be recognized by the following:

- One Piece Corner Posts
- Solid Girders
- Solid Sills
- Heavy Girts to Carry Second Floor Joists

Balloon frame construction studs run from the sill continuously to the rafter supporting plate at the eaves. Balloon and braced frames are to be found in older structures and both feature the sill resting directly on the foundation with wall studs extending upward directly from the sill creating draft channels in the exterior walls. Platform frame construction is the modern method and is identified by

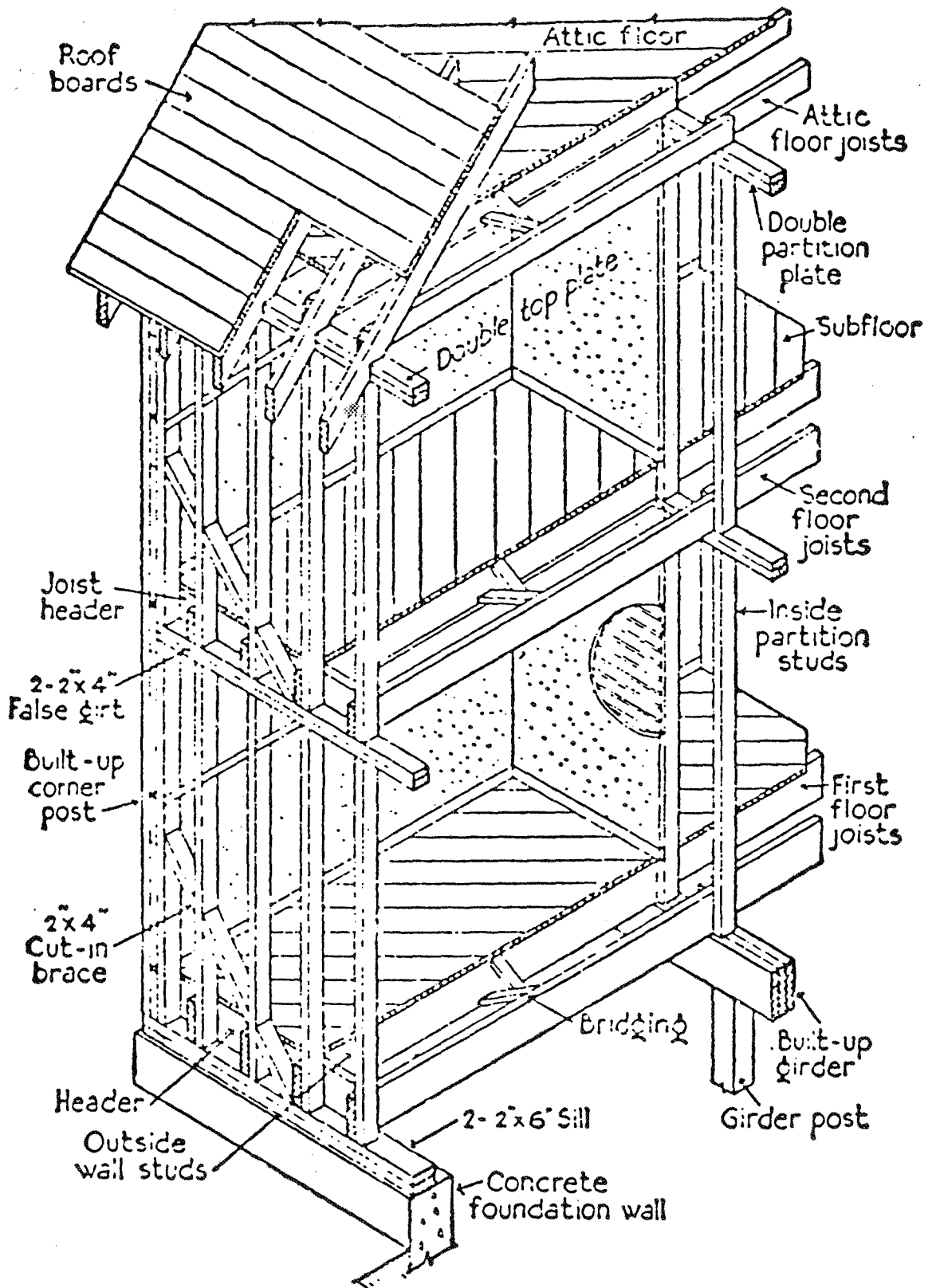

FIGURE 3. BRACED FRAME CONSTRUCTION
12

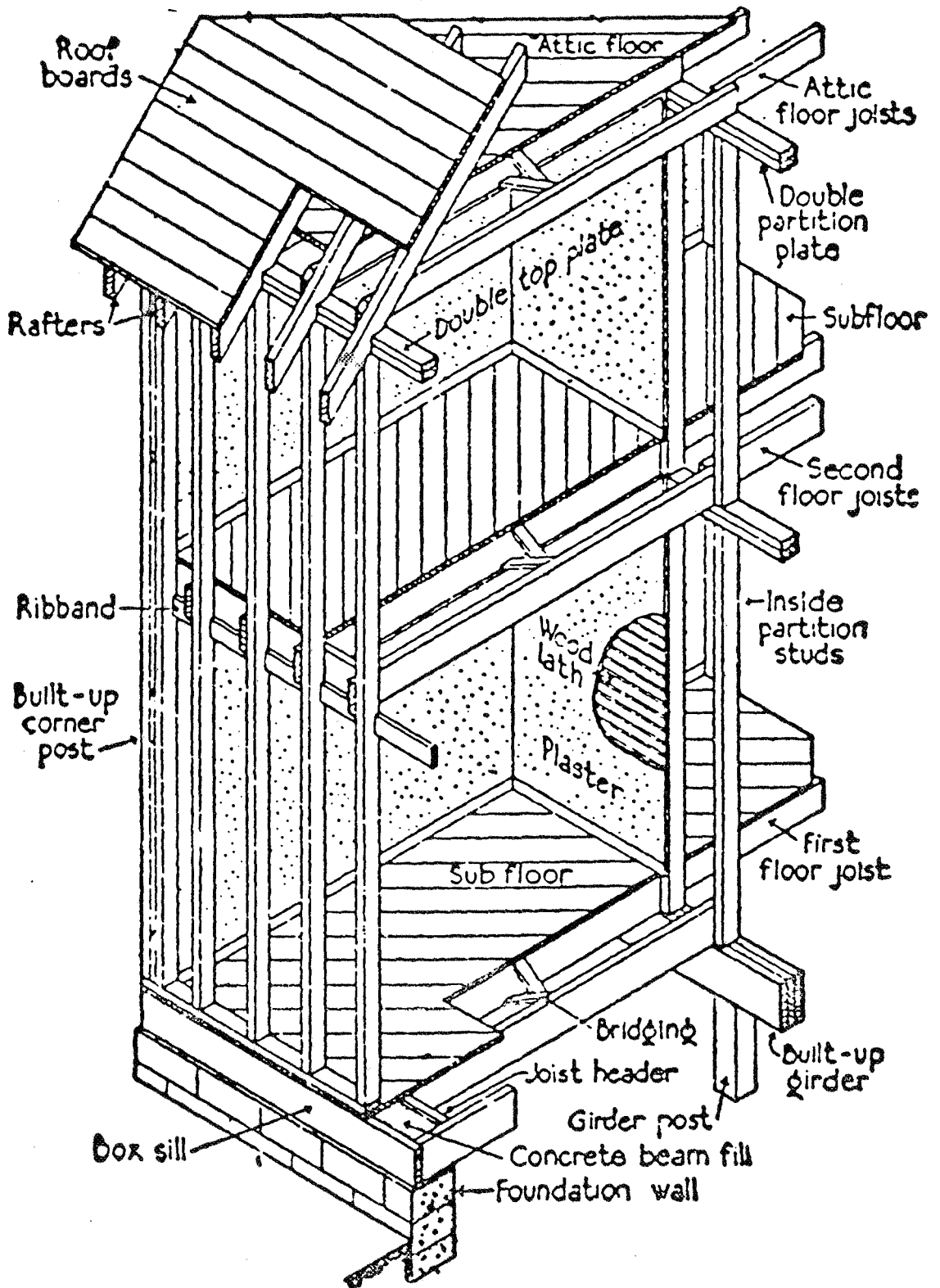

FIGURE 4. BALCONY FRAME CONSTRUCTION

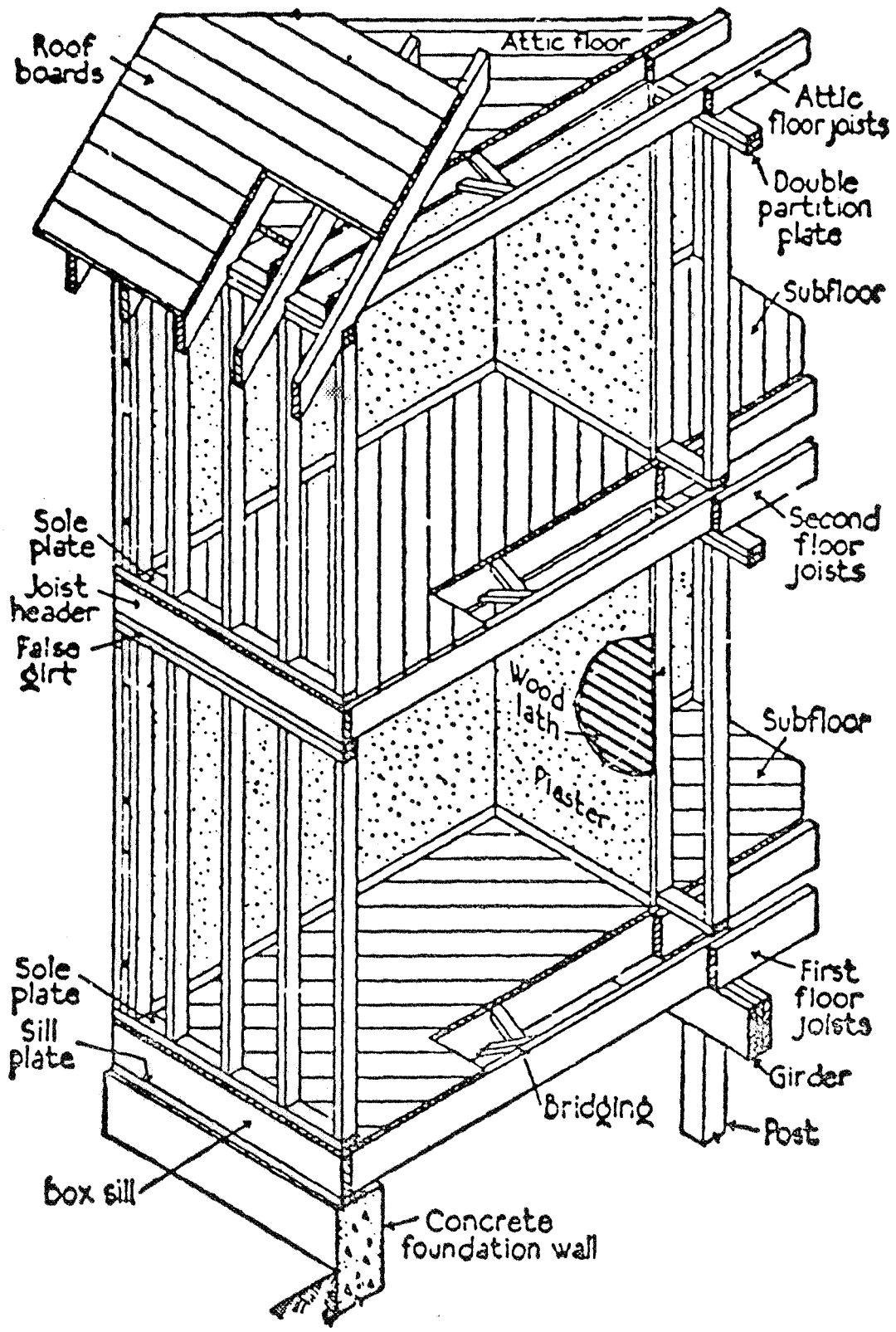

FIGURE 5. PLATFORM FRAME CONSTRUCTION
14

the sole plate for walls fixed to the subfloor resting on floor joists or directly to the concrete slab if the house has no basement or crawl space. No wall studs will be visible upon inspection of the sills. This type of framing is most likely to found since its use began in about the late 1930's.

Balloon and braced frame may present two special problems.

- *Air channel in outside walls
- *Unusual air channels connecting walls and floors plus pipe and duct chases and penetrations in closets and behind false walls.

Appendix C is a step by step guide to infiltration reduction in existing houses. Special steps for treating braced and balloon frame constructions are included.

New Construction

The most economical way to minimize infiltration is through building design, proper component selection, and some modified good construction practices; sometimes applying a few seldom used techniques and methods.

Programs sponsored by several utilities and test houses built by the NAHB Research Foundation have identified economical means for designing and building new houses with excellent resistance to air infiltration.⁸

Recommended Criteria

Important, please note that it is possible to reduce air infiltration to the point where personal health and safety of building occupants is endangered. The fan assembly with measuring device must be used to insure that sufficient fresh air will infiltrate to sustain life and combustion, to guard against spill from furnace flues, and to prevent moisture buildup problems.

The minimum number of calculated building air changes per hour as measured by the special fan assembly at 0.1-inch of water interior vacuum pressure drop across the building envelope should be 1 1/2. Selection of this minimum is based on the lack of data relating to health considerations. See Page 19 for a more detailed discussion. Figure 3 charts velocity pressure readings for 0.1-inch pressure drop for various sized buildings. The chart eliminates the need to calculate air changes and divides the readings into three groups:

(1) building too leaky, (2) building reasonably tight, and

(3) building too tight (danger condition). The "too tight" region is conservative and based solely on judgment expressed in literature and in interviews. Future research may enable further reduction in the extent of leaks in buildings while maintaining safe air quality and preventing moisture problems. Infiltration testing reported in the literature combined with the likelihood for the adoption of residential air quality standards suggests that fan evacuation could provide the basis for a residential performance specification.

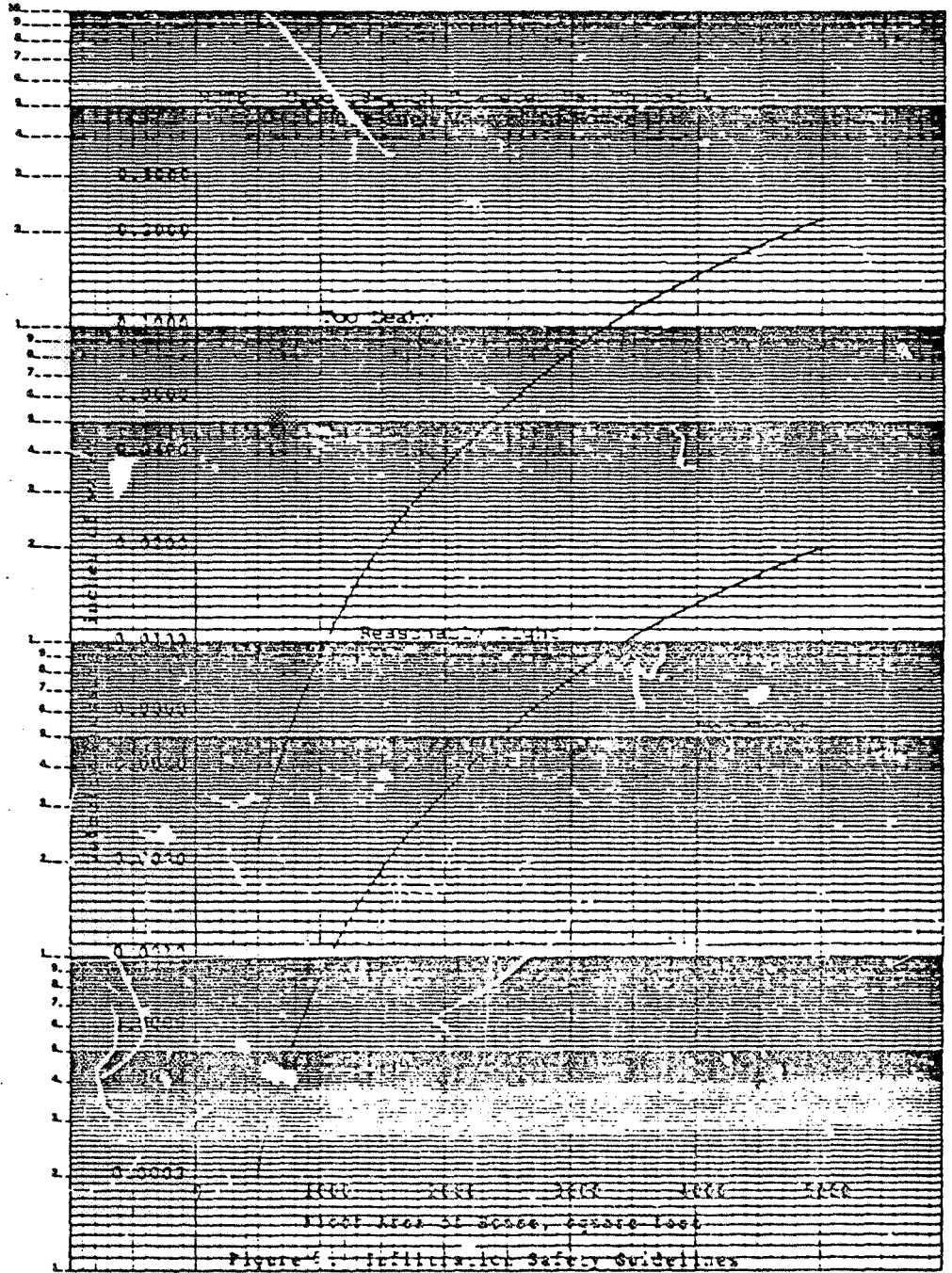

The potential problem of the too-tight house has been addressed in Sweden by the use of forced yet controlled ventilation with heat exchangers which use the conditioned exit air to warm the incoming ventilation air. Little has been published about such heat exchangers and some types are reported to be coming into the American market. The theoretical benefits in permitting reduced infiltration while insuring life safety could make an evaluation of air to air home heat exchangers a worthwhile project. A second approach to removing one of the major hazards in a too-tight house is the use of outside combustion air for furnaces and water heaters. Special units are now sold (for mobile homes), but apparently there are no guidelines nor code requirements for retrofitting existing fossil fuel furnaces and water heaters for outside combustion air. This is a second area concerning both energy savings and personal safety where studies and guidelines are needed.

Consider the apparent contradictions evident in just a few instances.

- An old publication of NWHCA requires that 1/2 of the air to furnaces in a sealed room be drawn from unconditioned space and 1/2 of the air must be ventilation air from conditioned space. This negates one of the perceived benefits of outside air. At least 1 square inch of total duct opening per 1000 BTUH is specified.
- NFPA specifies at least 1 square inch of duct per 5000 BTUH.
- Eastern post-war construction practices sometimes included closed furnace rooms with no combustion air ducts or door louvers.
- U. S. Navy installations of 150 residences at South Weymouth, Massachusetts have furnaces in sealed spaces with combustion and ventilation air provided through louvered doors to the outside. (This seems like an excellent design.)

Development of a system to seal off combustion furnaces and water heaters with safe specifications for outside (unconditioned) combustion air supply would permit a significant reduction in air infiltration and energy savings greater than those achievable by the procedures contained in this report.

Measurement of Air Infiltration

There are four methods for estimating and/or measuring apparent air infiltration of buildings and one standard method of test for door and window leaks. Two of the four methods for determining infiltration are published by ASHRAE.⁹ Both methods are referred to as means of estimation. One is called the Crack Method and the second the Air Change Method. Both are designed to be used as one of several data points for selecting heating, cooling, humidifying, and dehumidifying equipment. They are not, for this reason, pertinent to the objectives of this report.

The remaining two tests for air infiltration in buildings are generally referred to as the Gas Diffusion Method and the Pressurization Method (Super Sucker). There are a number of variations of each one referenced in recent literature.^{10,11} Detailed procedures for each method are included in Appendix D.

The Gas Diffusion Method relies on the dispersion of any easily measured gas such as SF₆ or He throughout the candidate building. Gas concentrations are then measured at frequent intervals together with temperature and wind data. The resulting data are used to calculate a "normalized" air change per hour. The range of data reported in the literature is in the 0.2 to 2.0 broad category of air changes per hour. A variation of the Gas Diffusion Method relies on continually injecting the test gas into the structure to maintain a uniform gas concentration. The rate of gas injection is used to calculate air changes per hour in a manner similar to the gas decay data. Gaseous diffusion tests are rather expensive to run and a complete profile of one home may cost in the neighborhood of \$2,500.

The Pressurization Method may yield valuable data on the extent of leaks in a house for \$40 or so, and this method uses less expensive and less complicated equipment. Pressure testing fans can be easily assembled in a tin shop for less than \$1500; whereas gas diffusion equipment has been custom assembled in laboratories incorporating much more costly and sophisticated scientific devices. The Pressurization Method involves temporarily sealing an uncomplicated fan-in-a-duct assembly to a structure, creating a fixed pressure drop across the structure wall, and measuring the air velocity in the duct. Temperature, humidity, and barometric pressure are also recorded. While the Pressurization Method, which creates a slight vacuum in the house, does not measure true air infiltration, it does provide a widely accepted measure of the extent of leaks in a building and has been compared with air infiltration measured by gaseous diffusion.¹²

This fan method has been used to identify sources of house leaks and to speedup on-site retrofit of major sources of infiltration.^{13,14} It provides the basis for the practical method to reduce infiltration presented in Appendix C. It is expected to provide an analytical tool for quantifying energy savings attributable to infiltration retrofit.¹⁵

ASTM Standard Method of Test E 283 describes a pressure difference procedure for measuring the leakage through doors and windows. This method evaluates each door or window unit in a special chamber. Air infiltration standards have been derived for doors and windows using this test method and these standards have been referenced in Appendix B on materials to reduce air infiltration.

Cost Effectiveness of Air Infiltration Reduction

There are no published studies which report directly the energy savings incurred by air infiltration reduction. There are two major reasons for this situation. First, there is no method for measuring true air infiltration because variations in wind velocity, temperature, humidity, and family living habits create a continual variance in air infiltration. Secondly, most of the published studies on retrofit and new construction have combined air infiltration treatments with changes in insulation making it practically impossible to separate the two effects in a meaningful way. An Ohio State study suggests that treating outside walls of a residence reduced heating energy use by 9 percent.¹⁶ Builders in Texas have claimed a 43 percent reduction in home energy use when homes are designed and built to minimize infiltration.

Air infiltration may account for 17 to 67 percent of the energy usage in a residence with the variation influenced by family habits, degree of insulation, wind, etc. It seems possible that the 17 and 67 percent represent a nearly equal number of BTUs for heating and cooling demand. Air infiltration reductions of 20 to 70 percent have been reported through retrofit and proper design and construction.^{17,18} Air infiltration reductions of 43 percent have been demonstrated to be readily achievable in electrically heated/cooled dwellings.¹⁹ A lesser reduction seems likely in residences with combustion furnace and heater flues having no dampers unless a retrofit for outside combustion air and furnace insulation can be developed. No definitive studies were discovered for this type of building. It may be estimated that a 20 percent air infiltration reduction is achievable for combustion heated residences.

The cost of retrofit and added cost of revised construction have not been determined on a great number of homes. One recent study on 26 electrically heated homes suggests the air infiltration retrofit can be accomplished in about 60 hours for a 2000 square foot living area dwelling.²⁰ The total cost breakdown for a house of this size averaged about:

Labor, \$9.00/hour	-	\$540
Material	-	\$400
Infiltration Test	-	\$ 90 (Two Tests/10 Manhours @ \$9.00)
Total		\$1030

The data, based on limited experience and estimates, are constructed as Figure 4 for estimating the retrofit payback period based on the annual energy bills and inhabited floor area for any dwelling. This figure assumes 10 percent annual inflation in energy cost.

K-E 10 X 10 TO THE CLAYTIMEN 10 X 25 CM
RUBBER & RUBBER CO. MANUFACTURE

46 1513

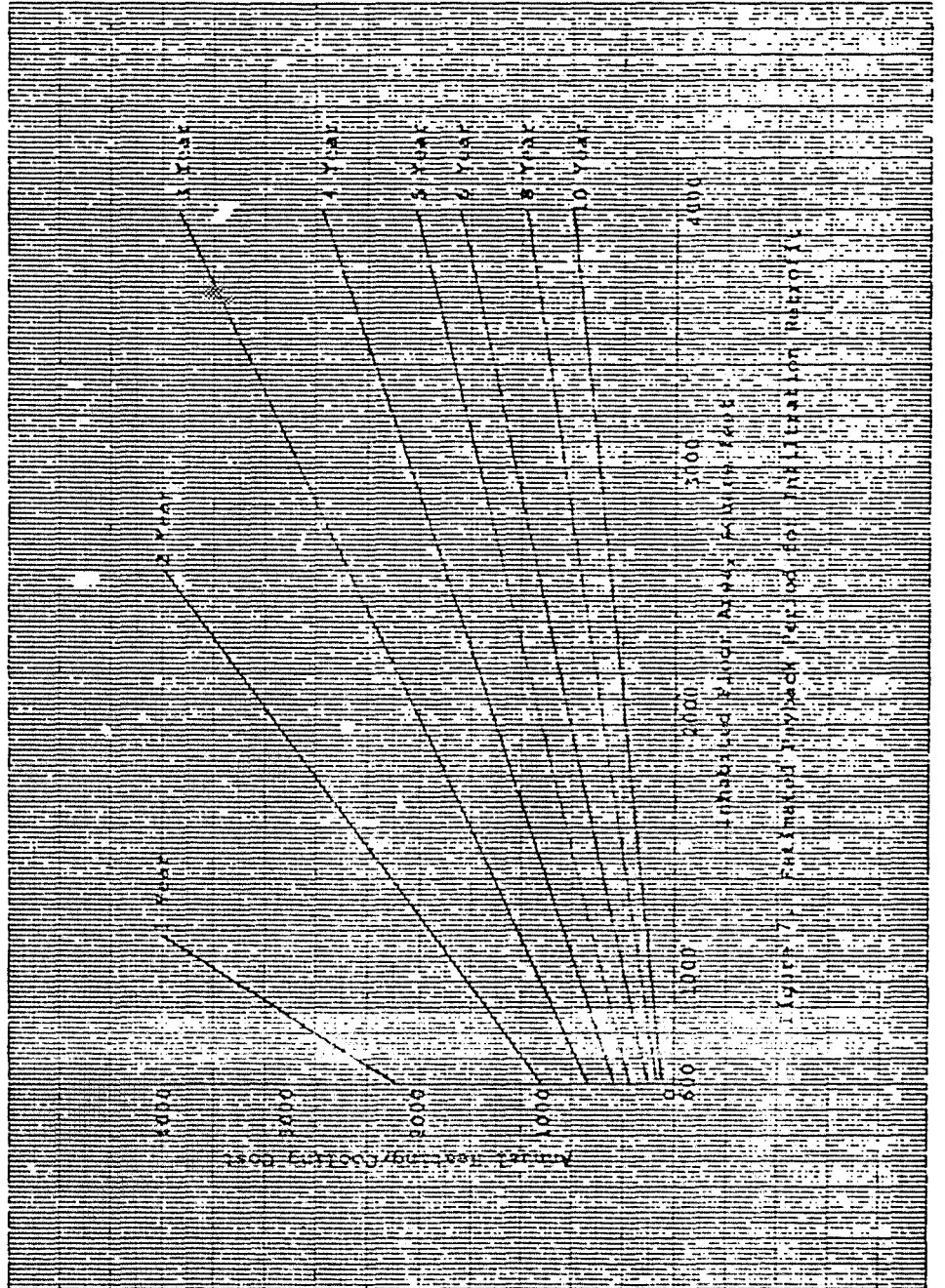

Safety Considerations of Air Infiltration

Occupied dwellings require a minimum number of air changes to comfortably support life. The following requirements must be met.

- There must be a sufficient supply of fresh air to maintain acceptable air quality. Pollution generated in the dwelling must be low to guard against illness (possible suffocation or asphyxiation).
- There must be a sufficient supply of fresh air to remove offensive odors from the dwelling.
- There must be a sufficient supply of oxygen to support combustion of fuels for heating and cooling.
- There must be a sufficient supply of air to insure a positive draft in flues and vents of heating equipment at all times.
- There must be sufficient exchange of air to combat moisture buildup and potential condensation problems. Estimates of moisture generated by family living range from 1 1/2 to 2 1/2 gallons per day by a family of four.

The supply of fresh air can be provided by ventilation. However, controlled ventilation has not been generally considered to be an economical consideration for dwellings in America. Sweden has taken a positive approach by specifying a maximum permissible air infiltration rate for new dwellings and then providing a means for controlled, positive ventilation with heat exchange.²¹ How much air change is required to meet the five safety requirements has not been identified. It is a matter of concern among people who are studying the benefits of reduced air infiltration.²²

The dangers to personal health and life are real. Realization of this is creating badly needed research in this field. ASHRAE has devoted a portion of a chapter to this important topic.²³ ASHRAE has also set forth ventilation requirements based on the occupant density and building use.²⁴ The minimum ventilation for dwellings is 5 cfm per person per 1000 square feet of general living area. The minimum for kitchens and baths is four times that amount. In addition, ASHRAE lists the requirements for minimum air quality for ventilation use.²⁵ External air pollution not meeting the minimum standards for ventilating air must be filtered or otherwise purified.

The hardware to "control" ventilation when building or retrofitting dwellings has not been widely available. The ASHRAE standard for ventilation does not tell how to measure the ventilation. Furthermore, the American household cannot be expected to measure incoming air quality to determine if it is "cleaner" or "dirtier" than the household air. The practical aspect of the dilemma is that a "safe" level of infiltration can be deduced from a review of data on older, tight dwellings. The minimum level for air leakage suggested on this basis is 1 1/2 air changes per hour at 0.1-inch vacuum across the home wall. This suggested minimum does not replace the ASHRAE or Building Code air change requirements. Figure 3 showed acceptable minimum velocity pressures for various sized dwellings. This figure is used as a guide. In the event of questions or the need to be precise in measurement, the air changes per hour should be calculated as follows.

$$ACPH = \frac{65,802}{V_H} \cdot \frac{r^2}{144} \sqrt{\frac{h_v}{d}}$$

where:

ACPH = air changes per hour

V_H = inhabited volume of house, cubic feet

r^2 = radius of test fan duct, inches

h_v = observed velocity pressure in fan duct,
inches H_2O

d = density of air corrected for relative humidity,
temperature, and altitude, pounds per cubic foot

The suggested minimum limit for air leakage is based only on deduction and judgment. No scientific data were found to substantiate or deny this figure. It is believed to be a conservative figure, but one which should be reviewed repeatedly in the light of research now underway at the Lawrence Berkeley Laboratory as well as unpublished studies made by Geomet for EPRI. It is possible that this minimum value may be reduced following this research thus making further energy savings feasible.

LITERATURE SURVEY

The literature relating to air infiltration and its effect on energy use in buildings is not extensive. The 223 citations in the Bibliography represent a very comprehensive selection of pertinent literature. The 43 citations in the references are recommended as the most practical for those interested in applying infiltration knowledge to the design, construction, and retrofit of dwellings. These references were selected because of the length of the Bibliography, the need for a shortened and more workable list of references, and the objective of making this working list one of practical value.

Ventilation is the intentional displacement of air through specified openings.²⁶ Infiltration is the leakage of air through cracks around doors, windows, plumbing, walls, floors, etc. which cannot effectively be controlled by the occupants. This leakage is due to driving forces created by wind, indoor-outdoor temperature difference, and HVAC equipment.

Commercial buildings usually maintain a positive pressure relative to outdoors to reduce infiltration. Of course, exfiltration is greatly increased and energy consumption is much higher. Some figures show the heating load to be as much as three times higher.²⁷

One of the causes of energy waste in a building is due to the unwanted air leakage. In fact, heat escapes primarily by conduction and infiltration. Infiltration alone can account for as much as 40 percent of the total heat loss.²⁸ A Princeton University report, sponsored by the Energy Research and Development Administration (ERDA), showed that infiltration in the winter can cause an average of 33.4 percent of the heat loss in a townhouse.²⁹ The study also showed that with wind velocities over 20 mph this heat loss can be as high as 60 percent.³⁰

How temperature and wind affect infiltration has been studied and is relatively well understood. If the inside of a building is warmer than the outdoor air, the entire structure acts as a chimney; hot air rises and leaks out sucking cold air in. Temperature difference and building height contribute to this effect. A two-story house with

68°F inside temperature and 30°F outside temperature will produce a chimney effect leakage equivalent to a 10 mph wind.³¹

Air flow due to wind over and around a building creates regions of differing static pressure. Wind pressures are positive on the windward side causing air to be forced through the cracks, and negative on the leeward side resulting in outflow of air. Pressures on the other sides are negative or positive, depending on wind angle and building shape. Static pressures over building surfaces are almost proportional to the velocity head of the undisturbed air stream. Both wind and temperature effects are usually included in modeling. Tamura and Wilson measured the infiltration into two Canadian homes. The results of their study indicated that:

- Infiltration was proportional to wind speed when T was low (summer)
- Infiltration was proportional to T when the wind speed was low
- Infiltration is affected by furnace action (oil-fired house)
- Infiltration components are not additive.³²

The general areas of air infiltration which have been researched are: (1) methods to quantify infiltration rate (amount of air being replaced each hour), and (2) techniques to lower the infiltration rate into the structure. Quantification of leakage can be accomplished by prediction or actual measurement with varying degrees of accuracy.

Two techniques used to predict air infiltration rate, the Air Change Method and the Crack Method, are described in the American Society of Heating, Refrigerating, and Air Conditioning Engineers (ASHRAE) Handbook of Fundamentals. The Air Change Method assigns a certain number of air changes per hour to each room depending upon its relative location in the building and the number of doors and windows.³³ The use of the Crack Method requires the length of all windows and outside doors. Leakage characteristics for various kinds of windows and doors have been measured and then listed in air change values per unit length.³⁴ This method is based on the assumption that the main source of infiltration is around windows and doors. The Crack Method is considered to be the more accurate of the two recognized prediction methods.³⁵

Another approach to predicting infiltration rates is with the use of a computer. There is little confidence in

numerical simulation, however. Standard formulae do exist to estimate air exchange rates, but they are at best rough approximations. A standard model or standard constants cannot be used because infiltration is dependent on very large non-calculable variables such as quality of workmanship and habits of occupants. In addition, these variables interacting with each other cause the model to become unmanageably complex. The following lists some of the variables which should be taken into consideration when a model is being developed.

- Indoor-outdoor temperature difference
- Occupant activity
- Site of building (i.e., surrounding trees, hills and other structures)
- Wind speed and direction
- Heating/cooling energy source
- Exhaust fans
- Chimneys
- Building construction
- Porosity of materials of construction
- Steady state pressure versus pulsation and eddies
- Number and habits of occupants

Usually, wind and temperature alone are included in modeling.

$$INF = A + B\Delta T^m + CW^{1/n} \quad (36)$$

where:

INF = infiltration rate

A,B,C = regression coefficients

ΔT = indoor-outdoor temperature difference

W = wind speed

m,n = arbitrarily selected exponents

At least one model has also included crack length.

$$\text{INFPI2} = \beta_0 C_T (A \Delta P_T + B \Delta P_W)^{1/2} \quad (37)$$

where:

INFPI2 = infiltration

C_T = total equivalent crack length

A, B = relative weights

ΔP_W = theoretical pressure difference across enclosure due to wind effect, inches of water

ΔP_T = theoretical pressure difference across enclosure due to stack effect, inches of water

Air infiltration or building air leakage can be measured (rather than predicted) by two published methods; Tracer Gas Diffusion and Air Pressurization. In the Tracer Gas Diffusion procedure, a small amount of gas is introduced into the building and, after thoroughly mixing, the rate of decay in concentration is measured at varying intervals. The air changes per hour (ACPH) can then be determined from this logarithmic decay of the gas with respect to time. This is based on the assumption that there is perfect mixing and steady state flow. The exponential decay law holds under these restrictions (or if the system approaches these conditions).

$$C = C_0 e^{-It} \quad (38)$$

where:

C = tracer gas concentration at time = t

C_0 = tracer gas concentration at time = 0

I = air change rate

t = time

In multi-room structures, perfect mixing may not be an appropriate assumption. One of three methods can be used to achieve better mixing. If the building has central heating and cooling, the fan system would be operated continuously. The tracer gas is injected into the return air slowly and samples are drawn from the supply outlet. Where there is no central fan system, fans are placed in various locations to circulate the gas. Fans which circulate over 360 degrees (e.g., oscillating or upright fans) are preferable.³⁹ In this case, the tracer gas is released and sampled in several points. The third method is to operate fans only for initial

mixing and before sampling. A typical sampling period is 15 minutes.⁴⁰ The samples are injected into a gas chromatograph. The equipment is tuned for the particular tracer gas so the concentration of the gas in air can be determined. In addition, wind speed and direction, indoor-outdoor temperature, barometric pressure, and percent relative humidity are recorded. The weather data is usually taken every hour from a portable meteorological station.

Many different gases have been used as tracers, some with more success than others. Ideally, the gas would have the following characteristics:

- Inert, odorless, tasteless, non-polar, and not absorbed
- Nonflammable and non-explosive
- Non-toxic and non-allergenic
- Measurable at very low concentrations
- Not a normal constituent of air yet have a similar molecular weight
- Transported and dispersed as other atmospheric gases
- Easily and inexpensively measurable with high reliability
- Commercially available.^{41,42}

Gases which have been used as tracers are helium, hydrogen, methane, ethane, carbon monoxide, carbon dioxide, nitrous oxide, sulfur hexafluoride, and chloroethene.⁴³ Presently, sulfur hexafluoride is one of the more commonly used gases. Although it can be determined at extremely low concentration (1 part per 10^{-9}), its molecular weight is much higher than most molecules found in air.⁴⁴

From the tracer gas data, there are a number of ways to determine the air changes per hour. Included are three methods.

- Finite Differences - The air changes per hour rate is calculated after each sampling using the following equation:

$$I = \frac{L}{V} = \frac{1}{(t_{i+1} - t_i)} \ln \frac{C_i}{C_i + I} \quad (45)$$

where:

L = leakage rate

V = room volume

t_i = time at i th interval

C_i = tracer concentration at i th sampling interval

Decay - Ratios are calculated for C/Co ratios of 3/4, 2/3, 1/2, 1/3, and 1/4 using:

$$ACPH = \frac{-\ln c_n}{t_n}$$

where:

$c_n = C/c_0$ of 3/4, 2/3, 1/2, 1/3, or 1/4

Graphical - Concentration versus time is plotted on semilog paper (time is the linear axis). The data points should fall on a straight line. The slope of the line is equal to the exchange rate.

$$I(ACPH) = \frac{\ln c_1 - \ln c_2}{t_2 - t_1} \quad (46)$$

The graphical method is less sensitive to errors in concentration measurement and also has the advantage of giving a visual display of the exponential decay.

The second method used to measure air infiltration rate requires the use of a fan assembly. This is a piece of equipment which is cylindrical in shape; 54 inches long, 18 inches in diameter. A 3/4 horsepower motor is used to drive the fan which simulates wind. The air is forced through a honeycomb air rectifier to attain laminar flow. The differential between inside house pressure and outside pressure is sensed by a pitot tube grid. The fan is connected to a 20-inch square opening. Generally, a window works well. Pressure differentials, both static and induced, are monitored with a magnehelic or incline manometer. This device is depicted in Appendix D.

On-site weather data, indoor-outdoor temperature, barometric pressure, wind speed and direction, and percent relative humidity are recorded. Before any data are taken, the house is inspected to insure all windows, doors, dampers, and vents are closed. The induced velocity pressure data are recorded at various static pressure, usually between 0.0 and 0.3 inches of water. From the velocity pressure measured at this known static pressure, the forced air changes per hour can be calculated using the density of the air and the volume of the structure. Dwyer Instruments suggests the use of the following equation to calculate the cfm through the fan assembly.

$$\dot{v} = S(v) = S(1096.7) \sqrt{\frac{h_v}{d}}$$

where:

\dot{v} = volumetric flow, cubic feet per minute

v = velocity, feet per minute

S = cross-sectional area of fan assembly

h_v = induced velocity pressure, inches of water

d = density of air, pounds per cubic foot

The induced ACPH can be determined by the equation:

$$\text{Induced ACPH} = \frac{\dot{v} \cdot 60}{V}$$

where:

V = volume of structure (heated volume)

One of the biggest problems in this method is determining the volume to be used. Some houses have unheated basements or crawl spaces; meaning that the area is theoretically unheated. Very rarely is the unheated area effectively sealed off from the heated area. This is especially a problem in homes with central heating and cooling (duct work). Only the heated volume is involved in the calculations of Induced ACPH.

Relating this forced ACPH value to the actual value, such as that measured by the Gas Diffusion Method, is difficult and only one attempt to do so has been disclosed. The real value of the fan assembly lies in its ability to pinpoint the air leakage into a building. When the house is under a vacuum, which is induced by the fan, it is possible to feel the areas where air is entering.

It may be seen from the foregoing discussion that the literature relating to theory and measurement of air infiltration is the largest segment of the references. This is because relatively little has been published relating to the practical aspects of minimizing infiltration and quantifying the cost effectiveness of the various options for minimizing air infiltration. Work by Princeton University and the Texas Power & Light Company represent the pioneering efforts to locate the sources and causes of air infiltration.⁴⁷ On-going studies sponsored by the Electric Power Research Institute have confirmed many of the earlier

findings and have located some new leaks in homes.⁴⁸ These same studies have suggested methods of air infiltration retrofit. The Texas Power & Light work has gone on to suggest some fundamental changes in new construction methods. These are generally consistent with official Swedish recommendations, although there is a much heavier emphasis on vapor barriers as infiltration stops in the cold climate of Sweden.⁴⁹

The cost effectiveness of air infiltration construction and retrofit is the least addressed topic in the literature. There is very general agreement that almost all the conventional recommended practices short of storm windows and doors are cost effective in the three to four year term. Only the National Bureau of Standards was found to have addressed quantification of various energy saving practices and their payback period in various parts of the country.⁵⁰

Some of the more recent literature references have raised the question of the effect of low air infiltration on occupant health and safety.⁵¹ The Lawrence Berkeley Laboratory is becoming very active in studying this question.⁵² At the present time, there appears to be no generalized concern that American houses may be too tight. However, there is concern that growing emphasis on air infiltration may result in homes becoming too tight unless modern standards are soon adopted.

CONCLUSIONS

- *Air infiltration has been found to be a major contributor to heating/cooling energy costs in houses.
- *Air infiltration has been significantly reduced using rather simple, cost effective retrofit procedures in existing houses.
- *Air infiltration has been significantly reduced by making minor changes in materials and methods of new construction.

RECOMMENDATIONS

- Use a special fan and duct assembly to measure the severity of induced air infiltration in existing dwellings.
- Use this fan to quickly and easily locate all points of air infiltration.
- Follow the step by step retrofit procedure in this report to significantly reduce air infiltration and reduce heating/cooling energy use.
- Use the special fan assembly to be certain that a building is not made too tight. A too tight building may pose health hazards to occupant.

REFERENCES

¹C. F. Sepsy, R. Godfrey, and B. Fussel, "Energy Usage Comparisons of Identical, Non-Inhabited Residential Homes with Two Types of Insulation and a Program Simulation of the Required Heating Loads", Ohio State University Environmental Control Group, 1976.

²National Warm Air Heating and Air Conditioning Association, Manual 2, 1950.

³"Planning, Building, and Selling Energy Efficient Homes in Florida", Florida State Energy Office.

⁴A. Elmroth, "Wall Insulated Airtight Buildings Design and Construction", Document D10:1978 PB 285861, Swedish Council for Building Research, 1978.

⁵ASHRAE Handbook of Fundamentals, 21, 1977.

⁶D. T. Harrje, R. H. Socolow, and R. C. Sonderegger, "Residential Energy Conservation - The Twin Rivers Project", ASHRAE Trans., 1977.

⁷G. E. Caffey, "Residential Air Infiltration", ASHRAE Preprint No. 2512, (1979).

⁸R. J. Johnson and O. G. Lee, "An Energy Efficient Residence - Performance and Cost", Paper to DoE and ASTM Conference, October 23, 1978.

⁹"Planning, Building, and Selling Energy Efficient Homes in Florida", loc.cit.

¹⁰J. E. Peterson, "Estimating Air Infiltration Into Houses", ASHRAE Journal, January 1979.

¹¹G. T. Tamura, "The Calculation of House Infiltration Rates", ASHRAE Transactions, V. 85, Part 1, (1979).

¹²G. E. Caffey, loc. cit.

¹³Ibid.

¹⁴Unpublished Investigation by Johns-Manville for EPRI.

¹⁵Ibid.

¹⁶ASHRAE Handbook of Fundamentals, loc.cit.

¹⁷D. T. Harrje, R. H. Socolow, and R. C. Sonderegger, "Residential Energy Conservation - The Twin Rivers Project", ASHRAE Transaction, V. 83, Part 1, (1977), pp. 458-477.

¹⁸G. E. Caffey, loc.cit.

¹⁹Unpublished Investigation by Johns-Manville for EPRI.

²⁰Ibid.

²¹National Warm Air Heating and Air Conditioning Association, loc.cit.

²²C. D. Hollowell and G. W. Traynor, "Combustion Generated Indoor Air Pollution", Lawrence Berkeley Laboratories Report LBL-7832, April 1978.

²³ASHRAE Handbook of Fundamentals, 8, 1977.

²⁴"Planning, Building, and Selling Energy Efficient Homes in Florida", op.cit., p. 14.

²⁵ASHRAE Standard 62-73.

²⁶"Planning, Building, and Selling Energy Efficient Homes in Florida", loc.cit.

²⁷G. T. Tamura and C. Y. Shaw, "Studies on Exterior Wall Air Tightness and Air Infiltration of Tall Buildings", ASHRAE Report, Vol. 82, 1976.

²⁸G. T. Tamura, "Measurement of Air Leakage Characteristics of House Enclosures", ASHRAE Report, Vol. 91, 1975.

²⁹C. E. Buckley, D. T. Harrje, D. T. Heiser, and M. P. Knowlton, "The Optimum Use of Coniferous Trees in Reducing Home Energy Consumption", Center for Environmental Studies, Report No. 71, May 1978.

³⁰Ibid.

³¹J. D. Higson, Building and Remodeling for Energy Savings, Craftsman Book Company, Solana Beach, California, 1977, p. 147.

³²G. T. Tamura and A. G. Wilson, "Air Leakage and Pressure Measurements on Two Occupied Houses", ASHRAE Report No. 1980, Vol. 70, 1964.

³³"Planning, Building, and Selling Energy Efficient Homes in Florida", loc.cit.

³⁴Ibid.

³⁵J. E. Hill and T. Kusuda, "Dynamic Characteristics of Air Infiltration", ASHRAE Report, 1975.

³⁶H. D. Ross and D. T. Grimsrud, "Air Infiltration in Buildings: Literature Survey and Proposed Research Agenda", University of California, Berkeley, California, 1978.

³⁷G. Reeves, M. McBride, and C. Sepsy, "Air Infiltration Model for Residences", ASHRAE Conference, Philadelphia, Pennsylvania, January 1979.

³⁸p. L. Lagus, "Proposed Standard Practice for Measurement of Air Change Rate of Buildings by the Tracer Dilution Technique", Systems, Science and Software, La Jolla, California, August 1978.

³⁹Ibid.

⁴⁰Ibid.

⁴¹p. L. Lagus, "Recommended Practice for Air Leakage Measurement by the Tracer Dilution Technique", Systems, Science and Software, La Jolla, California, 1978.

⁴²p. L. Lagus and R. D. Broce, "Air Leakage Measurements in Support of the Johns-Manville Corporation", Systems, Science and Software, La Jolla, California, January 1979.

⁴³Ibid.

⁴⁴p. L. Lagus, "Proposed Standard Practice for Measurement of Air Change Rate of Buildings by the Tracer Dilution Technique", loc.cit.

⁴⁵Ibid.

⁴⁶p. L. Lagus, "Air Leakage Measurements by the Tracer Gas Dilution Method", Systems, Science and Software, La Jolla, California, 1977.

⁴⁷G. E. Caffey, loc.cit.

⁴⁸Unpublished Investigation by Johns-Manville for EPRI.

⁴⁹National Warm Air Heating and Air Conditioning Association, loc.cit.

⁵⁰S. R. Petersen, "Retrofitting Existing Houses for Energy Conservation: An Economic Analysis", NBS Building Science Series 641974.

⁵¹C. D. Hollowell, J. V. Beck, and G. W. Traynor, "Impact of Reduced Infiltration and Ventilation on Indoor Air Quality in Residential Buildings", ASHRAE Transactions, Part I, 1979.

⁵²C. D. Hollowell and G. W. Traynor, loc.cit.

⁵³S. R. Petersen, loc.cit.

⁵⁴Ibid.

⁵⁵W. J. Rossiter, Jr. and R. G. Mathey, ed. "Criteria for Retrofit Materials and Products for Weatherization of Residences", NBS Technical Note 982, 1978.

⁵⁶Ibid.

⁵⁷"Windows and Doors", Conservation Guide 4, Minnesota Energy Agency.

⁵⁸S. R. Petersen, loc.cit.

⁵⁹"Consumer Guide to Caulking", Mechanix Illustrated, p. 10, September 1976.

⁶⁰W. J. Rossiter, Jr. and R. G. Mathey, loc.cit.

⁶¹"Weatherstripping and Caulking", Conservation Guide 5, Minnesota Energy Agency.

⁶²"Ever Heard of Retrofit", DoE/CS-0001, October 1977.

⁶³Northern States Power, Energy Efficient Shield Program.

⁶⁴TVA, The Super Saver Electric Home Program.

⁶⁵W. J. Rossiter, Jr. and R. G. Mathey, loc.cit.

⁶⁶See "Consumer Guide to Caulking"; W. J. Rossiter, Jr. and R. G. Mathey; "Weatherstripping and Caulking"; and "Ever Heard of Retrofit", loc.cit.

⁶⁷"Weatherstripping and Caulking", loc.cit.

⁶⁸D. T. Harrje, "Retrofitting, Plan, Action and Early Results Using the Townhouses at Twin Rivers", Princeton University Center for Environmental Studies, Report No. 29, June 1976.

⁶⁹R. H. Socolow, "The Twin Rivers Program on Energy Conservation in Housing: Highlights and Conclusions", Energy and Buildings, Vol. 1, No. 3, April 1978, pp. 207-224.

⁷⁰Seed and Nursery Catalog, Gurney Seed and Nursery Company, Yankton, South Dakota, 1979.

⁷¹Planting Guide, Henry Field Seed and Nursery Company, Shenandoah, Iowa, 1979.

⁷²Unpublished Investigation by Johns-Manville for EPRI.

⁷³R. L. Pozzo, J. Clarke, Jr., A. Stanton, and T. Scarritt, "Achieving an Energy Efficient New Home in Florida", Florida State Energy Office, December 1977.

⁷⁴Northern States Power, loc.cit.

⁷⁵TVA, loc.cit.

⁷⁶National Warm Air Heating and Air Conditioning Association, loc.cit.

⁷⁷Ibid.

⁷⁸R. J. Johnson and O. G. Lee, loc.cit.

⁷⁹National Warm Air Heating and Air Conditioning Association, loc.cit.

⁸⁰R. L. Pozzo, J. Clarke, Jr., A. Stanton, and T. Scarritt, loc.cit.

⁸¹ASHRAE Handbook of Fundamentals, 21, 1977.

⁸²R. L. Pozzo, J. Clarke, Jr., A. Stanton, and T. Scarritt, loc.cit.

BIBLIOGRAPHY

- Adamson, B. "Energy Management and Ventilation". Lund University Report: 1977.
- Anrens, E. A. and Williams, P. B. "The Effect of Wind on Energy Consumption in Buildings". Energy and Buildings 1:77-84, 1977.
- American Gas Association. American National Standard for Household Cooking Gas Appliances, Report ANSI Z21.1: 29-30, 1974.
- American Gas Association, British Gas Corporation, and Gaz de France. "Oxides of Nitrogen: A Critical Survey".
- Anapol'Skaya, L. E. and Gandin, L. S. "Environmental Factors in the Heating of Buildings". John Wiley & Sons: New York, 1975.
- Anderson, D. B. "Heat Loss Studies in Four Identical Buildings to Determine the Effect of Insulation". ASHRAE Transactions: 1942.
- Angus, T. C. "The Study of Air Flow, Ventilation, and Air Movement in Small Rooms as Effected by Open Fires and Ventilation Ducts". J. Inst. Heat. Vent. Eng.: 1949.
- ANSI/ASTM. "Standard Test Method for Rate of Air Leakage Through Exterior Windows, Curtain Walls, and Doors". ASTM Standard E 283-73: 1976.
- Arens, E. A. and Williams, P. B. "The Effect of Wind on Energy Consumption in Buildings". Energy and Buildings: 1977.

- ASHRAE Handbook of Fundamentals. "Infiltration and Natural Ventilation". Chapter 21: 1977.
- Bannfleth, D. R.; Moseley, T. D.; and Harris, W. S. "Measurement of Infiltration in Two Residences". Part I: ASHRAE Trans, 1957.
- Bannfleth, D. R.; Moseley, T. D.; and Harris, W. S. "Measurement of Infiltration in Two Residences". Part II: "A Comparison of Variables Affecting Infiltration", ASHRAE Trans., 1957.
- Bailey, A. and Vincent, N. D. G. "Wind Pressure on Buildings Including Effects of Adjacent Buildings". J. Inst. Civ. Eng.: 1943.
- Baird, G. "Air Change and Air Transfer in a Hospital Ward Unit". Build. Sci.: 1969.
- Baird, G. "Air Movement Studies at the Hairmyres Experimental Ward Unit". JIHVE: April 1969.
- Baker, M.; O'Byrne, J. M.; and Levy, A. M. "Estimating the Heat Loss from Slab Floors and Basements". Heating, Piping and Air Conditioning: November 1952.
- Bargetzi, S.; Hartmann, P.; and Pfiffer, I. "Messung des Natürlichen Luftwechsels in Nichtklimatisierten Wohnräumen". Schweizerische Bauzeitung 95: April 1977.
- Barrett, R. E. and Locklin, D. W. "Computer Analysis of Stack Effect in High-Rise Buildings". ASHRAE Trans. 74: Part II, 155-169, 1968.
- Baschiere, R. J.; Lockmanhekim, M.; Moy, H. C.; and Engholm, G. "Analysis of Aboveground Fallout Shelter Ventilation Requirements". ASHRAE Trans.: 1965.

- Basnett, P.; Mould, A. E.; and Siviour, J. B. "Some Effects of Ventilation Rate, Thermal Insulation, and Mass on the Thermal Performance of Houses in Summer and Winter". Energy and Housing: Special Supplement to Building Science, 1975.
- Beck, J. V.; Hollowell, C. D.; Lin, C. I.; and Pepper, J. H. "Design of a Mobile Laboratory for Ventilation Studies and Indoor Air Pollution Monitoring". Lawrence Berkeley Laboratory Report LBL-7817REV.: April 1978.
- Beyea, J.; Dutt, G. S.; and Woteki, T. H. "The Critical Significance of Attics and Basements in the Energy Balance of Twin Rivers Townhouses". Energy and Buildings 1: 1977, Reprinted in Saving Energy in the Home - Princeton's Experiments at Twin Rivers, ed. by R. H. Socolow (Ballinger), 1978.
- Beyea, J.; Harrje, D. T.; and Sinden, F. W. "Energy Conservation in an Old Three Story Apartment Complex". Energy Use Management: Pergamon, New York, 1977.
- Bilsborrow, R. E. and Fricke, F. R. "Model Verification of Analogue Infiltration Predictions". Build. Sci.: 1975.
- Blomsterberg, A. K. and Harrje, D. T. "Approaches to Evaluation of Air Infiltration Energy Losses in Buildings". ASHRAE Transactions: Vol. 85, Part 1, 1979.
- British Standard 4315. "Methods of Tests for Air and Water Penetration: Part I, Windows and Gasket Glazing Systems". 1968.
- Brown, W. G.; Wilson, A. G.; and Solvason, K. R. "Heat and Moisture Flow Through Openings by Convection". ASHRAE Trans.: 1963.
- Brundrett, G. W. "Ventilation, A Behavioral Approach". CIB Conference on Energy in Buildings: Building Research Establishment, April 1976.

- Budnitz, R. J.; Hollowell, C. D.; Rosenfeld, A. H.; and Nero, A. V. "The Relationship Between Human Disease from Radon Exposure and Energy Conservation in Buildings". Univ. of Calif.: LBL Report 7399, 1978.
- Burch, D. M. and Hunt, C. M. "Retrofitting an Existing Wood Frame Residence for Energy Conservation - Air Experimental Study". National Bureau of Standards: Building Science Series 105, 1978.
- Bursey, T. and Green, G. H. "Combined Thermal and Air Leakage Performances of Double Windows". ASHRAE Trans.: 1973.
- Caffey, G. E. "Residential Air Infiltration". Texas Power & Light Report, Dallas, Texas: 1976.
- Caffey, G. E. "Residential Air Infiltration". ASHRAE Preprint No. 1056: 1978.
- Caffey, G. E. "Residential Air Infiltration". ASHRAE Preprint No. 2512: 1979.
- Card, W. H.; Sallman, A.; Graham, R. W.; and Drucker, E. E. "Air Leakage Measurement in a Building by an Infrasonic Method". Tech. Report TR-79-1: Final Report NSF Grants Eng-75-23416 and Computer Environments, Dept. Electrical and Computer Engineering, Syracuse Univ., January 1978.
- Chang, S. G. and Novakov, T. Atmos. Environ. 9: 1975.
- Cholette, A. and Cloutier, L. "Mixing Efficiency Determinations for Continuous Flow Systems". Canadian Jour. Chem. Eng.: 1959.
- Christensen, G.; Brown, W. P.; and Wilson, A. G. "Thermal Performance of Idealized Double Windows, Unvented". ASHRAE Trans.: 1964.
- Coblentz, C. W. and Achenbach, P. R. "Design and Performance of a Portable Infiltration Meter". ASHRAE Trans.: 1957.

- Coblentz, C. W. and Achenbach, P. R. "Field Measurements of Air Infiltration in Ten Electrically Heated Houses". ASHRAE Trans.: 1963.
- Cockroft, J. P. and Robertson, P. "Ventilation of an Enclosure Through a Single Opening". Build. Environ.: 1976.
- Collins, B. G. and Smith, D. B. "Measurement of Ventilation Rates Using a Radioactive Tracer". J. Inst. Heat. Vent. Eng.: 1949.
- Condon, P. E.; Grimsrud, D. T.; Sherman, M. H.; and Kammerud, R. C. "An Automated Controlled-Flow Air Infiltration Measurement System".
- Cote, W. A.; Wade, W. A. III; and Yocum, J. "A Study of Indoor Air Quality". The Research Corporation of New England: EPA 650/4-74-042, 1974.
- Cover, L. E. "Modern Insulation Methods". Two Papers Presented Before the Institute of American Meat Packers. Copyright 1929: Armstrong Cork and Insulation Co.
- Cutler, S. J. and Young, J. L., Jr. ed. "3rd National Cancer Survey: Incidence Data". Monograph 41: DHEW Publication No. (NIH) 75-787, U. S. Department of Health, Education & Welfare, National Institutes of Health, 1975.
- Davenport, A. G. "The Application of Statistical Concepts to the Wind Loading of Structures". Proc. Inst. Civ. Eng.: 1961.
- Daynes, H. A. "The Theory of the Katharometer". Proceedings: Royal Society 97, 1920.
- Department of Housing and Urban Development. "Revision 6a to HUD's Minimum Property Standards for One- and Two-Family Dwellings, Thermal Insulation". 1978.

- Dewerth, D. W. and Himmel, R. L. "SP-8 Proceedings". 67th Annual APCA Meeting, Denver, Colorado: June 1974.
- Dick, J. B. "Experimental Studies in Natural Ventilation of Houses". J. Inst. Heat. Vent. Eng.: 1949.
- Dick, J. B. "Measurements of Ventilation Using Tracer Gas Techniques". Heat. Piping Air Cond.: 1950.
- Dick, J. B. and Thomas, D. A. "Ventilation Research in Occupied Houses". J. Inst. Heat. Vent. Eng.: 1951.
- Doeffinger, R. C. "Air Change Measurements Using a Tracer Gas Technique". Penn. State U. Report, Dept. of Arch. Eng.: March 1976.
- Drivas, P. J.; Simmonds, P. G.; and Shair, F. H. "Experimental Characterization of Ventilation Systems in Buildings". Environ. Sci. Technol.: 1972.
- Ducar, G. J. and Engholm, G. "Natural Ventilation of Underground Fallout Shelters". ASHRAE Trans.: 1965.
- Dutt, G. S. "The Effect of Material Porosity on Air Infiltration". Princeton Univ. Twin Rivers Project, Note 3: 1977.
- Dutt, G. S. "Humidity in Attics". Center for Environmental Studies Working Paper No. 41: October 1978.
- Dutt, G. S. and Beyea, J. "Attic Thermal Performance: A Study of Townhouses at Twin Rivers". Princeton University Center for Environmental Studies Report No. 53: September 1977.
- Dutt, G. S. and Beyea, J. "Hidden Heat Losses in Attics - Their Detection and Reduction". Princeton University Center for Environmental Studies Report No. 77: December 1978.

Dutt, G.; Beyea, J.; and Sinden, F. W. "Attic Heat Loss and Conservation Policy". ASME Paper 78-TS-5: 1978. Presented at Energy Technology Conference, Houston, Texas.

Elkins, R. H. and Wensman C. E. "Natural Ventilation of Modern Tightly Constructed Homes". Paper Presented at the American Gas Association Institute of Gas Technology Conference on Natural Gas Research and Technology. Chicago, Illinois: February-March, 1971.

Ellett, W. E. "Recent Advances in Understanding the Risk Due to the Inhalation of Radon Daughters". Radon Workshop, February 1977. Report No. HASL-325. Health and Safety Laboratory, U. S. Department of Energy: New York, 1977.

Elliott, J. M. and Baker, M. "Heat Loss from a Heated Basement". ASHRAE Transactions: 1960.

Elmroth, A. "Airtight Buildings, Design and Construction". Swedish Royal Institute of Technology: 1978.

Energy and Buildings. Special Princeton Issue, Vol. 1, No. 3. Elsevier Sequoia, S.A. Lausanne, Switzerland: April 1978.

Etheridge, D. W. "Crack Flow Equations and Scale Effects". Build. Environ.: 1972.

Foord, N. "Use of Gas and Particle Tracers in the Study of Infection Transmission". Proceedings of Fourth International Symposium on Aerobiology Held at Technical University at Enschede, The Netherlands. Oosthoek Pub. Co. ed. J. F. Ph. Hers and K. C. Winkler.: Utrecht, 1973.

Foord, N. and Lidwell, O. M. "A Method for Studying Air Movement in Complex Occupied Buildings Such as Hospitals: Halocarbons as Gas Tracers Using Gas Chromatography". BSE: July 1973.

- Froehlich, D. P.; Hellickson, M. A.; and Young, H. G. "Ridge Vent Effects on Model Ventilation Characteristics". ASAE Trans.: 1975.
- Gabrielsson, J. and Porra, P. "Calculation of Infiltration and Transmission Heat Losses in Residential Buildings by Digital Computer". J. Inst. Heat. Vent. Eng.: 1968.
- George, A. C. and Breslin, A. J. "The Distribution of Ambient Radon and Radon Daughters in Residential Buildings in the New Jersey and New York Area". Presented at the Symposium on the National Radiation Environment III, Houston, Texas: April 1978.
- Goldschmidt, V. W. and Wilhelm, D. R. "Summertime Infiltration Rates in Mobile Homes". ASHRAE Preprint PH-79-10, New York: 1979.
- Gottling, K.; Domber, H.; Hilleger, H. G.; and Vogg, H. "Die Technik der Luftwechselbestimmung Mit Radioaktiv Krypton-85 Und Ihre Anwendung Auf Untersuchungen In Stallen". Gesund. Inc.: 1972.
- Graham, R. W. "Infrasonic Impedance Measurements of Buildings for Air Leakage Determination". M.S. Thesis. Syracuse University: 1977.
- Grimsrud, D. T.; Sherman, M. H.; Janssen, J. E.; Pearman, A. N.; and Harrje, D. T. "An Intercomparison of Tracer Gases Used for Air Infiltration Measurements". Lawrence Berkeley Laboratory Report 8394: November 1978.
- Grimsrud, D. T.; Sherman, M. H.; Diamond, R. C.; Condon, P. E.; and Rosenfeld, A. H. "Infiltration-Pressure Correlations: Detailed Measurements on a California House". ASHRAE Transactions, Vol. 85, Part 1: 1979.
- Grot, R. A. "A Low Cost Method for Measuring Air Infiltration Rates in Large Sample of Dwellings". Symposium of the ASTM Symposium of Air Infiltration and Air Exchange Rate Measurement. Washington, D. C.: March 1978.

- Grot, R. A.; Harrje, D. T.; and Johnson, L. C. "Application of Thermography for Evaluating Effectiveness of Retrofit Measures". Proceedings of the Third Biennial Infrared Information Exchange, AGA Corp. St. Louis, Missouri: 1976.
- Hambraeus, A.; Bengtsson, S.; and Laurell, G. "Bacterial Contamination in a Modern Operating Suite - Part 1, Effect of Ventilation on Airborne Particles". J. Hyg. Camb.: 1977.
- Handley, T. H. and Barton, C. J. "Home Ventilation Rates: A Literature Survey". Oak Ridge National Laboratory Report No. ORNL-TM-4318: 1973.
- Hall, R. E.; Martin, G. B.; Wasser, J. H.; and Bower, J. S. "SP-8 Proceedings". 67th Annual APCA Meeting, Denver, Colorado: June 1974.
- Harris-Bass, J.; Kavarana, B.; and Lawrence, P. "Adventitious Ventilation of Houses". Build. Serv. Eng.: 1974.
- Harrje, D. T. and Grot, R. A. "Automated Air Infiltration Measurements and Implications for Energy Conservation". Proceedings of the International Conference on Energy Use Management, Pergamon: New York. Tucson, Arizona: October 1977.
- Harrje, D. T.; Socolow, R. H.; and Sonderegger, R. C. "Residential Energy Conservation--The Twin Rivers Project". ASHRAE Trans.: 1977.
- Harrje, D. T. "Heat Pump Performance Measured Using Ten Residential Units Operating in the Northeastern United States". Energy Use Management - Proceedings of the International Conference. Vol II, ed. R. A. Fazzolare and C. B. Smith, Pergamon: New York, 1977.
- Harrje, D. T.; Hunt, C. M.; Treado, S. J.; and Malik, N. "Automated Instrumentation for Air Infiltration in Buildings". Center for Environmental Studies Report No. 13. Engineering Triangle, Princeton, New Jersey: 1975.

- Harrje, D. T. "Retrofitting, Plan, Action and Early Results Using the Townhouses at Twin Rivers". Princeton University Center for Environmental Studies Report No. 29: June 1976.
- Harrje, D. T. and Mills, T. A., Jr. "Air Infiltration Reduction Through Retrofitting". ASTM Special Publication, 1978. Presented at ASTM Meeting on Air Infiltration: March 1978.
- Harrje, D. T. "Details of the First-Round Retrofits". Energy and Buildings, Vol. 1: April 1978.
- Heldenbrand, J. L. ed. "Design and Evaluation Criteria for Energy Conservation in New Buildings". NBS Report NBSIR74-452: February 1976.
- Hill, J. E. and Kusuda, T. "Dynamic Characteristics of Air Infiltration". ASHRAE Trans.: 1975.
- Hitchen, E. R. and Wilson, C. B. "Review of Experimental Techniques for the Investigation of Natural Ventilation in Buildings". Build. Sci.: 1967.
- Hinrichs, R. S. and Wolfert, C. K. Fundamentals of Residential Attic Ventilation. H. C. Products Co., Princeville, Illinois: 1974.
- Hittman Associates. "Technology Assessment of Residential Energy Conservation Innovations". HUD PDR 117: May 1975.
- Hollowell, C. D.; Beck, J. V.; and Traynor, G. W. "Impact of Reduced Infiltration and Ventilation on Indoor Air Quality in Residential Buildings". ASHRAE Transactions, Part 1: 1979.
- Hollowell, C. D.; Budnitz, R. J.; Case, G. D.; and Traynor, G. W. "Generation of Gaseous and Particulate Air Pollutants from Indoor Combustion Sources: I. Field Measurements 8/75-10/75". Lawrence Berkeley Laboratory Report LBL-4416.

Hollowell, C. D.; Sudnitz, R. J.; and Traynor, G. W. "Proc. Fourth International Clean Air Congress". Tokyo, Japan: May 1977. The Japanese Union of Air Pollution Prevention Associations, 1977.

Hollowell, C. D. and Novakov, T. "Mobile Atmospheric Research Laboratory". Atmospheric Aerosol Research Annual Report, T. Novakov et al, 1975-76. Lawrence Berkeley Laboratory Report LBL-5214.

Hollowell, C. D. and Traynor, G. W. "Combustion-Generated Indoor Air Pollution". Proceedings of the 13th International Atmospheric Pollution Conference, Paris, France: April 1978.

Honma, H. "Ventilation of Buildings and Its Disturbances". Faibo Grafiska, Stockholm: 1975.

Hopkins, L. P. and Hansford, B. "Air Flow Through Cracks". Build. Serv. Eng.: 1974.

Doughten, F. C. and Schrader, C. C. "Air Leakage Through the Openings in Buildings". ASHRAE Trans.: 1924.

Howard, J. S. "Ventilation Measurements in Houses and the Influence of Wall Ventilators". Build. Sci.: 1966.

Howland, A. H.; Kimber, D. F.; and Littlejohn, R. F. "Measurements of Air Movements in a House Using a Radioactive Tracer Gas". J. Inst. Heat. Vent. Eng.: 1960.

Hunt, C. M. "Air Exchange and Ventilation System Measurements in the Norris Cotton Federal Office Building in Manchester New Hampshire". Report of Test to ERDA: 1977.

Hunt, C. M. and Burch, D. M. "Air Infiltration Measurements in a Four-Bedroom Townhouse Using Sulfur Hexafluoride as a Tracer Gas". ASHRAE Trans.: 1975.

- Hunt, C. M.; Porterfield, J.; and Ondris, P. "Air Leakage Measurements in Three Apartment Houses in the Chicago Area". National Bureau of Standards Report: 1977.
- Hunt, C. M., and Treado, S. J. "A Prototype Semi-Automated System for Measuring Air Infiltration in Buildings Using Sulfur Hexafluoride as a Tracer". National Bureau of Standards Technical Note 398: March 1976.
- Hutchinson, F. W. "Energy Savings Due to Changes in Design of Ventilation and Air Flow Systems". Energy and Buildings: 1977.
- IHVE Guide Book A. "Air Infiltration". Section A4: 1976.
- Jackman, P. J. "A Study of the Natural Ventilation of Tall Office Buildings". J. Inst. Heat. Vent. Eng.: 1973.
- Jackman, P. J. "Heat Loss in Buildings as a Result of Infiltration". Build. Serv. Eng.: 1974.
- Jacobi, W. "Relation Between Cumulative Exposure to Radon Daughters, Lung Dose, and Lung Cancer Risk". Noble Gases, ed. R. E. Stanley and A. A. Moghissi. U. S. Environmental Protection Agency, Las Vegas: 1975.
- Janssen, J. E.; Glatzel, J. J.; Torborg, R. H.; and Bonne, U. "Infiltration in Residential Structures". Paper Presented at ASME Winter Meeting, Atlanta, Georgia: November-December 1977. Appears in "Heat Transfer in Energy Conservation". ASME Pub. H20 106.
- Janssen, J. E. and Bonne, U. "Improvement of Seasonal Efficiency of Residential Heating Spaces". Engineering for Power: 1977.
- Janssen, J. E.; Glatzel, J. J.; Torborg, R. H.; and Bonne, U. "Infiltration in Residential Houses". ASME Symposium Proceedings, Atlanta, Georgia: November 1977.

- Janssen, J. E.; Torborg, R. H.; and Bonne, U. "Measurement of Heating System Dynamics for Computation of Seasonal Efficiency". ASHRAE Trans.: 1977.
- Jennings, B. H. and Armstrong, J. A. "Ventilation Theory and Practice". ASHRAE Trans.: 1971.
- Jones, G. E. and Kleppe, L. M. "A Simple and Inexpensive System for Measuring Concentrations of Atmospheric Radon-222". Lawrence Berkeley Laboratory Report UCRL-16952: 1966.
- Jones, M. E. "A Review of the Literature on the Structure of Wind Turbulence, With Special Regard to Its Effect on Buildings". Build. Sci.: 1968.
- Jones, P. M. and Wilson, C. B. "Wind Flow in an Urban Area". Build. Sci.: 1968.
- Jordan, R. C.; Erickson, G. A.; and Leonard, R. R. "Infiltration Measurements in Two Research Houses". ASHRAE Trans.: 1963.
- Kelnhofner, W. J.; Hunt, C. M.; and Didion, D. A. "Determination of Combined Air Exfiltration and Ventilation Rates in a Nine-Story Office Building". Proceedings of Conference on Improving Efficiency and Performance of HVAC Equipment and Systems for Commercial and Industrial Buildings, Vol. I, Purdue University: April 1976.
- Kelnhofner, W. J.; Hunt, C. M.; and Didion, D. A. "Determination of Combined Air Exfiltration and Ventilation Rates in a Nine-Story Office Building". Proceedings of the Conference on Improving Efficiency and Performance of HVAC Equipment and Systems for Commercial and Industrial Buildings, Vol. II, Purdue University: April 1976.
- Kendall, R. M.; Kelly, J. T.; and Lanier, W. S. "Prediction of Premixed Laminar Flat Flame Kinetics Including the Effects of Diffusion". Paper Presented at the Stationary Source Combustion Symposium, Atlanta, Georgia: September 1975.

- Kent, A. D.; Handegord, G. C.; and Robinson, D. R. "A Study of Humidity Variations in Canadian Houses". ASHRAE Trans.: 1966.
- Kiyoura, R. "International Comparison and Critical Analysis of Nitrogen/Dioxide Air Quality Standards". Paper No. 76-17.33, Presented at the 69th Annual Meeting of the Air Pollution Control Association, Portland, Oregon: June-July 1976.
- Konrad, A.; Larsen, B. T.; and Shaw, C. Y. "Programmed Computer Model of Air Infiltration in Small Residential Buildings With Oil Furnace". Third International Symposium on the Use of Computers for Environmental Engineering Related to Building, Banff, Alberta: May 1976.
- Kronvall, J. "Testing of Houses for Air-Leakage Using a Pressure Method". ASHRAE Trans.: 1976.
- Lagus, P. L. "Characterization of Building Infiltration by the Tracer Dilution Method". Energy: 1977.
- Laschoer, R. R. and Healy, J. H. "Statistical Analyses of Air Leakage in Split-Level Residences". ASHRAE Trans.: 1964.
- Lidwell, O. H. "The Evaluation of Ventilation". J. Hygiene, Cambridge 58: 1960.
- Loo, B. W.; Jaklevic, J. M.; and Goulding, F. S. "Fine Particles: Aerosol Generation, Measurement, Sampling, and Analysis". ed. B.Y.H. Liu. Academic, New York: 1976.
- Lovelock, J. E. "Electron Absorption Detectors and Technique for Use in Quantitative and Qualitative Analysis by Gas Chromatography". Anal. Chem.: 1963.
- Luck, J. R. and Nelson, L. W. "The Variation of Infiltration Rate With Relative Humidity in a Frame Building". ASHRAE Trans.: 1977.

- Malik, N. "Air Infiltration in Homes". Princeton University Center for Environmental Studies Report 58: September 1977.
- Malinowski, H. K. "Wind Effect on the Air Movement Inside Buildings". Proceedings of the Third International Conference on Wind Effects on Buildings and Structures, Tokyo: 1971.
- Marley, W. G. "The Measurement of the Rate of Air Change". J. Inst. Heat. Vent. Eng. 2: 1935.
- Mattingly, G. E. and Peters, E. F. "Wind and Trees--Air Infiltration Effects on Energy in Housing". Princeton University Center for Environmental Studies Report 20: May 1975.
- McIntyre, I. S. and Newman, C. J. "The Test of Whole Home for Air Leakage". Bre. Dept. of Environ.: 1975.
- Melia, R. J. W.; Florey, C. duV.; Altman, D. G.; and Swan, A. V. Brit. Med. J. 2: 1977.
- Merryman, E. L. and Levy, A. "Nitrogen Oxide Formation in Flames: The Roles of NO₂ and Fuel Nitrogen". Paper Presented at the Fifteenth Symposium (International) on Combustion, Tokyo, Japan: August 1974.
- Min, T. O. "Winter Infiltration Through Swinging-Door Entrances in Multi-Story Buildings". ASHRAE Trans.: 1958.
- National Academy of Sciences, National Academy of Engineering, Coordinating Committee of Air Quality Standards. "Air Quality and Automobile Emission Control, Vol II: Health Effects of Air Pollutants". NAS-NAE, Washington, D. C.: September 1974.
- Olsson, F. A. "Ventilation and the Draught-Proofing of Windows in Old Blocks of Flats". Lund Institute of Technology, Department of Building Science Report: 1977.

Ouden, H. Ph. L. "Prediction of the Anticipated Air Volume Passing Through Buildings by Means of the Air Current Analogue". Research Institute for Public Health Engineering, Publication No. 272, Delft, Holland: 1967.

Pearson, J. E. "Natural Environmental Radioactivity from Radon-222". U. S. Public Health Service Publication No. 999-RD-26: 1967.

Petersen, S. R. "Retrofitting Existing Houses for Energy Conservation: An Economic Analysis". NBS Building Science Series 64: 1974.

Peterson, J. E. "Estimating Air Infiltration Into Houses". ASHRAE Journal: January 1979.

Pettenkoffer, M. "Ueber Den Luftwechsel In Wohngebäuden". Munich: 1858.

Prado, R.; Leonard, R. G.; and Goldschmidt, V. W. "Measurement of Infiltration in a Mobile Home". ASHRAE Trans. 82, Part 2: 1976.

Reeves, G.; McBride, M.; and Sepsy, C. F. "Air Infiltration Model for Residences". ASHRAE Transactions, Vol. 85, Part 1: 1979.

Rossiter, W. J., Jr. and Mathey R. G. "Criteria for Retrofit Materials and Products for Weatherization of Residences". NBS Technical Note 982: 1978.

Rouse, R. E.; Nall, D. H.; and Harrje, D. T. "Energy Conservation: An Analysis of Retrofit Potential in United States Housing". Princeton University Center for Environmental Studies Report: January 1979.

Rubin, L. I. and Gittins, R. "Use of a Portable SF₆ Detector and Tracer Gas for Rapid Determination of Air Ventilation Rates". Unpublished Report.

- Sabine, H. J.; Lacher, M. B.; Flynn, D. R.; and Quindry, T. L. "Acoustical and Thermal Performance of Exterior Walls, Doors and Windows". National Bureau of Standards: November 1975.
- Sander, D. M. and Tamura, G. T. "Simulation of Air Movement in Multi-Story Buildings". Second Symposium on the Use of Computers for Environmental Engineering Related to Buildings, Paris: June 1974.
- Sasaki, J. R. and Wilson A. G. "Air Leakage Values for Residential Windows". ASHRAE Trans.: 1965.
- Schraeder, T. "A Two-Parameter Model for Assessing the Determinants of Residential Space Heating". Princeton University Center for Environmental Studies Report 69: June 1978.
- Schutrum, L. F.; Ozisik, N.; Baker, J. T.; and Humphreys, C. M. "Air Infiltration Through Revolving Doors". ASHRAE Trans.: 1961.
- Sepsy, C. F.; Jones, C. D.; McBride, M.; and Blancett, R. "OSU/EPRI Final Report--Chapter 9, Air Infiltration". OSU/EPRI Final Report, Environmental Control Group, Dept. of Mechanical Engineering, Columbus, Ohio: 1977.
- Sepsy, C. F.; Godfrey, R.; and Fussel, B. "Energy Usage Comparisons of Identical Non-Inhabited Residential Homes With Two Types of Insulation and a Program Simulation of the Required Heating Loads". Ohio State University Environmental Control Group: 1976.
- Shaw, C. Y. "A Method for Predicting Air Infiltration Rates for a Tall Building Surrounded by Lower Structures of Uniform Height". ASHRAE Transactions, Vol. 85, Part 1: 1979.
- Shaw, C. Y. and Jones, L. "Air Tightness and Air Infiltration of School Buildings". ASHRAE Transactions, Vol. 85, Part 1: 1979.

- Shaw, C. Y.; Sander, D. M.; and Tamura, G. T. "Air Leakage Measurements of the Exterior Walls of Tall Buildings". ASHRAE Trans.: 1973.
- Shaw, C. Y. and Tamura, G. T. "The Calculation of Air Infiltration Rates Caused by Wind and Stack Action for Tall Buildings". ASHRAE Trans.: 1977.
- Shaw, B. H. and Whyte, W. "Air Movement Through Doorways--The Influence of Temperature and Its Control by Forced AirFlow". Build. Serv. Eng.: 1974.
- Shelton, J. W. "The Energy Cost of Humidification". ASHRAE J.: 1976.
- Sinden, F. W. "Theoretical Basis for Tracer Gas Measurements of Air Infiltration". Princeton Univ., Twin Rivers Project, Note 5: March 1976.
- Sinden, F. W. "Wind, Temperature, and Natural Ventilation". Princeton Univ., Twin Rivers Project, Note 6: June 1976.
- Sinden, F. W. "A Two-Thirds Reduction in the Space Heat Requirement of a Twin Rivers Townhouse". Energy and Buildings, Vol. 1: April 1978.
- Sinden, F. W. "Conductive Losses in Basements". Princeton University Center for Environmental Studies, Twin Rivers Note No. 4: February 1976.
- Sinden, F. W. "Multichamber Theory of Air Infiltration". Building and Environment: 1978.
- Smith, E. G. "Feasibility of Using Models for Predetermining Natural Ventilation". Texas A&M Univ., Research Report 26: 1951.
- Smith, F. and Wilson, C. B. "Parametric Study of Airflow Within Rectangular walled Enclosures". Build. Environ.: 1977.

Snihs, J. O. "The Significance of Radon and Its Progeny as Natural Radiation Sources in Sweden". Noble Gases. ed. R. E. Stanley and A. A. Moghissi, U. S. Environmental Protection Agency, Las Vegas: 1975.

Sonderegger, R. C. "Dynamic Models of House Heating Based on Equivalent Thermal Parameters". Ph.D. Dissertation, Princeton University: September 1977.

Sprenger, H. "Experimentelle Stromungsuntersuchungen Im Versuchs-Auditorium Der Eth Zurich". Gesund. Ing.: 1971.

Sterling, T. D. and Kobayashi, D. M. Environ. Res. 13: 1977.

Stricker, S. "Measurement of Air-Tightness of Houses". ASHRAE Trans. 81: 1975.

Svetlov, K. S. "Calibration of Air Exchange in Multi-Story Buildings Using Electronic Computers". Vodosnabzeni Sanitaria tekhnika 11: 1966.

Swedjemark, G. A. "Radon in Dwellings in Sweden". Presented at the Symposium on the National Radiation Environment III, Houston, Texas: April 1978.

Swift, J. L. "The Status of Indoor Air Pollution Research". Geomet Report No. EF-547: 1976.

Tamura, G. T. "The Calculation of House Infiltration Rates". ASHRAE Transactions, Vol. 85, Part 1: 1979.

Tamura, G. T. "Measurement of Air Leakage Characteristics of House Enclosures". ASHRAE Trans. 81: 1975.

Tamura, G. T. "Computer Analysis of Smoke Movement in Tall Buildings". ASHRAE Trans.: 1969.

Tamura, G. T. "Analysis of Smoke Shafts for Control of Smoke Movement in Buildings". ASHRAE Trans.: 1970.

- Tamura, G. T. "Measurements of Air Leakage Characteristics of House Enclosures". ASHRAE Trans.: 1975.
- Tamura, G. T. and Shaw, C. Y. "Studies on Exterior Wall Air Tightness and Air Infiltration of Tall Buildings". ASHRAE Trans. 82: 1976.
- Tamura, G. T. and Shaw, C. Y. "Studies on Exterior Wall Air Tightness and Air Infiltration of Tall Buildings". ASHRAE Trans.: 1976.
- Tamura, G. T. and Wilson, A. G. "Air Leakage and Pressure Measurements on Two Occupied Houses". ASHRAE Trans.: 1964.
- Tamura, G. T. and Wilson, A. G. "Pressure Differences for a Nine-Story Building as a Result of Chimney Effect and Ventilation System Operation". ASHRAE Trans.: 1966.
- Tamura, G. T. and Wilson, A. G. "Pressure Differences Caused by Chimney Effect in Three High Buildings". ASHRAE Trans.: 1967.
- Tamura, G. T. and Wilson, A. G. "Building Pressures Caused by Chimney Action and Mechanical Ventilation". ASHRAE Trans.: 1967.
- Tamura, G. T. and Wilson, A. G. "Pressure Difference Caused by Wind on Two Tall Buildings". ASHRAE Trans.: 1963.
- Tamura, G. T. and Wilson, A. G. "Natural Venting to Control Smoke Movement in Building Via Vertical Shafts". ASHRAE Trans.: 1970.
- Teitsma, G. J. and Peavy, B. A. "The Thermal Performance of a Two Bedroom Mobile House". NBSIR 76-1182: January 1977.
- Tipping, J. C.; Harris-Bass, J. N.; and Nevrala, D. J. "Ventilation--Design Considerations". Build. Serv. Eng.: 1974.

Torrance, V. B. "Wind Profiles Over a Suburban Site and Wind Effects on a Half Full-Scale Model Building". Build. Sci.: 1972.

Tsuchiya, T. "Numerical Calculation of Room Air Movement--Isothermal Turbulent Two Dimensional Case". Building Research Institute, Tokyo, Paper 62: January 1976.

U. S. Congress, Committee on Interstate and Foreign Commerce, Subcommittee on Health and the Environment, House of Representatives, Clean Air Act Amendments-1975, Hearings, Washington, D. C.: 1975.

USEPA, "A Preliminary Evaluation of the Control of Indoor Radon Daughter Levels in New Structures". EPA-520/4-76-018, Office of Radiation Programs, Washington, D. C.: 1976.

Wade, W. A.; Cote, W. A.; and Yocum, J. E. "A Study of Indoor Air Quality". APCA Journal, Vol. 25: September 1975.

Warren, P. R. "Ventilation Through Openings on One Wall Only". Building Research Establishment Report: August 1977.

Warren, P. R. and Webb, B. C. "Air Supply for Domestic Combustion Appliances". Build. Environ.: 1976.

West, D. L. "Contaminant Dispersion and Dilution in a Ventilated Space". ASHRAE Trans.: 1977.

White, P. F. "Effects of Landscape Development on the Natural Ventilation of Buildings". Texas A&M Univ., Research Report 45: 1954.

Williams, K. "Planning and Building the Minimum Energy Dwelling". Craftsman Book Co., Solana Beach, California.

Wilson, A. G. "Influence of the House on Chimney Design". ASHRAE Trans.: 1961.

World Health Organization. *Ambio* 6: 1977.

Woteki, T. H.; Dutt, G. S.; and Beyea, J. "The Two-Resistance Model for Attic Heat Flow: Implications for Conservation Policy". Energy - The International Journal 3: 1978.

Woteki, T. H. "Some Effects of Retrofits on Interior Temperatures in a Sample of Houses". Princeton University Center for Environmental Studies Working Paper No. 31: 1977.

Yamagishi, K.; Nozawa, M.; Yoshie, T.; Tokumoto, T.; and Kakegawa, U. "A Study of NO_x Emission Characteristics in Two Stage Combustion". Paper Presented at the Fifteenth Symposium (International) on Combustion, Tokyo, Japan: August 1974.

APPENDIX A

SOURCES OF AIR INFILTRATION

The following list of air leakage sources in homes is presented in the approximate order of frequency of occurrence disclosed by the studies of the Texas Power & Light Company and Johns-Manville.

Bottom of All Walls

Wallboard and plaster are not, in most cases, extended to the subfloor nor are they sealed to the sole plate or subfloor. Thus, any leakage within a wall will permit air to infiltrate under the wall and from behind baseboard trim.

Electric Fixtures Including Medicine Cabinets, Outlets, Switches, Fixtures, Etc.

These items are mounted in walls or ceilings and are not sealed so that air can leak through face plates, mounting holes, or from behind face plates, flanges, etc. Drilling of the top wall plate for electric wiring penetrations is a very common source of unconditioned air within walls. Recessed light fixtures are a common source of infiltration.

Around and Through Windows

Some windows are poorly designed and built permitting air leakage no matter how well they are installed. Careless or improper installation will permit air infiltration around even the best windows. Leakage between frame and wall is more common than leaks between the frame and sash. Failure to latch the window securely may permit leakage.

Heating/Cooling Ducts

Leaking ducts in unconditioned space add energy costs. Improper installation of ducts may create infiltration sites. This can be especially true at delivery registers and in the construction behind return registers. The delivery ducts may leak conditioned air to unconditioned space and return ducts pull unconditioned air to the energy source. Good construction practice calls for the taping of all metal duct joints in unconditioned space.

Vent Fans in Bathroom, Kitchen, and Attic

The dampers used on household vent fans frequently are not effective in preventing air leakage. Air may also leak around the outside of those appliances if they are not properly installed. Use of vent fans to exhaust conditioned air adds to the problem of infiltration.

Fireplace Fit

Quite often, the junction of masonry and frame construction in residential buildings will offer a ready path for air. Cracks may be a product of construction techniques or may open up because of differential movement between the two types of construction.

Door Fit

Doors are frequently fitted and hung at the job site. Doors to outside and to unconditioned space frequently leak quite badly because they are poorly fitted.

Plumbing Fixtures

The space around pipes which penetrate floors, walls, etc. form an easy path for air movement.

Clothes Dryer Vent

Air frequently leaks around the vent pipe and the one way valve has not proved to be an effective barrier against air blowing in the pipe.

Flues to Combustion Furnaces and Heaters

Flues are almost always open to the atmosphere. Automatic vent dampers can be used (where permitted by code) to close off some or all of the open flue when there is no combustion. Metal flues through walls and roofs can be a source of leakage around the outside of the flue.

Access to Unconditioned Space (Crawlspace, Attic, Etc.)

Access ways to unheated or uncooled areas deserve the same attention as exterior windows and doors. However, present construction practices do little to seal off these areas.

Stair Steps and Risers Over Unconditioned Space

This is usually found in open plan bi-level and tri-level houses. One set of stairs open to conditioned space is frequently located over unconditioned space and air from this space readily passes through the joints in stairway construction.

Garage-House Connection

Joints where construction changes direction or material are frequent sites for infiltration cracks. This may be caused by differential movement concentrating at the joint or may be due to poor construction techniques.

Bathtub and Shower Stall Fit

These units may be installed before the wallboard or plaster is applied. Thus, open wall space behind the units results in air leaks around the units and through plumbing penetrations.

Fireplace Damper

These dampers all too often fit poorly, operate with difficulty, and may be blown open by a strong wind.

Interior Trim Around Windows and Doors Including Closet Doors

Air may be found leaking from behind decorative trim because of construction at the headers or because outside and inside sheathings are not properly trimmed up to the frame opening.

Air Conditioners (In-Wall, In-Window)

Gasketing and weatherstripping around air conditioners is seldom found to fully prevent air leakage. Vibration of the units may accelerate opening of cracks.

Doorbells, Smoke Alarms, Thermostats, and Electric Demand Controllers

These are all somewhat similar in that mounting hardware and wire penetrations may create paths for air leaks.

Closet Door Runners

These tracks may be mounted before the floor or ceiling are properly completed thus leaving a clear opening to unconditioned space.

Sill and Sole Plates

Roughness in foundation surfaces and subfloor irregularities make it impossible to seal out air leakage with untreated sill and sole plate joints. This is one of the major contributors to bottom-of-the-wall leakage which was the most common infiltration location.

Furred walls on Masonry Construction

Furring strips may be carried from floor to unconditioned spaces above the ceiling creating a clear path for air movement.

Dropped Ceilings

This type of framing usually exposes the intersecting wall to unconditioned attic space.

The following list of additional infiltration sources is recounted for reference when surveying buildings for retrofit. Each item on this list occurred in less than one out of ten buildings.

- *Sewer Pipe Penetration
- *Wood Panelling on Studs or Furring
- *Basement Floor Drain
- *Toilet Paperholder
- *Telephone Cord
- *Soil Pipe to Basement
- *Door Latch
- *Skylight
- *Porous Masonry
- *False Ceiling Beam
- *Mail Chute (Slot)
- *Laundry Chute

APPENDIX B

MATERIALS FOR REDUCING AIR INFILTRATION

GLASS MAT/ADHESIVE SYSTEM

Fiber glass mat applied with a special adhesive has proved to be especially effective in sealing off infiltration at the sole plate-floor junction. This has been found to be the most common and one of the more serious sources of air infiltration. Caulking may not be permanently effective in sealing the joints between vertical walls and horizontal floors. The glass mat reinforced system provides the strength and elasticity needed in such an application.

The procedure to be followed in sealing the wall-floor junction is as follows:

Materials:

- *Fiber Glass Mat, Johns-Manville Type 7115, 3-inch wide rolls or equivalent.
- *Adhesive, Specification Chemicals, Inc., Boone, Iowa, White Plastic Adhesive. Hadley Adhesive Division of Sherwin Williams, St. Louis, Missouri, Code 1181 Adhesive.

Method:

- *Carefully remove the baseboard from wall. This can be done by driving nails through with the proper size nail set or pin punch. A finishers pry bar may also be used to pry the boards loose.
- *Loosen carpet or floor covering to expose a 1 to 3-inch width of subfloor. This is not necessary where a wood finish floor or concrete extend to the junction with the wall surface.
- *Prepare wall and floor surfaces by scraping or brushing away all dirt, dust, and loose construction materials.
- *Apply adhesive at a rate sufficient to wet the wall and floor about 2-inch wide on wall and 1-inch wide on floor using a nylon bristle brush along the floor-wall joint. Adhesive width on finish floor should not exceed width of baseboard.
- *Seat the glass mat into the wet adhesive. Use a putty knife or other suitable tool to smooth the mat and work out all bubbles and wrinkles.
- *Apply a second coat of adhesive over the glass mat surface to complete the impervious barrier. The first coat of adhesive should be allowed to set the mat

firmly before second coat application. Drying time for the first coat will usually be 15 to 30 minutes depending on temperature and humidity. Total usage of adhesive for the two coats is 60 to 75 square feet per gallon.

*Reinstall floor covering and base plates when the system has dried tack-free.

The glass mat/adhesive system has also proved effective for sealing walls which have cracked permitting air leakage. In this case, the glass mat is applied dry, like wallpaper, to the adhesive coated wall. Use an overlap joint, then trim to fit as in applying floor covering sheet goods. The final coat of adhesive will leave the wall prepared for final painting or wall covering. When walls are treated with this system, it is generally useful to remove window and door trims to permit extending the glass mat over cracks between frames and wall surfaces.

Strips of the glass mat can be applied between window or door frames and wall underneath the interior decorative trim when air leaks are found at these joints.

REPLACEMENT WINDOWS AND DOORS

Replacement windows and doors are perhaps misleading terms. When a prime window or door needs to be replaced because of rot, damage, or other conditions not correctable with caulking, weatherstripping, and possibly installation of storm windows or doors, it should be replaced with a new prime unit of thermally improved design and fabrication. Prime windows and doors are discussed later in this section.

STORM WINDOWS

Storm windows are used to cover existing windows. Properly installed, they may reduce infiltration and will increase insulating value of the window assembly. They are of significant value in reducing infiltration only when the existing window has sash leaks or has deteriorated to the point that caulking and weatherstripping cannot be made effective. It has been estimated that an infiltration reduction of only 10 percent will be achieved when storm windows are applied over tight fitting weatherstripped, prime windows.⁵³ The payback period for storm windows has been estimated by the National Bureau of Standards for various size windows in various climates.⁵⁴ The extremes of these estimates may range from 23 years for a 4-foot by 5-foot unit in 2000 to 4000 degree day climates to 1 year for a 2-foot by

2-foot unit in 8000 and more degree day climates. These estimates are based on varying fuel costs. The charts in this study are helpful in making a decision on the installation of storm windows based upon energy costs and heating/cooling climate.

There are many choices of materials and types of storm windows as indicated in Table B-1.

TABLE B-1. STORM WINDOW TYPES & MATERIALS

<u>FRAME MATERIAL</u>	<u>FINISH</u>	<u>STYLE</u>
Aluminum	Mill	Fixed
	Anodized	Double Track
	Painted	Triple Track
	Vinyl Clad	
Wood	None	Fixed
	Treated	
Rigid Polyvinyl Chloride	Integral Color	Double Track
		Triple Track
None	Flexible, Clear Plastic Glazing	
	Rigid, Clear Plastic Glazing with Surrounding Weatherstripping	

Fixed position storm windows may contribute to a ventilation problem and might also influence ease of emergency exit or entrance.⁵⁵ They are usually the least expensive of the window types. Wood fixed position windows are usually installed on the outside window casing. Appearance of the installation may sometimes be a consideration. Fixed storm windows must be removed when warm weather arrives if the prime window is to be used for ventilation.

Aluminum windows of the triple track and double track combination styles are probably most commonly used. They are usually supplied with a self-storing screen insert. Mill finish aluminum is not recommended because of potential corrosion problems especially in saline atmospheres. Selection of anodized, painted, lacquered, or vinyl clad finishes may be on the basis of price and initial appearance.

Rigid vinyl frame storm windows are rather new and have no long performance history upon which to judge them.⁵⁶ Their construction principles and operation are similar to aluminum units.

Glazing materials in storm window units may be glass, clear plastic (acrylic), or break resistant clear plastic (polycarbonate). Selection of glazing should be made on the basis of cost, safety, and utility. Glass is the least costly for service where the risk of breakage-in-service is low. Acrylic glazing may be more resistant to breakage at a higher price. Polycarbonate glazing is the best choice where severe abuse or breakage hazard is anticipated. Break resistant glazing may offer one potential risk in emergencies where it may be necessary to break the pane for exit or for fire fighting. For example, there have been reports of injuries to firemen attempting to break such panes where they had no advance warning that the glazing would repel a swinging ax.

Aluminum and vinyl frame combination storm windows are usually applied to the outside of the window frame trim using caulking on the back of the mounting flange and suitable fasteners supplied with the units. Alternatively, these units may, on certain types of wood double-hung prime windows, be recessed and mounted on the blind stop. The latter method may provide a neater appearing installation. It has also been reported that blind stop mounting may provide a tighter installation.⁵⁷

All storm windows offer a risk of moisture build-up between the prime and storm units. Many units are provided with weepholes in the bottom rail to prevent or reduce such a problem. While these weepholes may help in minimizing the risk of moisture problems, they are a source of infiltration.

Storm windows of all types are usually of local manufacture in most metropolitan areas. They can be obtained from the following types of sources:

- *Manufacturers Warehouse
- *Home Improvement Contractor
- *Building Supply Dealer
- *Mass Merchandisers

There is not a great deal of information to guide the purchasers in the selection of these windows. It is recommended that answers to the following questions be used as a guide.

- *Will a fixed unit be adequate and safe for the window(s) being treated?
- *Can the unit be conveniently removed and stored when not required to be in place?
- *Is color a consideration?
- *Is a screen needed as part of the unit?
- *Does the storm window being considered have weepholes to combat moisture built-up?
- *Does the unit being considered appear to be sturdy and well made?
- *Are sash tracks weatherstripped?

Finally, the following standards should be applied to the purchase of storm windows.

- *Aluminum Combination Storm Windows - ANSI/AAMA1002.9, 1977, "Voluntary Specifications for Aluminum Combination Storm Windows for External Applications".
- *Wood Frame Storm Windows - ANSI/NWMA I.S. 2-73, "Wood Windows", Section 3.
- *Rigid Vinyl Frame Storm Windows - Frame extrusions shall comply with NBS Voluntary Product Standard PS 26-70.

Frameless clear plastic glazing may be flexible, at least 0.306-inch thick, or rigid. The flexible sheet may be applied on the outside or inside window frame by folding over the edge of an oversize sheet and tacking or stapling directly to the frame. The fasteners may be driven through lath strips placed over the perimeter of the plastic for extra reinforcement. This sort of window treatment, while reported to be effective in reducing infiltration, is temporary; good for only about one season in outside application. Many people view this sort of window treatment as unsightly. The newer rigid plastic application to inside window frames uses a soft or foam plastic faced channel or edge margin to effect a friction fit in the window frame. Reports on the effectiveness of this type of treatment were not available at the time of this writing.

STORM DOORS

Storm doors are used for the same reason as storm windows; to reduce infiltration and heat conduction through an opening in the structure -- the prime door. Storm doors are generally available made from the same materials and sold through the same sources as aluminum, wood, and rigid vinyl storm windows. The NBS study on retrofitting for energy conservation suggests that storm doors are seldom justified on a short payback basis of less than ten years.⁵⁸ It appears that storm doors are worthy of consideration only in cold climates with over 14,000 degree days and having high costs of heating energy. The NBS study offers guidelines for estimating the payback period for storm doors.

Storm doors, unlike storm windows, are required by the Consumer Products Safety Commission Safety Standard for Architectural Glazing Materials, Part 1201 to have safety glazing. This Standard is mandatory and supersedes Building Codes. In addition, it is recommended that storm doors be purchased in compliance with the following standards.

- *Aluminum Frame - ANSI/AAMA 1102.7, 1977, "Voluntary Specifications for Aluminum Storm Doors".
- *Wood (Pine) Frame - ANSI/NWMA I.S. 5073, Section 3, "Ponderosa Pine Doors".
- *Wood (Other) Frame - FHDAI Standard FHDA/6-77, Section 3, "Industry Standard for Douglas Fir, Western Hemlock, and Sitka Spruce Doors and Blinds".
- *Rigid Polyvinyl Chloride - NBS Voluntary Product Standard PS 26-70. Note that this applies only to the extruded frame and not the quality or performance of the door itself.

Other questions concerning quality of fabrication, sturdiness, and auxiliary hardware should be answered on first-hand inspection of candidate doors as was suggested for storm windows.

Storm doors should be mounted on the outside door trim. The mounting flange should be caulked before installing the door with screws provided with the unit. The bottom of the door should have an adjustable PVC or neoprene sweep. Total installation including sweep adjustment must be in accordance with the manufacturers instructions.

CAULKING MATERIALS

Caulking materials are perhaps one of the most cost effective infiltration reducing items. There are a number of guides to selecting the correct caulk for the job at hand. 59,60,61,62

The following general guidelines are recommended.

- *For interior use where the caulk will be covered by trim, use caulk of the oil and resin type meeting Federal Specification TT-C-00598c or ASTM Standard C 570-72.
- *For interior use where the caulk will be exposed, use caulk meeting the above specifications and which is sold as "self-skinning" or "paintable".
- *For all exterior use, select any of the following three types based on a comparison of cost. If the caulk will be exposed, select one which is sold as "self-skinning" or "paintable".

Latex Caulk meeting ASTM C 834-76
Butyl Rubber Caulk meeting Federal Specification
TT-S-001657C
Acrylic Caulk meeting Federal Specification
TT-S-00230C

- *There are high performance caulks whose use may be indicated in special circumstances and especially where the previously listed caulks have not given satisfactory service.

Polysulfide Caulk meeting Federal Specification
TT-S-00230C
Polyurethane Caulk meeting Federal Specification
TT-S-00230C
Silicone Caulk meeting Federal Specification
TT-S-001543A

Always refer to the manufacturers recommendations and instructions to be certain that the caulk will be suitable for each application.

Where to caulk is a question frequently addressed by many publications. Two utilities with energy efficient programs offer the following list:

- *Between tops of windows and siding
- *Between tops of doors and siding

- * Joints between window frames and siding
- * Joints between door frames and siding
- * Between window sills and siding
- * At siding corners
- * Between sill and foundation
- * Penetrations in outside walls
- * Penetrations in ceilings to unconditioned space
- * Between porches and main house
- * Where chimney or masonry meets siding
- * Where storm windows meet window frame except for drain holes.^{63,64}

To this list the National Bureau of Standards has added:

- * window and door glazing
- * Wall to wall joints
- * Skylights
- * Ducts, vents, and other penetrations through walls
- * Air conditioners to window vents
- * Attic floor/chimney/siding gaps.⁶⁵

This combined list is excellent. It is also a good list for routine outside maintenance to prevent water as well as air penetration. Recent studies disclosed many additional areas inside the building which may require caulking to reduce air infiltration:

- * Ducts, vents, and other penetrations from crawl space to conditioned space
- * Wiring, plumbing, refrigerant penetrations of upper and lower wall plates
- * Masonry fireplace/wall intersection. It may be necessary to remove decorative trim and mantel.

- *Panelled wall perimeter. It may be necessary to remove decorative trim.
- *Between plumbing fixtures such as tubs and shower stalls and walls
- *Sliding door tracks
- *Joints in stair steps and risers over unconditioned space
- *Around recessed medicine cabinet
- *Doorbell
- *Smoke alarm
- *Around telephone cord
- *Around recessed toilet paperholder.

Follow the manufacturers instructions carefully. Be certain that all surfaces receiving caulk are clean, dry, and above the minimum temperature stated on the container - usually 40 or 50°F. Fill all large holes and cracks first with oakum or other non-oily backing materials as stated by the manufacturer. Generalized recommendations on the maximum size hole or crack which can be caulked without first filling with oakum vary somewhat. Should the manufacturer's directions not be explicit, it is recommended that any hole or crack having at least one dimension greater than 1/4-inch be filled prior to caulking.

WEATHERSTRIPPING

Weatherstripping should be used on all joints of doors, windows, and scuttles separating conditioned and unconditioned space. Prime windows meeting previously stated specifications are weatherstripped at the factory and should require no further weatherstripping. Pre-hung doors meeting previously stated specifications also should require no further weatherstripping. Application of weatherstripping to all moving joints of doors and windows is widely recommended.⁶⁶



There are many types and qualities of weatherstripping; some being general purpose, some specific purpose, some durable and some not. There is also a wide range of prices, but within a low price range so that all weatherstripping is reported to be cost effective.

A number of sources describe the use and benefits of the various types of weatherstripping.⁶⁷ Each of these has used an illustration-outline sort of presentation which is similar to Figure B-2. An addendum to Figure B-2 lists a guide as to cracks, joints, and openings which can benefit from weatherstripping and the type of weatherstripping which may be used in each application. Final selection, when more than one type is suitable, should be based on the information in Figure B-2 related to budget and service conditions.

One final note, this information on weatherstripping was believed to have been complete when Figure B-2 was prepared. Succeeding trips to a home center and perusal of Sunday newspaper home improvement sections have made it apparent that new materials and variations are being introduced almost daily. Some, like polypropylene spring V-strip, appear to be well designed, durable, and more attractive than their spring metal predecessor. Others, such as solid plastic replacement inserts for Schlegel pile still require ASTM E 283 testing for verification.

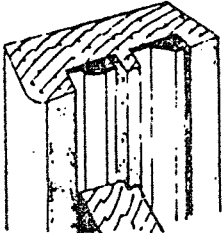
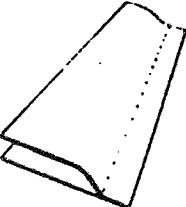
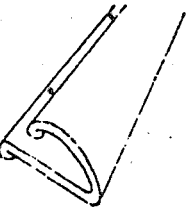
Figure B-2 - Weatherstripping

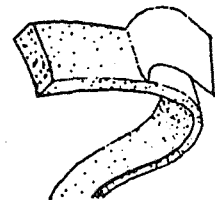
Name of Weatherstrip	Appearance	Where to Use	Approximate Cost	Effectiveness	Ease of Installation	Durability	Notes
Spring Metal Flat		Top & sides of door jamb, window side channels, top of upper sash, bottom of lower sash, sash meeting rail	\$0.20 per foot Aluminum \$0.35 per foot Bronze	Good	Fair	Good	
Spring Metal V		Top & sides of door jamb	\$0.30 per ft. Aluminum \$0.41 per ft.	Good	Fair	Good	
Spring Plastic V		Top & sides of door jamb	\$0.27 per foot	Good	Good	Unknown	

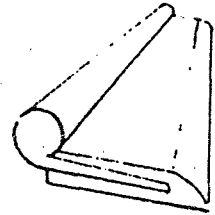
<u>Name of Weatherstrip</u>	<u>Appearance</u>	<u>Where to Use</u>	<u>Approximate Cost</u>	<u>Effectiveness</u>	<u>Ease of Installation</u>	<u>Durability</u>	<u>Notes</u>
Adhesive Lacked Foam		Bottom of lower sash, top of upper sash, door stop	\$0.08 per ft. $\frac{1}{2} \times \frac{1}{2}$ \$0.19 per ft. $\frac{3}{8} \times \frac{3}{4}$ \$0.28 per ft. $\frac{1}{2} \times \frac{3}{4}$	Good	Very Good	Poor	
Felt		See above	\$0.22 per ft. $\frac{3}{16} \times \frac{3}{4}$	Fair-Good	Good	Poor	
Tubular Gasket With or Without Metal Flange		Window sill, window casing, outside doorstop	\$0.30 per foot	Good	Good	Good	Visible

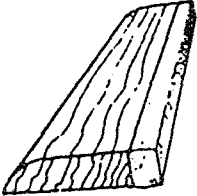
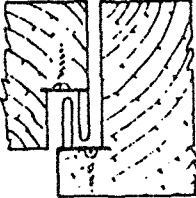
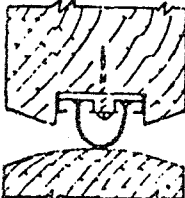
Name of Weatherstrip	Appearance	Where to Use	Approximate Cost	Effectiveness	Ease of Installation	Durability	Notes
Foam Edged Wood		Door stop	\$0.22 per foot	Fair-Good	Good	Poor	Visible
Interlocking Metal Channel		Top & sides of door jamb	\$1.25 per foot	Excellent	Difficult	Easily Damaged	Visible
Neoprene Bumper		Double doors	\$1.00 per foot	Good	Fair	Good	Many types

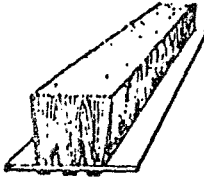
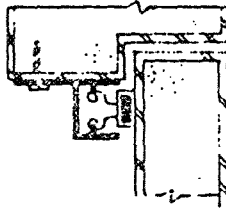
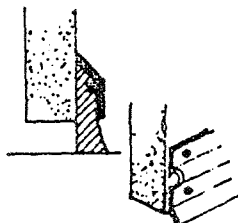
<u>Name of Weatherstrip</u>	<u>Appearance</u>	<u>Where to Use</u>	<u>Approximate Cost</u>	<u>Effectiveness</u>	<u>Ease of Installation</u>	<u>Durability</u>	<u>Notes</u>
Pile (Wool, Synthetic)		Replace in aluminum storm windows & doors	\$3.50 per ft. with aluminum backing \$0.12 per ft. unsupported	Fair	Good	Fair	
Magnetic Strip		Door jamb	\$6.60 per foot	Good	Fair	Good	
Sweep		Bottom of door	\$1.00 per foot	Fair-Good	Good	Good	Visible

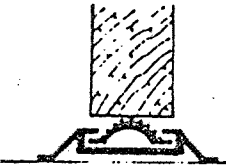
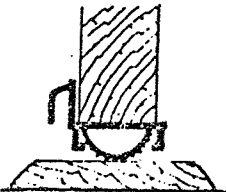
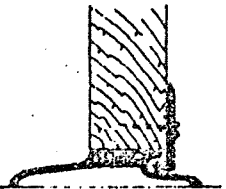
<u>Name of Weatherstrip</u>	<u>Appearance</u>	<u>Where to Use</u>	<u>Approximate Cost</u>	<u>Effectiveness</u>	<u>Ease of Installation</u>	<u>Durability</u>	<u>Notes</u>
Bulb Threshold		Threshold	\$2.67 per foot	Good, New	Good	Poor	
Door Shoe (Bulb Shoe)		Bottom of door	\$0.80 per foot	Good	Good	Good	
Interlocking Door Saddle		Bottom of door	\$3.00 per foot	Good, New	Good	Poor	

Guide to Weatherstripping

Location of Weatherstrip

Double or Single Hung Windows/Wood

Jamb
Bottom-Bottom Sash
Top-Top Sash
Bottom Rail Top Sash to
Top Rail Bottom Sash
Casing and Sill to Rails
Meeting Rail (single hung)

Sliding Windows/Wood

Horizontal Faces
Vertical Face

Hinged Windows/Wood

Metal Windows

Storm Doors & Windows

Rails to Channels & Jambs

Doors/Wood

Jamb

Stop (inside)
Stop (outside)
Astragal/Single Action
Double Door
Double Action
Bottom-Threshold

Doors/Metal

Choice of Materials

Flat Spring Metal
Adhesive Backed Foam
Felt

Flat Spring Metal (inside meeting faces)
Tubular Gasket on Fixed Parts
Tubular Gasket on Bottom of Fixed Sash

Flat Spring Metal on Fixed Faces
Adhesive Backed Foam, Felt

Tubular Gasket on Casing and Sill
Flat Spring Metal on Jamb and Other Fixed Faces

See same type of wood window for materials which may be used on wood casing where available. Otherwise, replace worn factory weatherstripping with identical material from manufacturer.

Replace Schlegel pile when worn down with same material.

V Spring Metal, Flat Spring Metal, V Spring Plastic, Metal Interlock, Neoprene Magnetic Gasket, Interlocking Metal

Adhesive Backed Foam, Felt
Tubular Gasket, Foam Edged Wood

V Spring Metal
Flat Spring Metal, V Spring Plastic, Overlap Gasket
Flexible Bumper
Interlocking Saddle, Two Piece Shoe, Sweep, Gasket
Threshold (vinyl bulb)

Replace worn weatherstripping with replacement parts from manufacturer.

LANDSCAPING

Trees are not frequently referenced as an effective means of reducing air infiltration. Yet, one study showed that trees had such a beneficial effect that it referred to trees planted upstream to the prevailing winds as "the first line of defense to limit air infiltration".⁶⁸ It has been reported that an effective windbreak can reduce air infiltration by 0.2 air changes per hour as measured by gas diffusion.⁶⁹ The planting of farmland windbreaks on the Great Plains and High Plains has been a rather common practice. County Agricultural Extension Agents throughout the country can provide specific recommendations on how to plant an effective windbreak. Some seed/nursery catalogues also provide recommendations.^{70,71}

VENT FAN COVERS

Vent fan covers are available to assist in sealing off kitchen and other wall mounted fans. One typical unit adheres to the fan face plate by magnets and is easily removed when fan use is required. Vent fan covers do not seem to be widely available. One type of unit is available from Sunset House, a mailorder specialty and gift company. It is, of course, not possible to cover the vent from clothes dryers. These have also been shown to be sources of air infiltration. The vent from electric clothes dryers may be exhausted to conditioned space in buildings where the warm air will not create a discomfort or cooling problem. The least expensive way to deal with the lint problem is to place a sheer nylon stocking over the flexible exhaust tube. This simple filter should be replaced frequently. Recommendations for replacing the stocking range from every two or three up to ten dryer loads. Frequent inspection is needed because a clogged stocking filter can create back pressure and overload the dryer. There are a number of commercial filter and damper devices beginning to appear on the market. All of these appear to have some merit because they exhaust the electric dryer to the inside eliminating the need for outside vent or providing a second positive damper for the outside vent. Gas dryers should always be exhausted to the outside of the building. In the case of gas dryer vents, the damper should be inspected frequently to insure that it closes properly when the dryer is not in use.

FIREPLACE GLASS DOORS

Glass doors for fireplaces can be effective in reducing infiltration if testing shows that the fireplace damper does not effectively prevent leakage. It has also been claimed in

manufacturers advertisements that glass doors equipped with one or more integral dampers can reduce loss of conditioned air when the fireplace is in use. ASTM and ANSI current indices show no standards for glass fireplace screens. It seems that good judgment based on careful inspection of various units must be the basis of selection. Follow carefully the installation instructions included with each unit. Glass fireplace screens are available from building supply dealers and fireplace specialty stores.

Outside air supply for fireplace combustion is an additional way to reduce infiltration during fireplace operation. An outside air supply combined with a glass screen having a closed damper or no damper will insure that conditioned air does not go up the flue resulting in replacement cold air infiltration. Fireplaces should be installed by a skilled contractor in accordance with ANSI/NFPA Standard 211-1972 and the local Building Code.

CHIMNEY CAPS

Fireplace chimney caps are a possible replacement for the fireplace damper. A chimney cap sits on top of the flue and is mechanically raised and lowered from inside the building. Chimney caps are not widely used or available. Their effectiveness has not been compared to that of a positive sealing damper.

AUTOMATIC VENT DAMPERS

Another device used to reduce infiltration by closing flues when they are not in use is the automatic vent damper for furnaces. This device was described in the Final Report on Task Order No. 1 under Contract DAAK 70-78-D-0002 and the effectiveness of several types of dampers is the subject of Task Order No. 7 currently in progress.

GASKETS

Air leaks through electrical fixtures, duplex outlets, switches, etc. can be minimized with resilient gasketing material. One gasket is a pre-cut sheet that seals around the switch or outlet between the wall and face plate. The second gasket fits over a plastic plug which is then inserted in unused outlets. These are relatively new products which have proved effective in tests in Denver.⁷² Kits containing gaskets and plastic plugs are sold by:

Armstrong Cork Company
Lancaster, Pennsylvania 17604 (Draft Sealer)

Glumen Group, Ltd.
8000 Cooper Avenue
Glendale, New York 11227 (Draft Ender)

The Vision Company
2843 Singleton Boulevard
Dallas, Texas 75212 (Energy Saver)

Manco Tape, Inc.
P. O. Box 685
Cleveland, Ohio 44107

Kits contain sufficient material for six to seven outlets plus two to three wall switches and cost about \$4.00 per packet.

DUCT TAPE

Duct tape, an aluminum faced adhesive tape, should be used to seal all joints in metal heating/cooling air ducts and returns. The conventional method of slip fit or crimped joints leak and are a major infiltration source as well as a source of conditioned air loss to unconditioned space. All joints should be checked as even previously taped joints may develop leaks. This tape may be purchased from building supply sources as well as plumbing and heating outlets. Fiber glass air ducts should not require treatment as their method of installation requires that joints be securely taped.

PLASTIC FILM

Polyethylene film is a powerful tool for use in minimizing air infiltration in new houses. It should be used to sheath over the framing members of walls and ceilings between all conditioned and unconditioned space. Minimum 6 mil film is used on the warm side of the walls and ceilings under the wallboard or paneling. Overlap and tape all seams. Cut the film very accurately around all electric boxes.⁷³ The value, even the necessity, of complete and effective vapor barrier has been stressed by NAHB and the Florida Power & Light Company. The Northern States Power Company, Nashville Electric Service, and Sweden go even further with recommendation of extending the vapor barrier under the finish floor.^{74,75,76} Much attention is paid to preparing for and maintaining vapor barrier integrity in the Swedish recommendations to reduce infiltration in new construction.⁷⁷

The use of a vapor barrier on the warm side of walls, ceilings, and floors is especially important as infiltration is reduced, because this encourages moisture buildup in the conditioned air. This moisture air must be prevented from passing into the wall and ceiling cavities in heating climates where it could condense, reducing effectiveness of insulation and possibly leading to rot of the wooden structure.

It has been claimed that when infiltration as measured by gas diffusion reaches 0.19 air changes per hour the moisture problems may become severe.⁷⁸ It was also claimed that existing houses do not have a moisture problem. The apprehension exists that growing and continued efforts to make houses more and more resistant to air infiltration may create moisture problems in heating climates. Vapor barriers are a necessity in combating the presence of moisture and keeping unwanted potentially damaging moisture out of walls, ceilings, floors, and unconditioned spaces under the roof.

SILL SEALER

Sill sealer, as the name implies, is a material used to fill spaces between the foundation and wood sill. It is installed when the house is built. The material compensates for irregularities in the surface of the foundation and should provide an air tight seal between the two members. EPDM rubber is recommended for use in Sweden.⁷⁹ In the United States, a compressible glass fiber blanket is promoted for the same use and is referred to in the trade as fiber glass sill sealer.

It seems unlikely that a porous glass fiber blanket can provide an air impervious barrier along the entire perimeter of a building. It is for this reason that glass fiber sill sealer be used in addition to caulking the joint between foundation and sill.⁸⁰

FOAM SHEATHING

Foam sheathing boards, offered as a component in one basic method for achieving a high R value frame wall, are also claimed to reduce air infiltration. These boards are designed to replace plywood and wood fiber sheathing boards in new construction. One study did demonstrate better infiltration resistance when a foamed polystyrene sheathing was directly compared to wood fiber board sheathing on similar houses.⁸¹ It went on to claim 10 percent reduction in heating energy due to causes other than an increase in wall insulation. It seems logical that a compressible and

conformable sheathing could help to reduce infiltration when no other steps have been taken to combat air entry. Foam sheathings may help to reduce infiltration. It appears, however, that their greatest effect may be in the area of contribution to the insulating value of walls.

Prime doors and windows may be made from wood, vinyl clad wood, steel, aluminum, and rigid vinyl (windows only). Selection of material should be principally based on utility and suitability, for the service conditions in the building, and insulation value of the units being compared. Prime doors and windows are also replacement units. Selection of prime doors and windows to minimize infiltration should include the following specifications.

WINDOWS

All windows should be certified to have a maximum air infiltration of 0.5 cfm per lineal foot of sash crack when tested according to ASTM E 283, latest revision. It has been reported that windows are available with an air infiltration rating of 0. Such windows would be desirable for minimizing infiltration.⁸²

Wood frame windows should comply with ANSI/NWMA I.S. 2-73.

Steel frame windows should comply with the Steel Window Institute Recommended Specifications for Steel Windows. They are to be constructed with continuous thermal breaks.

Aluminum frame windows should comply with ANSI/AAMA 302.9, 1977 and are to be constructed with continuous thermal breaks.

DOORS

All doors should be certified to have a maximum air infiltration of 1.0 cfm per square foot of door area when tested according to ASTM E 283, latest revision. Doors are to have the minimum amount of glazing consistent with safety and utility. Solid doors with no glass area should be used whenever possible.

Wood frame doors should meet Industry Standard FHDA 16-77 of the Fir and Hemlock Door Association and/or NWMA Industry Standard 1-73 of the National Woodwork Manufacturers Association.

Steel doors should meet SDI 103-7.6 of the Steel Door Institute.

Aluminum Sliding Glass Doors should comply with ANSI/AAMA 1102.7, 1977.

APPENDIX C

STEP BY STEP GUIDE TO INFILTRATION REDUCTION IN EXISTING
DWELLINGS (RETROFIT)

STRUCTURE

Determine if the structure is of braced or balloon frame construction (wall studs resting on sill plate).

The following is the initial procedure in retrofitting braced and balloon frame structures.

- Clean dust, dirt, etc. from top of sill and foundation. Caulk the joint between sill and foundation.
- Place mineral fiber insulation batts between the studs, full width, extending from the top of the sill to as far up the outside wall as the insulation batt can easily be pushed.
- Nail 1/2-inch gypsum wallboard bridging the studs and extending from top of foundation to underside of subfloor. Nail to sill and studs with vertical joints of adjoining panels centered over studs. Caulk joints between wallboard and sill, joists and subfloor.

otes:

This treatment of balloon frame construction may improve fire safety of the building by providing a minimum 15 minute fire stop over the cellar-to-attic channels in the outside walls.

This treatment will stop in-wall circulation of air from conditioned basements. Colder walls may be observed by building occupants in the cases where walls are not already insulated.

FAN INSTALLATION

Obtain a pressurizing fan and measuring devices as described in the test method presented in Appendix D.

Mount the fan in a window or doorway.

Seal the fan with duct tape so that no air can escape around the assembly.

Close and latch all windows and doors where appropriate.

Connect the pressure and velocity measuring devices according to the test method.

*If the building is equipped with a furnace and/or water heater having flues to the outside, it is suggested that the units be totally shut down according to manufacturers instructions. The flues may then be temporarily sealed off to facilitate maintenance of a vacuum in the building.

*Set the fan to evacuate the building and adjust the damper or fan speed to obtain a pressure drop across the wall of approximately 0.3-inch of water. The exact pressure drop is not critical at this point. A setting of 0.2-inch of water will suffice in most cases.

The building is now ready for air leakage inspection. The flow of air into the building will be obvious and can be detected by holding a hand or smoke stick over baseboards, window joints, electric outlets, etc. Each leak detected should be corrected with the appropriate treatment such as glass mat, caulk, weatherstripping, etc. It has been observed that different, non-professional operators develop their own effective routines for checking and fixing air leaks. A rigid procedure is not necessary to achieve energy savings through air infiltration reduction.

TREATMENT OF LEAKS

1. Maintain an 0.2 to 0.3-inch pressure drop across the wall by adjusting the fan speed or damper for each of the following inspections. Turn the fan off during treatment. Keep all doors to outside and unconditioned spaces closed. Close and latch all windows. Close all access to attic and crawl space if doors or hatches are available. Close fireplace damper and, if available, glass fireplace doors.
2. Inspect the house thoroughly and make a list of all leaks. At this point, the fan may be removed during the period when the first major leaks are treated.
3. Apply glass mat/adhesive system to intersections of floors and walls behind baseboards.
4. Inspect all electric switches, outlets, lights, doorbells, smoke alarms, thermostat load controllers, medicine cabinets, and other electrical fixtures. If leaks are found, proceed as follows.

- Caulk all wiring penetrations of sills, plates, floors, walls, and ceilings where these are easily accessible from attic, basement, or crawl space. Use only latex caulk around plastic coated wiring. Do not use latex caulk around metal shielded (BX) wiring and metal conduit.
 - Install switch and outlet gaskets.
 - Caulk space between service boxes and wall surface where gaskets of proper size and shape are not available.
5. Inspect all windows to determine which of the following treatments are required.
- remove interior trim and apply glass mat strips in adhesive over frame/wall joint
 - caulk window-outside wall intersections
 - weatherstripping on sliding channels of single and double hung units
 - weatherstripping on all joints of moving/stationary parts
 - replace cracked or broken panes
 - replace putty or glazing material between pane and sash
 - install storm windows
 - replace window
6. Inspect heating/cooling and return ducts in unconditioned space. Apply duct tape to all leaking joints.
7. Inspect all vent fans (damper closed). If leaks are found, caulk the vent sleeve-wall-ceiling intersections and install magnetic vent fan covers when the correct size is available. Consider alternate means of ventilation which would permit removal of the vent fan and sealing of the opening.
8. Install the fan and reinspect the treated areas for leaks. Reduce pressure drop to 0.1-inch water and read the velocity pressure. If the reading is in the reasonably tight range of Figure 3, the retrofit has been completed and you may proceed to Step 30. If not, proceed as follows.
9. Inspect the fireplace with fan set for a 0.2 to 0.3-inch pressure drop. If leaks are found, a careful inspection should be made to determine which of the following treatments may be necessary.
- Caulk all floor, ceiling, and wall intersections. It may be necessary to remove decorative trim and mantels.
 - Caulk exterior masonry-frame intersections.
 - Clean damper and seat.

- *Readjust damper.
- *Replace damper.
- *Install glass doors to supplement damper.
- *Replace cracked or broken glass in doors.
- *Replace air seal material behind glass doors.

10. Repeat Step 8 following fireplace treatment.

11. Inspect all doors to outside and unconditioned space with the fan set for a 0.2 to 0.3-inch pressure drop. If leaks are found, a careful inspection should be made to determine which of the following treatments may be necessary.

- *remove interior trim and apply glass mat strips in adhesive over frame/wall joints
- *caulk door frame-outside wall intersections
- *install or replace weatherstripping around door
- *install or replace unevenly worn threshold
- *install or replace door shoe or sweep
- *repair or replace glazing
- *install storm door
- *replace door

12. Repeat Step 8 following door treatment.

13. Inspect all plumbing penetrations of inside and outside walls with the fan set for a 0.2 to 0.3-inch pressure drop. If leaks are found, caulk the opening. It may be necessary to force glass fiber or oakum into the space prior to caulking.

14. Repeat Step 8 following plumbing treatment.

15. Inspect access to unconditioned space (attic, basement, crawl space, garage, etc.) with the fan set at 0.2 to 0.3-inch pressure drop. If leaks are found, the treatment selected will depend on circumstances encountered at each opening. A few examples are offered.

- *caulk and weatherstrip doors
- *install latches and weatherstripping on hatches
- *redesign opening to accept tight fitting hatch or door

16. Repeat Step 8 following access treatment.

17. Inspect stairs over unconditioned space. If leaks are found, caulk all joints between treads, risers, and framing. It may prove necessary to install, where practical, an insulated false ceiling under the stairs to achieve a permanent correction.

18. Repeat Step 8 following stair treatment.
19. Inspect garage-house and porch-house connections with the fan set for 0.2 to 0.3-inch pressure drop. Caulk all cracks and joints where leaks are found.
20. Repeat Step 8 following joint treatment.
21. Inspect the intersections of floors and walls with bathtubs and shower stalls with the fan set for a 0.2 to 0.3-inch pressure drop. Caulk all leaks.
22. Repeat Step 8 following tub and shower treatment.
23. Inspect clothes dryer vents and air conditioner penetrations with the fan set for a 0.2 to 0.3-inch pressure drop. If leaks are found, replace worn gasketing and weatherstripping, caulk where necessary, and replace dryer vents which have defective dampers. Consider inside venting of electric (not gas) dryers where practical. When this is done, the outside vent opening should be sealed to prevent air leaks.
24. Repeat Step 8 following dryer vent and air conditioner treatment.
25. Inspect, where accessible, the joint between sill plate and foundation with the fan set for a 0.2 to 0.3-inch pressure drop. If leaks are found, caulk the joint. Caulk both from the inside and outside wherever possible.
26. Repeat Step 8 following sill treatment.
27. If at this point the velocity pressure reading is not in the reasonably tight range, inspect the following areas with the fan set at a 0.2 to 0.3-inch pressure drop. Caulk all leaks.
 - *closet door runners
 - *sewer pipe penetration
 - *toilet paperholders
 - *telephone cords
 - *soil pipe through basement ceiling
 - *door latches
 - *skylights
 - *false ceiling beams
 - *mail slots and chutes
 - *laundry chutes
28. Repeat Step 8 following abovementioned treatments.

29. If at this point a satisfactory velocity pressure has not been achieved, go through the entire procedure again. Continued failure to achieve a satisfactory reading indicates the following treatments may be required for the indicated defects.

<u>DEFECT</u>	<u>TREATMENT</u>
Cracked Walls/Ceilings	Patch with spackle or plaster followed by glass mat treatment.
Porous or Cracked Masonry	Consult local masonry contractor for best treatment of actual condition.
Cellar Drain Pipe	No effective treatment yet proved. Install backwater valve if not present and if permitted by local Code Authority.

Other sources of leakage not disclosed by research to date may be discovered during building inspection. This is one of the benefits of the fan method in that it readily exposes leaks as a stream of air.

30. Remove the fan, clean up all tools and litter. Remove and discard the material used to seal off furnace and heater flues. Carefully inspect the flues to be certain that they are clean. Restart the furnace and heater according to manufacturers instructions.

APPENDIX D

TEST METHODS

Methods of test for measuring the air infiltration of buildings by the tracer gas dilution technique and induced air infiltration by the fan pressurization technique appear on the following pages.

Note the four methods described on the following pages have not been standardized by ASTM, ANSI, or testing laboratories. These methods must, for this reason, be viewed only as guides to be followed in studying the air leakage quality of buildings.

MEASUREMENT OF AIR CHANGE RATE IN BUILDINGS BY TRACER DILUTION TECHNIQUE

Scope

This method describes the tracer dilution measurement of air leakage in buildings. It is intended to be conducted only by those specifically trained in the skills required by this particular method.

Air leakage rate is difficult to assess because it is a function of building tightness and configuration, inside-outside temperature differences, wind velocity and direction, and possibly other factors such as quality of workmanship in construction, building maintenance, and the resistance of the building components to deterioration.

Definition of Terms

Air Leakage - The volume of air movement per unit time across the boundary of a building space. This movement tends to involve movement through cracks and porous surfaces.

Infiltration - Air leakage into a building space.

Exfiltration - Air leakage from a building space.

Air Change Rate (I) - Air leakage in volume units per hour divided by the building space volume expressed in air changes per hour (ACPH).

Tracer Gas - A gas which can be mixed with air and measured in very small concentrations making it possible to detect air movements and measure air exchange rates.

Summary of Method

Tracer Dilution Technique

A small amount of tracer gas is introduced into the test structure and the rate of change (decay) in tracer concentration is measured. The air change rate can be determined from the logarithmic decay rate of tracer concentration with respect to time.

The basic assumption underlying the tracer gas measurement of air change is that for perfect mixing with steady air flow, the loss rate of tracer gas concentration is proportional to its concentration.

This assumption leads to the following equation.

$$C = C_0 e^{-It}$$

where:

C = Concentration of tracer at time = t

C₀ = Initial tracer concentration

I = Air change rate

t = Time

Tracer Gas Characteristics

The desirable characteristics of a tracer gas are

- *Measurable at very low concentrations
- *Inert, non-polar, and not absorbed
- *Non-toxic, non-allergenic
- *Non-flammable and non-explosive
- *Easily and inexpensively measurable
- *Not a normal constituent of air
- *Measurable by a technique which is free of interference by substances normally in air.

No single gas fulfills all these conditions, but some tracer gases which have been used for air change rate measurements along with the instrumental technique used to sense the tracer are presented in Table D-1. Typical atmospheric background concentrations for these gases are presented in Table D-2.

Table D-1.

<u>Tracer</u>	<u>Measuring Apparatus</u>	<u>Maximum Allowable Concentrations In Air volume/volume</u>	<u>Minimum Detectable ppm</u>	<u>Toxicology</u>	<u>Chemical Inertness</u>	<u>Comments</u>
Hydrogen	Katharometer	4 percent (lower explosive limit)	200	Non-toxic	Extremely reactive in presence of O ₂ & heat or flame.	Flammable or explosive in presence of O ₂ & heat or flame.
Helium	Katharometer	---	300	Non-toxic	Non-reactive	Non-reactive
Carbon Monoxide	IR absorption, heat of absorption measurement, GC followed by reduction to methane & measurement with flame ionization detector	50 ppm	5	Combines with hemoglobin to produce anphyxia	Can be dangerous when exposed to open flame	Can also react with O ₂ in air in sufficient concentration. May explode when exposed to open flame.
Carbon Dioxide	IR absorption, GC with TCD	5000 ppm	1 70	Non-toxic	Very soluble in water	
Sulfur Hexafluoride	Electron capture, Gas chromatograph	1000 ppm	0.000002	Non-toxic	Chemically inert when pure	When heated to decomposition (550°C) toxic by-products may be formed.
Nitrous Oxide	IR absorption		1	Non-toxic	Very soluble in water	Can form explosive mixtures in air.
Ethane	Flame ionization detector, GC with FID	3 percent (lower explosive limit)		Non-toxic	Will burn when exposed to flame	May explode in presence of O ₂ & heat or flame.

Table D-2. Atmospheric Constituents

<u>Compound</u>	<u>Average Tropospheric Background Concentrations ppm</u>	<u>Typical Indoor & Urban Ambient Concentrations ppm</u>	<u>Sources</u>
H ₂	0.5	0.5	
He	5.2	5.2	
CO	0.1	5-50	Combustion
CO ₂	320	30-5000	Combustion
N ₂ O	0.3	0.3 to several ppm	Combustion
Ethane	1.5 x 10 ⁻³	0.1	Incomplete Combustion
SF ₆	10 ⁻⁸	<10 ⁻⁵	Telephone Switching Stations

Procedure

Injection and Mixing of Tracer Gas

A quantity of tracer is released at one or more points in the test building. The amount of tracer released should be sufficient to produce an easily discernible response in the gas measuring instrument. UNDER NO CIRCUMSTANCES SHOULD THE INITIAL TRACER GAS CONCENTRATION EXCEED THE OSHA TIME WEIGHTED AVERAGE FOR SUBSTANCES INCLUDED IN THE LATEST OSHA STANDARDS. Fans should be used to circulate the air within the structure in order to mix the gas thoroughly. Connecting doors, closet doors, and the like should be opened to allow unobstructed internal air flow. Several minutes should be allowed for mixing and the decay in tracer concentration as a function of time is then monitored.

Sampling of Tracer Gas

Use of the preceding equation implies perfect mixing of tracer with the air throughout the test. In multi-room structures this may not always be a good approximation. Measurements of samples taken from a number of sites may reveal the degree of uniformity of tracer concentration. In a building with central heating and air conditioning, the main fan is operated continuously. The tracer is introduced slowly into the return air and samples are drawn from a supply outlet at timed intervals. This method has convenience and lends itself particularly to automated procedures. Also, in occupied homes it may be the only method available for continuous monitoring. However, due to leaks in ductwork or elsewhere in the system, it may produce an incremental increase in the dilution rate. An alternate procedure is to operate portable fans at various points in the building, release tracer at several points, and perform multi-point sampling. A modification of these procedures is to operate fans only for initial mixing and shortly before sampling, using a sampling interval of 30 minutes or longer. Comparison of these procedures, making provision for normal statistical variations, may provide an estimate of the influence of fans on the infiltration rate.

When multi-point sampling is used, sensors are placed at strategic points in the test structure and fed to a central measuring terminal. Measurement of helium in air has been performed in this way. However, for methods which analyze air with a single measurement device, a sampling network may be used to bring blended air samples to the analyzer.

Data Analysis

The previous equation may be rearranged to:

$$I = \frac{1}{t} \ln \left(\frac{C_0}{C} \right)$$

where:

C = Measured time dependent concentration

C₀ = Measured initial concentration

I = Air change rate

t = Time (hours)

This is the starting point for several means of calculating ACPH from concentration and time data measurements.

Finite Difference Method

Air change per hour is calculated after each sampling using the finite difference form:

$$I = \frac{L}{V} = \frac{1}{(t_{i+1} - t_i)} \ln \frac{C_i}{C_{i+1}}$$

where:

L = Leakage rate

V = Room volume

t_i = Time at ith interval

C_i = Tracer concentration at ith sample interval

For measurement over N sampling intervals, one may form a mean and standard deviation according to:

$$\text{Mean } I = \bar{I} = \frac{1}{N} \sum I$$

$$\text{Standard Deviation} = S_I = \sqrt{\frac{\sum I^2 - (\sum I)^2 / N}{N-1}}$$

The air change rate, $I = \frac{L}{V}$, is "best fit" to the sample values of this parameter. The best fit for I is the mean and is determined from the test data as per the mean and standard

deviation equation previously stated. This method has the advantage of simplicity, but it is very sensitive to errors in concentrations or the effects of poor mixing, especially when short sampling intervals are used.

Decay Method

Concentration decay usually occurs quickly. This fact allows for rapid means of estimating I. For example, with time measured in minutes, the time for one-half of the initial concentration to decay is noted as $t_{1/2}$ and the I estimate is given by $41.59/t_{1/2}$.

Graphical Methods

Plot the natural logarithm of the concentration (on a linear scale) against time (in hours) on a linear scale. The measurements should fall on a straight line provided the air exchange rate remains constant. Pick two points on the line, with coordinates (Y_1, t_1) and (Y_2, t_2) where Y_i is the concentration at time t_i . I is given by:



The graphical method is less sensitive to errors in concentration than the previous methods. It has the further advantage that the graph provides a visual display of any departures from the exponential decay law. For a large number of tests or measurements, a multi-purpose computer program is useful.

Reporting

The report should include the information listed. As much of this information as possible should be included to facilitate intercomparison of data at a later time.

Measurement Characterization

Air Mixing - Method of initial mixing and method of maintaining mixing during the measurement if one is used.

Air Sampling - Location of sampling site, sample interval, initial sample time, method of sampling.

Tracer Gas - Type, initial concentration, method of introduction.

Detector - Type and method of calibration.

Type of Calculation - Simple mean, graphical.

Meteorological Conditions

Wind speed and direction (both maximum and average).

Temperature.

Barometric pressure.

Relative humidity.

Test Space Characteristics

Structure Type - Residential, commercial, industrial, other.

Location of Structure Relative to - (1) proximity to other structures (give type) and roadways, (2) proximity of surrounding terrain (give type, i.e., gullies, mountains, mounds, cliffs, etc.), and (3) structure orientation and elevation relative to Nos. 1 and 2.

Windows - Type, dimensions, number, location in test space.

Doors - Type, dimensions, number, location in test space.

Walls - Interior and exterior.

Noticeable areas of leakage.

Location of chimneys, vents, and other such specified openings.

Type and capacity of heating, ventilation, and air conditioning system.

Test Space Operating Characteristics

Doors - Open or closed.

Windows - Open or closed.

HVAC System - On or off.

Vent Fans - On or off.

Special Circumstances or Characteristics - Occupied or unoccupied

Indoor temperature.

Barometric pressure.

Relative humidity.

MEASUREMENT OF AIR CHANGE RATE IN BUILDINGS BY THE PRESSURIZATION/EVACUATION TECHNIQUE (Texas Power & Light Company)

Residential Air Leakage Test Procedure

Step 1 - Place air machine in any 20-inch or larger window.

*Tape filler boards in window and tape all cracks of that window caused by locating machine in window.

*Need 120 volt AC electrical supply available for 3/4 horsepower, 12 amp motor.

*Air machine will protrude out of the window and pull air from the residence.

Step 2 - Install manometer or other type differential pressure gauge to read pressure difference across residence wall.

*You may vary the air machine damper to create anywhere from 0 to 0.40 inches of water column pressure across the wall.

Step 3 - Install tubes between the air measuring station of the air machine and the Hi/Low junctions of the CFM meter.

Step 4 - Make sure that all doors, windows, exterior surface fans and dampers are closed.

Step 5 - Begin the test with the damper closed and gradually open it, at the same time taking CFM leakage readings as wall pressure differential is varied from 0 to 0.05, 0.10, 0.15, 0.20, 0.25, etc. Pulling a pressure differential on the home greater than 0.40 is not recommended.

*Machine will remove from 0 to approximately 3000 CFM from the residence depending upon leakage and size of home.

Step 6 - Data is usually obtained at 0.25 s.p. for item by item measurement purposes. Data is also obtained at 0.10 s.p. (approximately 15 mph wind equivalent) because this is typical wind design in the Dallas area.

*Thus far, the CFM leakage at 0.10 s.p. is used in determining air change rate or volume leakage per hour.

(For additional Test Procedure details, contact Technical Services Division of Texas Power & Light Company, Dallas, Texas.)

18-Inch Air Machine Parts List

<u>Item</u>	<u>Order Outlet</u>	<u>Stock No.</u>	<u>Approximate Cost</u>
18-inch Tubeaxial Fan	W. W. Grainger	4C249	\$ 93.00
3/4 HP Split Phase Motor	W. W. Grainger	6K624-2	64.00
4-inch Variable Pulley	W. W. Grainger	3X276-3	5.00
Air Measuring Station with Volume Meter	Cambridge Filter Corp.	FMSD-C18	193.00
Volume Control Damper	Loren Cook Co. Cat. 73-C	VCD-18	77.00
Companion Flange	Loren Cook Co.	18CV	21.00
Safety Screen	Loren Cook Co.	18-inch	24.00
*Differential Pressure Gage	Dwyer-Magnehelic	Series 2000	60.00
*Air Measuring Hood with Meter	Cambridge Filter Corp.	PMS-MV2	440.00
*Anemometer	Davis Instrument	A/2-4"	218.00
			<u>\$1,214.00</u>
		Approximate Metal Cost	<u>\$ 286.00</u>
			<u>\$1,500.00 TOTAL</u>

*Instruments which are necessary to make detailed air leakage studies.

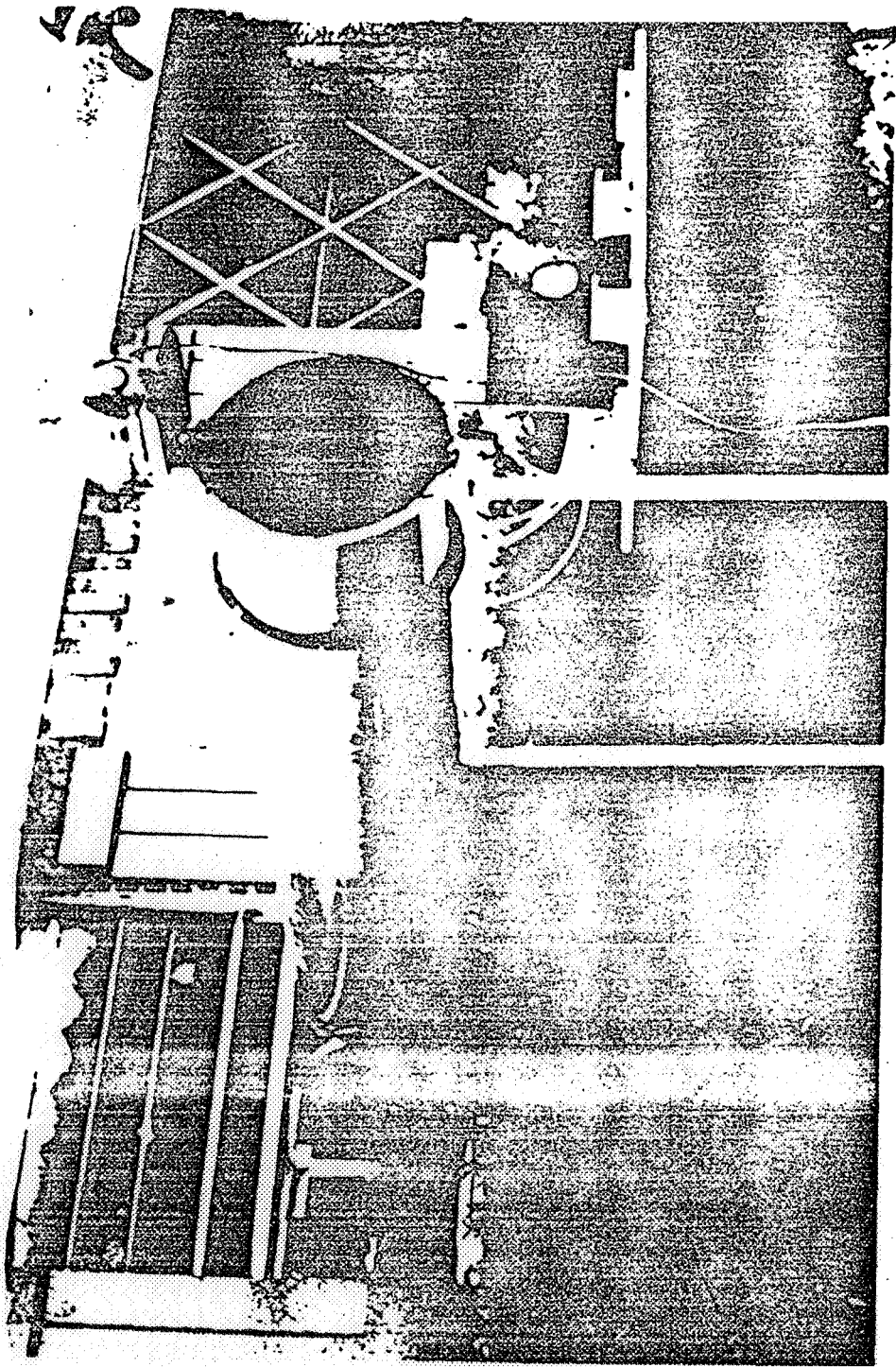

FIGURE D-1. TEXAS POWER & LIGHT TESTING DEVICE

TECHNIQUES FOR CONTROL OF AIR INFILTRATION IN BUILDINGS
(Johns-Manville)

Equipment

- *Window Blower Unit (see Pages 103 to 107).
- *Magnahelic Gauge Series 2000, Calibrated at 0 to 0.50 inches of water, Dwyer Instruments.
- *Inclined Manometer Model 125 AV, Calibrated at 0 to 1.0 inches of water, Dwyer Instruments.
- *Rubber Tubing for Gauges.
- *Duct Tape.
- *Assorted Boards.

Method

Mount the blower unit in a convenient window opening. Block off the space around the unit with assorted boards and duct tape so that no leakage will occur. Connect the Magnahelic Gauge to read pressure difference across the wall. Connect the Inclined Manometer to the pitot tube of the blower unit. Plug the fan motor into a 110 to 120 volt outlet, start the motor, and adjust speed with the rheostat to obtain the desired vacuum reading on the Magnahelic (0.3-inch to detect leaks, 0.2-inch for the Swedish standard, and 0.1-inch for measurement against the standard recommended in this report).

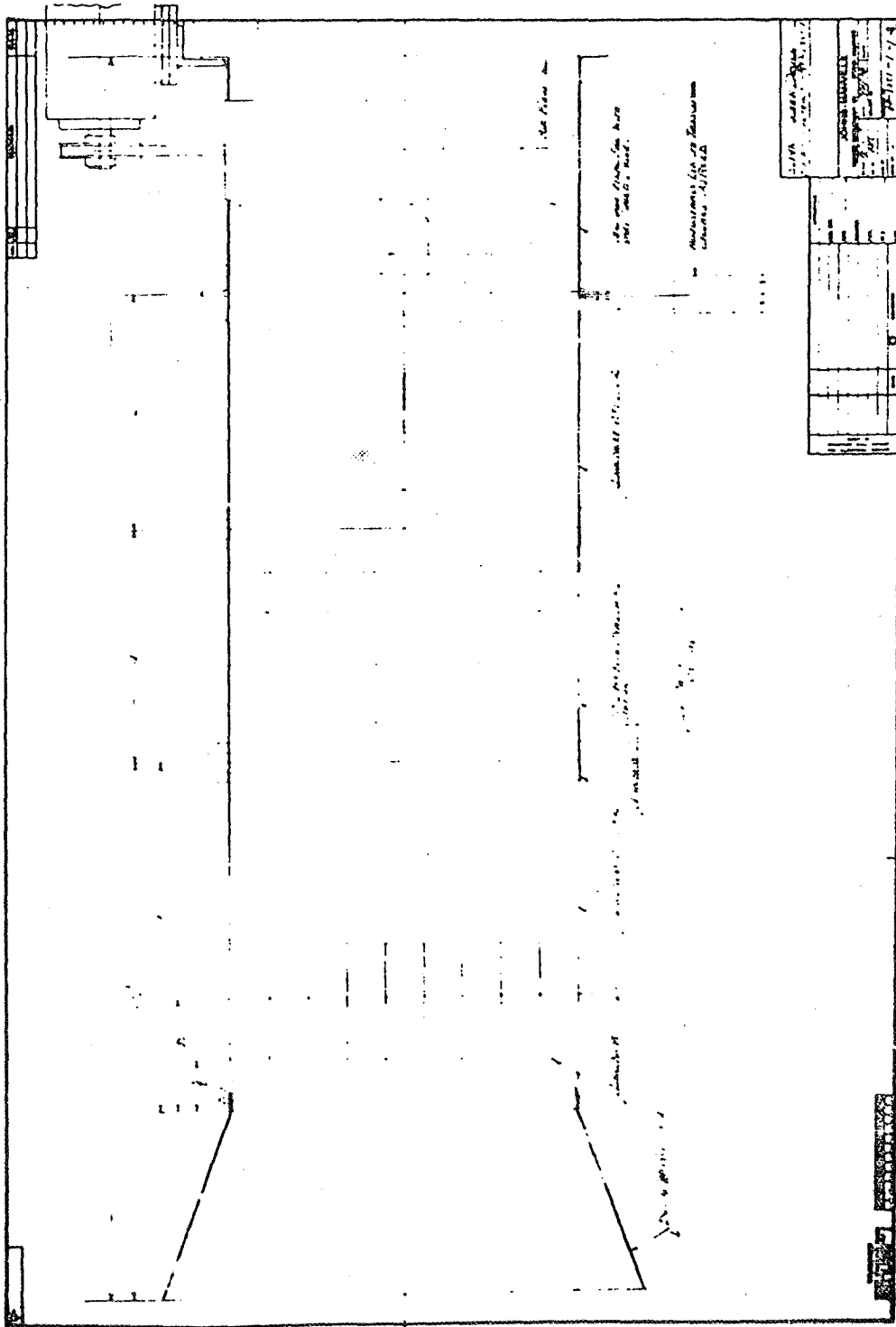

DATE	APR 19 1914
BY	C. A. REED
FOR	MANUFACTURING CO. OF KANSAS
PROJECT	...
...	...

...	...
...	...
...	...
...	...
...	...

...	...
...	...
...	...
...	...

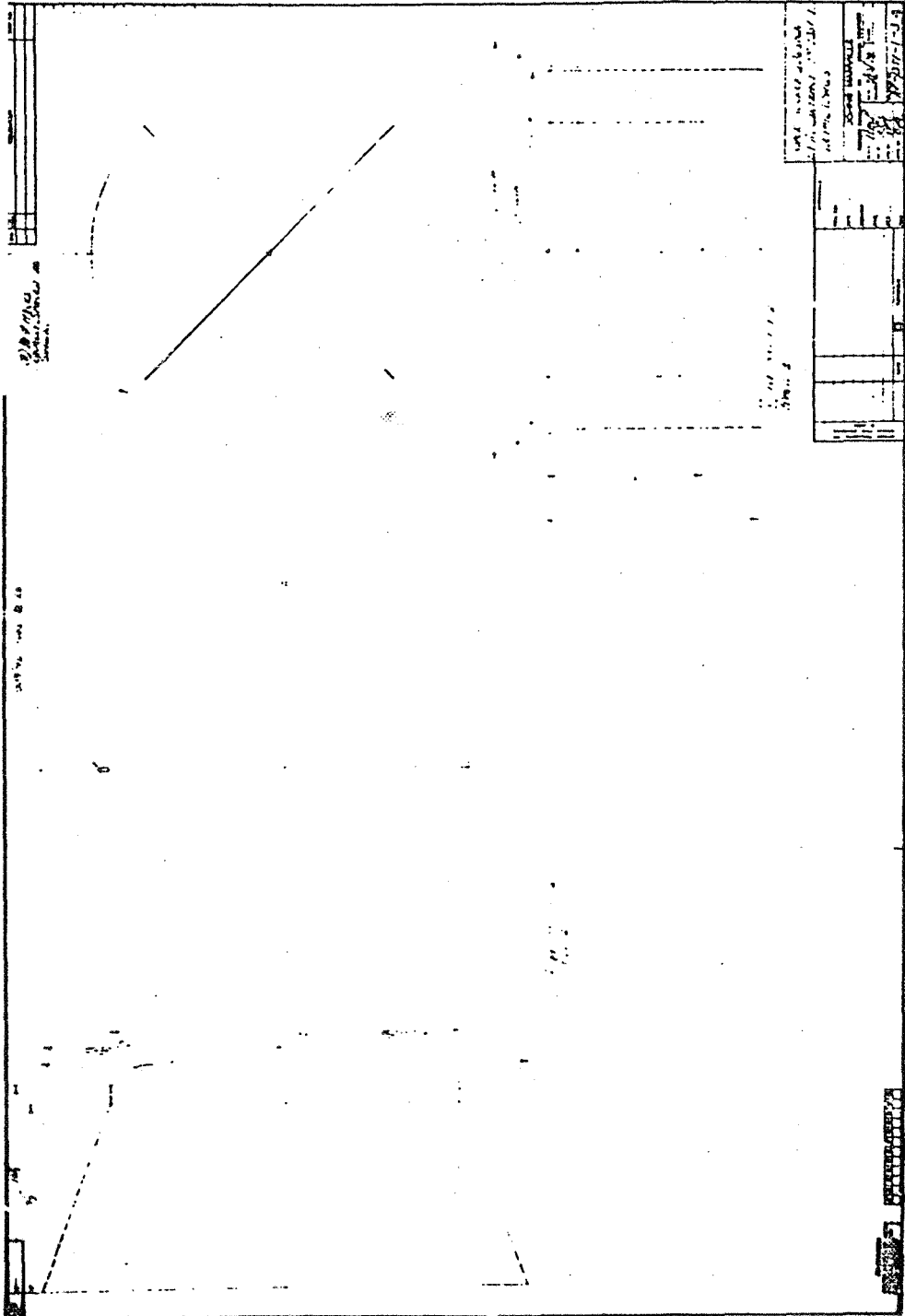

1. 1/4" = 1'-0" (Scale)
 2. 1/4" = 1'-0" (Scale)
 3. 1/4" = 1'-0" (Scale)
 4. 1/4" = 1'-0" (Scale)

NO.	DESCRIPTION	QUANTITY	UNIT
1	CONCRETE		
2	STEEL		
3	BRICK		
4	MORTAR		
5	PAINT		
6	GLASS		
7	DOORS		
8	WINDOWS		
9	ROOFING		
10	PLUMBING		
11	ELECTRICAL		
12	MECHANICAL		
13	INTERIORS		
14	EXTERIORS		
15	LANDSCAPE		

1. 1/4" = 1'-0" (Scale)
 2. 1/4" = 1'-0" (Scale)

1. 1/4" = 1'-0" (Scale)
 2. 1/4" = 1'-0" (Scale)

1. 1/4" = 1'-0" (Scale)
 2. 1/4" = 1'-0" (Scale)

1. 1/4" = 1'-0" (Scale)
 2. 1/4" = 1'-0" (Scale)

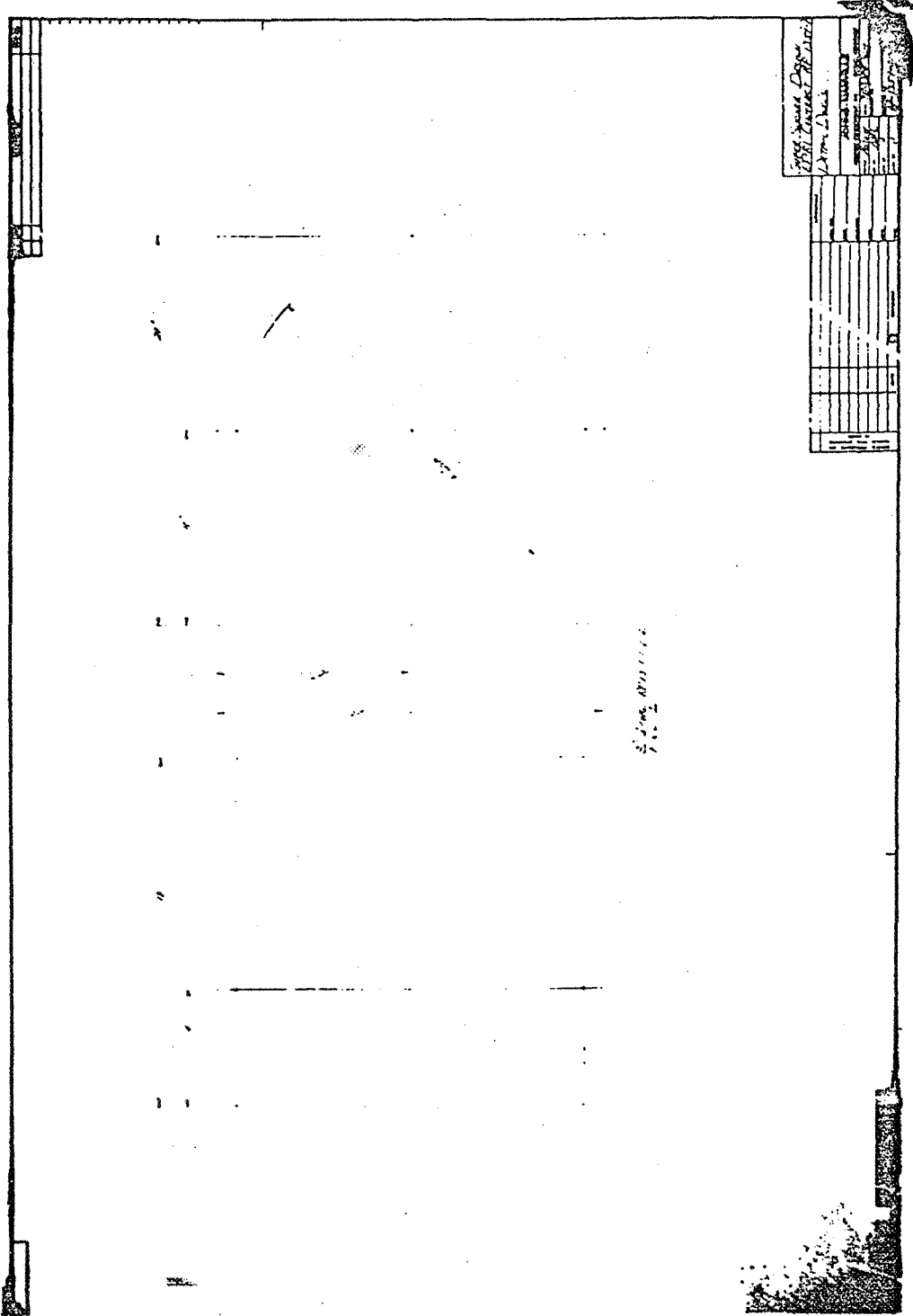

1954 Year Book	
Xmas Club	
1	
2	
3	
4	
5	
6	
7	
8	
9	
10	
11	
12	
13	
14	
15	
16	
17	
18	
19	
20	
21	
22	
23	
24	
25	
26	
27	
28	
29	
30	
31	
32	
33	
34	
35	
36	
37	
38	
39	
40	
41	
42	
43	
44	
45	
46	
47	
48	
49	
50	
51	
52	
53	
54	
55	
56	
57	
58	
59	
60	
61	
62	
63	
64	
65	
66	
67	
68	
69	
70	
71	
72	
73	
74	
75	
76	
77	
78	
79	
80	
81	
82	
83	
84	
85	
86	
87	
88	
89	
90	
91	
92	
93	
94	
95	
96	
97	
98	
99	
100	

3/10/54

