

# NBS TECHNICAL NOTE 992

U.S. DEPARTMENT OF COMMERCE / National Bureau of Standards

## An Investigation of Air- Infiltration Characteristics and Mechanisms for a Townhouse

## NATIONAL BUREAU OF STANDARDS

The National Bureau of Standards<sup>1</sup> was established by an act of Congress March 3, 1901. The Bureau's overall goal is to strengthen and advance the Nation's science and technology and facilitate their effective application for public benefit. To this end, the Bureau conducts research and provides: (1) a basis for the Nation's physical measurement system, (2) scientific and technological services for industry and government, (3) a technical basis for equity in trade, and (4) technical services to promote public safety. The Bureau's technical work is performed by the National Measurement Laboratory, the National Engineering Laboratory, and the Institute for Computer Sciences and Technology.

**THE NATIONAL MEASUREMENT LABORATORY** provides the national system of physical and chemical and materials measurement; coordinates the system with measurement systems of other nations and furnishes essential services leading to accurate and uniform physical and chemical measurements throughout the Nation's scientific community, industry, and commerce; conducts research in the basic and applied sciences of measurement, standards, and data processing; disseminates measurement information through commerce, educational institutions, and Government agencies; provides technical services to other Government Agencies; develops, produces, and distributes Standard Reference Materials; and provides calibration services. The Laboratory consists of the following centers:

Absolute Physical Quantities<sup>2</sup> — Radiation Research — Thermodynamics and Molecular Science — Analytical Chemistry — Materials Science.

**THE NATIONAL ENGINEERING LABORATORY** provides technology and technical services to users in the public and private sectors to address national needs and to solve national problems in the public interest; conducts research in engineering and applied science in support of objectives in these efforts; builds and maintains competence in the necessary disciplines required to carry out this research and technical service; develops engineering data and measurement capabilities; provides engineering measurement traceability services; develops test methods and proposes engineering standards and code changes; develops and proposes new engineering practices; and develops and improves mechanisms to transfer results of its research to the ultimate user. The Laboratory consists of the following centers:

Applied Mathematics — Electronics and Electrical Engineering<sup>2</sup> — Mechanical Engineering and Process Technology<sup>2</sup> — Building Technology — Fire Research — Consumer Product Technology — Field Methods.

**THE INSTITUTE FOR COMPUTER SCIENCES AND TECHNOLOGY** conducts research and provides scientific and technical services to aid Federal Agencies in the selection, acquisition, application, and use of computer technology to improve effectiveness and economy in Government operations in accordance with Public Law 89-306 (40 U.S.C. 759), relevant Executive Orders, and other directives; carries out this mission by managing the Federal Information Processing Standards Program, developing Federal ADP standards guidelines, and managing Federal participation in ADP voluntary standardization activities; provides scientific and technological advisory services and assistance to Federal Agencies; and provides the technical foundation for computer-related policies of the Federal Government. The Institute consists of the following divisions:

Systems and Software — Computer Systems Engineering — Information Technology.

<sup>1</sup>Headquarters and Laboratories at Gaithersburg, Maryland, unless otherwise noted; mailing address Washington, D.C. 20234.

<sup>2</sup>Some divisions within the center are located at Boulder, Colorado, 80303.

# An Investigation of Air-Infiltration Characteristics and Mechanisms for a Townhouse

---

S. J. Treado, D. M. Burch, and  
C. M. Hunt

Center for Building Technology  
National Engineering Laboratory  
National Bureau of Standards  
Washington, D.C. 20234

Sponsored by

Naval Facilities Engineering Command  
U.S. Navy  
Washington, D.C. 20390

Directorate of Civil Engineering  
U.S. Air Force  
Washington, D.C. 20330 and

Office of Chief of Engineers  
U.S. Army  
Washington, D.C. 20314



---

U.S. DEPARTMENT OF COMMERCE, Juanita M. Kreps, Secretary

Jordan J. Baruch, Assistant Secretary for Science and Technology

NATIONAL BUREAU OF STANDARDS, Ernest Ambler, Director

Issued August 1979

**National Bureau of Standards Technical Note 992**

Nat. Bur. Stand. (U.S.), Tech. Note 992, 36 pages (Aug. 1979)

CODEN: NBTNAE

U.S. GOVERNMENT PRINTING OFFICE  
WASHINGTON: 1979

---

For sale by the Superintendent of Documents, U.S. Government Printing Office, Washington, D.C. 20402

Stock No. 003-003-                      Price \$

(Add 25 percent additional for other than U.S. mailing)

AN INVESTIGATION OF AIR-INFILTRATION CHARACTERISTICS AND  
MECHANISMS FOR A TOWNHOUSE

S. J. Treado  
D. M. Burch  
C. M. Hunt

ABSTRACT

Air infiltration measurements using a tracer-gas technique and the pressurization technique were performed on a three-bedroom townhouse having a gas-fired, forced-air furnace system, in order to quantify the amount of air infiltration due to various mechanisms. These mechanisms include combustion and draft-diverter air requirements, air leakage from supply-air ducts, and air leakage through the solid parts of the building envelope as well as air leakage through cracks around windows and doors. A thermographic survey was also performed in conjunction with pressurization of the structure, in an attempt to identify specific leaks. An apparatus for measuring the air permeability of building materials was used to analyze the significance of air permeation through solid building elements. Based on the findings of the study, general guidelines are presented for reducing air infiltration in residences.

Key Words: Air infiltration, residential; air permeability of houses; energy conservation; pressurization technique; tracer-gas technique.

## TABLE OF CONTENTS

	PAGE
ABSTRACT . . . . .	iii
1. INTRODUCTION . . . . .	1
2. DESCRIPTION OF THE TEST HOUSE. . . . .	2
3. INSTRUMENTATION AND MEASUREMENT TECHNIQUE. . . . .	5
4. RESULTS AND ANALYSIS . . . . .	6
5. THERMOGRAPHIC SURVEY . . . . .	13
6. CONCLUSIONS AND RECOMMENDATIONS. . . . .	14
REFERENCES . . . . .	21
ACKNOWLEDGMENTS. . . . .	21
APPENDIX. AIR PERMEABILITY THROUGH BUILDING MATERIALS . .	22
NOMENCLATURE . . . . .	30
SI CONVERSION CHART . . . . .	31

## 1. INTRODUCTION

This project was carried out under the sponsorship of the Tri-Services Committee to provide technical information that could be used in future energy-conservation programs for existing buildings.

Air infiltration rates in residences characteristically range between 1/2 to 1-1/2 air changes per hour under typical winter conditions, and they can account for as much as 1/3 of the heating energy requirement. It should be possible to reduce air-infiltration rates for residences to 1/4 air change per hour without degrading the indoor air quality or comfort conditions, providing there is no unusually large emission or release of contaminants or moisture indoors. A minimum fresh air supply of 5 cfm per person is recommended by ASHRAE, a figure which corresponds to an infiltration rate of 1/8 air change per hour for a family of four in an average size (10,000 ft<sup>3</sup>) house.

Recent studies [1,2] have shown that the use of conventional measures (such as caulking and weatherstripping) to seal air leakage paths around windows and doors does not always produce significant reductions in the overall air-leakage rate. These results suggest that significant amounts of air leakage occur by way of other mechanisms such as duct leaks, combustion and draft-diverter air requirements, and air leakage through the walls, ceiling, and floor. Additional air leakage will occur when the bathroom or kitchen exhaust fans are operated. These other mechanisms are discussed in the following pages.

The seams where supply air duct sections of an air-distribution system are joined often leak small quantities of air when the heating plant operates. This may cause a small negative pressure to be imposed on portions of the living space of a residence, which in turn induces additional air infiltration.

When fuel-fired furnaces are located within the conditioned space of a residence, they often draw their combustion and draft-diverter air directly from the living space. Again, this imposes a negative pressure on the conditioned space and additional outside air is drawn into the conditioned space when the furnace operates.

In a recent study by the Canadian National Research Council [3], the pressurization technique was used to investigate the amount of air leakage occurring through the various components of the exterior envelopes of six residences. Significant amounts of air leakage were shown to occur through the walls and ceiling. In another study [4], the use of low-permeability polystyrene sheathing instead of wood-fiber sheathing on a residence produced a 29% reduction in the overall air-infiltration rate. As in the case of the previous study, these results suggest that air leakage occurs through solid building components. From these studies, it was not clear whether the air leakage through the solid elements of the buildings was due to air permeation through the building materials (similar to flow through porous media) or due

to fluid flow through hair-line cracks in building materials. In treating and reducing air infiltration in residences, an understanding of the nature of the air penetration process is necessary.

The objective of the present study was to experimentally investigate the amount of air infiltration occurring due to various mechanisms. Using a two-story townhouse as a test house, air pressurization and tracer-gas measurements were performed to quantify the amount of air infiltration attributable to duct leakage, combustion and draft-diverter air requirements, leakage around doors, windows, and electrical outlets, and leakage through other pathways in the walls and the ceiling. The study is described herein.

## 2. DESCRIPTION OF TEST HOUSE

The test house, built in 1970, was an end-unit two-story townhouse having a slab-on-grade floor. The floor area of the living space was approximately 1,212 ft<sup>2</sup>. A photograph and floor plan of the test house are given in Figures 1 and 2, respectively.

The walls of the test house were of nominal 2 x 4 inch wood-frame construction with full thickness of glass-fiber blanket insulation placed in the wall cavities. As shown in Figure 1, brick veneer covered a portion of the walls. The remaining upper portion of the side and rear walls was covered with aluminum siding. Five and one-half inches of loose-fill glass-fiber insulation were installed over the second-floor ceiling. Construction details of the walls and ceiling are given in Table 1. The inside wall surfaces consisted of gypsum board, with the exception of one exterior wall of the family room which was covered with wood paneling.

Table 1. Description of Exterior Building Components  
(Inside-to-Outside)

### WALL

1/2-inch	gypsum board
2 x 4	wood studs (with R-11 glass-fiber blanket insulation with asphalt-impregnated kraft paper vapor barrier)
1/2-inch	asphalt-impregnated wood-fiber sheathing brick veneer or aluminum siding

### CEILING

1/2-inch	gypsum board
2 x 6	joists (with 5-1/2 inches of loose-fill glass-fiber insulation)





Figure 1. Photograph of the test house.

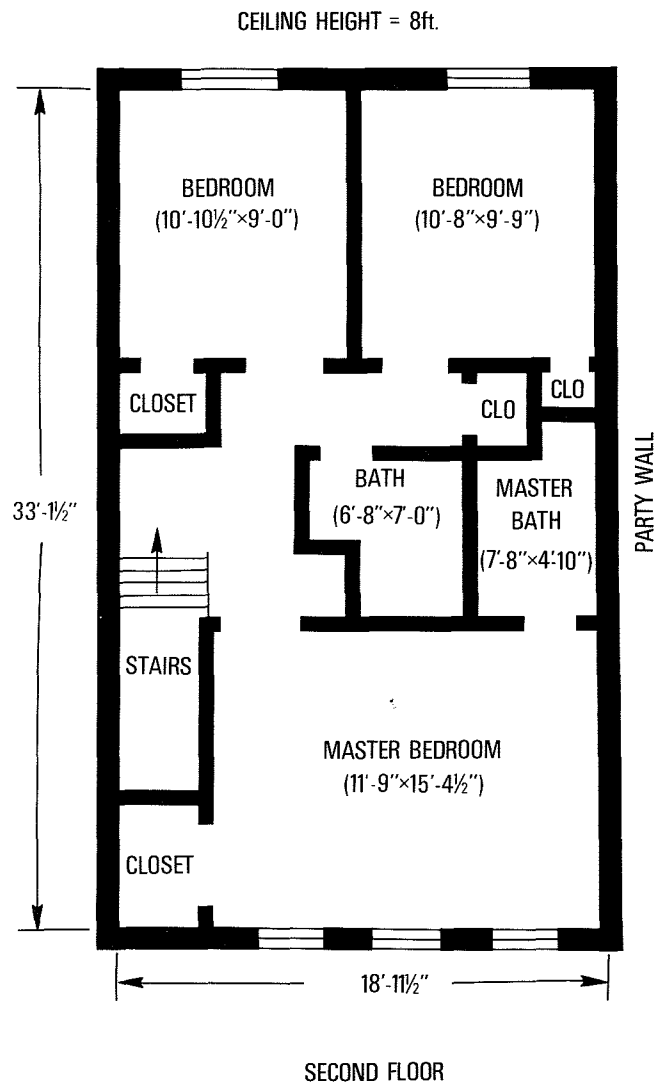
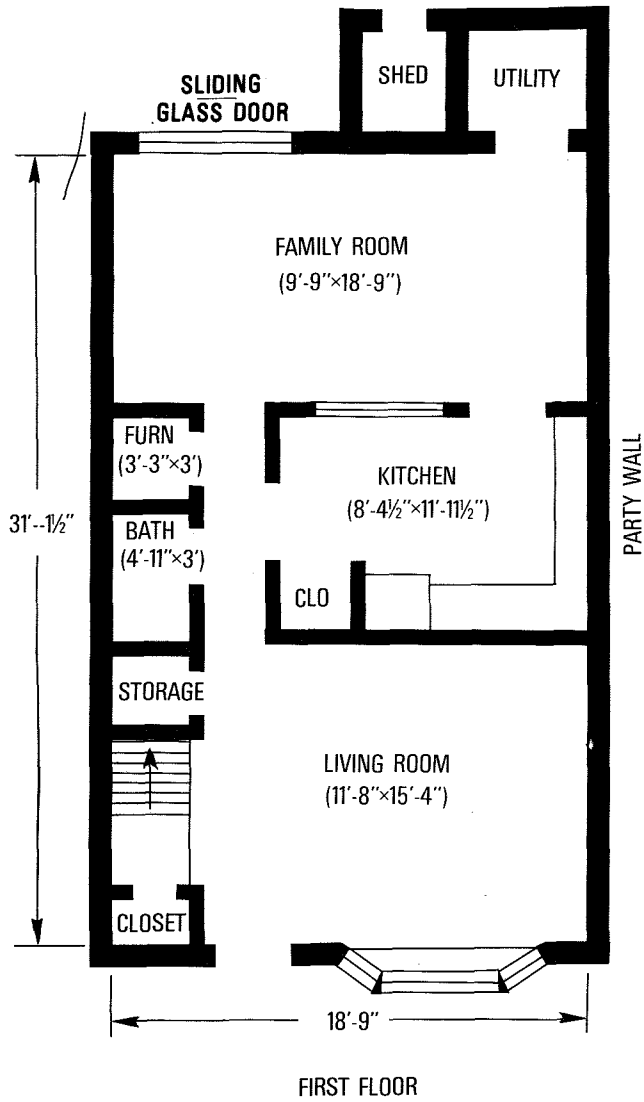

Figure 2. Floor plan of the test house.

The window systems were single-pane, double-hung wood-sash windows with screens, except for the bay window. The window area was 127 ft<sup>2</sup> or approximately 10% of the floor area, which is representative of residential construction. The windows and doors were equipped with good weatherstripping and appeared to be of reasonably tight construction.

The heating plant consisted of a gas-fired forced-air furnace having a rated input capacity of 90,000 Btu/h. The heating plant was located in a utility closet on the first floor of the test house, as indicated in Figure 2. Combustion and draft-diverter air were drawn from the living space by way of a louvered ventilation opening in the door of the utility closet. Supply-air ducts passed through interior partition walls. No supply-air ducts were located in the attic. Each floor was serviced by a single return register.

The front of the test house had a northwestern exposure and faced an opposite row of townhouses, while the rear was partially sheltered by a small hill and several evergreen trees.

### 3. INSTRUMENTATION AND MEASUREMENT TECHNIQUE

Air-infiltration rates under natural conditions were measured using a tracer-gas technique. For these measurements, a small quantity of sulfur hexafluoride (SF<sub>6</sub>) gas (approximately 4 cc) was introduced into the conditioned space of the test house by using a hypodermic syringe at the common air return of the heating plant. When the tracer gas was injected, the blower of the heating plant was operated for approximately 10 minutes in order to produce a uniform distribution of tracer gas throughout the house. The concentration of SF<sub>6</sub> within the conditioned space was monitored by taking periodic air samples at a supply air register when the blower of the heating plant operated. The concentration of SF<sub>6</sub> in air samples was measured using a semi-automated sampling system and a gas chromatograph equipped with an electron capture detector [5].

The decay rate of the tracer gas was treated as a first-order exponential process expressed by the equation:

$$\frac{dc}{dt} = -\frac{\dot{v}}{V} c \quad (1)$$

where  $\dot{v}$  = rate at which air enters or leaves the enclosure, ft<sup>3</sup>/h  
V = volume of the enclosure, ft<sup>3</sup>  
c = concentration of tracer gas at time t.

Solving eq. (1) yields

$$c = c_0 e^{-\frac{\dot{v}}{V} \cdot t} \quad (2)$$

or

$$I = \frac{\dot{v}}{V} = - \frac{1}{t} \cdot \log_e \left( \frac{c}{c_0} \right) \quad (3)$$

Here I is the number of volume changes per hour, and  $c_0$  is the initial concentration of tracer gas.

The natural logarithm of the relative concentration ( $c/c_0$ ) was plotted as a function of time and the air change rate (I) was determined from the negative slope of a best-fit straight line passing through the data points.

Combustion and draft-diverter air intake was measured by attaching a 1-foot long duct extension to the louvered opening of the utility closet door and sealing the remainder of the opening. The air speed was measured at various subareas of the duct using a hot-wire anemometer. The total volume of air flow through the duct was determined by summing the measured flows through the subareas. The air-delivery rate of the furnace blower was measured in a similar fashion, at the return registers located in the corner of the family room and in the upstairs hall.

The air tightness of various parts of the exterior envelope of the test house was determined using the pressurization technique. For this technique, a centrifugal blower was mounted on a sheet of plywood that was installed so as to replace one half of a sliding glass door at the rear of the test house. The maximum air-delivery rate of the blower was approximately 1860 ft<sup>3</sup>/min, as installed in this test configuration. Outdoor air, upon passing through the blower, passed through an air-flow measuring device, after which it was delivered to the conditioned space of the test house. The air-flow measuring device consisted of a honeycomb air straightener, an array of pitot tubes for measuring the total pressure, and an another array of pressure ports for measuring the static pressure. The pressure difference between these arrays, which is the velocity head, was measured with an inclined manometer having a resolution of 0.003 inches of water column. The air intake of the blower was equipped with a damper for varying the air-delivery rate.

The operation of the blower pressurized the interior of the test house and caused an inside-to-outside pressure gradient to be developed. This pressure difference was measured using two equal length flexible tubes (one positioned at the inside surface of the building envelope, the other positioned at a corresponding location at the outside surface) connected to an inclined manometer or an electronic pressure transducer.

#### 4. RESULTS AND ANALYSIS

Sets of consecutive air-infiltration measurements were performed using the tracer-gas technique to investigate the increase in the rate of air

infiltration due to operation of the furnace blower. During the blower-on measurements, the furnace blower was operated continuously. For the blower-off measurements, the furnace blower was operated for ten minutes after injection of tracer-gas to provide uniform mixing. Then the blower was turned off for 60 minutes, after which the fan was turned on again for ten minutes to provide uniform mixing prior to sampling the decay in tracer-gas concentration.

A comparison between infiltration rates for cases with and without blower operation is given in Table 2. It can be seen that blower operation caused an average increase in the rate of air infiltration,  $\Delta I$ , of approximately 0.11 air changes per hour or a 20% increase. The principle driving forces for air infiltration, the inside-to-outside temperature difference and wind speed, are seen to be approximately equivalent for both the blower on and off measurements for each of the sets of measurements. This increase in air infiltration was principally attributed to air leakage at the seams of supply air ducts located in interior wall cavities. The wall cavities were separated from the attic by wood plates which ran horizontally along the top of the wall. These data were obtained during both winter and summer measurements.

Table 2. The Effect of Blower Operation on the Rate of Air Infiltration

$T_i - T_o$ °F	Wind Speed mph	Furnace Blower Operation	$I$ $h^{-1}$	$\Delta I$ $h^{-1}$
-5	2.5	ON	0.38	0.13
-5	2.5	OFF	0.25	0.06
-5	2.5	ON	0.31	
-6.4	2.0	ON	0.29	0.16
-6.4	2.0	OFF	0.13	0.11
-6.4	2.0	ON	0.24	0.09
-6.4	2.0	OFF	0.15	
39.5	3.0	ON	0.62	0.12
41.7	2.1	OFF	0.50	

where  $T_i$  = indoor air temperature, °F.       $Av.\Delta I = 0.11$   
 $T_o$  = outdoor air temperature, °F.

Under winter conditions assume average  $I = 0.56 h^{-1}$  (obtained by averaging the fan-on and fan-off values measured under the 40°F temperature differential condition)

$$\frac{\Delta I}{I} = \frac{.11}{.56} = 20\% \text{ increase}$$

Based on conservation of mass considerations, if we assume that air which leaks from supply air ducts and furnace jacket is lost from the conditioned space, then an equal amount of replacement air must be drawn into the conditioned space through the exterior building envelope, or

$$\frac{\Delta I}{60} \cdot V = f \cdot \dot{u} \quad (4)$$

where  $\Delta I$  = induced air infiltration rate,  $h^{-1}$   
 $V$  = volume of the enclosure,  $ft^3$   
 $f$  = fraction of the air delivered by the furnace blower that is lost by way of duct leaks  
 $\dot{u}$  = air-delivery rate of the blower,  $ft^3/min$ .

For this particular test house under the conditions tested,  $V = 9369 ft^3$ ,  $\Delta I = 0.11 h^{-1}$  and  $\dot{u} = 769 ft^3/min$ . From eq. (4), the fraction of the air delivered by the furnace blower that is lost by way of duct leaks is found to be 2.2%. These results indicate that duct leaks which appear to be of minor significance may substantially increase the rate of air infiltration for a house.

The combustion and draft-diverter air requirements were measured and found to be  $49 ft^3/min$ . This corresponds to an induced air infiltration rate of 0.31 air changes per hour.

Most natural gases are comprised predominantly of methane. Neglecting the presence of other hydrocarbons, the chemical equation for the complete combustion of methane is:

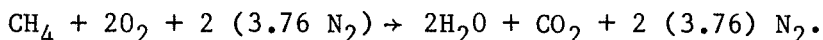

The burning of 1 mole ( $1 ft^3$ ) of methane is seen to require 9.52 moles ( $9.52 ft^3$ ) of air. Furnaces typically require 40% excess air in order to achieve complete combustion. Therefore, a furnace typically requires  $13.3 ft^3$  of combustion air for every cubic foot of gas burned. The draft-diverter air requirement will generally be 40% more than the combustion air requirement, or  $1 ft^3$  of gas burned requires  $18.7 ft^3$  of draft-diverter air. Therefore a total of  $32 ft^3$  of air is required for every cubic foot of gas burned.

When the furnace of this test house operated, it was rated to consume gas at  $90 ft^3/h$ . Based on the foregoing considerations, the combustion and draft-diverter air requirements are estimated to be  $48 ft^3/min$ , compared to a measured value of  $49 ft^3/min$ .

The relative air tightness of various parts of the exterior envelope of the test house was determined using the pressurization technique. The experimental procedure was to pressurize the test house to approximately 0.1 inches of water, using a centrifugal blower. A stagnation pressure of approximately 0.1 inches of water will result when a 14-mph wind is

decelerated by a wall. Various parts of the exterior envelope of the test house were consecutively sealed using sheets of polyethylene film attached with duct tape to the inside surface. During each phase of these measurements, the air-delivery rate of the blower was adjusted so that the inside-to-outside pressure difference remained constant. Reductions in flow rates achieved by sealing various parts of the exterior envelope are given in Table 3. In cases where only a fraction of the total area of a component was sealed, the corresponding reduction that would have occurred if the entire interior surface of that component had been sealed was estimated by multiplying the observed reduction in flow rate by the ratio of total surface area of the component to the surface area sealed. If 50% of the ceiling was sealed, the measured reduction would be doubled to obtain an estimate of the total reduction expected had 100% of the ceiling been sealed.

When windows were sealed, the sealing included the window frames. When exterior walls containing windows were sealed, the polyethylene sheet was stretched across the window and the window area was subtracted from the total area sealed, leaving the actual wall area sealed. Electrical outlets were sealed for measurement and left sealed, and no ceiling light fixtures were present. Since the windows, doors and electrical outlets were left sealed during most of the additional testing, the total prorated reduction percentage values are adjusted to compensate for the reduced available leakage area.

Air flow through cracks in buildings can be represented by the following relation [6,7]:

$$Q = a(\Delta p)^n \tag{5}$$

where  $Q$  = flow rate through crack,  $\text{ft}^3/\text{min}$

$a$  = flow coefficient

$\Delta p$  = pressure differential across crack, in  $\text{H}_2\text{O}$

$n$  = a parameter typically ranging between 0.6 and 0.8.

From this relation, it is seen that the rate of air flow does not vary linearly with the pressure differential. As a result, the measured reductions listed in Table 3 are not strictly comparable because the measurements were obtained at different inside-to-outside pressure differentials. However, analysis indicates that inaccuracies due to this factor have a small effect on the results and conclusions drawn from this table. An example is given below.

In order to adjust the air flow rates listed in Table 3 to a common inside-to-outside pressure difference, it would be necessary to know the flow rate relation for the individual leakage paths. Each leakage path may have different values of  $a$  and  $n$  from eq. (5). As a worst case example, examine the floor/wall interface component from Table 3.

Table 3. Reduction in Flow Rates Achieved by Sealing Various Parts of Exterior Envelope

Component	area sealed %	$\Delta P$ in. H <sub>2</sub> O	reduction (initial value) cfm	measured reduction for area sealed %	total prorated reduction over entire area %
Exterior Wall <sup>a</sup>	21	.12	105(1605)	6.5	27.9
Ceiling <sup>a</sup>	35	.12	80(1655)	4.8	12.3
Party Wall	30	.13	25(1630)	1.5	4.5
Windows and Doors	100	.110	75(1680)	4.5	4.5
Electrical outlets					
° Exterior walls	100	.065	52(1603)	3.2	3.1
° Party walls	100	.13	25(1805)	1.4	1.3
Floor/wall interface	25.5	.065	110(1860)	5.9	23.1
Unsealed air leakage paths such as wall/ceiling interface, or unaccounted-for areas					23.3

<sup>a</sup> Does not include wall/ceiling interface

Measurements of the leakage through this component were performed at  $\Delta p = 0.065$  in H<sub>2</sub>O. The initial flow rate was 1860 cfm and the reduction was found to be 110 cfm, for a reduction of 5.9%. The reduction in flow rate is equal to the leakage through the floor/wall interface.

From eq. (5)

$$Q_T = 1860 = a_T (.065)^{n_T}$$

$$Q_R = 110 = a_R (.065)^{n_R}$$

where

$Q_T$  = initial flow rate, cfm

$Q_R$  = reduction in flow rate, cfm

$a_T$  = total flow coefficient



$a_R$  = reduction flow coefficient

$n_T$  = initial exponent

$n_R$  = reduction exponent

In order to calculate flow rates which would occur at a different  $\Delta P$ , it would be necessary to know the values of  $n_T$  and  $n_R$ , which could be determined through a series of measurements at different  $\Delta p$  values.

If the values of  $n_T$  and  $n_R$  are the same, the percentage reduction would be the same at any  $\Delta P$ , and would be independent of  $n$ . If the values of  $n_T$  and  $n_R$  are different, the percentage reduction would be different at a different  $\Delta P$ . The magnitude of the difference between the measured percentage reduction value and the percentage reduction value which would occur at a different  $\Delta P$  would depend upon the difference between the value of  $n_T$  and  $n_R$ , and the amount of pressure difference adjustment. Larger pressure difference adjustments would cause larger differences between the percentage reduction values at the initial  $\Delta P$  and the percentage reduction values at the adjusted  $\Delta P$ . Larger differences between  $n_T$  and  $n_R$  would also increase the difference between percentage reduction values at different pressure differentials.

Since the values of  $n_T$  and  $n_R$  are not known in this case, it is possible that the percentage reduction which was measured at  $\Delta P = 0.065$  in  $H_2O$  would have been different at a different  $\Delta P$ . To estimate the possible magnitude of this effect, flow rates were calculated using various combinations of  $n$  values, ranging from 0.65 to 0.75. Adjusting the flow rates to a pressure differential of 0.12 in  $H_2O$  yields percentage reductions which are in agreement with measured values to within approximately 5.6% full scale (in this case  $23.1\% \pm 5.6\%$ ).

This example represents a worst case, as most of the measurements were made at pressure differentials of  $0.12 \pm .01$  in.  $H_2O$ . The only other measurement made at 0.065 in.  $H_2O$ , exterior wall electrical outlets, represents a total reduction of 3.1%, so error in its determination would have a small effect on the overall percentage reduction values.

From Table 3, it is seen that 40.2% of the air leakage observed during pressurization tests occurred through the exterior walls and the ceiling. Only 8.9% of the air leakage occurred through cracks around the windows, doors, and electrical outlets. It was hypothesized that air leakage through solid components of the building envelope could be due to permeation of air through building materials (similar to flow through a porous media). Air permeation rates through building materials similar to those comprising the envelope of the test house were measured in the laboratory (see appendix). These measurements showed that air permeation through solid building materials was insignificant compared

to the overall rate of air infiltration for the test house. It was concluded that air leakage through solid components of the building envelope occurred through joints and cracks where building materials come together.

Of particular interest is the amount of air infiltration that occurs as a result of the various mechanisms under typical conditions. The overall rate of air infiltration corresponding to a 50% duty cycle for the furnace blower was obtained by averaging the blower on and off data obtained during the coldest conditions listed in Table 2, yielding  $0.56 \text{ h}^{-1}$  or  $87.4 \text{ ft}^3/\text{min}$ . The values given in Table 2 were obtained when the furnace burner was off. The induced air-infiltration rate needed to satisfy combustion and draft-diverter air requirements was taken to be one half the figure of  $49 \text{ ft}^3/\text{min}$ , or  $24.5 \text{ ft}^3/\text{min}$ . Thus, the overall air-infiltration rate for the test house is equal to  $111.9 \text{ ft}^3/\text{min}$ , or  $0.717 \text{ h}^{-1}$ , under these conditions. Combustion and draft-diverter air accounts for 21.9% of the air leakage in this example. This contribution will vary with different climatic conditions and length of furnace cycle.

Similarly, operation of the furnace blower has been shown to produce an increase in air leakage amounting to 0.11 air changes per hour, or  $8.6 \text{ ft}^3/\text{min}$  for a 50% furnace duty cycle. In this example, that would account for 7.7% of the overall leakage. The remainder of the leakage will "flow through" the exterior envelope of the house, entering the house at some points and exiting at others.

For the case of air flow through various parts of the exterior envelope, the rates of natural air infiltration through various components were assumed to be proportional to corresponding reductions in flow rates observed during the pressurization tests. This assumption may not be representative of natural conditions as a large pressure differential of constant magnitude across the entire envelope of a residential structure may rarely, if ever, occur. A more typical situation would be that of high outdoor static pressure at a windward wall, low static pressure at a leeward wall, and positive inside pressure at the ceiling due to stack effect. However, the results presented here are believed to indicate potential leakage paths under natural conditions and identify areas which could be improved to reduce air infiltration. The results of this analysis are given in Table 4.

Table 4. Breakdown of Potential Air Leakage Paths Under Winter Conditions.

Assume Overall Infiltration Rate

$$I = 0.717 \text{ h}^{-1} \text{ (or } 111.9 \text{ ft}^3/\text{min)}$$

For a 50% Duty Cycle for Furnace

	<u>ft<sup>3</sup>/min.</u>	<u>%</u>
Operation of Furnace Blower	8.6	7.7
Combustion and Draft-Diverter Air	24.5	21.9
Total	<u>33.1</u>	<u>29.6</u>
<hr/>		
Leakage through Exterior Envelope	<u>ft<sup>3</sup>/min</u>	<u>%</u>
Total	<u>78.8</u>	<u>70.4</u>
Components:		
Exterior walls	22.0	19.7
Floor/wall interface	18.2	16.3
Ceiling of second story	9.7	8.7
Party wall	3.5	3.1
Cracks		
° Windows and doors	3.5	3.1
° Electrical outlets	3.5	3.1
Unsealed air leakage paths	18.4	16.4

## 5. THERMOGRAPHIC SURVEY

A thermographic survey of the structure was performed, in combination with operation of the pressurization fan, in an attempt to visually document some of the air-leakage paths. An infrared television system, which is sensitive to the total thermal radiation emitted and reflected from a surface, was utilized for this purpose. This system has been previously described [1] as well as the test procedure [8].

The testing method involved both interior and exterior scans of the structure, first under normal conditions and subsequently with the pressurization fan operating. Exterior scans were done with a positive inside pressure and any air leaks, if visible at all, were expected to be indicated by the appearance of warm spots. Interior scans were performed in combination with a depressurization of the house, with air leaks indicated by cold spots. By comparing the temperature patterns obtained before and after fan operation, any relative

changes could be attributed to air leakage. It should be noted that the absolute values of the surface temperatures were not compared, because without a reference, adjustment of the thermographic camera to identical absolute radiance temperature level was difficult due to the time interval separating the "before" and "after" comparisons. The use of color thermograms rather than gray-tone thermograms was seen to be of much value in enabling an accurate resetting of the absolute radiance temperature level to allow comparisons of the relative temperature profiles of the "before" and "after" thermograms. The absolute radiance temperature level was adjusted until the coldest spot was displayed with the color corresponding to the coldest temperature band.

### 5.1 Results of Thermographic Survey

For the exterior scan, thermograms were initially made under normal conditions (see Figure 3a). The rectangular object in the lower left is a piece of foam insulating board, the surface temperature of which would indicate the outside air temperature (29°F). The temperature spectrum from the coldest region (coded black) to the warmest region (coded yellow) is displayed at the bottom of each color thermogram. The total temperature band covers 9°F, so that the difference in temperature between adjacent colors is 0.9°F.

After the pressurization fan was turned on, shots were made every ten minutes for a period of one hour (see Figure 3b). Almost immediately a warm spot appeared on the aluminum siding covering the upper part of the second floor exterior end wall. Further examination found that located inside the warm spot was the upper portion of the furnace closet, which contained air ducts and vent pipes. This duct chase was nominally separated from the living space by drywall, but not sealed from the attic, and also separated from the first floor by the ceiling drywall.

From these factors, it was surmised that the air leakage path responsible for the warm spot is through duct leaks or leakage through the interior walls to the duct chase.

The interior scan was performed in a similar manner. No significant differences were observed that could be attributed to fan pressurization, with the exception of a slight effect near the floor-wall interface under a bay window (see Figure 4a, b). Several traditional leakage paths were documented, including the front door (no storm door) (Figure 5), closet corner (Figure 6), and window/corner (Figure 7). The hot air supply register appears very warm.

## 6. CONCLUSIONS AND RECOMMENDATIONS

This study showed that, when the furnace of the test house operated with a 50% duty cycle, approximately 30% of the overall rate of air infiltration for the test house was due to the operation of the blower

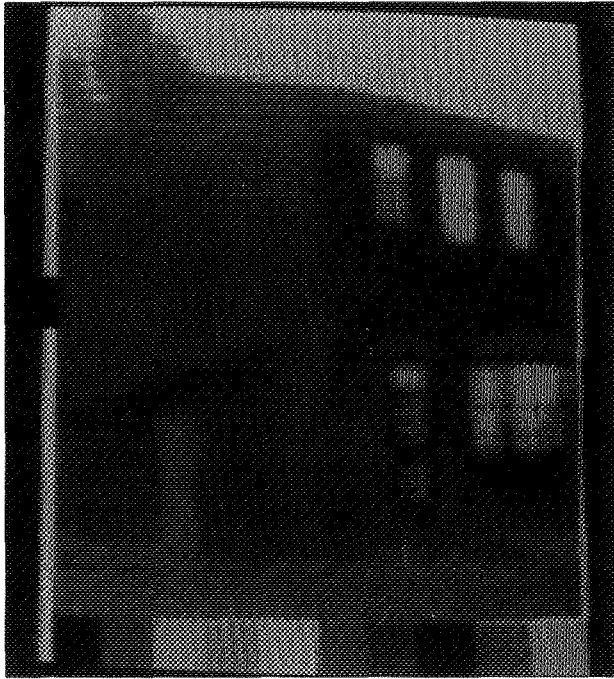

Figure 3a. Exterior thermographic scan under normal conditions.

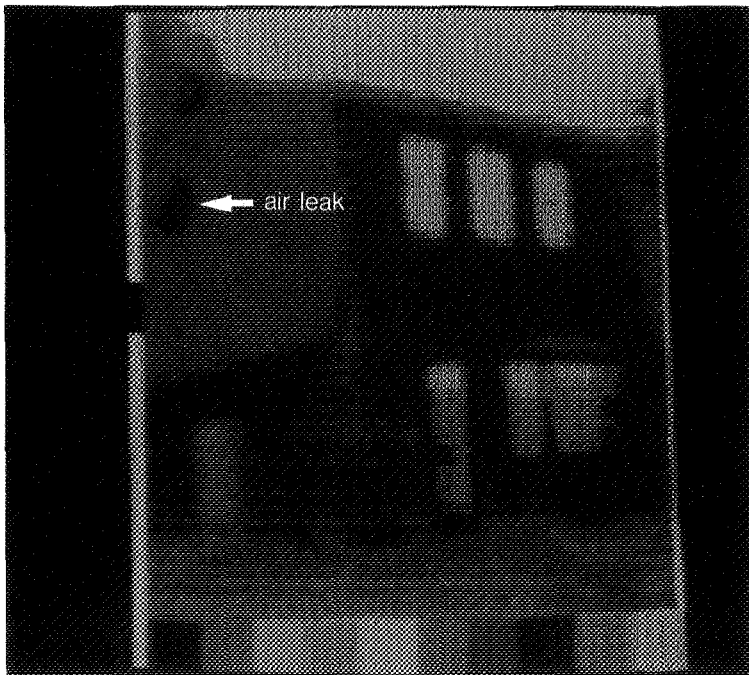

Figure 3b. Exterior thermographic scan while pressurized.



Figure 4a. Wall/floor interface under normal conditions.

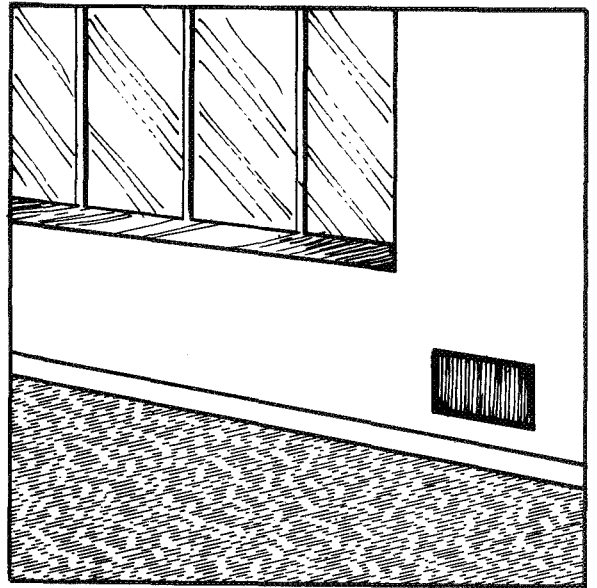

Figure 4b. Wall/floor interface while pressurized.

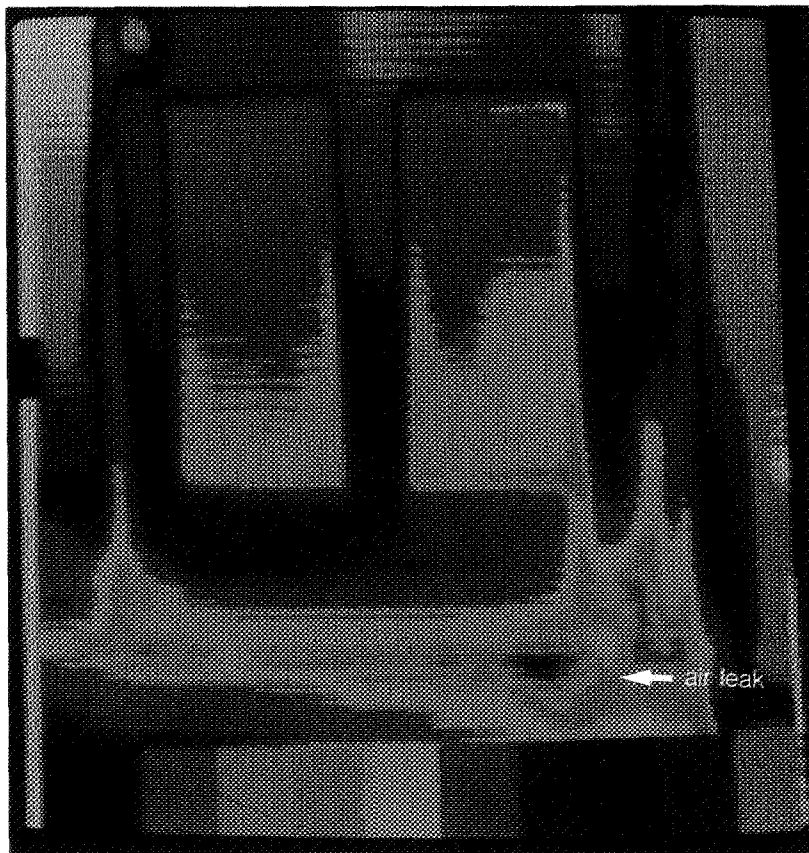
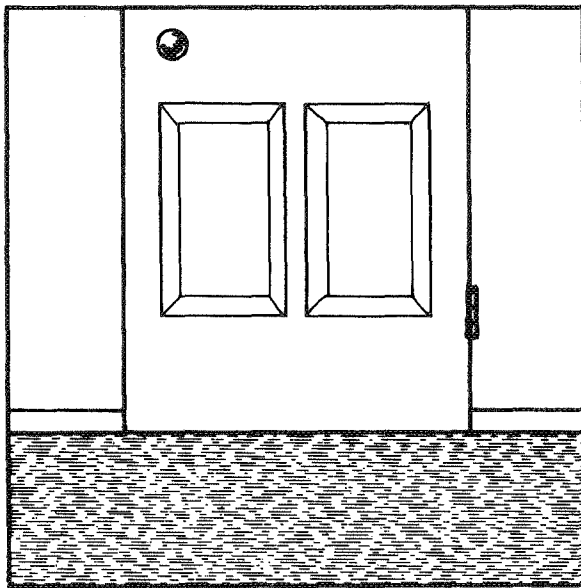

Figure 5. Front door while pressurized.

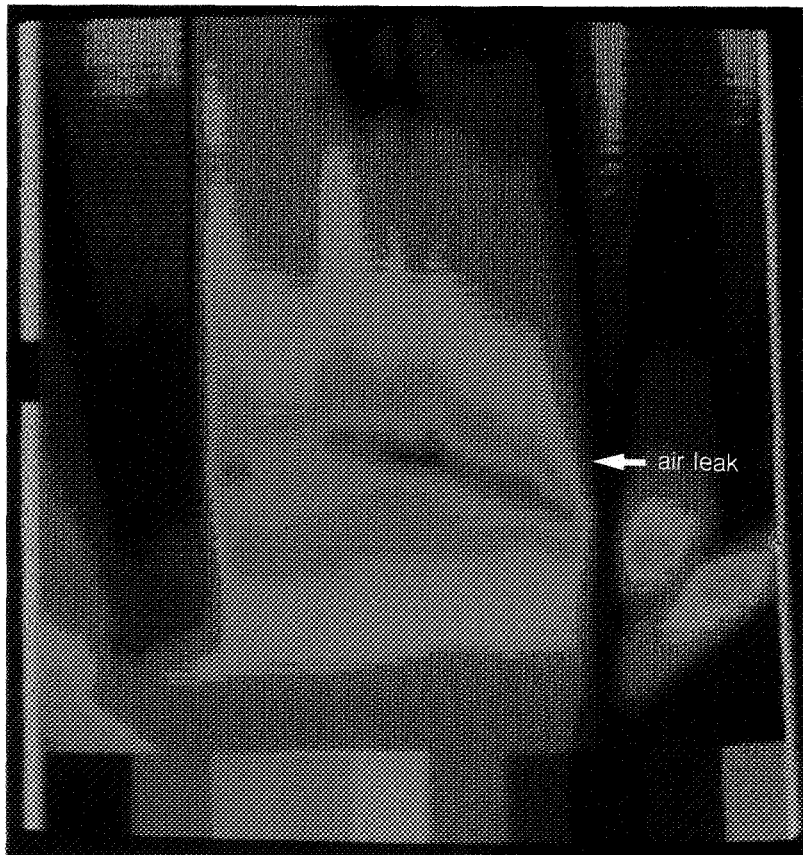
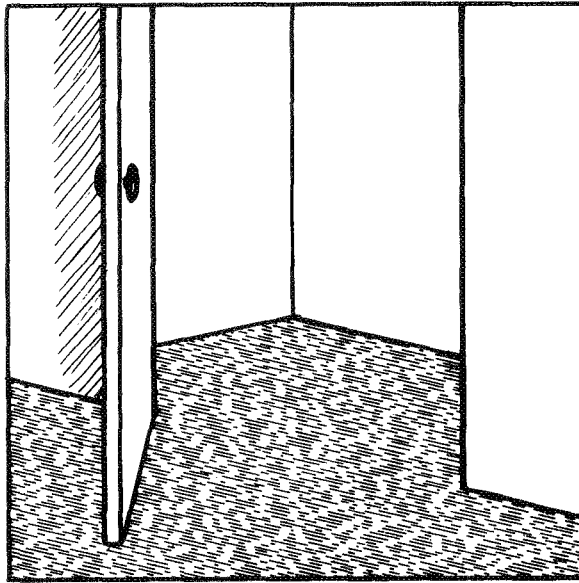

Figure 6. Closet corner while pressurized.



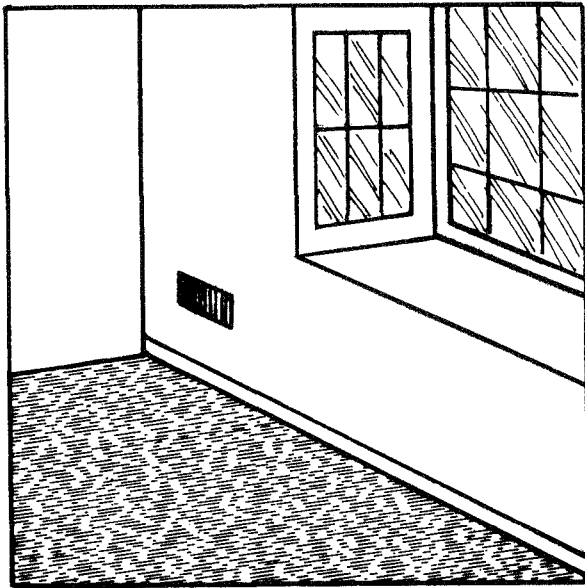

Figure 7. Window corner while pressurized.

and the burner of the furnace. Air leakage through the walls and ceiling accounted for 31% of the overall air-infiltration rate. A surprising finding was that air leakage through cracks around windows, doors, and electrical outlets accounted for only 6% of the overall air-infiltration rate. Separate air-permeability measurements performed on building materials similar to those of the test house showed that air leakage through solid elements of the test house was not due to air permeation. It was hypothesized that this leakage was due to air leakage through joints and cracks between building materials, such as baseboard cracks, etc.

Based on the results of this study, substantial reductions in the rate of air infiltration could be achieved by:

- Modifying the combustion closet so that required combustion and draft-diverter air are taken from the outdoor environment instead of the conditioned space of the house;
- Eliminating duct leaks. This may be accomplished by using a suitable duct sealant, either during construction or as a retrofit measure; and
- Eliminating air leakage through joints and cracks between building materials and where the building envelope is penetrated by service outlets of various types. At the time of construction, this may be accomplished by installing a continuous membrane of polyethylene between the wood framing and stud cavities and the interior dry wall.

If these measures had been carried out on this particular test house, the overall rate of air infiltration could have been reduced by more than 50%.

## REFERENCES

1. D. M. Burch and C. M. Hunt, Retrofitting an Existing Wood Frame Residence for Energy Conservation -- An Experimental Study, NBS Building Science Series 105, (1978).
2. B. A. Peavy, D. M. Burch, F. J. Powell, and C. M. Hunt, Comparison of Measured and Computer-Predicted Thermal Performance of a Four-Bedroom Wood-Frame Townhouse, NBS Building Science Series 57, (April, 1975).
3. G. T. Tamura, Measurement of Air Leakage Characteristics of House Enclosures, ASHRAE Transactions, Vol. 81, Part 1, pp. 202-211, (1975).
4. C. F. Sepsy, Energy Usage Comparisons of Identical, Non-Inhabited, Residential Homes with Two Types of Insulation and a Program Simulation of the Required Heating Loads, Environmental Control Group, Department of Mechanical Engineering, Ohio State Univ., Columbus, Ohio, (1978).
5. C. M. Hunt and S. J. Treado, A Prototype Semi-Automated System for Measuring Air Infiltration in Buildings Using Sulfur Hexafluoride as a Tracer Gas, NBS Technical Note 899, (March, 1976).
6. Larson, G. L., D. W. Nelson, and C. Braatz, Air Infiltration Through Various Types of Brick Wall Construction, ASHVE Trans. 35, (1929).
7. Larson, G. L., D. W. Nelson, and C. Braatz, Air Infiltration Through Various Types of Wood Frame Construction, ASHVE Trans. 36, (1930).
8. Kronvall, J., Testing of Houses for Air Leakage Using A Pressure Method, ASHRAE Trans. Vol 34, Part 1, (1978).

## ACKNOWLEDGMENTS

The authors wish to acknowledge the contributions of Marc LeMay, who constructed the permeameter and carried out the installation of instrumentation in the test house. The authors would also like to thank Mrs. Mary Reppert for her many editorial comments which substantially improved the quality of the manuscript.

APPENDIX

AIR PERMEABILITY THROUGH BUILDING MATERIALS

## AIR PERMEABILITY THROUGH BUILDING MATERIALS

### 1. Theory

Results of air-infiltration measurements performed on a three-bedroom townhouse indicate that substantial air infiltration occurs through the solid components of a building such as its walls, ceiling, etc. A possible explanation for this effect is that air may permeate directly through the material. Fluid flow through a porous medium is governed by Darcy's Law, or

$$Q_o = \frac{-k}{\mu} \cdot \frac{\partial P}{\partial x} \quad (1)$$

where  $Q_o$  = superficial flow rate per unit surface area, ft/sec  
 $k$  = permeability of porous medium, ft<sup>2</sup>  
 $\mu$  = dynamic viscosity of air, lbf·sec/ft<sup>2</sup>  
 $x$  = distance, ft  
 $P$  = pressure, lbf/ft<sup>2</sup>.

For the case of constant  $\mu$  and  $k$ , the foregoing equation can be integrated across a building component of thickness ( $L$ ) to yield:

$$Q_o = \frac{k}{\mu} \cdot \frac{\Delta P}{L} = \left(\frac{k}{\mu L}\right) \cdot \Delta P \quad (2)$$

Here  $\Delta P$  is the pressure difference across the building element. In the foregoing equation, we see that the air flow rate through a building component is directly proportional to the pressure difference across the component and the air permeance  $\left(\frac{k}{\mu L}\right)$  of the component.

Applying eq. (1) to a composite building component having  $n$  layers and making use of continuity relations at the adjoining boundaries, we obtain:

$$Q_o = \frac{\Delta P}{\left(\frac{\mu L}{k}\right)_1 + \left(\frac{\mu L}{k}\right)_2 + \dots + \left(\frac{\mu L}{k}\right)_n} \quad (3)$$

Here  $\Delta P$  is the pressure difference across the composite building component and  $\left(\frac{\mu L}{k}\right)_i$  is the resistance to air permeation of the  $i$ -th layer.

Taking the logarithm of eq. (2), we obtain:

$$\ln(Q_o) = -\ln \sum_{i=1}^N \left(\frac{\mu L}{k}\right)_i + \ln(\Delta P) \quad (4)$$

From this relation, we see that  $\ln(Q_o)$  is a linear function of  $\ln(\Delta P)$ . A plot of  $\ln(Q_o)$  versus  $\ln(\Delta P)$  yields a straight line of unity slope.

## 2. Description of Apparatus

A prototype device, called a permeameter, for measuring the air permeability ( $k$ ) of building materials in the laboratory was designed. A cross section of the apparatus is shown in Figure A-1. The device consists of a motor-driven syringe with variable speed control which delivers air to a plexiglas cylindrical specimen holder. When the motor operates, the plunger of the syringe is pushed at a constant rate, which causes a constant air flow to be delivered through a circular specimen. The apparatus contains a pressure port for measuring the corresponding pressure drop across the specimen. This pressure drop was measured either with a mercury manometer or a slant gage having a sensitivity of less than 0.003 inches of water.

The plunger of the syringe is depressed by a piston running on a threaded rod. The rod is rotated by an electric motor and communicates with the motor through a cone-shaped drive assembly. Adjustment of the point of contact between the drive wheel and the cone allows for a continuously variable "gear ratio" from 1:1 through 1:3. Further variation in flow rate is obtainable by alteration of the syringe size.

The apparatus was tested for leaks by mounting an impermeable specimen in the holder and using a gas chromatographic leak detector. In this procedure,  $SF_6$  tracer gas was introduced into the system via the syringe, simultaneously effecting an increase in air pressure. The assembly was subsequently scanned with the probe of the detector, allowing accurate identification and elimination of any leaks.

## 3. Experimental Procedure

Each specimen was cut so as to fit tightly into the end of the cylindrical specimen holder and was sealed by applying a room-temperature vulcanizing silicone rubber at the interface of the specimen and the cylindrical holder. The full face area of the specimen was available for flow.

After a specimen was mounted in the apparatus, it was exposed to various flow rates corresponding to pressure differences between 0.1 and 0.5 inches of water. The logarithm of the flow rate ( $Q_0$ ) was plotted as a function of the logarithm of the pressure difference ( $\Delta P$ ). A least-squares procedure was applied to the raw data yielding a best-fit straight line when a mean air permeance  $\frac{k}{\mu L}$  for the data set is calculated from the relation:

$$\frac{k}{\mu L} = \frac{\sum_{i=1}^N Q_i \cdot \Delta P_i}{\sum_{i=1}^N (\Delta P_i)^2} \quad (5)$$

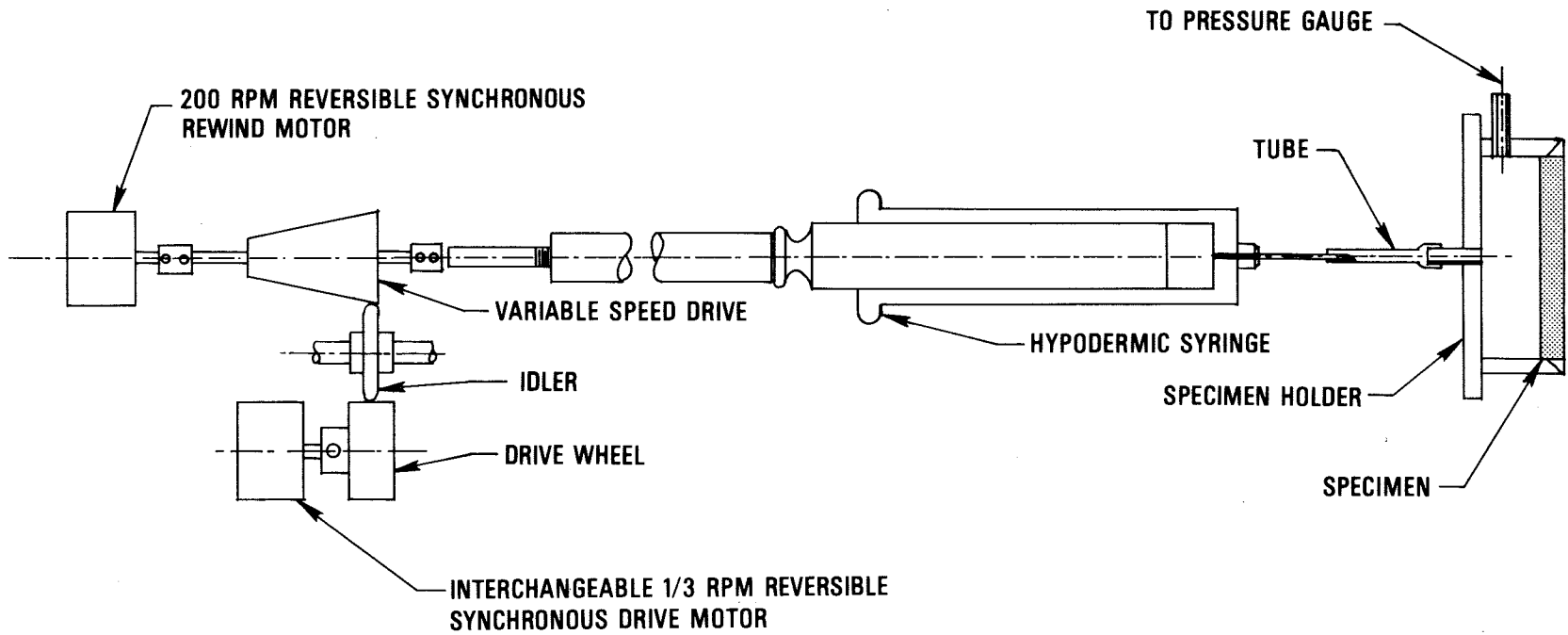

Figure A-1. Apparatus used to measure the air permeability of building materials.

where N is the number of discrete measurements. Air permeabilities were determined by multiplying air permeance values obtained from eq. (5) by the factor  $\mu L$ .

#### 4. Results and Analysis

Volumetric flow rates per unit area ( $Q_0$ ) are plotted as a function of pressure difference ( $\Delta P$ ) for various building materials in Figure A-2. It is interesting to note that the data for each of the specimens are fitted with a straight line having unity slope. This finding indicates that the fluid flow occurring through the specimens behaves consistently with a Darcy's Law model of fluid flow through a porous medium.

Air permeability values for the various building materials were calculated using eq.(5) and are summarized in Table A-1,

Table A-1. Measured Air Permeabilities of Building Materials

Building Material	Thickness Inch	Permeability $10^{-13} \cdot \text{ft}^2$
Building Paper	0.030	0.82
Asbestos Shingle	0.154	1.74
Brick	3.75	0.54
Gypsum Dry Wall with vapor barrier paint	5/8	4.2
Gypsum Dry Wall	5/8	7.5
Wood-Composition Fiber Board	1/2	105.0
Wood-Composition Fiber Board	7/16	59.0
Asphalt-Impregnated Sheathing	1/2	296.0
Polystyrene Insulation	3/4	*
Pine Board	1/2	*
Plywood	1/2	*
Plywood	3/8	*
Cedar Shingle	---	*
Redwood Shingle	---	*

\* too impermeable to measure.



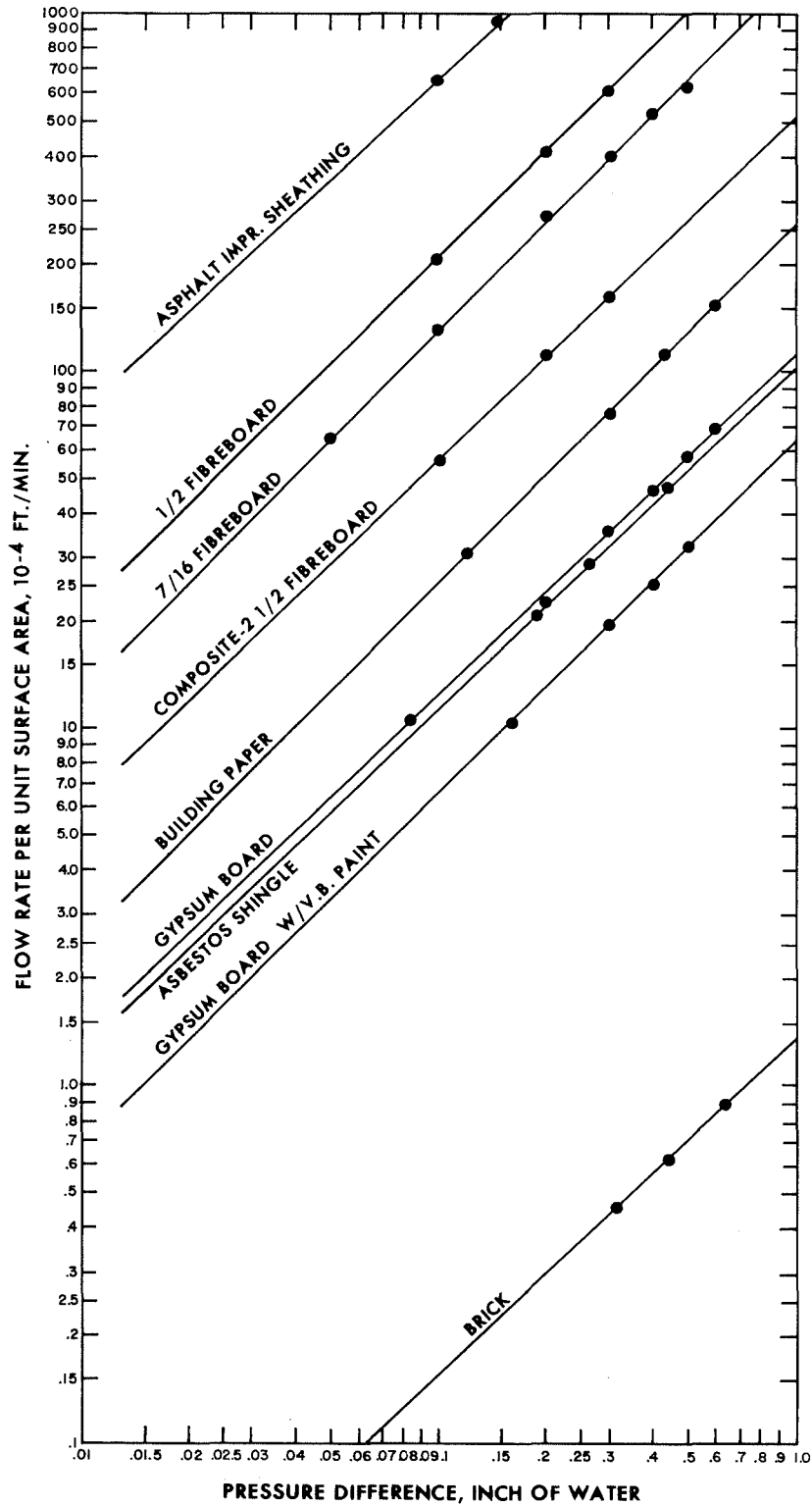

Figure A-2. Air permeation through various building materials as a function of pressure difference.

These data were then used to examine whether or not air leakage through the solid materials in the building elements could account for a significant part of the measured leakage through the ceiling and exterior and party walls of the test house.

The induced flow rate through a brick wall of the test house is calculated below for the case of a 7-1/2-mph and a 15-mph wind blowing normal to the wall. Details for these calculations are given in the following:

The overall resistance to air permeation through the brick wall is calculated in Table A2.

Table A2. Calculation of the Resistance to Air Permeation Through a Brick Wall

Construction Details	Resistance to Air Permeation $\frac{\mu L}{k}$ $10^4 \cdot \text{lb} \cdot \text{sec} / \text{ft}^3$
1/2-in Gypsum Dry Wall	2.67
3-1/2-in Insulation	negligible
1/2-in Asphalt-Impregnated Sheathing	0.054
0.030-in Building Paper	1.18
3-1/2-in Brick Facing	208.0

$$\text{Total Resistance to Air Permeation} = 212 \times 10^4 \text{ lb} \cdot \text{sec} / \text{ft}^3$$

When a 7-1/2-mph wind is decelerated at the wall, a stagnation pressure of 0.139 lb/ft<sup>2</sup> is developed. For the case of a 15-mph wind, a stagnation pressure of 0.556 lb/ft<sup>2</sup> is developed. Therefore, the air flow rate through the brick wall is given by

$$Q_o = \frac{\Delta P}{\left(\frac{\mu L}{k}\right)_1 + \left(\frac{\mu L}{k}\right)_2 + \dots + \left(\frac{\mu L}{k}\right)_n}$$

or 
$$Q_o = \frac{0.139}{212 \times 10^4} = 6.56 \times 10^{-8} \frac{\text{ft}}{\text{sec}} \quad (\text{for } 7\text{-}1/2\text{-mph wind})$$

$$Q_o = \frac{0.556}{212 \times 10^4} = 26.2 \times 10^{-8} \frac{\text{ft}}{\text{sec}} \quad (\text{for } 15\text{-mph wind}).$$

The surface area of the front brick wall of the test house is approximately 290 ft<sup>2</sup>. The flow rate through the brick wall is 1.1 x 10<sup>-3</sup> ft<sup>3</sup>/min for the case of a 7-1/2-mph wind and 4.6 x 10<sup>-3</sup> ft<sup>3</sup>/min for the case of a 15-mph wind.

Suppose the resistance to air flow offered by the brick is neglected, then we obtain:

$$Q_o = \frac{0.139}{3.90 \times 10^4} = 3.6 \times 10^{-6} \frac{\text{ft}}{\text{sec}} \quad (\text{for } 7\text{-}1/2\text{-mph wind})$$

$$Q_o = \frac{0.556}{3.90 \times 10^4} = 14.3 \times 10^{-6} \frac{\text{ft}}{\text{sec}} \quad (\text{for } 15\text{-mph wind})$$

When the brick is excluded, the flow rate is calculated to be 0.063 ft<sup>3</sup>/min for the case of a 7-1/2-mph wind and 0.25 ft<sup>3</sup>/min for the case of a 15-mph wind. Utilization of stagnation pressures based on the ASHRAE handbook probably overrates the actual pressure difference across the wall due to wind, so the actual resulting leakage due to permeation could be less. In any case, the leakage due to permeation is seen to be of very low magnitude.

Under typical conditions, the rate of air infiltration for the test house was measured to be 0.72 air changes per hour. This figure corresponds to 111.9 ft<sup>3</sup>/min. The foregoing air leakage values due to air permeation are insignificant in comparison to the overall rate of air-infiltration.

It was therefore concluded that air leakage due to air permeation through solid building materials did not contribute to the overall rate of air infiltration for the test house. The foregoing analysis neglects air flow through the joints where building materials come together.

## NOMENCLATURE

- $a$  = flow coefficient
- $a_T$  = total flow coefficient
- $a_R$  = reduction flow coefficient
- $c$  = concentration of tracer gas
- $c_0$  = initial concentration of tracer gas
- $f$  = fraction of air lost by duct leaks
- $I$  = rate of air infiltration
- $\Delta I$  = increase in rate of air infiltration
- $k$  = permeability of porous medium
- $L$  = thickness
- $n$  = flow rate relation exponent
- $n_T$  = initial exponent
- $n_R$  = reduction exponent
- $\Delta P$  = pressure difference
- $Q$  = flow rate through crack
- $Q_0$  = superficial flow rate per unit surface area
- $t$  = time
- $T_i$  = indoor air temperature
- $T_o$  = outdoor air temperature
- $\dot{u}$  = air-delivery rate of blower
- $\dot{v}$  = rate at which air enters or leaves the enclosure
- $V$  = volume of enclosure
- $\mu$  = dynamic viscosity of air

SI CONVERSION CHART

<u>Physical Quantity</u>	<u>To Convert From</u>	<u>To</u>	<u>Multiply by</u>
Length	in	m	$2.54 (10^{-2})$
Length	ft	m	$3.05 (10^{-1})$
Area	ft <sup>2</sup>	m <sup>2</sup>	$9.29 (10^{-2})$
Volume	ft <sup>3</sup>	m <sup>3</sup>	$2.83 (10^{-2})$
Volumetric Flow rate	ft <sup>3</sup> /min	m <sup>3</sup> /s	$4.72 (10^{-4})$
Velocity	ft/min	m/s	$5.08 (10^{-3})$
Power	Btu/h	W	$2.93 (10^{-1})$
Dynamic Viscosity	lbf·sec/ft <sup>2</sup>	Pa·s	$4.79 (10^1)$
Pressure Difference	in H <sub>2</sub> O	Pa	$2.49 (10^{-2})$
Temperature	°F	°C	$T_C = (T_F - 32)/1.8$

U.S. DEPT. OF COMM. BIBLIOGRAPHIC DATA SHEET	1. PUBLICATION OR REPORT NO.  NBS TN 992	2. Gov't Accession No.	3. Recipient's Accession No.
4. TITLE AND SUBTITLE  AN INVESTIGATION OF AIR-INFILTRATION CHARACTERISTICS AND MECHANISMS FOR A TOWNHOUSE		5. Publication Date  August 1979	
7. AUTHOR(S)  S.J. Treado, D.M. Burch, and C.M. Hunt		6. Performing Organization Code	
9. PERFORMING ORGANIZATION NAME AND ADDRESS  NATIONAL BUREAU OF STANDARDS DEPARTMENT OF COMMERCE WASHINGTON, DC 20234		8. Performing Organ. Report No.	
12. SPONSORING ORGANIZATION NAME AND COMPLETE ADDRESS (Street, City, State, ZIP) Naval Facilities Engineering Command, U.S. Navy, Washington, DC 20390; Directorate of Civil Engineering, U.S. Air Force, Washington, DC 20330; and Office of Chief of Engineers, U.S. Army, Washington, DC 20314.		10. Project/Task/Work Unit No.	
15. SUPPLEMENTARY NOTES  <input type="checkbox"/> Document describes a computer program; SF-185, FIPS Software Summary, is attached.		11. Contract/Grant No.	
16. ABSTRACT (A 200-word or less factual summary of most significant information. If document includes a significant bibliography or literature survey, mention it here.)  Air infiltration measurements using a tracer-gas technique and the pressurization technique were performed on a three-bedroom townhouse having a gas-fired, forced-air furnace system, in order to quantify the amount of air infiltration due to various mechanisms. These mechanisms include combustion and draft-diverter air requirements, air leakage from supply-air ducts, and air leakage through the solid parts of the building envelope as well as air leakage through cracks around windows and doors. A thermographic survey was also performed in conjunction with pressurization of the structure, in an attempt to identify specific leaks. An apparatus for measuring the air permeability of building materials was used to analyze the significance of air permeation through solid building elements. Based on the findings of the study, general guidelines are presented for reducing air infiltration in residences.		13. Type of Report & Period Covered  Final	
17. KEY WORDS (six to twelve entries; alphabetical order; capitalize only the first letter of the first key word unless a proper name; separated by semicolons)  Air infiltration, residential; air permeability of houses; energy conservation; pressurization technique; tracer-gas technique.		14. Sponsoring Agency Code	
18. AVAILABILITY  <input type="checkbox"/> Unlimited  <input type="checkbox"/> For Official Distribution. Do Not Release to NTIS  <input checked="" type="checkbox"/> Order From Sup. of Doc., U.S. Government Printing Office, Washington, DC 20402, SD Stock No. SN003-003-  <input type="checkbox"/> Order From National Technical Information Service (NTIS), Springfield, VA, 22161	19. SECURITY CLASS (THIS REPORT)  UNCLASSIFIED	21. NO. OF PRINTED PAGES  36	
20. SECURITY CLASS (THIS PAGE)  UNCLASSIFIED		22. Price	

# NBS TECHNICAL PUBLICATIONS

## PERIODICALS

**JOURNAL OF RESEARCH**—The Journal of Research of the National Bureau of Standards reports NBS research and development in those disciplines of the physical and engineering sciences in which the Bureau is active. These include physics, chemistry, engineering, mathematics, and computer sciences. Papers cover a broad range of subjects, with major emphasis on measurement methodology, and the basic technology underlying standardization. Also included from time to time are survey articles on topics closely related to the Bureau's technical and scientific programs. As a special service to subscribers each issue contains complete citations to all recent NBS publications in NBS and non-NBS media. Issued six times a year. Annual subscription: domestic \$17.00; foreign \$21.25. Single copy, \$3.00 domestic; \$3.75 foreign.

Note: The Journal was formerly published in two sections: Section A "Physics and Chemistry" and Section B "Mathematical Sciences."

### DIMENSIONS/NBS

This monthly magazine is published to inform scientists, engineers, businessmen, industry, teachers, students, and consumers of the latest advances in science and technology, with primary emphasis on the work at NBS. The magazine highlights and reviews such issues as energy research, fire protection, building technology, metric conversion, pollution abatement, health and safety, and consumer product performance. In addition, it reports the results of Bureau programs in measurement standards and techniques, properties of matter and materials, engineering standards and services, instrumentation, and automatic data processing.

Annual subscription: Domestic, \$11.00; Foreign \$13.75

## NONPERIODICALS

**Monographs**—Major contributions to the technical literature on various subjects related to the Bureau's scientific and technical activities.

**Handbooks**—Recommended codes of engineering and industrial practice (including safety codes) developed in cooperation with interested industries, professional organizations, and regulatory bodies.

**Special Publications**—Include proceedings of conferences sponsored by NBS, NBS annual reports, and other special publications appropriate to this grouping such as wall charts, pocket cards, and bibliographies.

**Applied Mathematics Series**—Mathematical tables, manuals, and studies of special interest to physicists, engineers, chemists, biologists, mathematicians, computer programmers, and others engaged in scientific and technical work.

**National Standard Reference Data Series**—Provides quantitative data on the physical and chemical properties of materials, compiled from the world's literature and critically evaluated. Developed under a world-wide program coordinated by NBS. Program under authority of National Standard Data Act (Public Law 90-396).

## BIBLIOGRAPHIC SUBSCRIPTION SERVICES

The following current-awareness and literature-survey bibliographies are issued periodically by the Bureau:

**Cryogenic Data Center Current Awareness Service.** A literature survey issued biweekly. Annual subscription: Domestic, \$25.00; Foreign, \$30.00.

**Liquefied Natural Gas.** A literature survey issued quarterly. Annual subscription: \$20.00.

NOTE: At present the principal publication outlet for these data is the Journal of Physical and Chemical Reference Data (JPCRD) published quarterly for NBS by the American Chemical Society (ACS) and the American Institute of Physics (AIP). Subscriptions, reprints, and supplements available from ACS, 1155 Sixteenth St. N.W., Wash., D.C. 20056.

**Building Science Series**—Disseminates technical information developed at the Bureau on building materials, components, systems, and whole structures. The series presents research results, test methods, and performance criteria related to the structural and environmental functions and the durability and safety characteristics of building elements and systems.

**Technical Notes**—Studies or reports which are complete in themselves but restrictive in their treatment of a subject. Analogous to monographs but not so comprehensive in scope or definitive in treatment of the subject area. Often serve as a vehicle for final reports of work performed at NBS under the sponsorship of other government agencies.

**Voluntary Product Standards**—Developed under procedures published by the Department of Commerce in Part 10, Title 15, of the Code of Federal Regulations. The purpose of the standards is to establish nationally recognized requirements for products, and to provide all concerned interests with a basis for common understanding of the characteristics of the products. NBS administers this program as a supplement to the activities of the private sector standardizing organizations.

**Consumer Information Series**—Practical information, based on NBS research and experience, covering areas of interest to the consumer. Easily understandable language and illustrations provide useful background knowledge for shopping in today's technological marketplace.

Order above NBS publications from: Superintendent of Documents, Government Printing Office, Washington, D.C. 20402.

Order following NBS publications—NBSIR's and FIPS from the National Technical Information Services, Springfield, Va. 22161.

**Federal Information Processing Standards Publications (FIPS PUB)**—Publications in this series collectively constitute the Federal Information Processing Standards Register. Register serves as the official source of information in the Federal Government regarding standards issued by NBS pursuant to the Federal Property and Administrative Services Act of 1949 as amended, Public Law 89-306 (79 Stat. 1127), and as implemented by Executive Order 11717 (38 FR 12315, dated May 11, 1973) and Part 6 of Title 15 CFR (Code of Federal Regulations).

**NBS Interagency Reports (NBSIR)**—A special series of interim or final reports on work performed by NBS for outside sponsors (both government and non-government). In general, initial distribution is handled by the sponsor; public distribution is by the National Technical Information Services (Springfield, Va. 22161) in paper copy or microfiche form.

**Superconducting Devices and Materials.** A literature survey issued quarterly. Annual subscription: \$30.00. Send subscription orders and remittances for the preceding bibliographic services to National Bureau of Standards, Cryogenic Data Center (736.00) Boulder, Colorado 80303.