

# A computer model for analysing smoke movement in buildings

E Evers and A Waterhouse

Fire Research Station



BUILDING  
RESEARCH  
ESTABLISHMENT

Department of the Environment

## A COMPUTER MODEL FOR ANALYSING SMOKE MOVEMENT IN BUILDINGS

---

E Evers\* and A Waterhouse\*

---

This report describes the computer program developed for the Fire Research Station by Scientific Control Systems Ltd to predict the movement of smoke from a fire in a building. This can be run in either deterministic or stochastic modes.

The physical model used to describe the movement of smoke through a building is explained and the computer technique used to solve the resulting equations outlined. Some preliminary results obtained with the model are presented and possible improvements considered. In the final section of the report the applications of the model are discussed.

The work was carried out under contract to the Fire Research Station to whom all queries arising from this paper should be addressed.

\*Scicon, Sanderson House, 49–52 Berners Street, London

Building Research Establishment  
Fire Research Station  
Borehamwood  
Hertfordshire  
WD6 2BL

---

## Current papers

---

Current Papers are circulated to selected audience groups appropriate to each subject. Full details of all recent Current Papers and other BRE Publications are published quarterly in BRE NEWS. Requests for BRE NEWS or for placing on the Current Paper mailing list should be addressed to:

**Distribution Unit,  
Building Research Establishment  
Garston, Watford, WD2 7JR**

Extra copies of this paper are available, a charge may be made for supplies in quantity.

© Crown copyright 1978

Limited extracts from the text may be produced provided the source is acknowledged. For more extensive reproduction, please write to the Publications Officer at the Fire Research Station.

---

# A COMPUTER MODEL FOR ANALYSING SMOKE MOVEMENT IN BUILDINGS

by E Evers and A Waterhouse

## 1 INTRODUCTION

Although fire itself is a major threat to building occupants in its immediate vicinity, it is frequently the smoke which poses the greatest threat to those occupants who are remote from the fire. Smoke and fumes present a hazard by spreading to occupied areas and escape routes. Because even a small fire can generate considerable volumes of smoke and threaten great numbers of occupants, it is essential that smoke movement be controlled.

In order to be able to study smoke movement without the risk of loss of life or property we have developed an analytical model to simulate the spread of smoke through buildings.

Section 2 of this report describes the physical equations of motion we use to model the movement of smoke caused by fire in a building, and explains the simplifying assumptions that we make in this model. Section 3 outlines the techniques used for solving the resulting equations. In Section 4 we consider the stochastic aspects of the simulation. Section 5 presents some preliminary results obtained with the model and considers possible improvements. In Section 6 we discuss the applications of the model and possible extensions in order to be able to calculate directly the risk to occupants in all parts of a building.

During this work we have been concerned with a particular type of building. Typical examples include office blocks, flats and hospitals. These buildings are divided up into small compartments, corridors and vertical shafts. They may have mechanical ventilation systems.

## 2 SMOKE MOVEMENT IN BUILDINGS

In this section we describe the physical equations of motion that we are using to model the movement of smoke caused by a fire in a building, and explain the simplifying assumptions that we are making in this model. The main influences which provide the motive forces for air movement within a building are fire, stack effect, wind and mechanical ventilation. As far as movement is concerned, smoky and normal atmospheres at the same temperature are virtually indistinguishable. So, at some distance from the source of the fire, we can examine the spread of smoke through a building by considering only the normal aerial currents. In the neighbourhood of the fire extra movement occurs as a result of the buoyancy forces caused by the temperature differentials which are established.

The building is considered as a series of spaces or nodes each at a specific pressure with air movement between them from areas of high to areas of low pressure. In order to analyse the smoke flow, we determine the inflow and outflow of air from each node through such paths as windows, doors, and ventilation openings. We can then examine the way in which the smoke concentration increases with time at each node.

### 2.1 Stack effect

Stack or chimney effect is the name given to the air movement resulting from a difference in temperature between air inside and outside the building. These differences result in differences in air density so that, over vertical distances, pressure gradients between inside and out exist. For example if the air temperature within a building is higher than the outside, an internal pressure lower than the external pressure is produced in the lower part of the building, with an inward flow of air as a result. The direction of flow is reversed at the upper levels of the building. The height of the neutral plane is determined by the relative leakage areas of the building structure at high and low levels. The relative significance of the stack effect, compared with other effects determining the movement of air through the building, is dependent on the overall height of the building and also on the magnitude of the temperature differential existing between the inside and outside air.

## 2.2 Effect of wind

The slowing down of wind by a building creates a build up of pressure on the windward face. The wind is deflected around the sides and over the roof of the building, creating an eddy behind the building and exerting a negative pressure or suction on all areas other than the windward face.

The pressure distribution on the surface of a building due to wind is not uniform, and depends on such factors as wind direction, shape and height of the building, and the shielding effects of surrounding buildings. The pressure is given, in terms of the pressure coefficient  $C_p$ , by<sup>1</sup>:

$$P_w = P - P_o = C_p \rho \frac{V^2}{2}$$

where  $P_w$  = wind pressure head  
 $P$  = total pressure  
 $P_o$  = static pressure at that level  
 $V$  = wind speed  
 $\rho$  = air density

Typical values for the wind pressure coefficient  $C_p$  are given as functions of the angle between wind direction and the normal to the wall as follows<sup>2</sup>:

$$\begin{aligned} C_p &= 0.75 & 0^\circ < [\theta] \leq 30^\circ \\ C_p &= -0.021 \theta + 1.38 & 30^\circ < [\theta] \leq 90^\circ \\ C_p &= -0.5 & [\theta] > 90^\circ \end{aligned}$$

The wind speed  $V$  varies with height because of the frictional drag at the earth's surface. The exact form of the velocity profile is dependent on the surrounding terrain. The expression used is:

$$\frac{V}{V_{10}} = \left( \frac{h}{10} \right)^\beta$$

where  $V_{10}$  is the meteorological wind speed usually quoted for a standard height of 10 m above ground. Appropriate values of  $\beta$  for mean wind speeds in the UK are 0.17 and 0.35 for open country and urban areas respectively<sup>1</sup>.

The presence of wind modifies the stack effect. The pressure differentials caused by the wind result in a separation of the neutral pressure planes of the windward and leeward walls.

## 2.3 Ventilation systems

Most mechanical ventilation systems are designed so that, under normal operating conditions, air is fed into and extracted from various parts of the building at fixed mass flow rates. In the event of a fire this system could considerably accelerate the circulation of smoke to other parts of the building. It is common practice, on the automatic detection of a fire, either to switch off the system entirely or to close down some of the ducts to prevent the rapid spread of smoke through the system. If the system is shut down, the ventilation ducts may still provide some additional air flow paths which will affect the smoke spread. There may also be an emergency ventilation system which, on detection of a fire, operates in a special way to inhibit the spread of smoke through the building.

### Effect of a fire

When a fire occurs in a building a large quantity of hot gas and smoke is generated which is moved around by the action of the pressure differences which are established.

### 2.5 Flow paths

Air flows from high pressure to low pressure regions through leakage paths. The amount of air flowing depends on the resistance offered by the separations. In practice these separations are doors and windows, which may be either open or closed, and ventilation ducts. Leakage flow can also occur through floor and wall constructions, but this flow is assumed to be negligible in comparison with other effects.

A general expression for the mass flow rate  $Q$  through a path in terms of the pressure differential  $\Delta P$  across the opening is  $Q \propto (\Delta P)^{1/n}$ . For general openings  $n = 2$  and for capillary path flow  $n = 1$ . An HVRA report to FRS<sup>1</sup> recommends the use of  $n = 2$  for cracks around closed doors and  $n = 1.6$  for cracks around closed windows. Without significant loss of accuracy, we may use  $n = 2$  for all the flow paths considered. The general equation relating mass flow rate to pressure differential across an opening is<sup>3</sup>:

$$Q = \sqrt{\frac{\Delta P}{R}}$$

where  $R$  = flow resistance of the opening

$$= \frac{1}{2\rho (\alpha A)^2}$$

$\alpha$  = flow coefficient of the opening

$\rho$  = density of the air passing through the opening

$A$  = area of the opening

This equation is appropriate to the flow through all openings, including open doors and windows. The flow coefficient is taken as 0.65 for all openings<sup>1</sup>.

When two spaces adjoining each other have different temperatures, there is a difference in air density, so that over vertical distances pressure gradients between the two spaces exist. If a neutral axis exists between the levels of the top and bottom of the opening, air flows in through one part of the opening and out through the other. The mass flow rates  $Q_1$  and  $Q_2$  through the upper and lower parts are given by:

$$Q_1 = \pm \sqrt{\frac{4|\Delta P_{\max 1}|}{9R_1}} \quad Q_2 = \pm \sqrt{\frac{4|\Delta P_{\max 2}|}{9R_2}}$$

where  $\Delta P_{\max 1}$  and  $\Delta P_{\max 2}$  are the maximum pressure differences at the inflowing and outflowing sides<sup>3</sup>.

### 2.6 Smoke spread and concentration

The pressures in all parts of the building and the air flow rates through all the openings or paths are obtained by solving an air flow network composed of flow resistances and such motive forces as wind pressure and stack effect. To estimate the safety of occupants in different parts of the building, we calculate the length of time taken initially for the smoke to reach that part and examine the way in which the smoke concentration builds up after this time.

The calculation of the smoke spread during the initial growth of the fire is exceedingly complex, because the air flow system is in a very unsteady state due to the transient temperatures in the vicinity of the fire.

The inclusion of these transient effects in the model would increase the complexity of the calculations considerably. As the primary objective of this work is to examine the effect of the stochastic environment on the smoke spread, the additional complexity and increased computing time required to include these transient effects was not considered to be initially justified. We therefore make the simplifying assumption that the flow is in a steady state throughout the fire. This is equivalent to the assumption that the temperatures in all parts of the building, including the fire compartment, are stable, or that the time constants of the smoke spread are much greater than the time constants of fire growth.

Having calculated the air flow pattern for the entire building, we know the pressure level in all compartments and also the rate and direction of the flow along all the interconnections. We can then calculate the initial rate of spread of the smoke and examine the build up of smoke concentration in all parts of the building. We make the following assumptions:

- (1) Smoke diffuses instantaneously in all compartments except vertical shafts and the corridor outside the fire room.
- (2) The smoke head flows initially in vertical shafts at the same velocity as the flow in the steady state.

The concentration of smoke in any part of the building is determined relative to the concentration in the fire room. We calculate the amount of dilution that has occurred since the smoke emerged from the fire room. Thus the calculations serve equally well to obtain the concentration of a toxic gas relative to the concentration in the fire room.

### **2.7 The fire compartment**

The whole of the fire compartment is assumed to be at a uniform high temperature. This temperature is limited by the amount of air flowing into the compartment, and is also dependent on the fuel availability and type, and the volume of the compartment. Because of the temperature differential between the fire compartment and the air outside it, a neutral axis exists at each opening. Below this neutral axis air flows into the compartment and above it hot gases flow out of the compartment. We assume that the height of the neutral axis at all openings is the same as that at the door of the room. The height of this neutral plane is determined by the relative leakage paths from the compartment at high and low levels.

As we are assuming that the fire temperature has already reached a steady state the initial expansion of the gases in the compartment as the temperature rises is neglected. Any mass production by the fire is also neglected. Having determined the compartment in which it is located the fire is entirely specified by two parameters:

- (1) Temperature of the fire compartment
- (2) Some measure of the concentration of the smoke emerging from the fire compartment.

During the course of a fire the windows of the compartment may break as a result of the heat produced, and the door of the compartment may burn down. We have assumed initially that if the windows break then they will break immediately at flashover. Similarly we assume that the length of time taken for the door to burn down is greater than the evacuation time of the buildings with which we are initially concerned, so that these events will not affect the steady state of the air flow pattern within the building, during the time scale of the calculations.

### **2.8 Smoke flow in the corridor on the floor of the fire**

The nature of smoke flow in the corridor on the floor of the fire is very important in determining the spread of the smoke to other floors. A layer of hot gases forms under the ceiling. Smoke flows away from the burning compartment in the upper part of the corridor, and cool air flows toward the burning compartment in the lower part.

The temperature of the hot gases in the layer under the ceiling is a function of the distance from the fire compartment. The form of this dependence is as follows<sup>4</sup>.

$$\theta_x = K_1 \theta_f \text{Exp} (-K_2 x)$$

where  $\theta_x$  = temperature (above ambient) of the gas in the layer at distance x along the corridor from the fire room.

$\theta_f$  = temperature (above ambient) in the fire compartment.

$K_1$  is an inverse measure of the amount of mixing which the gases flowing into the corridor from the fire room undergo. Current estimates from the values of  $K_1$  are:

$K_1 = 0.05$  when the fire door is closed

$K_1 = 0.5$  when the door is open.

$K_2$  is a measure of the heat transferred to the walls and ceiling of the corridor and is given by:

$$K_2 = \frac{HWK_1}{m_o S}$$

where H = Newtonian heat transfer coefficient

= 20 w/m<sup>2</sup> deg C.

W = width of the corridor

$m_o$  = mass rate of flow of hot gases into the corridor

S = specific heat of smoke.

We assume that the layer of smoke is at a constant depth throughout the length of the corridor. The depth of the layer of hot gases is taken to be:

$$d = K_3 h$$

where h = height of the corridor

and the current best estimate<sup>4</sup> for  $K_3 = 0.5$ . Experiments are being conducted to verify these estimates for  $K_1$ ,  $K_2$  and  $K_3$ .

The length of time taken to establish this layer under this ceiling is not accurately known. The expression currently used in the model is<sup>5</sup>:

$$t = \frac{\ell Wd K_1 \rho_o}{m_o}$$

where  $\ell$  is the length of the corridor. This formula is obtained by assuming that the smoke layer forms immediately under the ceiling along the entire length of the corridor, and that the depth of this layer increases uniformly from 0 to d.

## 2.9 Smoke flow in vertical shafts

In order to calculate the time taken for the smoke to reach other floors we analyse the flow in vertical shafts, such as stairwells, lift shafts and ventilation ducts. We assume that the smoke head flows initially in the shaft at the same velocity as the flow in the steady state.

$Q_k$  is the mass flow rate of air into the shaft at the  $K^{\text{th}}$  floor. For  $i > f$ , if  $\sum_{k=1}^n Q_k > 0$  for

each  $f \leq n \leq i - 1$  where f is the fire floor, smoke will flow up the shaft to floor i. The time taken for the smoke head to reach the  $i^{\text{th}}$  floor from the burning floor f, is given by<sup>2</sup>:



$$T_i = \sum_{n=f}^{i-1} \frac{\rho H A}{\sum_{k=1}^n Q_k}$$

where  $\rho$  = air density

H = distance between successive floors

A = effective cross-sectional area of the shaft.

For  $i < f$ , if  $\sum_{k=1}^n Q_k < 0$  for each  $i \leq n < f-1$ , then smoke will flow down to the  $i^{\text{th}}$  floor, and  $T_i$  is given by:

$$T_i = \sum_{n=1}^{f-1} \frac{\rho H A}{\sum_{k=1}^n Q_k}$$

If  $Q_k > 0$ , for any K, no smoke will flow into the  $K^{\text{th}}$  floor from the shaft.

The concentration  $C_i$  of smoke in the shaft on the  $i^{\text{th}}$  floor level is given by:

$$C_i = \frac{C_{i-1} F_{i-1}}{F_i} \quad \text{for flow up the shaft from } (i-1)^{\text{th}} \text{ floor}$$

$$C_i = \frac{C_{i+1} F_{i+1}}{F_i} \quad \text{for flow down from the } (i+1)^{\text{th}} \text{ floor}$$

where  $F_i$  = mass flow rate up the shaft from floor  $i$  to floor  $(i+1)$ .

and  $C_i$  is the concentration of smoke flowing into or out of the  $k^{\text{th}}$  floor.

## 2.10 Smoke concentration in a general compartment

Since concentrations are additive, the smoke concentration at any node in the building can be considered as a sum of the concentrations resulting from the inflow of smoke at each of the openings to that node. If the opening from the specified node is direct from a vertical shaft, the contribution to the smoke density at the node at time  $t$  after flashover is:

$$\frac{C_s Q_s}{\sum Q_1} \left\{ 1 - e^{-\frac{\sum Q_1}{\rho V_1} (t - T_s)} \right\}$$

where  $C_s$  = concentration of the smoke in the shaft

$Q_s$  = mass flow rate from the shaft

$\sum Q_1$  = sum of all flows out of node

$V_1$  = volume of the node

$T_s$  = time at which smoke head reaches this level in the shaft

$\rho$  = air density

If smoke flows into the specified node from a vertical shaft through another node, the contribution to the smoke density at the specified node at time  $t$  is:

$$\frac{C_s Q_s Q_r}{\Sigma Q_2} \left\{ \frac{1}{\Sigma Q_1} \left( 1 - e^{-\frac{\Sigma Q_1}{\rho V_1} (t - T_s)} + e^{-\frac{\Sigma Q_2}{\rho V_2} (t - T_s) - \frac{\Sigma Q_1}{\rho V_1} (t - T_s)} \right) \right\}$$

- where  $Q_r$  = mass flow rate from the intermediate node into the specified node  
 $\Sigma Q_1$  = sum of all flows out of intermediate node  
 $V_1$  = volume of intermediate node  
 $\Sigma Q_2$  = sum of all flows out of specified node  
 $V_2$  = volume of specified node.

The derivation of these expressions is given in Appendix B.

### 2.11 Assumptions

We conclude this chapter by evaluating the principle assumptions on which the smoke spread model is based. The assumptions are listed below:

- 1 Each compartment or node of the building (except the fire compartment) is considered to be at a uniform pressure throughout the compartment.
- 2 During the initial stages of the fire the air flow system is in a very unsteady state due to the transient temperatures in the vicinity of the fire. We have ignored these transient effects and have assumed that the flow is in a steady state throughout the fire. This is the most important simplifying assumption that we have made in the model. It is equivalent to the assumption that the temperatures in all parts of the building, including the fire compartment, are stable, or that the time constants of smoke spread are much greater than the time constants of fire growth.
- 3 As far as movement is concerned smoky and normal atmospheres at the same temperature are indistinguishable so that away from the source of the fire we can examine the smoke spread by considering only the normal aerial currents. Only in the immediate vicinity of the fire (ie in the fire compartment and the corridor outside) do we consider the extra movement resulting from the buoyancy forces created by the temperature differences which are established. This assumption is reasonable unless all the doors are open and the smoke head has very easy access to floors away from the fire.
- 4 Smoke diffuses instantaneously in all compartments except vertical shafts and the corridor outside the fire room. This simplification will affect the rate at which smoke spreads into compartments leading off a corridor on floors away from the fire. However the consequences of this assumption are not thought to be very important.
- 5 The smoke head flows initially in vertical shafts at the same velocity as the flow in a steady state. This assumption represents a considerable simplification of the true behaviour of smoke in shafts and it considerably increases the length of time taken for smoke to reach other floors. This is thought to be one of the major weaknesses of the existing model.
- 6 The fire compartment itself is assumed to be at a uniform temperature. The initial expansion of gases has been neglected, and also any mass production by the fire. We assume that there is one neutral pressure plane in the fire room. The height of this plane is taken to be the height of the neutral axis at the door. The effect of this approximation will be greatest when the window of the fire room is shut and the door is open.

- 7 If the windows in the fire compartment break as a result of the heat of the fire, they are assumed to break immediately at flashover. This assumption is reasonable for the ventilation controlled fires with which we are concerned. Also the time it takes for the fire door to burn down is assumed to be greater than the evacuation time of the buildings with which we are concerned. These assumptions are necessary in order to maintain the steady state of the flow system.
- 8 In the corridor outside the fire room a layer of hot gases forms under the ceiling. This layer is assumed to be of constant depth.

### 3 COMPUTER TECHNIQUE FOR FLOW ANALYSIS

In Chapter 2 we described the equations of motion that we use in the smoke model. Firstly we considered the motive forces which result in air movement in buildings. We explained that, with certain simplifying assumptions, the flow system could be considered to be in a steady state throughout the duration of the fire. We then described the expressions used to represent the spread of smoke through a building. In this chapter we describe the computer technique used to determine the steady state air flow pattern within the building.

Although it is relatively simple to calculate the air flow through a single aperture given the appropriate values of pressure and size of the opening, the problem becomes extremely complex when a complete building, with its external and internal pressure gradients and multiple flow paths, is considered. The use of a digital computer is essential.

The air flow paths of the building are defined by a series of interconnected nodes. Each node in the network represents a particular zone of the building. Associated with each air flow path is a resistance, dependent upon the size of the opening. The pressure difference and air flow rate across each opening are obtained by solving a flow network consisting of these resistances and motive forces such as wind pressure and stack effect. In this section we derive the equations of the flow network and describe the method of solution.

The equations are obtained by the application of two laws:

- (a) The law of constancy of mass at each node
- (b) Bernoulli's law

These two physical laws are analogous to Kirchoff's first and second laws of electrical circuit theory and we use this analogy to solve the air flow network.

If the building is divided into  $v$  zones (or nodes) and there are  $n$  air flow paths, the application of the law of constancy of mass provides  $v - 1$  linearly independent equations of the form:

$$\sum_{j=1}^n a_{ij} q_j = 0$$

where  $q_j$  = mass flow rate along the  $j^{\text{th}}$  flow path

and  $a_{ij} = 0$  if the  $j^{\text{th}}$  flow path is not incident on the  $i^{\text{th}}$  node  
 $\pm 1$  otherwise

Similarly the application of Bernoulli's law gives  $n - v + 1$  linearly independent equations of the form:

$$\sum_{j=1}^n b_{ij} p_j = 0$$

where  $p_j$  = pressure difference across the  $j^{\text{th}}$  flow path

and  $b_{ij} = 0$  if the  $j^{\text{th}}$  flow path is not included in the  $i^{\text{th}}$  circuit  
 $\pm 1$  otherwise

In addition we have  $n$  equations, known as terminal relations, relating the pressure difference across each flow path to the mass flow rate. The terminal relations are of the form:

$$p_j = \pm r_j q_j^2 \quad \text{where } r_j = \text{constant}$$

$$\text{or } p_j = \text{constant}$$

$$\text{or } q_j = \text{constant}$$

The unknowns in these equations are the pressure differences  $p_j$  and the mass flow rates  $q_j$  along each air flow path.

Thus we have a total of  $2n$  linearly independent equations with  $2n$  unknowns.

The method of solution which has been adopted is outlined below. An important difference for applying the network theory to the flow system is that the terminal relations across an opening are non-linear, whereas in electrical theory the voltage drop across a resistance is directly proportional to the current flow. For the determination of the direction of flow through openings this non-linearity in the equations introduces considerable complexity into the problem.

We solve the set of non-linear equations by using successive linear approximations to the terminal relations across each non-linear component. We then solve a series of networks governed by linear equations. The linear approximations used at each iteration are based on the solution of the previous iteration. By suitable choice of starting approximations and linearisation technique convergence to the desired solution can be obtained.

At each iteration we have to solve a network which is described by a set of linear equations, and is directly analogous to an electrical circuit. Because of the large number of flow paths in a building, it is necessary to subdivide the network in some way and to obtain partial solutions to each subnetwork, before recombining the network to derive the whole solution. A convenient unit to use as a subnetwork is one floor of the building. In this way we can take advantage of the fact that two or more floors of the building may have exactly similar layouts.

The only connecting air flow paths between adjacent floors are the outside air and the vertical shafts. we isolate the flow path network for each floor. This subnetwork is of the following form:

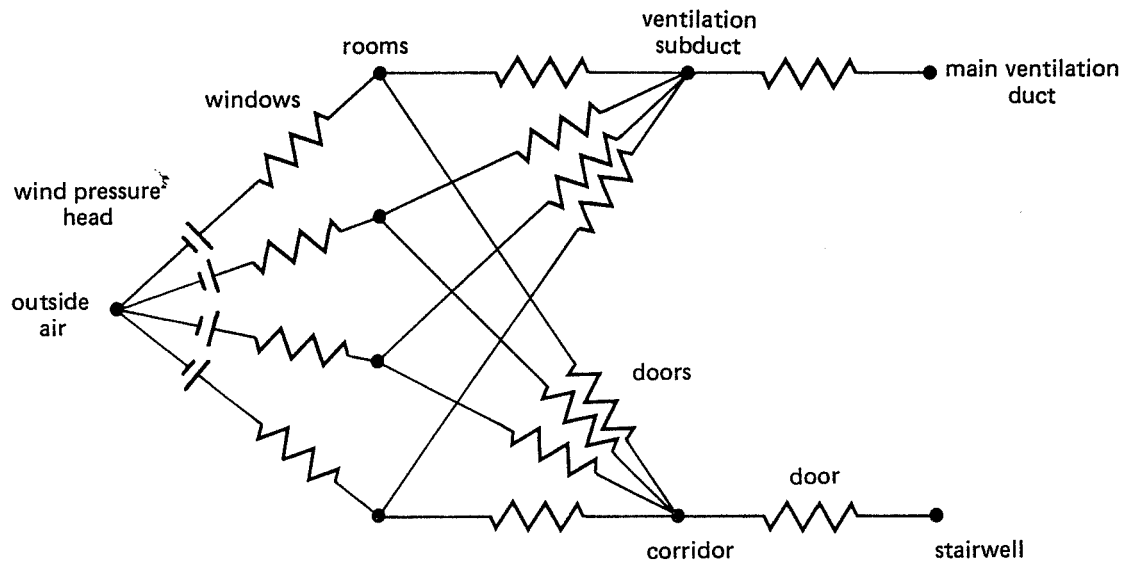

If there are  $p$  nodes which are part of internal vertical shafts, we replace the original network by a simplified one having  $(p + 1)$  nodes, one in each internal vertical shaft and one in the outside air, and a flow path between the outside and each of the  $p$  internal nodes. The simplified network is known as a  $(p + 1)$  terminal component.

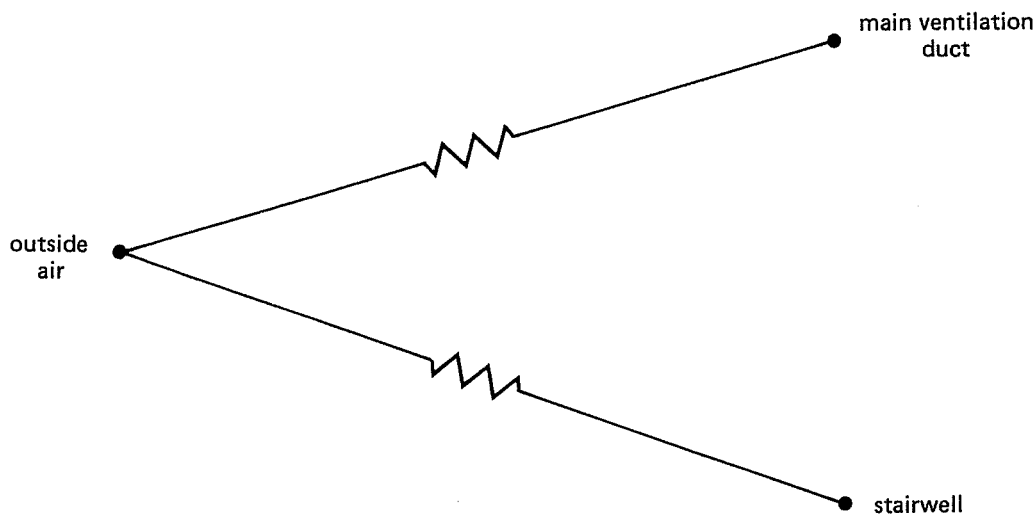

We generate a set of  $p$  linear terminal equations giving the relationship between the pressure difference and flow rate for each of the new artificial flow paths.

When we have calculated the terminal relations between the outside air and the vertical shafts on each floor, we join the floors together by the vertical shafts. The resulting simplified network is called the skeleton network.

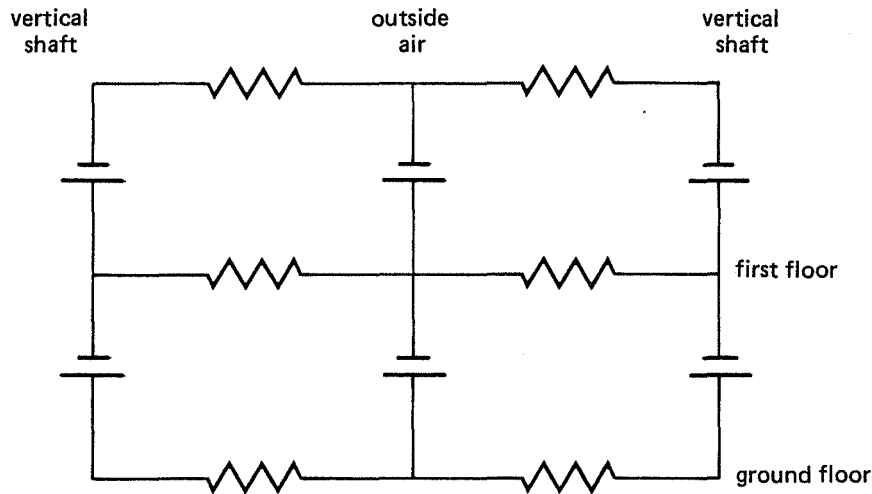

We solve this network to give the pressure difference and mass flow rate between the outside air and each shaft at all the floor levels. We then return to each floor in turn to obtain a complete solution for the original elements.

#### 4 THE STOCHASTIC ASPECTS OF THE SIMULATION

Fire operates in a stochastic environment. There are certain physical parameters which must be regarded as stochastic variables when calculating levels of risk in a particular building. The principal stochastic inputs to the calculation are the number of doors and windows left open, burnt down or broken, the ambient wind and temperature conditions and the location and severity of the fire. The variations in these parameters will considerably affect the rate of smoke spread through a building.

One of the objectives of this work is to be able to calculate the spread of hazardous or lethal concentrations of smoke from a fire in a building under different protective measures. Thus the program can provide for example comparative data for deciding the merits of different fire protection systems. In order to achieve this objective we must examine the effect of the variations in the stochastic environment on the spread of smoke through a building. The immediate objective of the work already completed has been to set up a mathematical model of the smoke spread, and to calculate the probability of the smoke density reaching certain specified levels in specified parts of the building at different times after the start of the fire. We envisage that the model will later be used to examine the relative importance of the effects on the smoke spread of the various stochastic parameters. These sensitivity analyses will clarify our understanding of the factors affecting smoke flow, and will be used in the design and evaluation of protective measures. The model may also be used as part of an extended model simulating the movement of people under threat. The output from this model would be the expected number of fatalities. These applications of the model are considered further in the final section of this report.

The program is designed to operate in either of two modes – deterministic or stochastic. In deterministic mode the user specifies values for all the stochastic variables. This mode is used to examine the spread of smoke caused by a particular type of fire in specified environmental conditions. In stochastic mode the values of the stochastic variables are sampled at random from specified statistical distributions. This mode is used to calculate risk levels in a building.

In order to calculate the probability of the smoke density exceeding certain levels, we use the method of Monte Carlo simulation. The simulation is performed a large number of times. At each pass, the values of the stochastic variables are sampled at random from their specified distributions. A range of values for the achieved smoke density at each node is observed.

If  $N$  is the total number of simulations performed and  $k$  is the number for which the smoke density  $C$  did not exceed the threshold level  $C_0$ , then the proportion  $k/N$  gives a direct estimate of required probability  $P(C \leq C_0) = p$ .  $k$  is distributed binomially with probability  $p$  of a success.

$$ie P(k = t) = \binom{N}{t} p^t (1 - p)^{N - t}$$

The estimator  $k/N$  for  $p$  is unbiased and has minimum variance. The standard error of this

estimate is  $\sqrt{\frac{p(1-p)}{N}}$ . If  $p$  is not very close to 0 or 1 and  $N$  is large enough,  $k/N$  is approximately normally distributed and we can obtain approximate confidence limits for  $p$ . If the fraction  $\gamma$  of the standard normal distribution is included between  $\pm b$  then the desired confidence limits for  $p$  are:

$$\frac{1}{1 + \frac{b^2}{N}} \left\{ \frac{k}{N} + \frac{b^2}{2N} \pm b \left[ \frac{\frac{k}{N} (1 - \frac{k}{N})}{N} + \frac{b^2}{4N^2} \right]^{\frac{1}{2}} \right\}$$

The probability that these limits define an interval which includes the actual value of  $p$  is approximately  $\gamma$ . This result indicates that in order to achieve a 95 per cent confidence interval about the value of  $p$  of  $\pm 0.1$  we require to perform about 100 simulations. Because of the amount of computation involved it is unlikely that we shall be able to perform more than this number of simulations.

If the anticipated value of  $p$  is close to 0 or 1 it may be economic to lay down, not the total sample size  $N$ , but instead to continue sampling until a specified number  $k$  of simulations result in a smoke concentration greater than the threshold level. The unbiased estimator for  $p$  is then  $\frac{k-1}{N-1}$ . The variance of this estimator is  $\frac{p(1-p)}{N-2}$ .

The actual level of smoke concentration reached in the specified parts of the building for each simulation is recorded. It is instructive to examine the probability density function (p.d.f) of the achieved smoke densities. The sample mean and variance

$$\left. \begin{aligned} \bar{C} &= \frac{1}{N} \sum_{i=1}^N C_i \\ S^2 &= \frac{1}{N-1} \sum_{i=1}^N (C_i - \bar{C})^2 \end{aligned} \right\}$$

are unbiased estimators of the mean and variance of the smoke density p.d.f. In addition we can examine the general form of the distribution function by plotting a histogram of the densities in the sample. At a later stage we may wish to fit a p.d.f to the set of observed densities.

The following variables are the stochastic parameters of the model:

- 1 Location of the fire
- 2 Temperature of the fire
- 3 Smoke concentration in the fire compartment
- 4 Ambient air temperature inside the building
- 5 Ambient air temperature outside the building
- 6 Wind speed
- 7 Wind direction
- 8 Number of doors open
- 9 Number of windows open
- 10 Time at which the door of the fire compartment burns down
- 11 Time at which the window of the fire compartment breaks.

The following parameters are also stochastic variables:

- 1 Size of cracks around doors
- 2 Size of cracks around windows
- 3 Reliability of the ventilation system.

The effect of the variations in these parameters is thought to be considerably less than that of the parameters already listed. The stochastic nature of these variables has therefore been initially neglected.

Some of the equations used to describe smoke spread contain constants whose values are uncertain; for example  $K_1$ ,  $K_2$  and  $K_3$  in the expressions for stratified flow along corridors. Experimental work is being conducted at the FRS to verify the values currently used in the model. In order to allow for this uncertainty these constants could be treated as stochastic variables with values sampled from specified distributions.

The statistical distributions used to describe the variations in the stochastic variables are given in Appendix A. In each case we give a reference indicating the source of the data. Owing to the difficulty in obtaining sufficient data within the timescale available many of the distributions are clearly very over simplified. In particular very few of the variables are assumed to be correlated, when in fact such correlations clearly exist.

For example the number of open windows will be highly correlated with wind speed. A considerable improvement in the representation of the stochastic environment can easily be effected when more data becomes available.

## 5 RESULTS

The model has been tested by examining the movement of smoke caused by fire in two example buildings. The two buildings chosen for this test were of two distinct design types. One, the main building at the Fire Research Station, is a comparatively low building with long corridors on each floor and two, well-separated staircases. The other, a simplified version of the new law courts in London, is a tall thin building with office accommodation built around a central core of services.

In the following sections we present some of the results obtained with the model in test runs with these two buildings.

### 5.1 The law courts

#### *The building*

The first example building is the new law courts building in London. We adopted a simplified plan of the layout of each floor and a simplified ventilation system, so that the data would not exceed the maximum size currently allowed for in the program. We chose this building because it exhibits many of the design features of a common type of modern tower



block. Also the Fire Research Station have already conducted some smoke tests in the building<sup>5</sup> and the results of these tests may be useful for model validation.

The simplified version of the building has five identical floors. The floor plan is shown in Figure 1. In the plan the building is 22.9 m square. The central core is approximately 9.1 m square and contains a staircase and three lifts. It is surrounded by a corridor (1.5 m wide) on each floor and the open plan office accommodation opens onto this. The parts of the corridor leading onto the staircase are formed into lobbies.

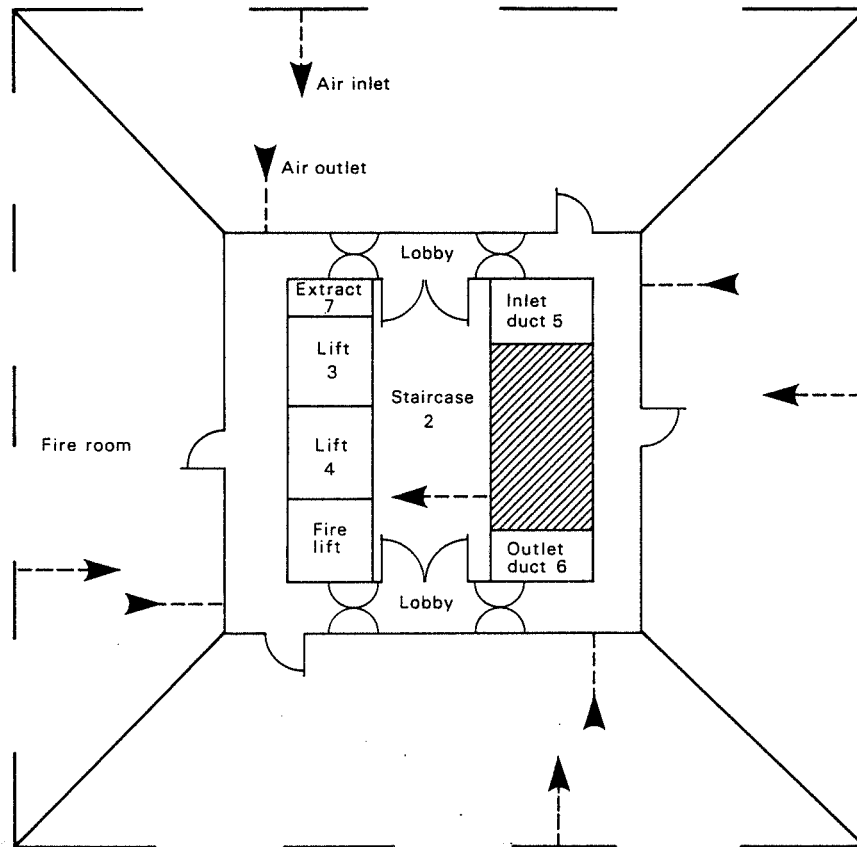

Figure 1 Simplified floor plan for the law courts

### *The ventilation system*

The windows of the building are sealed, and the interior accommodation is ventilated by an air conditioning system. Each room has a low level inlet grille, through which air is pumped into the room and a high level extract grille. All the openings from the office accommodation on each floor connect into two horizontal subducts, which in turn are connected to two vertical ducts, one for inlet and one for extraction of air. These vertical ducts have an opening of 0.1 sq m at the roof.

When a fire alarm is given the normal ventilation system is switched off, and the openings from the horizontal subducts to the vertical ventilation ducts on the floor at which the fire is detected are shut off. An emergency fan is brought into operation which supplies air at the rate of 0.5 kg/s to each floor on the central staircase. The objective of this is to maintain a higher pressure in the staircase than in adjoining spaces, so that the smoke will be excluded from the staircase.

Excess air leaves by grilles in the ceiling over the corridors and ultimately through a duct of cross sectional area 1.68 sq m which is open at the roof. This arrangement is not intended specifically for smoke removal, but in conjunction with the pressurised stair it should ensure that the drift will be away from the main staircase.

The simplified building has 18 nodes on each floor (including the outside air). Because both the fire lift and the staircase are closed at the roof and the only openings from the fire lift are onto the staircase, these two shafts may be considered together. Each room has 3 or 4 windows, and there are a total of 38 air flow paths to be considered on each floor. The building has 7 vertical shafts.

*The smoke test*

For the test run a fire was started in the room marked on the floor plan (Figure 1) on the second floor. The windows of the fire room were shut and the door was open. The temperature in the fire room was 1000°C and the concentration of smoke was 10\*. The ambient air temperature outside was 5°C and the ambient air temperature inside the building was 20°C. The wind was blowing directly into the windows of the fire room at a speed of 3.05 m/s. All the windows in the building were shut and about 1/3 of the inside doors were open, including 2 out of the 10 doors onto the main staircase. The normal ventilation system was switched off and the emergency pressurisation system was in operation.

*Results of the test*

Convergence of the flow network equations was achieved in 6 iterations through the building. Figure 2 shows the results for the mass flow rates (in kg/s) across all the flow paths

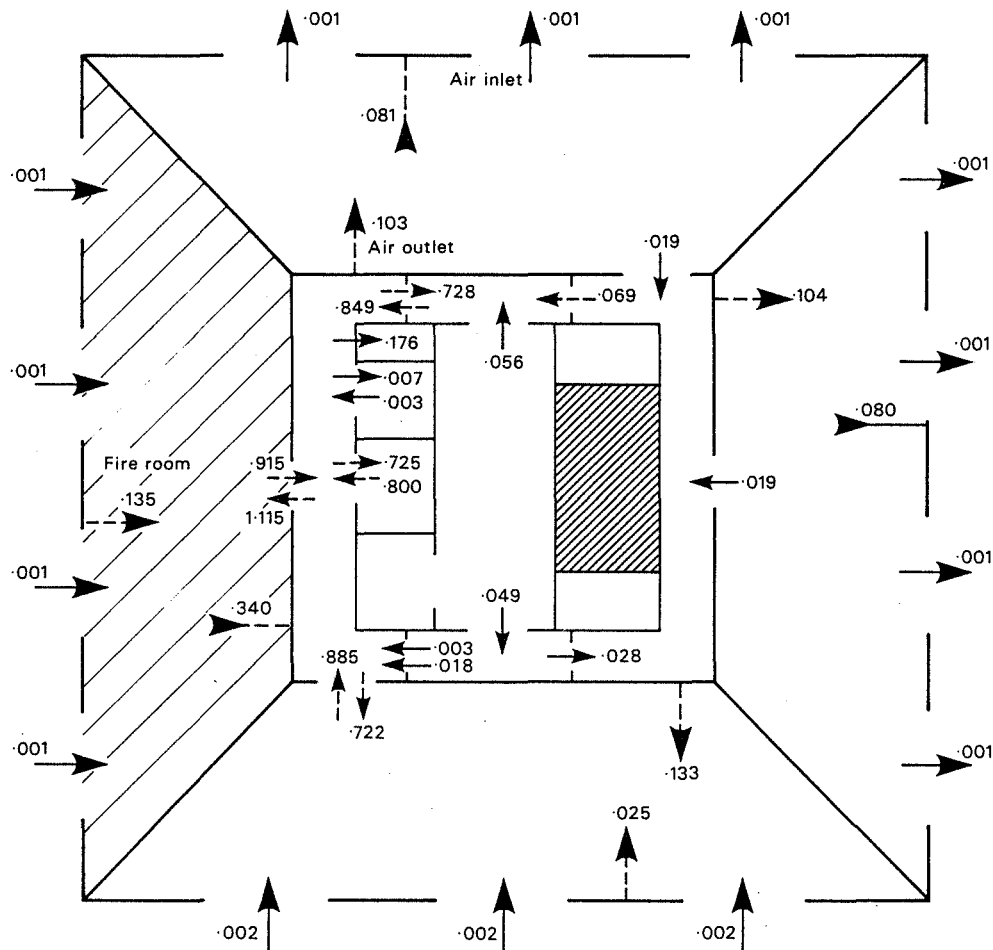

Figure 2 Mass flow rates across all flow paths on the fire floor

\*expressed as optical density per metre

on the fire floor. In the fire room itself and in the corridor outside the flow is stratified and air can flow in different directions through the top and bottom parts of the openings. The direction of the arrows indicate the direction of the flow. Doors which are open are shown with dotted arrows.

Figure 3 gives the mass flow rates (in kg/s) and pressure differentials (in  $N/m^2$ ) across all the flow paths leading on to the vertical shafts. This figure shows clearly the effectiveness of the pressurisation system as no smoke flows onto the central staircase.

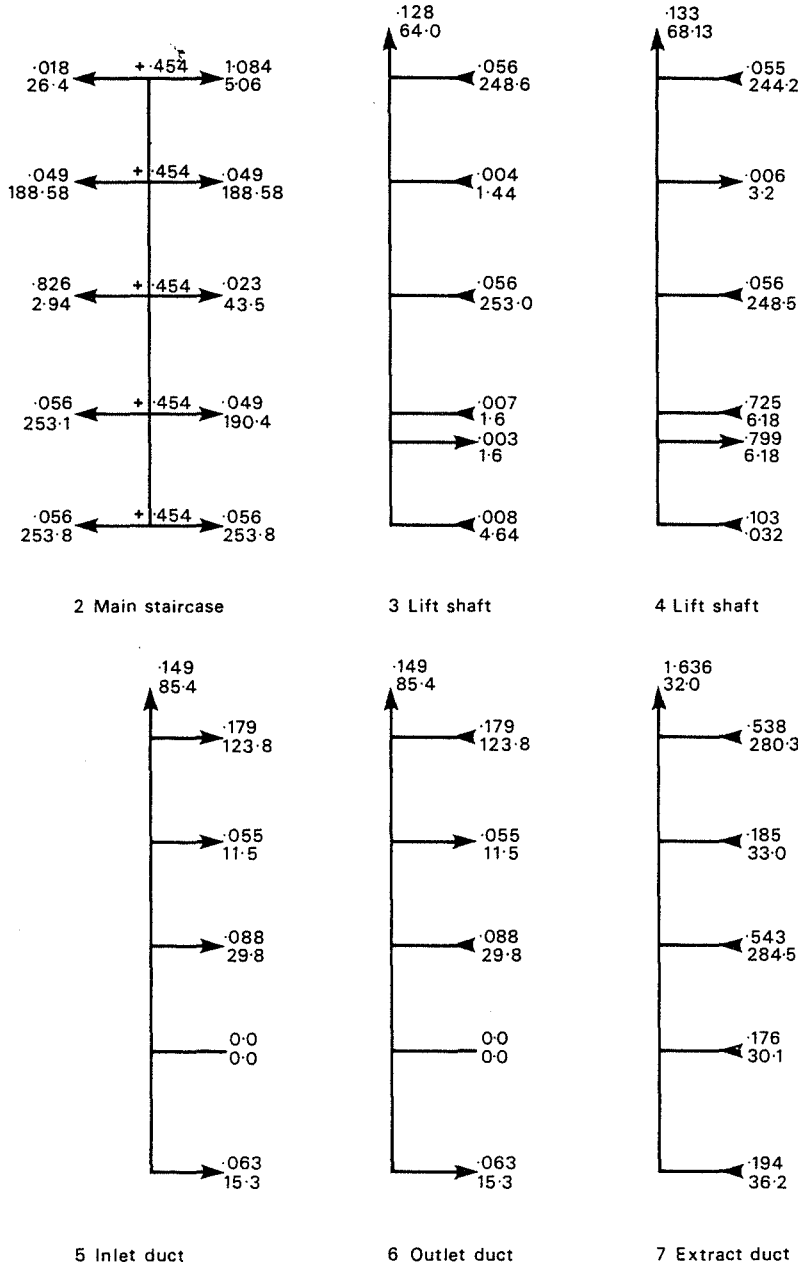

Figure 3 Mass flow rates (kg/s) and pressure differences ( $N/m^2$ ) across all the openings onto the vertical shafts in the law courts

The length of time taken for the smoke to form a layer under the ceiling in the corridor outside the fire room is 35 seconds and the concentration of smoke in this layer is 5. A large amount of smoke is drawn into the extract grille in the corridor ceiling and flows straight up through the extract duct and out through the roof. Some smoke does flow from the corridor through the open door into the Western lobby, but it does not permeate onto the staircase. In the fire room itself smoke is drawn into the extract duct of the normal ventilation system. This smoke flows along the horizontal subduct and emerges through the

ventilation ducts in all the other rooms on the fire floor. Because these horizontal subducts have been shut off from the main vertical ventilation ducts, no smoke can spread to other floors by this means. The only way in which smoke does spread onto other floors is through the lift shafts (3 and 4 on the diagram). The upflow of air in these shafts is however very small and it takes a long time for the smoke head to reach the upper floors. Most of this smoke flows out through the openings in the roof at the top of the shaft. After 15 minutes a small amount of smoke of concentration 1.7 emerges from shaft 4 on the fourth floor.

## 5.2 The Fire Research Station

### *The building*

The second example building used to test the model was the main building at the Fire Research Station. This building was chosen because it is of a completely different design from the previous example and detailed plans were readily available\*\*. The Fire Research Station has only three floors with long corridors on each floor. The main staircase is in the centre of the building and there is also a staircase at the end of the building. There is no mechanical ventilation system. Including all the lifts and ducts there are a total of seven vertical shafts. An outline plan of the building showing the positions of the shafts is given in Figure 4. All the lift shafts and the ducts are assumed to have a small opening at the roof. The building is divided into about 100 nodes and there are approximately 200 air flow paths.

### *The smoke test*

The fire was started in one of the small offices on the South side of the building on the ground floor. The fire temperature was 1000°C and the concentration of the smoke in the fire room was 10. Both the door and the window of the fire room were open. The wind speed was 1.52 m/s and the wind was blowing directly into the windows of the fire room. The ambient temperature inside and outside the building respectively were 20°C and 10°C. Approximately  $\frac{1}{4}$  of the windows were open and about  $\frac{1}{3}$  of the doors.

### *Results of the test*

Convergence of the flow network equations, to within the required degree of accuracy, was achieved in 5 iterations through the building. Figures 5, 6 and 7 show the results for the mass flow rates (in kg/s) across all the flow paths in the building. (Plans are not drawn to scale). The direction of the arrows indicates the direction of the flow. Open doors and windows are shown with dotted arrows. In the fire room the height of the neutral plane is calculated to be 1 m above the floor. This is below the level of the bottom of the window, so there is no inflow of air through the window.

Figure 8 shows the mass flow rates (in kg/s) along all the flow paths leading on to the vertical shafts.

The time taken for the smoke to form a layer under the ceiling in the corridor outside the fire room is calculated to be 4 minutes, and the concentration of smoke in this layer is  $\frac{1}{2}$  the initial concentration in the fire room. Smoke flows into all the vertical shafts. The direction of flow in all the shafts except one lift shaft and the main staircase is upwards. In the main staircase the window on the second floor is open and fresh air is flowing down the shaft, through the open door into the corridor outside the fire room. This air is the main supply of air for the fire room. So no smoke flows up the main staircase. However smoke does spread to the other floors by means of the second staircase, the second lift and the ventilation ducts. Most of this smoke emerges from the shafts on the second floor. The ventilation ducts are of relatively small cross sectional area and the time taken for the smoke head to reach the second floor is about 3 minutes. In the second staircase the flow rate up the shaft is small and it takes about 10 minutes for the smoke head to reach the second floor. The concentrations of the smoke emerging from the lift shaft, the staircase and the ducts are 4.0, 3.6 and 0.7 respectively.

---

\*\*The plans of the FRS used for this test were slightly out of date. The location of some of the doors and the number of vertical shafts is therefore not accurate for the building as it is in 1973.

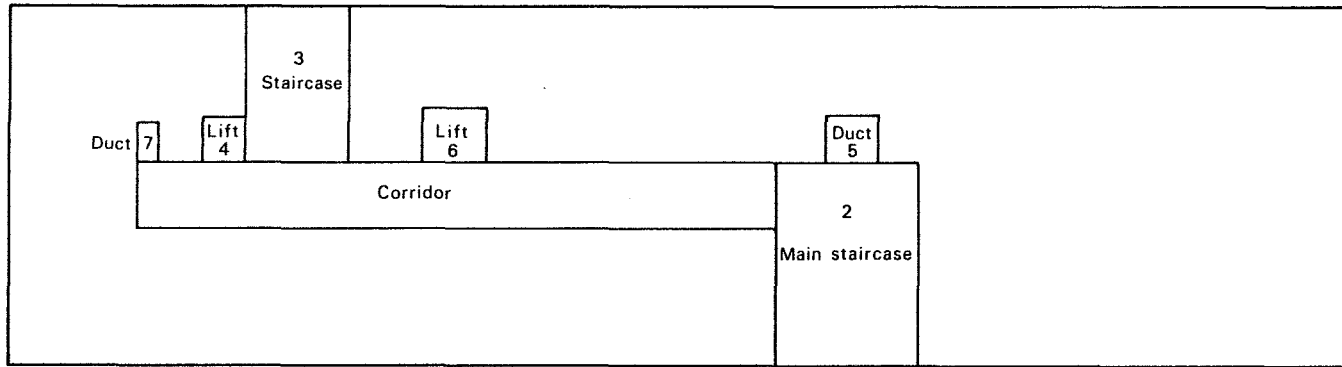

Figure 4 Outline plan of the Fire Research Station showing the vertical shafts

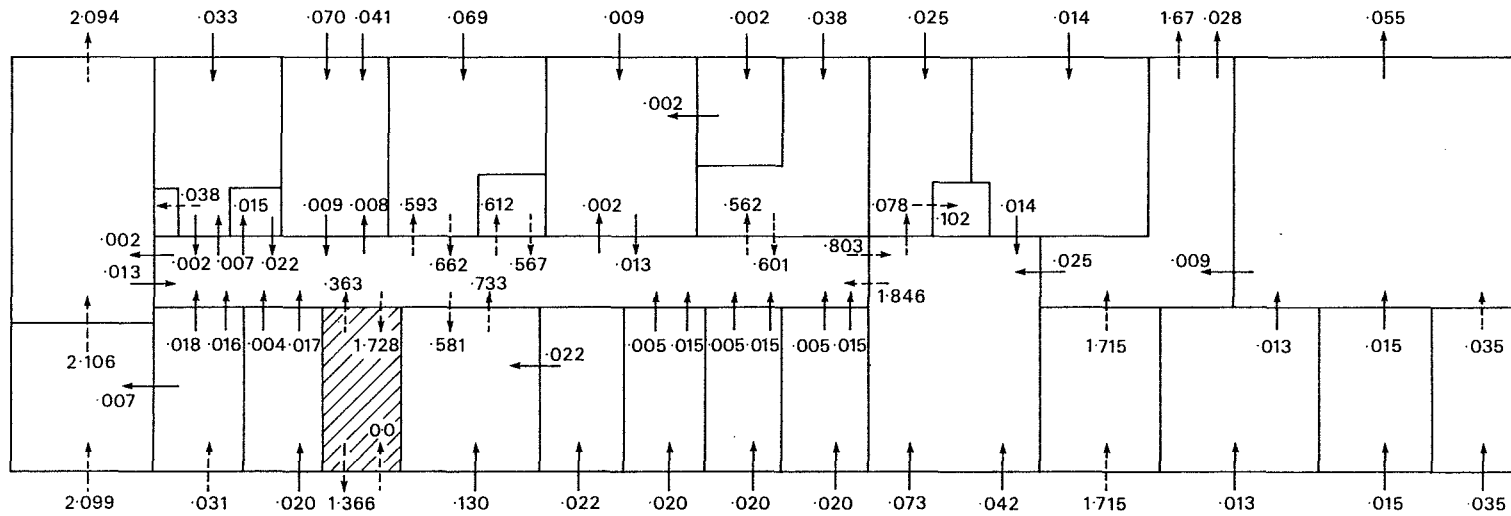

Figure 5 Mass flow rates on the ground floor of the Fire Research Station (kg/s)

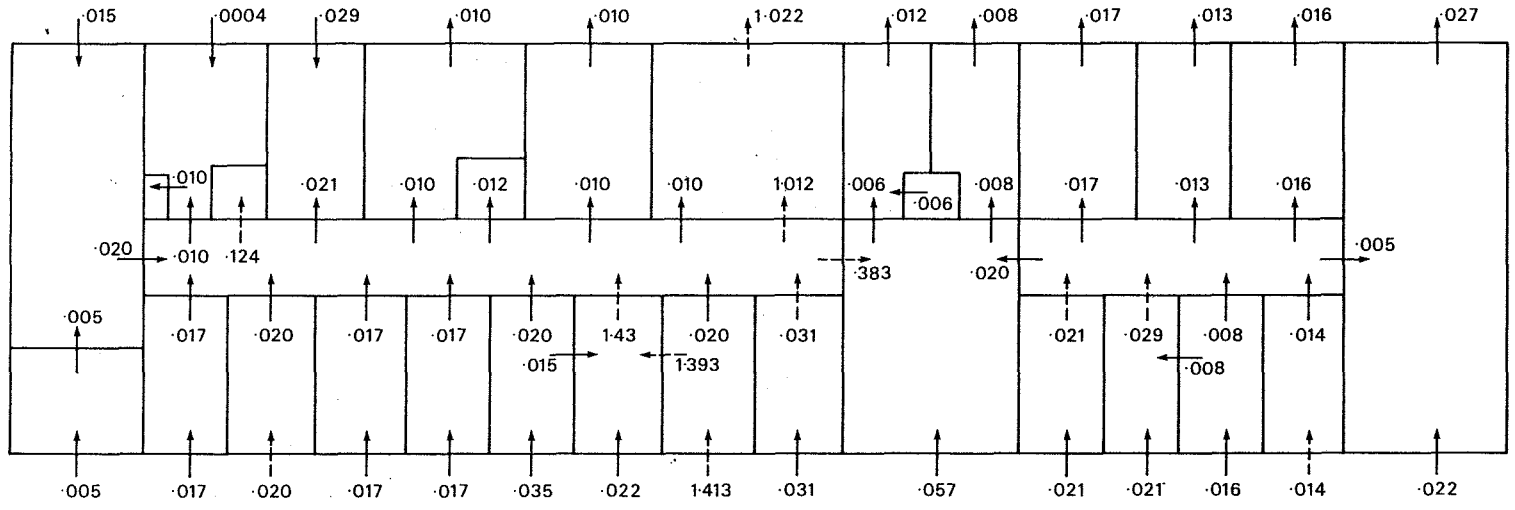

Figure 6 Mass flow rates on the first floor of the Fire Research Station (kg/s)

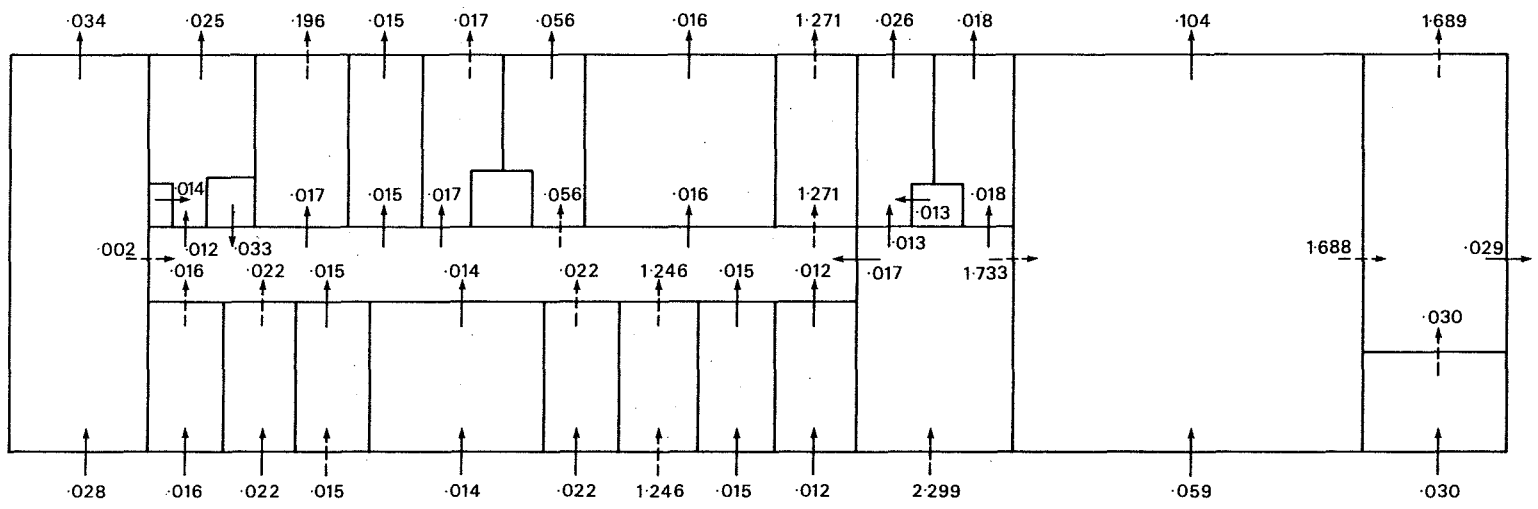

Figure 7 Mass flow rates on the second floor of the Fire Research Station (kg/s)

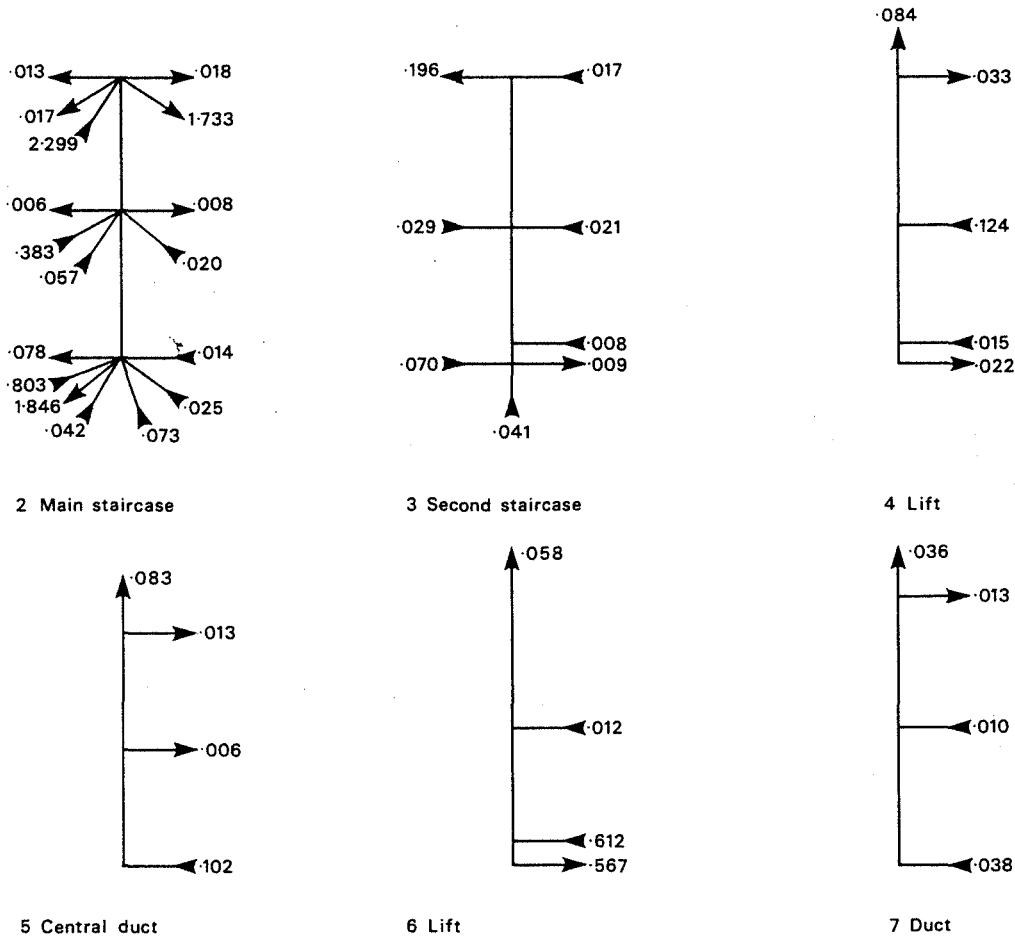

Figure 8 Mass flow rates into all the vertical shafts in the Fire Research Station (kg/s)

### 5.3 Discussion of results

We have presented here a sample of the results obtained with the model for the two example buildings. A preliminary analysis of the predicted smoke spread in the two buildings under a variety of conditions shows that, as expected, the most important factor affecting smoke spread in the FRS building is the wind combined with the number of doors and windows left open. In the law courts building, however, the dominant factor is the effect of the emergency pressurisation system.

The method used for the solution of the flow network equations seems to give a very efficient rate of convergence. For the tests described above convergence was demanded to an accuracy of about 0.004 kg/s in mass flow rate and 4.788 N/m<sup>2</sup> pressure difference. Convergence was then achieved in about 6 iterations through the building. More stringent convergence criteria have been successfully applied without increasing the required number of iterations beyond about 10. However, in some cases, if very stringent convergence criteria are demanded, an oscillation can develop in the solution which is outside these limits and convergence will not be recorded. However, because of the uncertainties involved in some of the approximations in the physical equations of motion, it is unnecessary to demand such great accuracy in the solution of the network equations.

Initially, another simpler method for solving the equations, using only the mass flow balance equation at each node, was tried. Although very economical in computer storage requirements, this method did not yield convergence under all conditions, so the method was not acceptable.

No quantitative data on smoke spread in buildings is currently available. Information is limited to general observations of smoke during fires and a few tests with cool smoke in certain buildings. Therefore it is difficult to give an accurate assessment of the validity of the physical equations of motion used in the model. These equations appear to yield sensible results, which agree with the information that is available. However there are several areas of the calculations where we feel that some further research is required.

One such area is the calculation of the height of the neutral axis in the fire room. In fact, the height of the neutral axis is different at each opening and depends on the pressure on the other side of the opening. Because of the approximation in all nodes of the building, except the fire room, that the pressure is constant throughout the node, we are only able to calculate one neutral plane in the fire room. Currently we have elected to calculate the neutral axis at the door and assume that this is the level of neutral plane right across the room. In most circumstances this is a reasonable approximation, but there may be situations in which it is not.

There is considerable uncertainty about the best equations to use to describe the flow in the corridor outside the fire room. Experiments are now being conducted by the FRS to verify the expressions currently used.

The other major area of concern is the expressions used to describe the flow in the vertical shafts. Very little is known about the circulations set up when hot gases enter a vertical shaft. We have neglected buoyancy forces in the shafts and consequently the rate of smoke spread to other floors is probably less than it should be. This calculation is clearly of great importance if the model is to be used to predict the time taken for remote areas of the building to become smoke logged. Therefore we believe that experimental work in this area should be given a high priority.

## **6 CONCLUSIONS AND RECOMMENDATIONS**

### **6.1 Conclusions**

We have described a method for calculating the movement of smoke caused by fire in a building, using a digital computer. Under the assumption of steady state conditions, the potential movement of smoke and its density can be calculated for any building.

Although the model is thought to give an adequate representation of the smoke spread, some experimental work is essential in order to validate the calculations\*, so that we can have sufficient confidence in the model to use it to make reliable predictions.

The model takes account of the stochastic environment in which fires occur. We recommend that it should be used for examining the important factors affecting smoke spread. Application is considered further in Section 6.2.

This technique will be a useful approach for evaluating alternative building constructional details and mechanical systems, during the design phase, so as to minimise the potential danger from smoke. Specific building features designed to provide safety from smoke during fires can be examined to determine their effectiveness. Some of the features which could be investigated include the use of smoke towers, smoke holes at the top of shafts, emergency ventilation and exhaust fan operation during fires, and the effect of rupturing windows. The technique can also be used to improve the design of the escape routes in a building.

---

\*(Validation work is in progress at FRS and will be reported in due course)



The model can be applied to the problem of determining the natural ventilation flows through a building, in the absence of a fire.

The program has been set up to run for any building. The only restrictions being the maximum number of subdivisions and flow paths allowed. Many factors affect the cost of an analysis for any single building. These factors include building size, complexity and type of ventilating and air conditioning system. The preparation of the data for a building of complex layout represents a major proportion of the cost.

## 6.2 A programme of future work

### *Sensitivity analysis*

Until recently little research has been done into the factors affecting smoke movement in buildings. In order to be able to design protective measures which will be effective against the potential dangers from smoke during fires, we require to improve our understanding of the important factors affecting the rate of smoke spread. Fire occurs in a stochastic environment. For example the number of doors and windows left open, and the prevailing wind conditions can considerably alter the risk to occupants of a building. We need to examine the effect of the stochastic environment on the smoke spread.

We propose that one of the first applications of the model which has been developed, should be a general study, or sensitivity analysis, to examine the relative importance of the principal factors which can affect the smoke spread. The factors which need to be investigated include:

- 1 Temperature difference between inside and outside the building
- 2 Temperature of the fire
- 3 Wind speed
- 4 Wind direction
- 5 Location of the fire
- 6 Number of open doors
- 7 Number of open windows
- 8 Whether the door of the fire compartment is open
- 9 Whether the window of the fire compartment is open

The study could also examine the relative effect on the smoke spread of existing protective techniques such as pressurisation. The effects of all the factors listed above are not independent. For example the effect of a high wind on the smoke spread will clearly depend on the number of open doors and windows. The aims of the study should be to consider the effect of the individual parameters, determine those which are most important and to examine the interactions between the effects of different parameters.

It is desirable to conduct a general study, designed to lead to general conclusions, not related to a particular building. However the rate of smoke spread predicted by the model is highly building dependent. Therefore it is necessary to categorise buildings into design types and repeat the experiments for each category, so as to draw general conclusions for that category. For example we might consider initially two building types such as described in the results section of this report – high rise buildings with a central core of services, and long low buildings with several main staircases.

We recommend that the best means of conducting such a study with the resources available is by a fractional factorial experiment. In a factorial experiment the effects of all the factors can be investigated simultaneously. Each factor is allotted several levels (usually two – a high level and a low level). Possible levels for the factors under consideration are:

- 1 Temperature difference : 0 and 10°C
- 2 Fire temperature : 800°C and 1200°C
- 3 Wind speed : 0 and 6.1 m/s
- 4 Wind direction : directly into and out of the fire room windows
- 5 Fire location : near the top and bottom of the building
- 6 Open doors : probability of doors being open = 0.25 and 0.75
- 7 Open windows : probability of windows being open = 0.25 and 0.75
- 8 Fire door : open and shut
- 9 Fire windows : open and shut
- 10 Emergency ventilation system : on and off

In a full factorial experiment the treatments would consist of all combinations that can be formed from all the factors at the different levels.

The 'main effect' of each factor is defined to be the effect of increasing it from the low level to the high level averaged over all possible combinations of the other factors. The first order interaction between factors A and B is defined to be the difference between the effect of increasing A, when B is at the high level, and the effect of increasing A, when B is at the low level, averaged over all possible combinations of the remaining factors. High order interactions can be defined similarly. A full factorial design to examine 10 factors each at two levels required  $2^{10}$  experiments and enables all the main effects and interactions up to the tenth order to be estimated. Clearly this number of experiments is impossible when examining smoke spread because of the cost of each experiment (ie of each simulation).

Often it is possible for an experimenter, with an inherent understanding of the system under study, to neglect a considerable proportion of the higher order interactions in comparison with the main effects and the low order interactions. This assumption enables us to examine the low order interactions by conducting a much smaller number of experiments using a fractional factorial design. With a fractional factorial design we perform only a small proportion of the experiments of the full factorial design. By ignoring suitable higher order interactions we can determine which experiments are needed in order to estimate all the required low order interactions. Great care must be taken in deciding which interactions can safely be neglected. The neglect of a truly significant interaction can lead to severe misinterpretation of the results.

We have mentioned ten factors which affect the smoke spread. In order to be able to estimate the main effects and all the first order interactions (as well as some of the higher order interactions) of these factors, we require to perform 128 simulations for each category of building. This represents an  $\frac{1}{8}$  replicate of the full factorial design, and from cost considerations is about the maximum number of experiments we could hope to perform. Most of the higher order interactions would have to be neglected.

With values specified for the factors as given above, the only stochastic element of the simulation is which doors and windows are open for each experiment. With 128 experiments in all, each main effect is estimated as an average over 64 combinations of other factors. Similarly the first order interactions are estimated as an average over 32 combinations. This degree of replication is thought to be sufficient to take account of the stochastic element.

In order to adopt this approach we need some measure of the effect on the smoke spread of the different treatments. The results of each treatment could be considered a vector of the smoke densities attained either at specified nodes or at all nodes. A more satisfactory result to consider would be the number of building nodes which had become smoke logged after a certain time.

The objective of this study is to further our general understanding of the relative importance of the factors affecting smoke spread in buildings. A fractional factorial design is particularly useful for this type of experiment, where the aims are of an exploratory nature. Once an important factor has been discovered, detailed work on that factor can follow. The fractionally replicated design is of value because a large number of effects and low order interactions can be estimated from a relatively small number of experiments. The hazards of the technique are that it is essential, before conducting the experiment, to neglect many of the higher order interactions. If some interactions that have been assumed negligible are not so, considerable misinterpretation of the results can occur. Nevertheless, because of the exploratory nature of this work, we believe that this type of experiment is the most efficient means of improving our understanding with the resources available to us.

#### ACKNOWLEDGEMENT

We should like to thank Dr P H Thomas, Mr P L Hinkley and Mr A J M Heselden, all of the Fire Research Station for their help in defining the equations of motion to describe the movement of smoke through buildings, and for their useful comments during the preliminary analysis of the results. We should also like to thank Mr R Baldwin of the Fire Research Station for his help in gathering data for the stochastic elements of the simulation.

#### REFERENCES

- 1 **Hobson P J and Stewart L J.** Pressurisation of escape routes in buildings. Fire Research Station, Fire Research Note 958, Borehamwood 1972.
- 2 **Wakamatsu, T.** Smoke protecting design system and smoke behaviour in buildings. Problems of automatic fire detection. Technischen Hochschule, Aachen (October 1971).
- 3 **Wakamatsu T.** Calculation of smoke movement in buildings. First report. Japan Ministry of Construction, Building Research Institute, Research Paper 34, Tokyo (August 1968).
- 4 **Hinkley P L and Heselden A J M.** SCICON program – Initial conditions. Fire Research Station, unpublished data (June 1973).
- 5 **Butcher E G and Hall M.** Smoke tests in the new law courts building. Fire Research Station, Fire Research Note 889, Borehamwood 1971.
- 6 **Kibblewhite B and Stewart L J.** A survey of the thermal environment in naturally ventilated offices in summer. Heating and Ventilating Research Association, Laboratory Reports No 31, Feb 1966 and No 34, Oct 1966.
- 7 **Institute of Heating and Ventilation Engineers.** IHVE Guide, Book A, 4th Edition. London 1970.
- 8 **Meteorological Office.** Surface wind speed and direction (UK). Reference 792, 40–177.

## APPENDIX A: STATISTICAL DISTRIBUTIONS USED TO DESCRIBE THE STOCHASTIC PARAMETERS OF THE SIMULATION

In this appendix we give the statistical distributions used to describe the stochastic parameters of the simulation. In each case we indicate the source from which the data was obtained.

**(i) Location of the fire**

The fire is equally likely to start in any of the rooms in the building. No fires start in corridors or in vertical shafts. All the data for the parameters describing the fire itself was provided by Mr R Baldwin of the Fire Research Station.

**(ii) Temperature of the fire**

We are solely concerned, at this stage, with ventilation controlled fires. The temperature of the fire if sampled from a triangular distribution with minimum value  $800^{\circ}\text{C}$ , maximum value  $1200^{\circ}\text{C}$  and mode  $100^{\circ}\text{C}$ .

**(iii) Smoke concentration**

The concentration of smoke in the fire room is triangularly distributed with minimum value 5, maximum value 20 and mode 10. This parameter is not very important because it is usually satisfactory to measure simply the dilution of the smoke which has occurred since leaving the fire room.

**(iv) Inside temperature**

The ambient air temperature inside the building is normally distributed<sup>5</sup> with mean  $22.8^{\circ}\text{C}$  and standard deviation  $2.3^{\circ}\text{C}$ . The inside temperature is independent of summer and winter conditions, but must always be greater than the external temperature.

**(v) Outside temperature**

The ambient air temperature outside the building is uniformly distributed between maximum and minimum values<sup>7</sup> of  $20^{\circ}\text{C}$  and  $0^{\circ}\text{C}$ .

**(vi) Wind speed**

The wind speed has a normal distribution<sup>8</sup> with mean 16.1 km/h and standard deviation 5.3 km/h.

**(vii) Wind direction**

The wind direction has a multi-normal distribution with modes  $60^{\circ}$  and  $240^{\circ}$  E of N and standard deviations  $20^{\circ}$  and  $40^{\circ}$ . The probabilities of the wind direction being around  $60^{\circ}$  and  $240^{\circ}$  are 0.3 and 0.7 respectively<sup>8</sup>

**(viii) Open doors**

All doors are assumed to be either fully open or fully closed. Inside and outside doors both have a probability of 0.38 of being open. The data on open doors was collected by Mrs S Coward of the Fire Research Station.

**(ix) Open windows**

Similarly all windows are assumed to be either fully open or fully closed. If the outside temperature is less than  $10^{\circ}\text{C}$  winter conditions are assumed to prevail. In summer windows have a probability of 0.25 of being open. In winter the probability is 0.05. No satisfactory data on open windows was available so these figures represent a 'best guess'.

**(x) Door burning down**

The time taken for the door of the fire compartment to burn down is greater than the timescale over which calculations are currently performed. So this parameter has been initially neglected.

(xi) Window breaking

The probability of the window in the fire room breaking as a result of the heat is 0.9. If the window breaks it is assumed to break immediately at flashover of the fire.

**APPENDIX B: SMOKE CONCENTRATION IN A GENERAL COMPARTMENT**

Consider a node with an opening directly to a vertical shaft. Let  $C_1$  be the smoke concentration at that node. Then, with the notation of Section 2.10 of this report,  $C_1$  is given by:

$$C_s Q_s - C_1 \Sigma Q_1 = \rho V_1 \frac{dC_1}{dt}$$

$$\frac{dC_1}{dt} + C_1 \frac{\Sigma Q_1}{\rho V_1} = \frac{C_s Q_s}{\rho V_1}$$

The solution to this equation is:

$$C_1 e^{\frac{\Sigma Q_1}{\rho V_1} (t - T_s)} = \frac{C_s Q_s}{\Sigma Q_1} \left\{ e^{\frac{\Sigma Q_1}{\rho V_1} (t - T_s)} - 1 \right\}$$

Therefore  $C_1 = \frac{C_s Q_s}{\Sigma Q_1} \left\{ 1 - e^{-\frac{\Sigma Q_1}{\rho V_1} (t - T_s)} \right\}$

If smoke flows into the node from a vertical shaft through another node and  $C_1$  and  $C_2$  are the concentrations at the intermediate node and the specified node respectively, there, with the notation of 2.10,  $C_2$  is given by:

$$\rho V_2 \frac{dC_2}{dt} + C_2 \Sigma Q_2 = \frac{Q_r C_s Q_s}{\Sigma Q_1} \left\{ 1 - e^{-\frac{\Sigma Q_1}{\rho V_1} (t - T_s)} \right\}$$

$$\frac{dC_2}{dt} + C_2 \frac{\Sigma Q_2}{\rho V_2} = \frac{Q_r C_s Q_s}{\rho V_2 \Sigma Q_1} \left\{ 1 - e^{-\frac{\Sigma Q_1}{\rho V_1} (t - T_s)} \right\}$$

The solution to this equation is:

$$C_2 = \frac{C_s Q_s Q_r}{\Sigma Q_2} \left\{ \frac{1}{\Sigma Q_1} \left( 1 - e^{-\frac{\Sigma Q_1}{\rho V_1} (t - T_s)} \right) + \frac{e^{-\frac{\Sigma Q_2}{\rho V_2} (t - T_s)} - e^{-\frac{\Sigma Q_1}{\rho V_1} (t - T_s)}}{\left( \frac{\Sigma Q_2}{\rho V_2} - \frac{\Sigma Q_1}{\rho V_1} \right) \rho V_1} \right\}$$