

ROYAL INSTITUTION  
OF GREAT BRITAIN

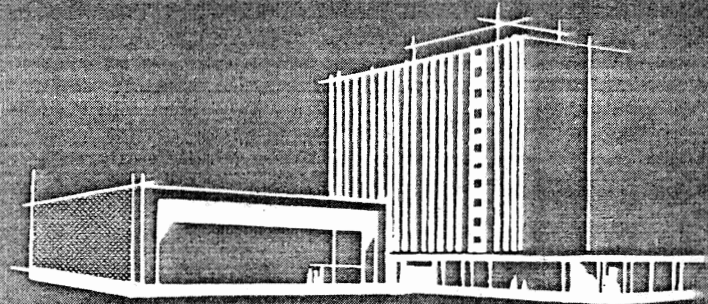

## NBS BUILDING SCIENCE SERIES 57

U.S. DEPARTMENT OF COMMERCE / National Bureau of Standards



# Comparison of Measured and Computer-Predicted Thermal Performance of a Four Bedroom Wood-Frame Townhouse



# Comparison of Measured and Computer-Predicted Thermal Performance of a Four Bedroom Wood-Frame Townhouse

---

B. A. Peavy, D. M. Burch,  
F. J. Powell, and C. M. Hunt

Building Environment Division  
Institute for Applied Technology  
National Bureau of Standards  
Washington, D.C. 20234

Sponsored by

Department of Housing and Urban Development  
451 7th Street, S.W.  
Washington, D.C. 20410

and

National Bureau of Standards  
Washington, D.C. 20234



---

U.S. DEPARTMENT OF COMMERCE, Frederick B. Dent, *Secretary*  
NATIONAL BUREAU OF STANDARDS, Richard W. Roberts, *Director*

Issued April 1975

**Library of Congress Cataloging in Publication Data**

Main entry under title:

Comparison of Measured and Computer-Predicted Thermal performance of a Four Bedroom Wood-Frame Townhouse.

(NBS Building Science Series; 57)

Sponsored by U.S. Dept. of Housing and Urban Development and National Bureau of Standards.

Supt. of Docs. No.: C 13.29/2:57

1. Wooden-frame houses—Heating and ventilation. 2. Wooden-frame houses—Air conditioning. 3. Wooden-frame houses—Testing. 4. Wooden-frame houses—Thermal properties. I. Peavy, Bradley A. II. United States. Dept. of Housing and Urban Development. III. United States. National Bureau of Standards. IV. Series: United States. National Bureau of Standards. Building Science Series; 57. TA435.U58 No. 57 [TH7341] 690'.08s [697] 74-20830

**National Bureau of Standards Building Science Series 57**

Nat. Bur. Stand. (U.S.), Bldg. Sci. Ser. 57, 62 pages (Apr. 1975)

CODEN: BSSNBV

U.S. GOVERNMENT PRINTING OFFICE  
WASHINGTON: 1975

---

For sale by the Superintendent of Documents, U.S. Government Printing Office, Washington, D.C. 20402  
(Order by SD Catalog No. C13.29/2:57). Price \$1.20.  
Stock Number 0303-01364

## Contents

	Page
1. Introduction .....	1
2. Prediction and evaluation analysis .....	2
3. Description of the test house .....	4
4. Instrumentation and transducers .....	10
5. Experimental methods and conditions .....	13
5.1. Simulated outdoor weather cycles .....	13
5.1.1. Macon, Georgia .....	13
5.1.2. Kalamazoo, Michigan (Battle Creek) .....	15
5.2. Simulated occupancy .....	16
5.3. Internal mass of test house .....	20
5.4. Performance of HVAC system components .....	21
5.4.1. Air distribution system .....	21
5.4.2. Air cooling unit .....	22
5.4.3. Gas-fired furnace .....	22
5.5. Thermal and physical properties .....	24
5.6. Description of tests .....	26
5.6.1. Description of winter tests .....	26
5.6.2. Description of other tests .....	26
6. Results and discussion .....	27
6.1. Winter heating tests .....	27
6.2. Summer cooling test .....	31
6.3. Fall test .....	32
6.4. Comparison summary of predicted and measured energy consumption .....	33
6.5. Pull-down test .....	33
6.6. Nighttime setback tests .....	34
6.7. Steady-state winter test .....	36
6.8. Temperature distribution during winter tests .....	38
6.9. Mean radiant temperature .....	41
6.10. Humidity analysis .....	42
7. Conclusions .....	44
8. Nomenclature and conversion factors .....	44
9. References .....	46
Acknowledgment .....	46
Appendix A—Air infiltration measurements on the four-bedroom townhouse .....	47
Appendix B—Interior noise levels in the four-bedroom townhouse .....	51
Appendix C—Mathematical simulation of the test house .....	55

# Comparison of Measured and Computer-Predicted Thermal Performance of a Four-Bedroom Wood-Frame Townhouse

B. A. Peavy, D. M. Burch, C. M. Hunt, and F. J. Powell

Measurements of the dynamic heat transfer in a four-bedroom townhouse were made under controlled conditions in a large environmental chamber to explore the validity of a computer program developed at NBS, labelled NBSLD, for predicting heating and cooling loads and inside air temperatures. This study was supported jointly by the Department of Housing and Urban Development and the National Bureau of Standards, and is a part of a broader research program supported by both agencies to improve performance test procedures and criteria for housing.

The test house was a factory-produced four-bedroom townhouse of modular design and of lightweight (wood) construction. Tests were performed with simulated outside summer, winter, and fall diurnal temperature cycles. The inside temperature was maintained at about 75 °F. Also during the tests, the activities of a six-member family were simulated.

The time-varying energy requirements were measured, and these values were compared with computer predicted values. For example, the disparity between predicted and measured daily heating energy requirements averaged 3.1 percent with a maximum departure of 4.9 percent for five tests. The computer program NBSLD was experimentally validated for predicting the peak heating and cooling loads and the energy requirements for the test house.

The air leakage of the house was measured by a tracer gas technique over a range of outdoor conditions, and algorithms were developed to account for its effect on heating loads and energy requirements.

Separate tests were also performed to investigate the energy savings achieved by night temperature setback. An 8-h 9 °F setback from 75 °F produced an 11 percent diurnal savings in energy for an average nighttime temperature of 20 °F and a 9 percent savings in energy was achieved for the same setback when the average nighttime temperature was 2 °F.

Key words: Air leakage measurement; building heat transfer; computer programs; dynamic thermal performance; heat flow analysis; heating and cooling loads; temperature predictions; thermal analysis; thermostat setback; transient heat flows.

## 1. Introduction

The indoor thermal environment of a building is influenced by the weather, by the thermal behavior of the walls, roof, and floor, by heat-producing occupancy-related activities and especially by the mechanical, electrical and service systems that must function to provide control of heating and cooling devices that serve to make living spaces more habitable. To provide a functional and habitable indoor thermal environment for occupants within a building requires careful consideration of the properties and performance of the materials that comprise the

building envelope together with careful design, specification and installation of its mechanical and electrical systems.

The building materials and systems taken together are a major cost of the building in-place. In addition, the operating and maintenance costs for a building such as fuel and power for heating, cooling, and lighting plus labor costs can make the long-term investment large. A small impact in any of these areas can pay long-term dividends and at the same time help our nation conserve its energy resources.

In order to accomplish savings, it is necessary that the architect and engineer be provided with

reliable techniques and methods for predicting and evaluating the energy utilization for the building. An energy analysis should be capable of providing hourly, daily, and seasonal system performance data and it must preferably be based on dynamic conditions reflecting the changing patterns of weather and climate and the time-dependent interactions within the building itself. Such an approach requires a very large number of calculations. The digital computer allows an engineer to rapidly and inexpensively calculate: (a) energy requirements with consideration of operating costs, (b) heating and cooling load profiles for equipment design or selection and operation, (c) information needed to rapidly evaluate a large number of options in the design process, (d) optimum energy utilization and (e) the need for zoning in large buildings.

The Thermal Engineering Systems Section at NBS has developed a comprehensive computerized mathematical model called National Bureau of Standards Load Determination Program [1],<sup>1</sup> NBSLD, which when taken with simulations of the building's mechanical and electrical systems and economics routines allows a complete energy analysis.

Computer programs usually contain engineering approximations that require experimental verification before being adopted for wide-scale use. In addition, the performance data on building materials and elements, design weather data and boundary conditions at surfaces need specific definition to assure accuracy of predicted results. An example is the lack of reliable data on air infiltration rates into buildings which may account for as high as one-third of the heating or over 40 percent of the cooling load for a building. A previous study [2] was completed on an experimental masonry building where the fabric of the building was altered to determine the thermal response of the building and to validate the computer program NBSLD when used on heavyweight construction.

This study, cosponsored by the Department of Housing and Urban Development (HUD) and the National Bureau of Standards (NBS), explores the actual dynamic flow of heat into and out of the fabric of a lightweight building made of wood and the resulting temperature patterns of the indoor air and the structure itself when the indoor air

temperature was controlled by a thermostat. The objectives of this study were: (1) to measure time-varying heating and cooling energy consumptions for a full-scale test house subjected to changing simulated weather patterns in the laboratory and to compare these values with corresponding computer-predicted values, and (2) to experimentally measure the internal environment with respect to temperature distribution, air infiltration, mean radiant temperature, relative humidity, and the performance of the heating and cooling system. Experiments were performed under controlled conditions in a large (70,000 ft<sup>3</sup>) environmental chamber at NBS capable of controlling temperature and humidity over the range -50 to 150 °F.

For the series of tests discussed in this paper, a full-scale house was purchased using the performance specifications developed by NBS for HUD Operation BREAKTHROUGH. The four-bedroom townhouse of lightweight (wood) construction was factory produced in three modules or units. It was transported to NBS on flat-bed trailers and installed in the environmental chamber. The first floor consisted of two modules and contained the kitchen, dining room, living room, two bedrooms and a bathroom. The second floor (third module) consisted of two bedrooms and a bath and was placed above the module containing the kitchen. The townhouse was designed to be the end unit of a row of townhouses. The house was suitably furnished for a family of six. During the tests normal living activities of a family of two adults and four children were simulated. Weather patterns for the summer and winter of cold and warm climates were imposed on the house.

In conjunction with the experimental phases involving thermal performance, two other significant experiments were performed on the test house. The first experiment was concerned with the air infiltration rate. The method, procedure, and results are contained in appendix A of this paper. The second experiment involved a series of noise level measurements and the method, procedure, and results are presented in appendix B.

## 2. Prediction and Evaluation Analysis

In using the NBS Load Determination Computer Program, it is necessary to provide as

<sup>1</sup> Figures in brackets indicate the literature references on page 46.

input the outdoor weather conditions, the construction details of the building (such as a layer by layer description and the heat transfer areas of the exterior facing walls, roof, and floor, its orientation, etc.), and the building operating schedule for equipment, lighting, and occupancy. The algorithms of the computer program operate on this input data in such a manner as to predict either inside air temperature or heating and cooling loads. A simplified flow chart of the computer program is given in figure 1. The computer algorithms used in NBSLD are given in detail in [1]. In summary, the prediction procedure contains:

- Item 1. Derived expressions for converting outside environmental conditions and weather elements, such as dry- and wet-bulb temperature, incident solar radiation, wind velocity, etc., into forms useful for quantifying the heat transfer phenomena.
- Item 2. A comprehensive system of mathematical expressions or algorithms for solving dynamic heat transfer problems dealing with conduction, convection, and thermal radiation. These algorithms apply to heat transfer as related to walls, windows, roofs, floors, surrounding earth, and the internal mass of a building such as the furniture, partitions, and equipment.
- Item 3. Expressions for air infiltration and ventilation rates based on information given in the literature and on current experimental work.
- Item 4. Algorithms for the time-dependent thermal interactions taking place within a building, such as human occupancy, occupancy related activities, and process heat generating functions.

For this work the algorithms of Item 1 were not needed because the outdoor air temperatures as a function of time were purposely defined, controlled and measured in the laboratory. The algorithms for Item 2 employ the Response Factor method which predicts one-dimensional heat flow in building components by utilizing the superposition principle in such a manner that the overall thermal response of a component at a selected

time is the sum of the responses caused by many individual temperature or heat flux pulses during previous time steps. The theory and applications of this method are discussed in detail in appendix C. These algorithms were used extensively for the prediction aspects of this paper. For Item 3, infiltration of air from the outside to the inside was considered to be approximated by the simple relationship

$$I = A + B\Delta T + CW$$

where  $I$  is the air change rate,  $\Delta T$  is the temperature difference between the inside and outside air temperature,  $W$  is the outside air velocity, and  $A$ ,  $B$ , and  $C$  are constants. Values for  $A$ ,  $B$ , and  $C$  are given in [4] and were also determined experimentally on the test house. For Item 4, algorithms were developed for determining the heat generation due to the time-dependent activities of occupants and related processes.

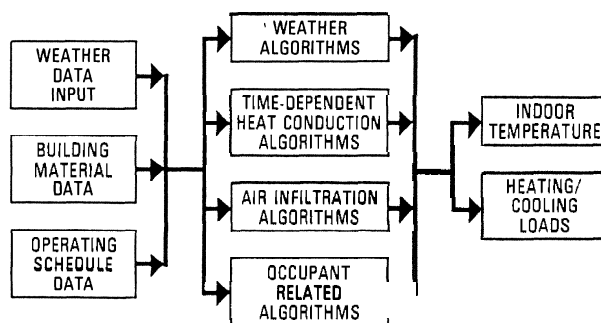

FIGURE 1. Simplified flow chart of NBS load determination computer program.

For the test house, safe, reliable and comfortable heating and cooling control should be provided for all occupied spaces. To attain these conditions certain performance guidelines or criteria were established and then the house was measured in the laboratory. In general, these criteria are that the heating, ventilating, and air-conditioning system should provide:

1. Adjustable automatic means for control of temperature in the house to within  $\pm 2$  °F at the point of control for any indoor temperature between 65 and 80 °F at any time subject only to the capacity of the system to maintain a given temperature setting.

2. Interior temperature distribution such that the difference in air temperature measured 5 ft

above the floor in the center of any two habitable rooms of the unit does not exceed 4 °F.

3. Air velocities within the occupied zones should not exceed 45 fpm with the system idle or operating. The occupied zone is defined as the region within a space between the 3-in and the 6-ft level above the floor and more than 2 ft from walls or fixed air-conditioning equipment.

4. Interior air temperature distribution such that the difference between any two air temperatures measured simultaneously within the occupied zones of all habitable rooms in the unit does not exceed 12 °F at any environmental load within design limits.

### 3. Description of the Test House

The test house was a factory-produced four-bedroom townhouse of modular design and of lightweight (wood) construction. A sketch of the test house in the environmental chamber is shown in figure 2. The particular townhouse studied in

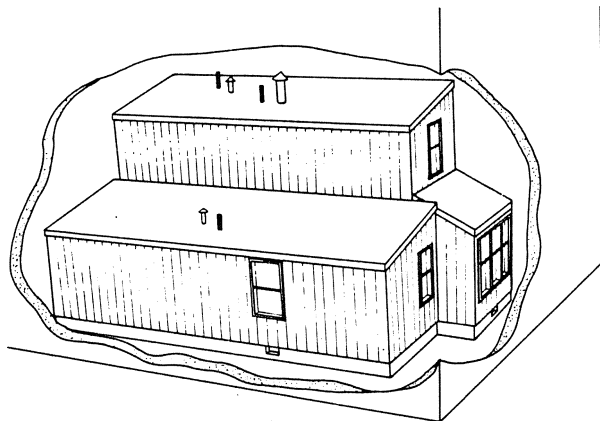

FIGURE 2. Test house in the Environmental Chamber.

this report was the left end dwelling of a row of townhouses and was constructed from three modular units. Two modules composed the first floor and contained the kitchen, dining area, utility room, living area, and two bedrooms separated by a full bath. (See first floor plan, fig. 3.) The second floor module contained two bedrooms and a second full bath with a stairway from the kitchen to the hallway connecting the bedrooms. (See second floor plan, fig. 4.) The floors of the living area, dining area, and the four bedrooms were carpeted. All other floor areas were finished with

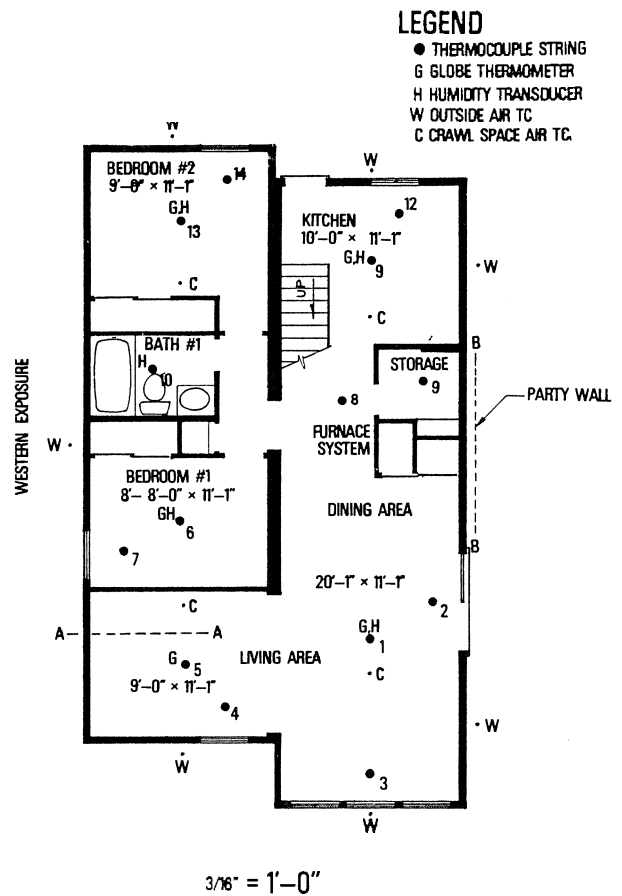

FIGURE 3. First floor plan of test house.

asphalt tile. As received from the factory, the townhouse was equipped with a refrigerator, an electric range, an 80-gal electric hot water heater, a gas-fired furnace, and electric air-conditioning equipment. Elevation plans of the townhouse are shown in figures 5 through 8. The total floor area of the townhouse was about 1200 ft<sup>2</sup>.

The townhouse was manufactured in Pennsylvania and transported about 200 miles on flat-bed trailers to NBS. It was assembled over a 2-ft-high crawl space in a high-bay environmental laboratory of approximately 70,000 ft<sup>3</sup> in volume. Figure 9 shows the three modules on flat-bed trailers upon arrival at NBS, and figures 10 and 11 show the assembly process. In this laboratory the temperature and relative humidity can be controlled over the ranges -50 to 150 °F and 15 to 85 percent, respectively. Temperatures and relative humidities can be changed as a function of time using cam-operated controllers.



above the floor in the center of any two habitable rooms of the unit does not exceed 4 °F.

3. Air velocities within the occupied zones should not exceed 45 fpm with the system idle or operating. The occupied zone is defined as the region within a space between the 3-in and the 6-ft level above the floor and more than 2 ft from walls or fixed air-conditioning equipment.

4. Interior air temperature distribution such that the difference between any two air temperatures measured simultaneously within the occupied zones of all habitable rooms in the unit does not exceed 12 °F at any environmental load within design limits.

### 3. Description of the Test House

The test house was a factory-produced four-bedroom townhouse of modular design and of lightweight (wood) construction. A sketch of the test house in the environmental chamber is shown in figure 2. The particular townhouse studied in

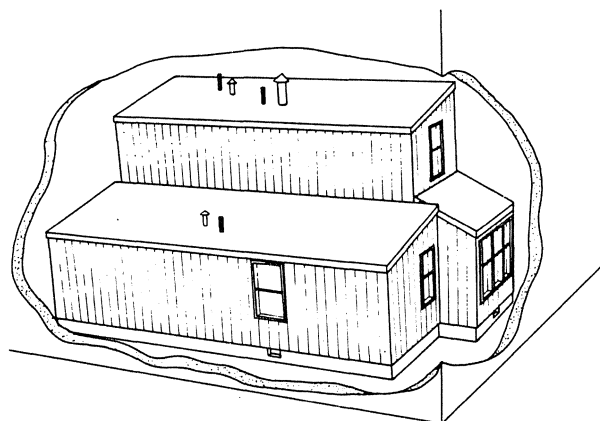
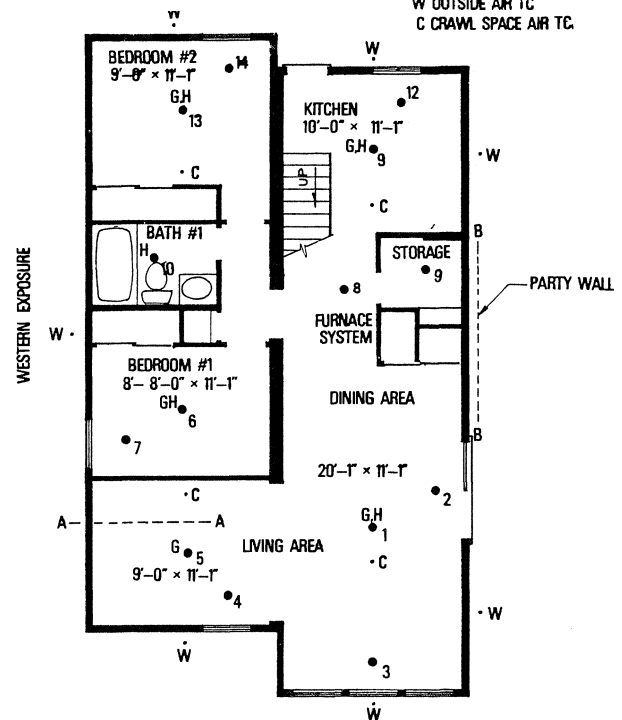

FIGURE 2. Test house in the Environmental Chamber.

this report was the left end dwelling of a row of townhouses and was constructed from three modular units. Two modules composed the first floor and contained the kitchen, dining area, utility room, living area, and two bedrooms separated by a full bath. (See first floor plan, fig. 3.) The second floor module contained two bedrooms and a second full bath with a stairway from the kitchen to the hallway connecting the bedrooms. (See second floor plan, fig. 4.) The floors of the living area, dining area, and the four bedrooms were carpeted. All other floor areas were finished with

### LEGEND

THERMOCOUPLE STRING  
G GLOBE THERMOMETER  
H HUMIDITY TRANSDUCER  
W OUTSIDE AIR TC  
C CRAWL SPACE AIR TC



3/16" = 1'-0"

FIGURE 3. First floor plan of test house.

asphalt tile. As received from the factory, the townhouse was equipped with a refrigerator, an electric range, an 80-gal electric hot water heater, a gas-fired furnace, and electric air-conditioning equipment. Elevation plans of the townhouse are shown in figures 5 through 8. The total floor area of the townhouse was about 1200 ft<sup>2</sup>.

The townhouse was manufactured in Pennsylvania and transported about 200 miles on flat-bed trailers to NBS. It was assembled over a 2-ft-high crawl space in a high-bay environmental laboratory of approximately 70,000 ft<sup>3</sup> in volume. Figure 9 shows the three modules on flat-bed trailers upon arrival at NBS, and figures 10 and 11 show the assembly process. In this laboratory the temperature and relative humidity can be controlled over the ranges -50 to 150 °F and 15 to 85 percent, respectively. Temperatures and relative humidities can be changed as a function of time using cam-operated controllers.

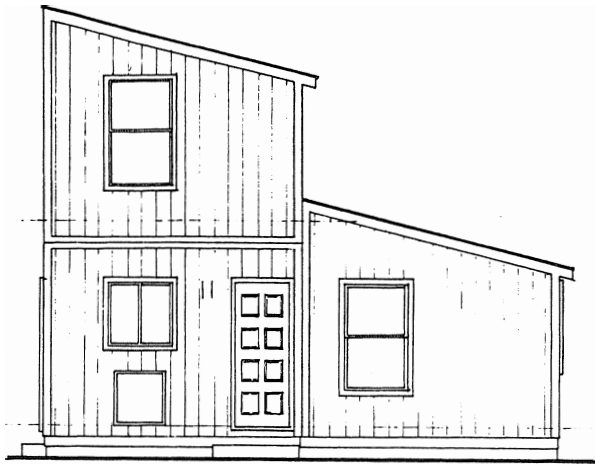

FIGURE 7. Rear elevation of test house.

tile and the remainder of the floor area was covered with 1/4-in nylon carpet. The construction materials of the roofs from the outside to the inside were: 1/8-in asphalt shingles, 1/16-in asphalt roofing felt, 1/2-in plywood sheathing, 5 1/2 in of glass fiber batt insulation with vapor barrier placed between nominal 2- by 6-in joists, and 1/2-in gypsum board nailed to the underside. The ceiling was painted.

The windows consisted of brown anodized aluminum frames and sash, with 1/8-in window panes, storm windows and screens. A typical window detail is shown in figure 14. There were five double-hung windows, 59-in high by 35-in wide, one for each of the four bedrooms and one in the living area. The living area had three

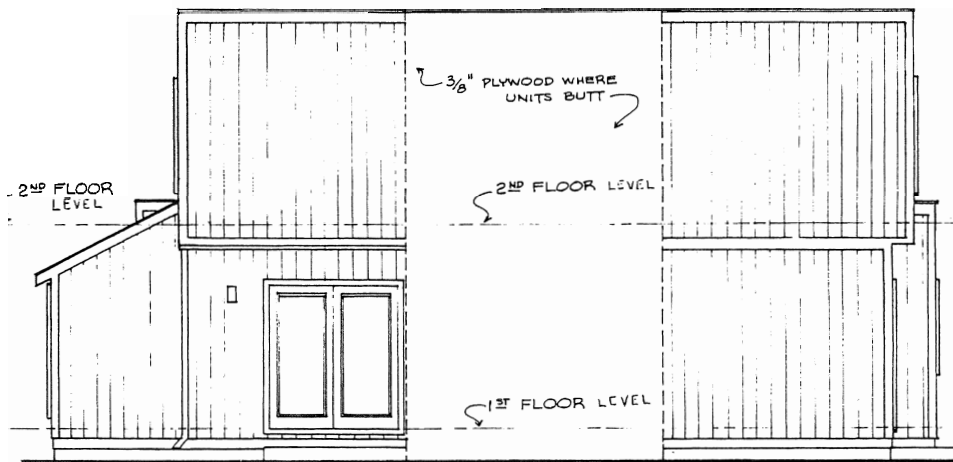

FIGURE 8. Side elevation of test house showing space for party wall for adjacent unit.



FIGURE 9. Arrival of three modular units at NBS.

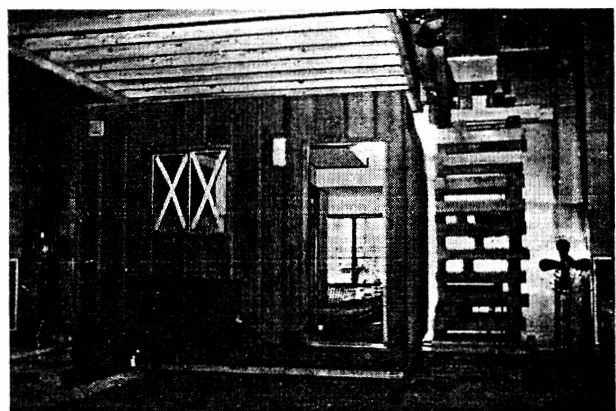

FIGURE 10. Module containing living room and kitchen being moved into laboratory beneath upstairs module.

The floor of the laboratory is undisturbed earth suitable for placing building foundations.

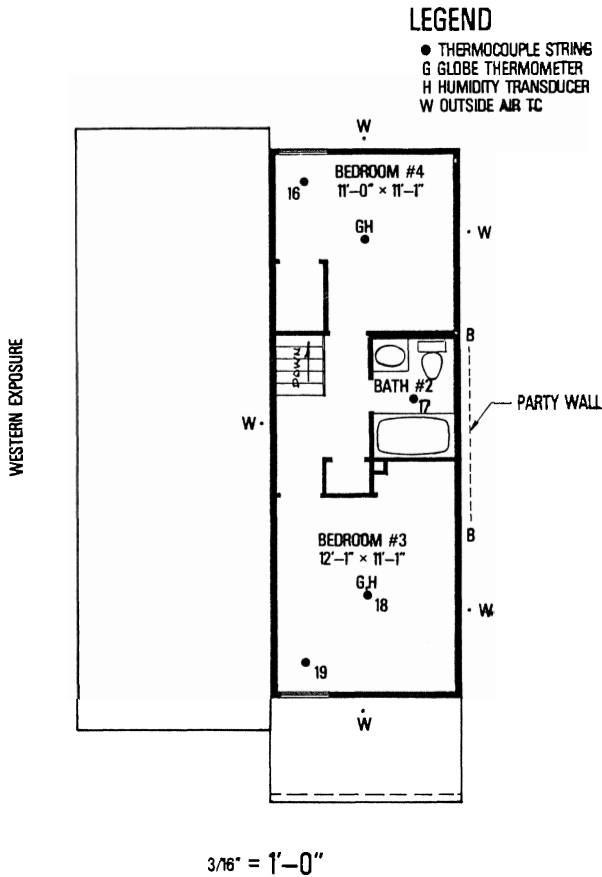

FIGURE 4. Second floor plan of test house.

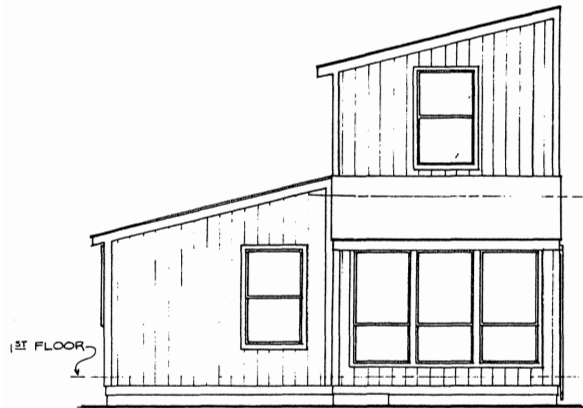

FIGURE 5. Front elevation of test house.

Typical construction details of the townhouse are shown in figures 12 and 13. The construction of the external walls from the outside to the inside was: 5/8-in-thick redwood veneer plywood siding running vertically, 3 1/2 in of glass fiber batt insulation with a vapor barrier placed between nominal 2- by 4-in wood studs, and 1/2-in-thick gypsum board nailed directly to the studding. The inside surfaces were painted. The floor above the crawl space consisted of 7 1/2 in of glass fiber insulation with a vapor barrier placed between nominal 2- by 8-in wood joists covered with 5/8-in plywood sheeting on top and nominal 1/4-in wood composition fiber board on the bottom. The floors in the kitchen, utility room, halls, and bathrooms were finished with 1/16-in-thick asphalt

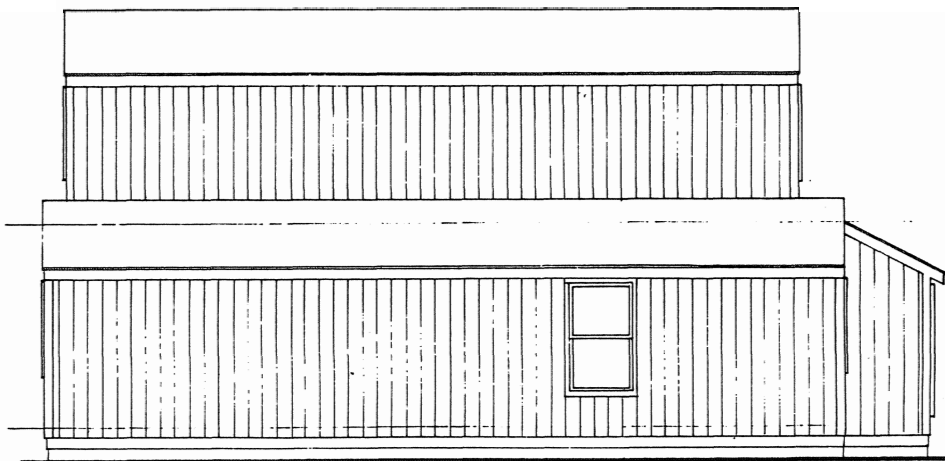

FIGURE 6. Side elevation of test house.



FIGURE 7. Rear elevation of test house.

tile and the remainder of the floor area was covered with 1/4-in nylon carpet. The construction materials of the roofs from the outside to the inside were: 1/8-in asphalt shingles, 1/16-in asphalt roofing felt, 1/2-in plywood sheathing, 5 1/2 in of glass fiber batt insulation with vapor barrier placed between nominal 2- by 6-in joists, and 1/2-in gypsum board nailed to the underside. The ceiling was painted.

The windows consisted of brown anodized aluminum frames and sash, with 1/8-in window panes, storm windows and screens. A typical window detail is shown in figure 14. There were five double-hung windows, 59-in high by 35-in wide, one for each of the four bedrooms and one in the living area. The living area had three

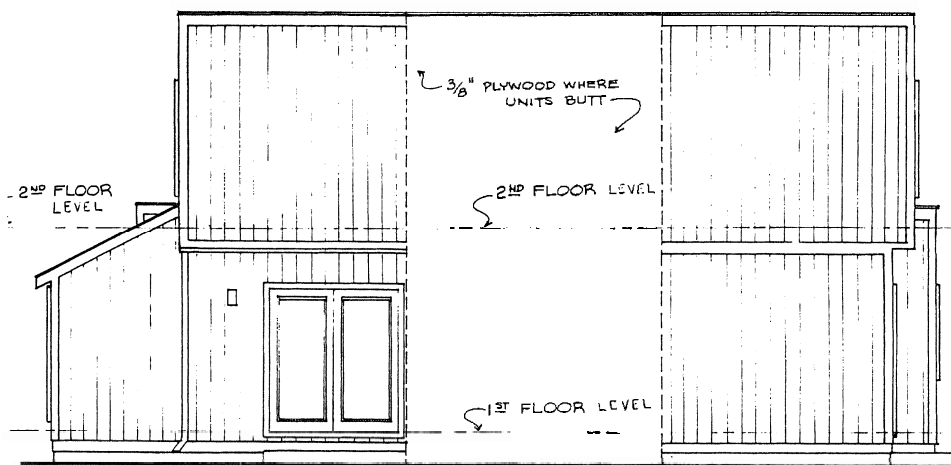

FIGURE 8. Side elevation of test house showing space for party wall for adjacent unit.



FIGURE 9. Arrival of three modular units at NBS.

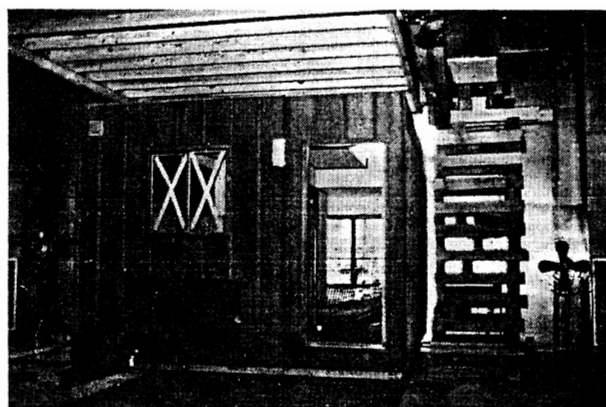

FIGURE 10. Module containing living room and kitchen being moved into laboratory beneath upstairs module.

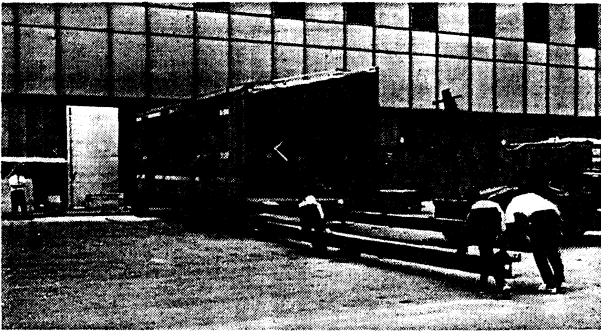

FIGURE 11. Third module placed into laboratory.

double-hung windows, 71-in high by 34-in wide placed in a row to form a picture window. The kitchen had a casement window, 34-in high by 35-in wide. The double front door contained two insulating glass units each 63-in high by 23-in wide. The rear door was solid. Each bathroom had a ventilating fan but no window.

The test house was assembled over a foundation and five piers constructed from two courses of mortared cinder-concrete blocks. The foundation and piers were constructed over a

reinforced concrete footing. A detailed illustration of the foundation, piers, and footings is given in figure 15. The earth crawl space floor was covered with a 10-mil polyethylene ground cover vapor barrier.

The equipment for heating, cooling, and distributing air was located in the left side of the living area closet and consisted of a gas-fired furnace, cooling coil, and forced air blower. A schematic of this equipment is shown in figure 16. A humidifier was added by NBS.

The thermostat was located on the hall wall between the living room and utility closet at a height of 5-ft 4-in above the floor. This thermostat also contained manual switches for heating, cooling, and fan-only operation.

The gas furnace was rated at 75,000 Btu h<sup>-1</sup> input and 60,000 Btu h<sup>-1</sup> output at the bonnet. The air conditioning equipment had a listed capacity of 24,000 Btu h<sup>-1</sup>. The condensing unit was located in an interior cabinet under the kitchen window with the outdoor coil projecting through the wall. A wetted-drum type domestic humidifier, shown in figure 17, was attached to the plenum of the air distribution system.

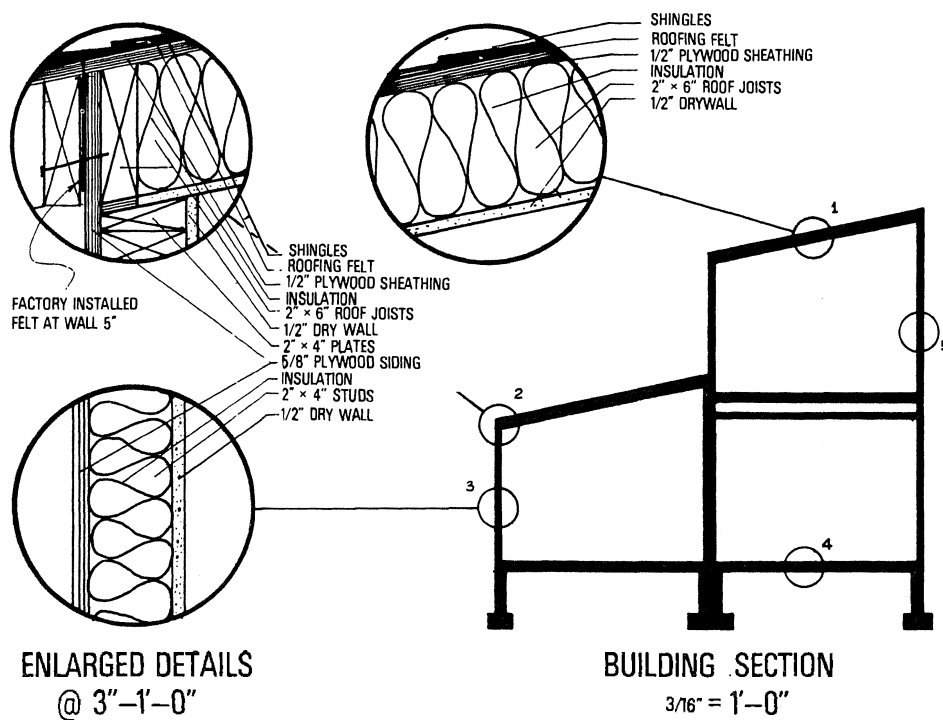

FIGURE 12. Typical construction details of walls and roof of test house.

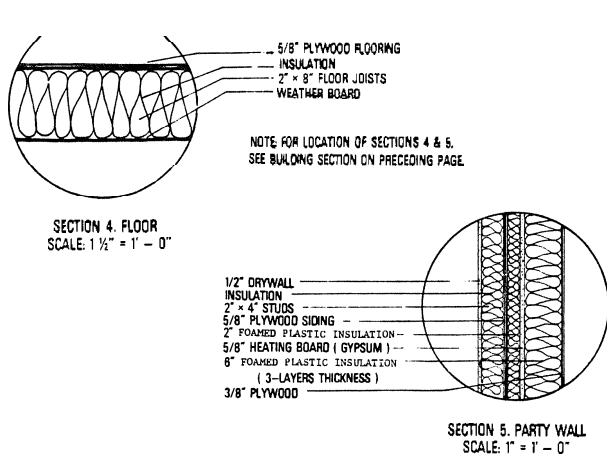

FIGURE 13. Typical construction details of floor and party wall of the test house.

After several tests with operation of the gas furnace, the system was modified for electric heating by the installation of three resistance heating elements in the plenum above the cooling coils. Each element was rated at 3460 W for 208-V operation. The voltage supplied to two of the elements was controlled by a variable transformer for varying the electric heat output.

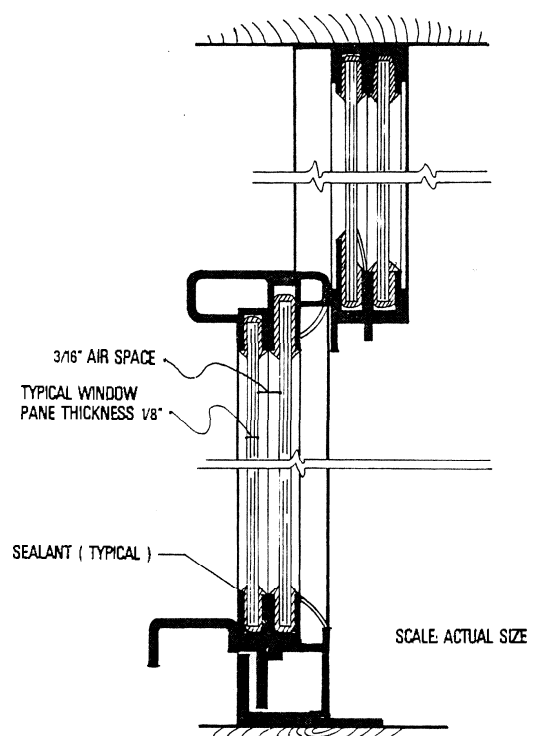

FIGURE 14. Typical window detail showing storm sash installed.

### FOUNDATION SECTIONS

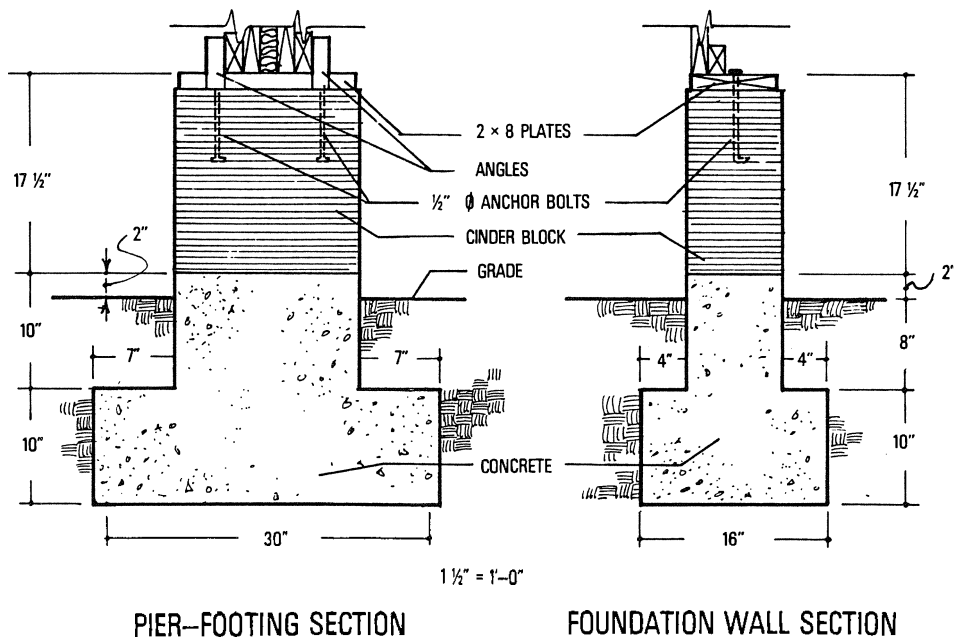

FIGURE 15. Detail sections of foundation pier and footings.

The air distribution system consisted of a common return (fig. 16), located in the hallway between the living room and the utility closet, with a circulating blower forcing air through the gas furnace into the distributing ducts and to the registers. There was one supply register located in each room located about 7 ft above the floor except for one low-wall register in the smaller upstairs bedroom.

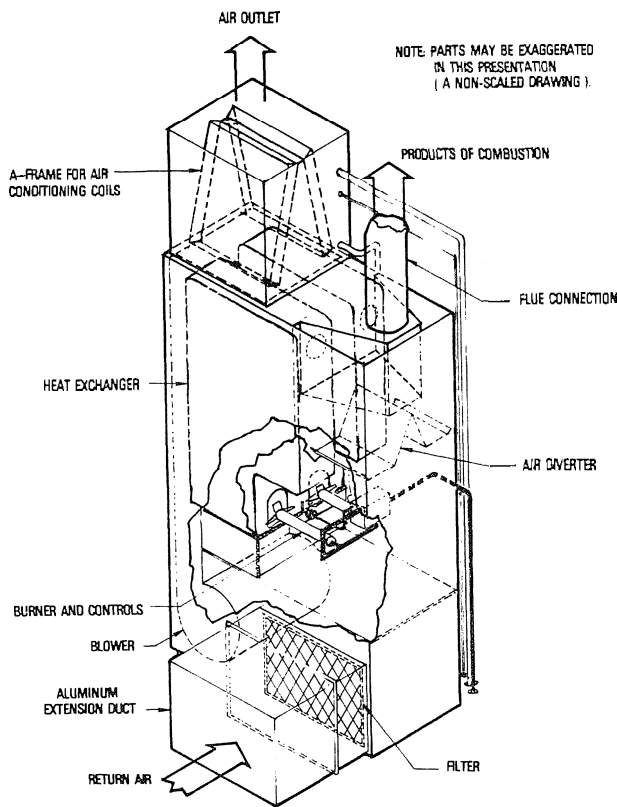

FIGURE 16. Schematic of gas-fired furnace, cooling coil, and forced air blower.

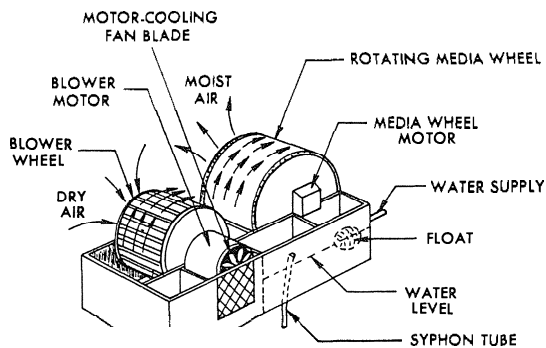

FIGURE 17. Wetted drum type humidifier.

Since interior furnishings will have an effect on the thermal behavior of a house, the test house was fully furnished with 3300 lb of furniture, draperies, and other household accessories including a stacked clothes washer and dryer, and a dishwasher. In addition, a garbage disposal unit was connected to the drain of the kitchen sink. Figures 18 through 20 show the furnishings of the house.



FIGURE 18. Photograph showing living room furniture.

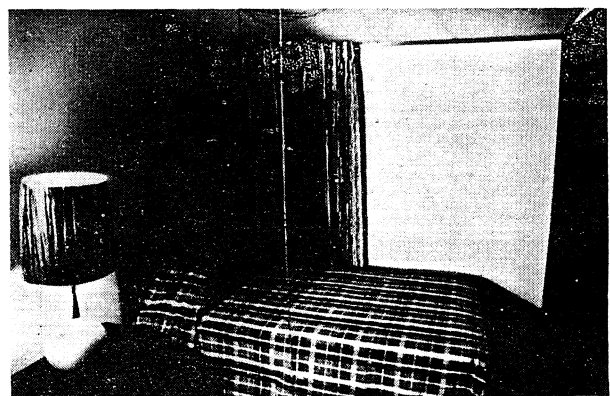

FIGURE 19. Photograph showing the furniture in bedroom number 1.

Gas, electric energy, and water were metered. Sewage and waste water from the townhouse were fed into a sump from which it was pumped selectively into either an aerobic sewage treatment facility which was located above grade directly in the chamber or to a sanitary drain. Treated water from the aerobic system was subsequently fed into the sanitary drain.

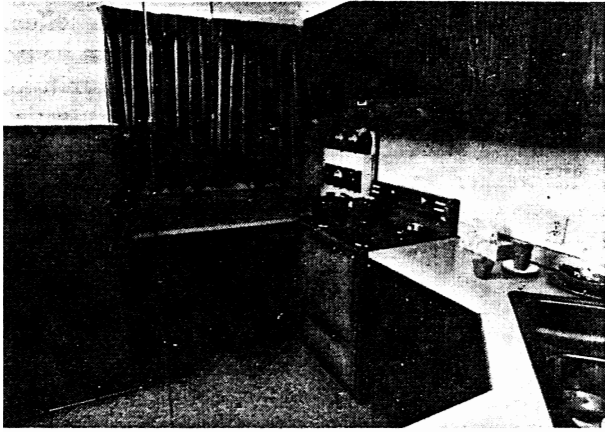

FIGURE 20. Photograph showing the kitchen and its appliances.

For expelling exhaust furnace flue gases a 12-in diam flexible hose was run from the flue gas stack located on the roof to the laboratory outdoor exhaust system. A photograph showing the flexible hose installation is shown in figure 21.

The clothes dryer in the utility room was vented to the outside by running a flexible hose from the dryer through the wall space above the kitchen cabinets to the exterior wall at the end of the kitchen.

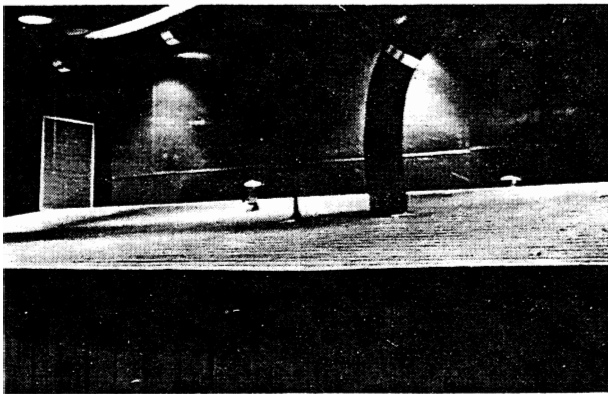

FIGURE 21. Photograph of the flexible hose installation for flue gas exhaust.

#### 4. Instrumentation and Transducers

Ambient air and surface temperatures were measured with 24-gage copper-constantan thermocouples. Thermocouple strings, suspended by 3/16-in diam polycarbonate rods, were placed

at the geometric center of each room and 2 ft from and horizontally centered in front of each of the windows. The locations of the thermocouple strings are numbered 1 through 19 and depicted with solid circles on the floor plans of figures 3 and 4. Six thermocouples were attached to a rod and located at 3, 30, 60, 72, and 84 in above the floor, and 3 in below the ceiling. Due to the low ceiling in the utility room, it was necessary to omit the thermocouple 3 in below the ceiling. Ambient air thermocouples also were placed 3 in in front of the seven air supply grills and 3 in in front of the thermostat for the furnace system. In addition, ambient air temperature thermocouples were placed 3 in in front of the wall, roof, and floor in the plane A-A of the living area (see floor plan of fig. 3). The floor and ceiling thermocouples were placed 30 in from the west wall, and the wall thermocouple was placed 60 in from the floor. The ambient air thermocouples of the thermocouple strings in the geometric center of the living area, kitchen, downstairs bathroom, and the bedrooms, along with those 3 in in front of the air supply grills, the furnace thermostat, the wall, roof, and floor were referenced to the ice point (32 °F) by connecting these thermocouples to a thermoelectric ice-point reference system. The other ambient air temperature thermocouples were referenced to a uniform-temperature reference junction maintained at approximately room temperature. The temperature of the reference junction or zone box was in turn referenced to 32 °F.

Globe thermometers were used to measure the mean radiant temperature (MRT) at the geometric center of the living room, den, kitchen, and four bedroom areas at the 30-in level above the floor. The locations of the globe thermometers are shown with the symbol G on the floor plans of figures 3 and 4. A globe thermometer consisted of a 6-in diam hollow copper sphere with a thermocouple supported in the center. The outside surface of the spheres were painted with matte-black paint, so as to absorb most of the long wave thermal radiation emitted from the inside surfaces of a room. A cross section of a globe thermometer is shown in figure 22.

Four thermocouples were placed in the crawl space 6 in below floor joists. The location of the crawl space thermocouples are depicted with the symbol C on the floor plan of figure 3. Outside



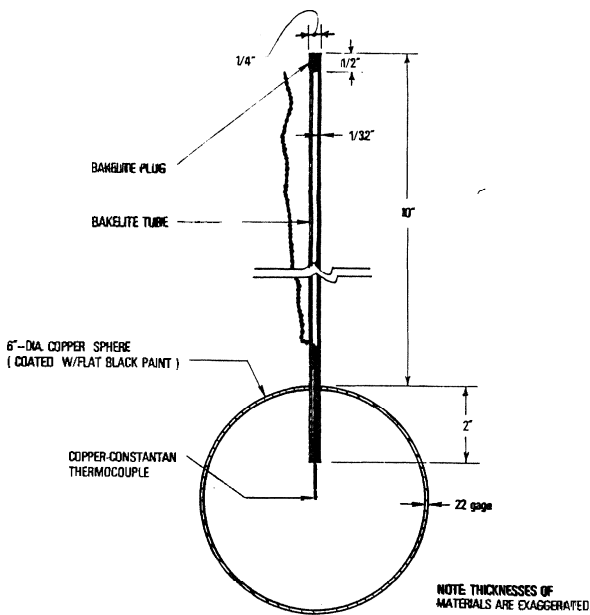

FIGURE 22. Cross section through globe thermometer.

ambient air temperature thermocouples were placed 1 ft from external surfaces of the townhouse. An attempt was made to locate these thermocouples in the geometric center of wall heat transfer surfaces. The outside air thermocouples for the walls are depicted with the symbol *W* on the floor plans of figures 3 and 4. Outside air temperature thermocouples were also placed in the geometric center and 1 ft above each of the three roof sections. Those in front of the walls on the first floor were placed 6 1/2 ft above the ground, while those for the second level walls were located 15 1/2 ft above the ground. The thermocouples in front of the bay window of the living room were located 9 1/2 ft above the ground.

Thermocouples were attached with aluminum adhesive tape at the center of the upper section of the double-hung windows. One of these thermocouples was placed on the inside surface of the inside pane and the other was located on the outside surface of the outside pane. For the bay window in the living room only the center double-hung window was instrumented with thermocouples. An identical thermocouple pair was placed on the lower section of the window in the den portion of the living area. For the casement window in the kitchen the thermocouple placement was identical, except that the thermocouple pair was placed on the right section of this

window. For the door in the living room an inside and outside thermocouple pair was attached to one of the glass panes. In addition, for the double-hung windows in the master bedroom and the center one of the living room, thermocouples were placed on glass surfaces within the air space formed by the double panes.

In a normal field application another townhouse would be attached to the test house studied in this report. The area of contact for the adjoining unit is shown with broken line B-B labeled party wall on the floor plans of figures 3 and 4. This surface should be maintained very nearly adiabatic, since the indoor air temperatures for the two townhouses are normally maintained approximately equal. The presence of the adjoining townhouse was simulated with the contact surface area (12-ft wide and 20-ft high) maintained at approximately 75 °F. The construction, shown in figure 13, consisted of 15 heating panels of 5/8-in thickness. The layer of heating panels were placed over a 2-in layer of polystyrene board-type insulation covered with a 6-in layer of polystyrene insulation and a 3/8-in plywood cover. The surface temperature of the heating panels facing the townhouse was maintained at 75 °F within a 4 °F band by controlling the electrical energy supplied to the heating panels. The sensing element of a thermostat was two thermocouples attached to the inside surface of the heating panels. These thermocouples were horizontally centered and placed 8 and 13 ft from the bottom edge of the simulated party wall. The temperature of the simulated party wall was measured with eight thermocouples. Four of these thermocouples were attached to the redwood siding (two were placed 8 ft from the bottom edge and 3 ft from either side edge of the simulated party wall. The other two were placed directly above the former at the 13-ft level). The other four thermocouples were placed in the same locations as the previous four thermocouples but on the other side of insulation in contact with the heating panel.

Relative humidity transducers were placed in the geometric center of the living room, kitchen, bathrooms, and bedrooms at the 60-in level above the floor. These humidity transducers produced a millivolt output signal proportional to the relative humidity. The temperature of the return air for the heating and cooling equipment

was measured by a network of four thermocouples which were connected electrically in parallel. In addition, a network of eight thermocouples was placed in the air outlet above the cooling coils to measure the temperature of the air distributed to the rooms. The air delivery rate of the furnace blower was determined with a vane anemometer. An aluminum duct was placed in front of the return air supply before it entered the grill, to make air velocity measurements. A grid network of four thermocouples was mounted in the flue that protruded from the roof of the house. A sample of the flue gas was continuously pumped from a tap in the flue pipe at the second floor level to an infrared gas analyzer which continuously registered the percent carbon-dioxide content.

An adequate indoor humidity level was maintained in the house during winter testing periods by the operation of a humidifier connected to the plenum of the furnace. Warm air from the plenum was drawn into the humidifier by its self-contained blower. This heated air was forced through a sponge-like media pad which rotated slowly in a bath of water to constantly add moisture to the dry air. Moisture-laden air was then returned into the plenum and was distributed to the test house. Water was supplied to the humidifier by a tank located in the second-floor linen closet. The amount of water used by the humidifier during a given time period was determined by measuring the difference in water level in the supply tank at the beginning and end of a time period. The water level in this tank was measured with a static pressure transducer that generated a millivolt signal proportional to the water level in the tank.

Six heat flow meters were placed on inside surfaces to measure heat flow through external building components. Each heat flow meter was masked with a 2-in-wide circular commercial gum rubber border having approximately the same thickness as the heat flow meter. A 6-in diam and 1/8-in thick commercial gum rubber cover was secured to the top of the masked heat flow meter. The purpose of the mask and cover was to eliminate fluctuations in the millivolt output due to local variations in the air flow in the vicinity of the heat flow meter. Two of these meters were placed in plane A-A (fig. 3) on the wall of the den 60 in above the floor. One of these was located over a wooden stud and one was placed over the

space between wooden studs. Two other pairs of heat flow meters were placed on the roof and floor at corresponding locations in the plane A-A and 30 in from the west wall. The heat flow meters consisted of a 2.0-in diam, 0.13-in thick, circular disk made of tan polyvinylchloride filler material, each having an embedded thermopile. The millivolt signal generated by the thermopile is proportional to the heat flow through the circular disk. The heat flow meters were calibrated in an 8-in guarded hot plate apparatus conforming with the requirements of Standard Method of Test ASTM C177.

Six thermocouples were glued to the inside surfaces in the plane A-A just above each of the heat flow meters. In addition, six thermocouples were attached to the outside surface of the building at corresponding locations.

The volume of natural gas consumed by the furnace in the townhouse was measured with a calibrated domestic gas meter that was specially modified, so that the passage of 1 ft<sup>3</sup> of gas caused an electric pulse to be generated. This was accomplished by placing an excitation voltage across a micro-switch that rode on a cam shaft of the metering circuit. The temperature and pressure of the gas at the inlet to the gas meter were also monitored, so that the volumetric consumption of gas could be corrected for changes in density. The gas temperature was measured with a thermocouple placed inside a tube that protruded into the gas stream. The pressure of the gas was metered with a static pressure gage.

The gross electric energy supplied to the house was measured using a calibrated 3-wire watt-hour meter equipped with an impulse generator. The impulse generator was a photoelectric device which generated a pulse for each revolution of a disk inside the meter.

The transducer signals were fed into a data acquisition system which in turn recorded these signals on punched cards at selected time intervals. The gas and electric pulses were totalized and also fed into this data acquisition system.

The individual electric energy consumption of the furnace blower, refrigerator, electric range, washer and dryer (and humidifier), air conditioner, and hot water heater were monitored with single-phase Wh meters mounted on the east wall of the kitchen. The difference between the gross energy

and the sum of the energies supplied to the above circuits was equal to the energy for the lights, kitchen and bathroom blowers, radio, and disposal.

Air velocities in excess of 80 fpm were measured with conventional vane and hot wire anemometers. Both of these instruments were calibrated in a wind tunnel. For velocities below 60 fpm, a low velocity anemometer utilizing a vibrating hot-wire probe was used. The low velocity anemometer used in this study was calibrated by its manufacturer.

## 5. Experimental Methods and Conditions

Prior to and during tests performed, certain guidelines and conditions were established for laboratory testing. For example, in the laboratory it was not planned to obtain time dependent data on the effects of outside conditions of wind, rain, snow, and incident solar radiation upon the house. These variables were handled in the weather portion of the predictive NBSLD computer program. Also, it is planned to expose this house to natural weather conditions at the NBS site at the conclusion of laboratory tests. In the following sections the experimental methods and conditions used are set forth for a comparison of the laboratory testing results and computer predictions.

### 5.1. Simulated Outdoor Weather Cycles

The outdoor conditions used for testing of the house were taken from Weather Bureau data for two locations—Macon, Ga. and Kalamazoo, Mich. where similar models of the test house have been installed. Winter and summer data were chosen to include recommended outdoor design conditions as given in the ASHRAE Handbook of Fundamentals, and include sol-air temperatures. The sol-air temperatures were computed using the algorithms of [5], and were averaged by weighting the areas of the exposed surfaces.

In order to obtain an area-averaged sol-air temperature, it was assumed that the two large sloping roof areas faced west. The areas for the various orientations are:

North facing wall	339.0 ft <sup>2</sup>
East facing wall	512.0 ft <sup>2</sup>
South facing wall	282.0 ft <sup>2</sup>
West facing wall	485.5 ft <sup>2</sup>
West facing roof	887.5 ft <sup>2</sup>
South facing roof	78.0 ft <sup>2</sup>

The values of the ratio of the absorptance of surfaces,  $\alpha$ , to the coefficient of heat transfer,  $h_0$ , were 0.2 and 0.3 for the wall and roof areas, respectively. These values were derived from comparative temperature measurements made on materials of the house and materials of known absorptance that were exposed to solar radiation on the grounds of NBS.

In addition to the winter and summer days where only heating or cooling is needed, it was decided to pick a day in either the spring or fall when outside conditions might indicate that both heating and cooling may be needed in a diurnal cycle. For this, a search of Weather Bureau data was made to find days where the daily change in dry-bulb temperature was more than 35 °F and the maximum temperature was greater than 75 °F. These conditions were satisfied for many days in the fall for Macon, Ga., but rarely occurred for Kalamazoo, Mich.

#### 5.1.1. Macon, Georgia

From the ASHRAE Handbook of Fundamentals, the winter design (99%) temperature is 23 °F and the summer design (1%) dry-and wet-bulb temperatures for Macon, Ga. are 98 °F and 80 °F, respectively.

From Weather Bureau data covering the 10-yr time period from January 1, 1949 to December 31, 1958, there were 25 winter days when the temperature dropped below the design temperature of 23 °F for two or more hours. The lowest temperature recorded during this time period was 11 °F on February 17, 1958.

December 18, 1953 was picked as a design day where the average dry-bulb temperature from midnight to 8 a.m. was slightly less than 23 °F. The pertinent weather data for this day are shown in figure 23 and the sol-air temperatures for the various orientations of walls and roofs are plotted on figure 24. The sol-air temperatures were computed from the algorithms given in the ASHRAE Procedure for Determining Heating and

Cooling Loads for Computerized Energy Calculations [5]. Figure 24 shows that the nighttime air temperature for the roof areas is below the design temperature. This effect is due to nighttime sky radiation to cloudless skies.

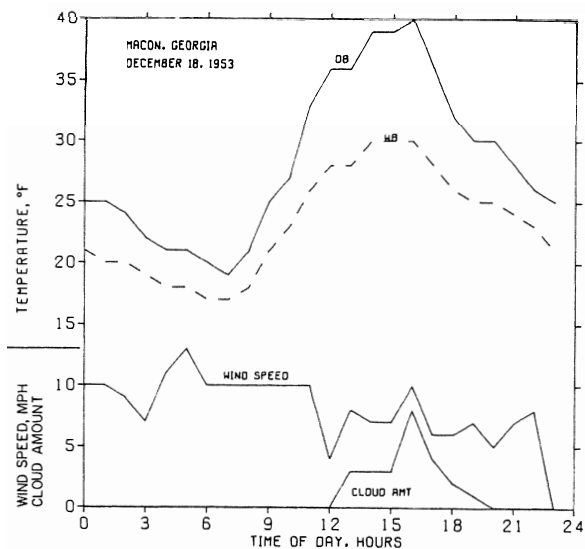

FIGURE 23. Weather data for Macon, Georgia, December 18, 1953.

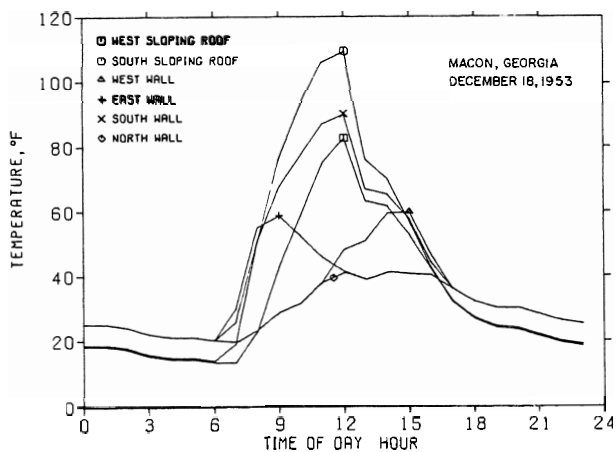

FIGURE 24. Computed sol-air temperature for various orientations—Macon, Georgia, December 18, 1953.

Assuming that the two large sloping roof areas of the test house face west, an area average of the sol-air temperatures of figure 24 gives the sol-air temperature with time as shown in figure 25. This is the outdoor air temperature cycle used in heating tests for the house.

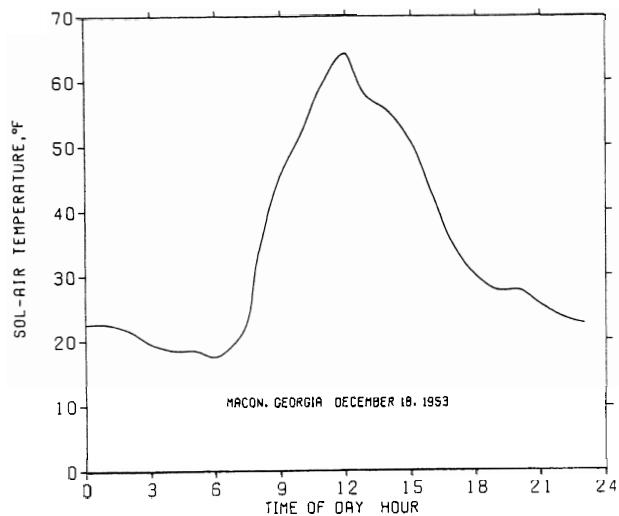

FIGURE 25. Area averaged sol-air temperature for Macon, Georgia, December 18, 1953.

From the Weather Bureau data for this same 10-yr period, there were 40 summer days when the dry-bulb temperature exceeded the design temperature of 98 °F for two or more consecutive hours. The highest temperature recorded for this time period was 106 °F on June 28, 1954. June 30, 1952 was picked as a design day where the coincident dry- and wet-bulb temperatures were equal to the design values of 98 °F and 80 °F, respectively, for the hours of 2 and 3 p.m. The pertinent weather data for this day are shown in figure 26 and the sol-air temperatures for the

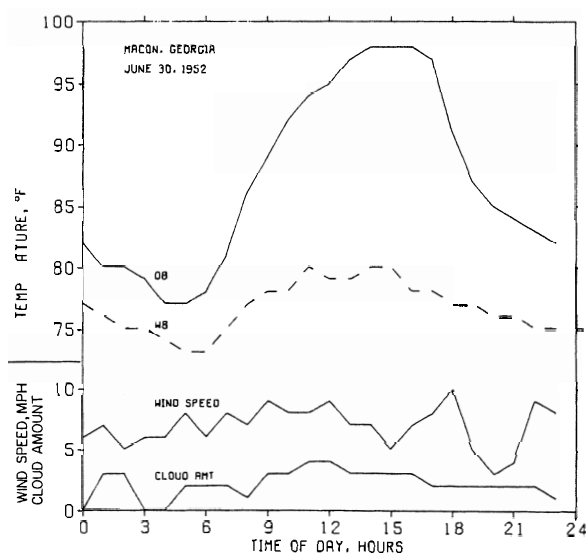

FIGURE 26. Weather data for Macon, Georgia, June 30, 1952.

various orientations of walls and roofs are plotted on figure 27. The area-averaged sol-air temperatures are shown in figure 28. This is the outdoor air temperature cycle used in cooling tests for the house.

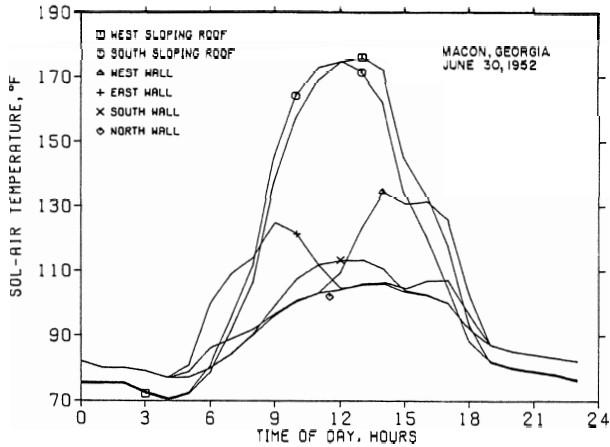

FIGURE 27. Computed sol-air temperature for various orientations, Macon, Georgia, June 30, 1952.

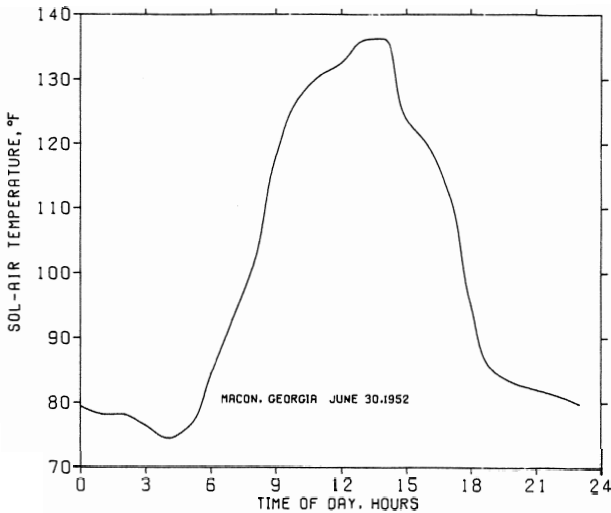

FIGURE 28. Area averaged sol-air temperature, Macon, Georgia, June 30, 1952.

From the Weather Bureau data for this same 10-yr period, there were 96 days during September, October, and November when the daily change in dry-bulb temperature exceeded 35 °F and the maximum temperature was greater than 75 °F. The largest daily change in temperature was 45 °F. A plot of dry- and wet-bulb temperature and wind speed for October 25, 1952 is shown in figure 29. This was a cloudless day for

which the maximum and minimum temperature was 81 and 40 °F, respectively. The sol-air temperature for surface orientations is shown in figure 30 and the area averaged sol-air temperature is given in figure 31. This is the outdoor air temperature cycle used in the fall season tests for the house.

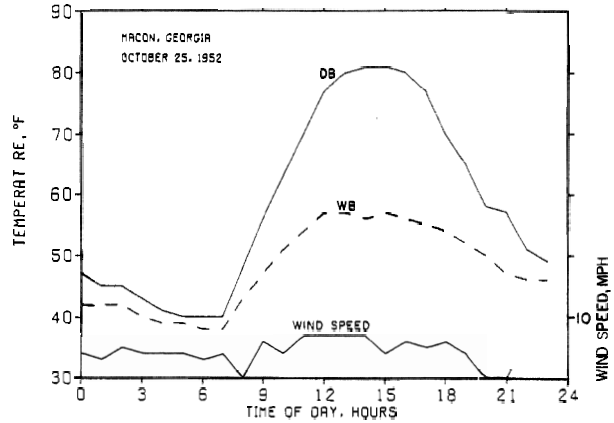

FIGURE 29. Weather data for Macon, Georgia, October 25, 1952.

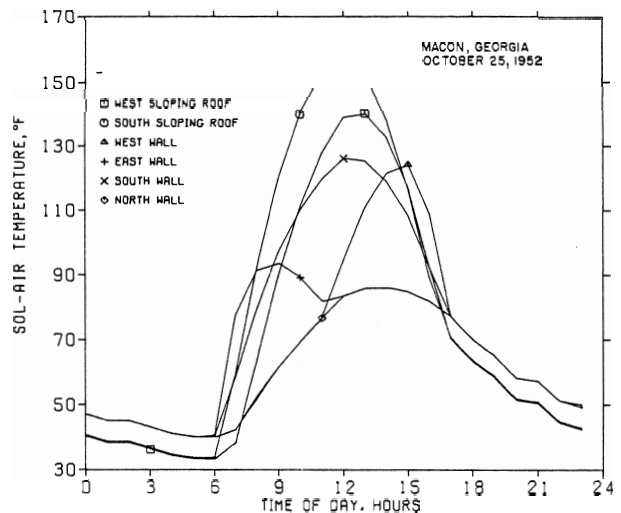

FIGURE 30. Computed sol-air temperature for various orientations, Macon, Georgia, October 25, 1952.

### 5.1.2. Kalamazoo, Michigan (Battle Creek)

From the ASHRAE Handbook of Fundamentals, the winter design (99%) temperature is 1 °F and the summer design (1%) dry- and wet-bulb temperatures for Kalamazoo, Mich. are 92 and 76 °F, respectively.

From Weather Bureau data covering the 6-yr period from January 1, 1949 to December 1, 1954, there were 12 winter days when the temperature dropped below the design temperature of 1 °F for 2 h or more. The lowest temperature recorded during this time period was -12 °F on February 2, 1951. December 22, 1951 was picked as a design day where the average dry-bulb temperature from midnight to 8 a.m. was approximately 1 °F. Using the same procedure as given for Macon, Ga., the variation of the sol-air temperature with time is shown in figure 32. This is the outdoor air temperature cycle used in heating tests for the house.

From the Weather Bureau data for this same 6-yr period there were 23 summer days when the dry-bulb temperature exceeded the design temperature for two or more consecutive hours. The highest temperature recorded during this time period was 99 °F on June 20, 1953 and September 2, 1953. July 25, 1949 was picked as a design day and the area averaged sol-air temperatures are shown in figure 33. This is the outside air temperature cycle used in the cooling tests for the house.

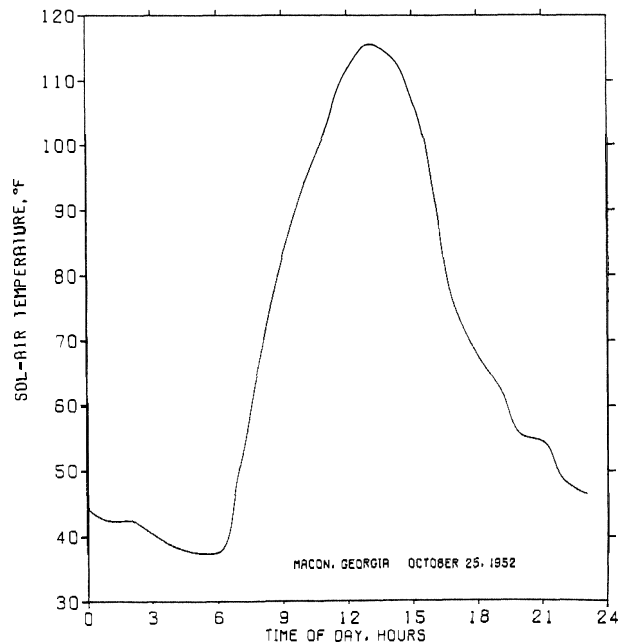

FIGURE 31. Area averaged sol-air temperature, Macon, Georgia, October 25, 1952.

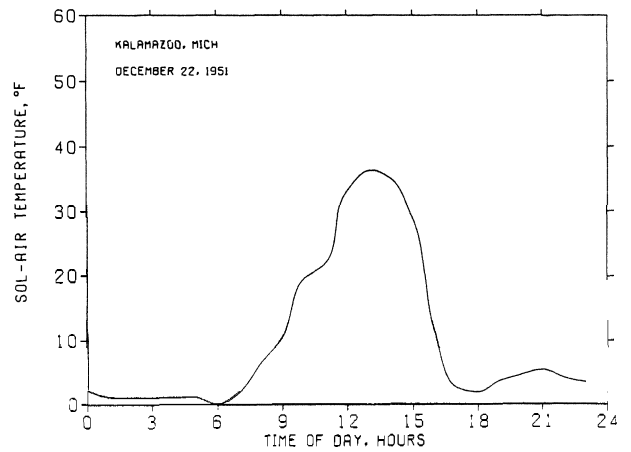

FIGURE 32. Area averaged sol-air temperature for Kalamazoo, Michigan, December 22, 1951.

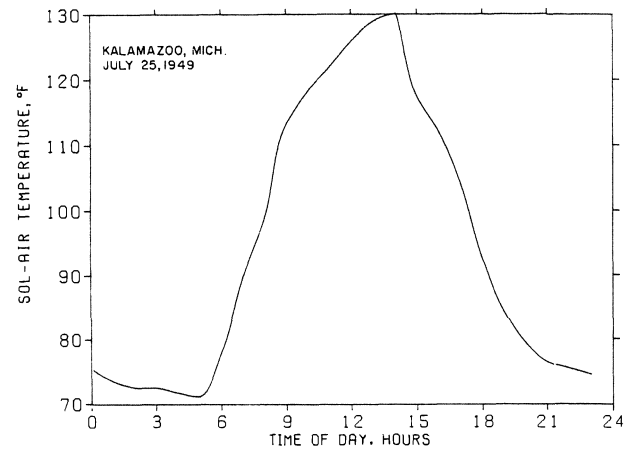

FIGURE 33. Area averaged sol-air temperature, Kalamazoo, Michigan, July 25, 1949.

## 5.2. Simulated Occupancy

To achieve realistic conditions for the operation of the townhouse while under test, it was necessary to simulate the occupancy and activities of a family living in the house. The diurnal activities of a family as a series of events in conjunction with an outside weather cycle may have a significant effect on the heating and cooling load of a building. The release of heat to the house from metabolic processes and by the use of lights and appliances and the increase in air infiltration rates by door and window openings are the dynamic considerations for thermal performance.

Because there are no published representative schedules of activities for occupants of residences and the characteristics of family activities vary widely from geographic and other considerations, the simulated occupancy and activity schedules used in conjunction with tests on the four-bedroom townhouse are based on assumptions set forth by the authors. The occupants are assumed to be a family of six, composed of a father, mother, two girls (ages 12 and 16), and two boys (ages 6 and 8). Activities for each member of the family are detailed in the

following paragraphs, so as to be consistent with "assumed" typical family living patterns for both winter and summer conditions.

Detailed activities of family members for winter conditions are shown in table 1. Specifically, this schedule is based on the children attending school, the father going to work and the mother performing household tasks. Activities for a summer condition are shown in table 2. The children are assumed to be at home during a greater portion of the summer daytime hours rather than attending school.

TABLE 1. Winter daily living pattern for occupants of test house

<i>Father</i>		2245 - 2300	Uses upstairs bathroom
0000 - 0700	Sleeps	2300 - 2400	Sleeps
0700 - 0715	Uses upstairs bathroom	<i>Girl - 16</i>	
0715 - 0730	Dresses in master bedroom	0000 - 0700	Sleeps
0730 - 0800	Eats breakfast	0700 - 0715	Uses downstairs bathroom
0800 - 1800	At work	0715 - 0730	Dresses in her bedroom
1800 - 1830	Enters house and relaxes in living room	0730 - 0800	Eats breakfast
1830 - 1900	Eats dinner	0800 - 0830	Prepares for school in her bedroom
1900 - 2230	Miscellaneous activities in living room	0830 - 1530	At school
2230 - 2245	Uses upstairs bathroom	1530 - 1730	Miscellaneous activities in living room
2245 - 2400	Sleeps	1730 - 1830	Helps prepare dinner
<i>Mother</i>		1830 - 1900	Eats dinner
0000 - 0630	Sleeps	1900 - 1930	Dinner clean up in kitchen
0630 - 0645	Uses upstairs bathroom	1930 - 2030	Studies in bedroom
0645 - 0700	Dresses in master bedroom	2030 - 2200	Miscellaneous activities in living room
0700 - 0730	Prepares breakfast	2200 - 2230	Uses downstairs bathroom
0730 - 0800	Eats breakfast	2230 - 2400	Sleeps
0800 - 0815	Cleans off dining room table and prepares breakfast for boys	<i>Girl - 12</i>	
0815 - 0830	Prepares children for school	0000 - 0715	Sleeps
0830 - 0900	Cleans up after breakfast	0715 - 0730	Uses downstairs bathroom
0900 - 0930	Washes and dries clothes	0730 - 0800	Eats breakfast
0930 - 1000	Vacuums downstairs	0800 - 0830	Dresses in bedroom and gets ready for school
1000 - 1015	Cleans downstairs bathroom	0830 - 1530	At school
1015 - 1100	Washes and waxes kitchen floor	1530 - 1600	Miscellaneous activity in living room
1100 - 1200	Relaxes in living room	1600 - 1830	Plays outside
1200 - 1215	Eats quick lunch	1830 - 1900	Eats dinner
1215 - 1230	Cleans up lunch	1900 - 1930	Miscellaneous activities in family room
1230 - 1500	Goes shopping	1930 - 2030	Studies in bedroom
1500 - 1730	Tending to needs of children	2030 - 2130	Miscellaneous activities in living room
1730 - 1830	Prepares dinner	2130 - 2200	Uses downstairs bathroom
1830 - 1900	Eats dinner	2200 - 2400	Sleeps
1900 - 1930	Cleans up dinner		
1930 - 2245	Miscellaneous activities in living room		

TABLE 1. *Winter daily living pattern for occupants of test house—Continued*

<i>Boy - 6</i>		<i>Boy - 8</i>	
0000 - 0745	Sleeps	0000 - 0645	Sleeps
0745 - 0800	Uses upstairs bathroom	0645 - 0700	Uses upstairs bathroom
0800 - 0825	Dresses in bedroom	0700 - 0730	Dresses and prepares for school in bedroom
0815 - 0830	Eats breakfast	0730 - 0800	Miscellaneous activities in living room
0830 - 1530	At school	0800 - 0830	Eats breakfast
1530 - 1700	Comes home from school and plays outside	0830 - 1530	At school
1700 - 1830	Miscellaneous activities in living room	1530 - 1700	Comes home from school and plays outside
1830 - 1900	Eats dinner	1700 - 1830	Miscellaneous activities in living room
1900 - 1930	Miscellaneous activities in living room	1830 - 1900	Eats dinner
1930 - 2030	Studies in bedroom	1900 - 1930	Miscellaneous activities in living room
2030 - 2100	Uses downstairs bathroom	1930 - 2030	Studies in bedroom
2100 - 2400	Sleeps	2030 - 2100	Uses upstairs bathroom
		2100 - 2400	Sleeps

TABLE 2. *Summer daily living pattern for occupants of test house*

<i>Father</i>			
0000 - 0700	Sleeps	1200 - 1230	Eats lunch
0700 - 0715	Uses upstairs bathroom	1230 - 1300	Cleans up lunch
0715 - 0730	Dresses in master bedroom	1300 - 1600	Takes children to community swimming pool
0730 - 0800	Eats breakfast	1600 - 1700	House cleaning in downstairs bedrooms
0800 - 1800	At work	1700 - 1730	Relaxes in living room and tends to the needs of the children
1800 - 1830	Enters house and relaxes in living room	1730 - 1830	Prepares dinner
1830 - 1900	Eats dinner	1830 - 1900	Eats dinner
1900 - 2100	Sitting outside	1900 - 1930	Cleans up dinner
2100 - 2230	Miscellaneous activities in living room	1930 - 2100	Sits outside with husband
2230 - 2245	Uses upstairs bathroom	2100 - 2245	Miscellaneous activities in living room
2245 - 2400	Sleeps	2245 - 2300	Uses upstairs bathroom
		2300 - 2400	Sleeps
<i>Mother</i>		<i>Girl - 16</i>	
0000 - 0630	Sleeps	0000 - 0700	Sleeps
0630 - 0645	Uses upstairs bathroom	0700 - 0715	Uses downstairs bathroom
0645 - 0700	Dresses in master bedroom	0715 - 0730	Dresses in her bedroom
0700 - 0730	Prepares breakfast	0730 - 0800	Eats breakfast
0730 - 0800	Eats breakfast	0800 - 0830	Grooms herself in bedroom
0800 - 0815	Cleans up in kitchen and prepares breakfast for boys	0830 - 1200	Visits a girls friend
0815 - 0830	Tends to the needs of the children	1200 - 1230	Eats lunch
0830 - 0900	Cleans up breakfast	1230 - 1300	Helps mother clean up
0900 - 0930	Washes and dries clothes	1300 - 1600	Goes swimming
0930 - 1000	Vacuums upstairs	1600 - 1830	Goes bicycle riding with friends
1000 - 1015	Cleans upstairs bathroom	1830 - 1900	Eats dinner
1015 - 1100	House cleaning in living room	1900 - 1930	Helps mother with after dinner clean up
1100 - 1130	Relaxes in living room and tends to the needs of the children	1930 - 2200	Goes out on a date
1130 - 1200	Prepares lunch	2200 - 2230	Uses downstairs bathroom
		2230 - 2400	Sleeps



TABLE 2. Summer daily living pattern for occupants of test house—Continued

<i>Girl - 12</i>		1230 - 1300	Prepares for swimming, in bedroom
0000 - 0715	Sleeps	1300 - 1600	Goes to community swimming pool
0715 - 0730	Uses downstairs bathroom	1600 - 1830	Plays outside
0730 - 0800	Eats breakfast	1830 - 1900	Eats dinner
0800 - 0815	Cleans up dining room	1900 - 2030	Plays outside
0815 - 0830	Grooms herself in bedroom	2030 - 2100	Uses downstairs bathroom
0830 - 1200	Visits a girl friend	2100 - 2400	Sleeps
1200 - 1230	Eats lunch		
1230 - 1300	Cleans up lunch in kitchen	<i>Boy - 8</i>	
1300 - 1600	Swimming at community pool	0000 - 0645	Sleeps
1600 - 1830	Plays outside	0645 - 0700	Uses upstairs bathroom
1830 - 1900	Eats dinner	0700 - 0730	Dresses in bedroom
1900 - 1930	Cleans up dinner	0730 - 0800	Miscellaneous activities in living room
1930 - 2100	Plays outside	0800 - 0830	Eats breakfast
2100 - 2130	Miscellaneous activities in living room	0830 - 1200	Plays outside
2130 - 2200	Uses downstairs bathroom	1200 - 1230	Eats lunch
2200 - 2400	Sleeps	1230 - 1300	Prepares for swimming, in bedroom
		1300 - 1600	Swims in community pool
<i>Boy - 6</i>		1600 - 1830	Plays outside
0000 - 0745	Sleeps	1830 - 1900	Eats dinner
0745 - 0800	Uses upstairs bathroom	1900 - 2030	Plays outside
0800 - 0815	Dresses in bedroom	2030 - 2100	Uses downstairs bathroom
0815 - 0830	Eats breakfast	2100 - 2400	Sleeps
0830 - 1200	Plays outside		
1200 - 1230	Eats lunch		

The metabolic heat production rates assumed for members of the family are given in table 3, where the rates are dependent upon age and type of activity: sleeping, sitting, and moderate work. The rates for the adults are taken from the available literature, and the rates for other family members are proportional to assumed body surface areas. Where the metabolic rates include both sensible and latent heat, the simulation was made for the total as sensible heat by placing arrays of electric lights at appropriate locations throughout the house. Each array was adjusted so that heat given off by the bulbs would simulate the net metabolic heat produced for occupancy of the room at the appropriate time of day.

TABLE 3. Metabolic heat production rates ( $Btu\ h^{-1}$ )

Activity Level	Family Member			
	Father	Mother	Girls	Boys
Sleeping	250.	250.	187.5	125.
Sitting	400.	400.	300.	200.
Moderate work	660.	660.	495.	330.

The heat released by appliances and equipment is the most significant occupancy-related heat producing activity of the operating schedule. Energy release rates for the various appliances are summarized in table 4.

The energy release rates were experimentally determined by operating each appliance and measuring energy consumption with watt-hour

TABLE 4. Energy release rates for operating appliances,  $Btu\ h^{-1}$

Hot water heater	10410.
Refrigeration	575.
Clothes washer (average during cycle)	618.
Dish washer	2100.
Range, oven	2790.
Range, burner	1025.
Television (simulated by lights)	1708.
Clothes dryer	5464.
Instrumentation (continuous)	437.
Vacuum sweeper	1810.

meters. For the clothes dryer it was determined that about 15 percent of the energy consumed was released to the house and the remainder was vented to the outside.

Without hot water usage, the average heat loss from the hot water heater was about 590 Btu h<sup>-1</sup> or 5.6 percent of the electrical heat input to the heater when operating continuously. This average heat input was determined for a 66-h period with the room air at about 75 °F and the water temperature maintained at 140 °F.

For the tests discussed in this paper, the heat release to the house by the hot water heater was assumed to be 600 Btu h<sup>-1</sup> without hot water usage and 1100 Btu h<sup>-1</sup> when hot water was being used where the additional heat is lost in the hot water pipes. The remaining heat consumed in heating the water was assumed to be lost to the sanitary drain.

The procedure followed in performing an operating schedule was to simulate the activities for the family members. The location of the occupants were traced throughout the house. The rooms of the house were equipped with arrays of electric lights for simulating body heat. Each array was continuously adjusted so that the heat given off by the bulbs would simulate the net metabolic heat produced by the occupants of the room. In similar manner, the doors were opened and closed and the fixtures and the appliances were operated, so as to be consistent with the particular daily living pattern.

The net daily energy inputs for the winter operating schedule are given in figure 34. The finely shaded area corresponds to the net body heat produced by the occupants, the cross-hatched area represents the heat release from the appliances, and the unshaded area depicts the energy given off by the electric lights. A morning peak of about 7000 Btu h<sup>-1</sup> occurs between 7 and 8 a.m., and an evening peak of about 7500 Btu h<sup>-1</sup> takes place during the nineteenth hour. The evening peak represents approximately one-fifth of the total energy supplied to the house. The net daily water consumption and net daily hot water usage are approximately 232 and 83 gal, respectively. The energy inputs for simulated summer operating schedule are plotted in figure 35. The uniformly distributed energy given off by the instrumentation was omitted from this

graph, since it is not really an integral part of the daily living pattern.

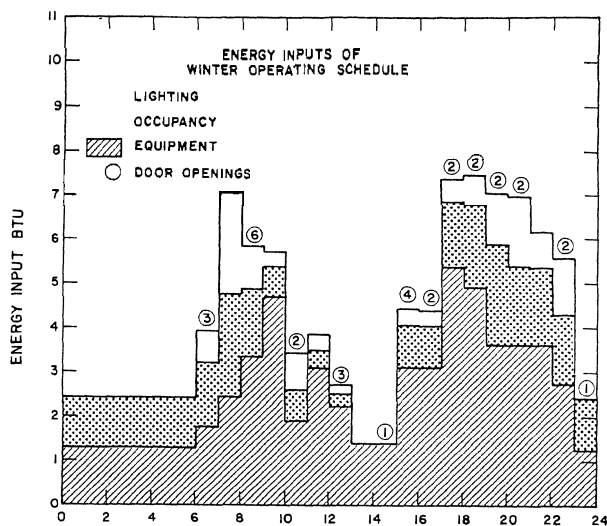

FIGURE 34. Energy inputs for simulated winter operating schedule.

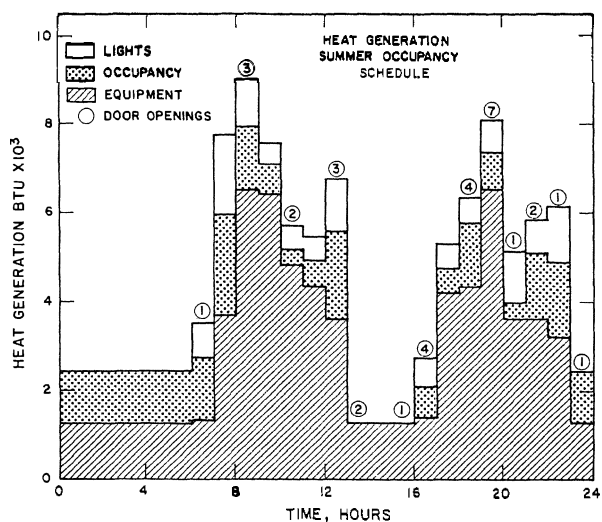

FIGURE 35. Energy inputs for simulated summer operating schedule.

### 5.3. Internal Mass of Test House

The mathematical model used in the computer program for predicting the thermal behavior of the townhouse treated the structure as an equivalent one room space. The heat exchange between adjoining rooms was negligible, owing to the very small temperature gradient across internal room partitions. All material inside

the shell of the structure acted as an internal mass, which absorbed and rejected heat as the temperature of the inside air fluctuated.

The wall partitions consisted of 2- by 4-in wood studs (placed 16 in on center) covered with 1/2-in gypsum board on both sides. The face area of one side of the internal wall partitions was approximately 1098 ft<sup>2</sup>.

The floor partitions from the floor of the upper module to the ceiling of the lower module consisted of 1/4-in carpet, 5/8-in plywood, 9-in wood equivalent through members (taken to be 16 in on center), and 1/2-in gypsum board. The face area of one side of the internal floor partitions was approximately 417 ft<sup>2</sup>.

The interior furnishings consisted of portable furnishings (such as furniture) and fixed furnishings (such as plumbing, heating and cooling ducts, range, refrigerator, cabinets, closets, hot water heater, furnace, bathroom fixtures, and the staircase). The portable furnishings were weighed on a scale, and their weight was 3182 lb. The weight of the fixed furnishings was estimated to be approximately 5000 lb. The net weight of interior furnishings was 8182 lb. Since the interior furnishings consist of a variety of materials of many different shapes and sizes, it was not practical to model them in an exact fashion. The effect of the interior furnishings was simulated in the computer program with an equivalent mass of wood. The face area and thickness of this equivalent mass were first estimated and then adjusted in the analysis as a result of a time-temperature plot of a pull-down test, so that the measured thermal mass effect agreed with the predictions of the computer program and thus could be later applied in performance tests.

#### 5.4. Performance of HVAC System Components

In order to perform prediction and evaluation analyses of the test house, it was necessary that the performance characteristics of the components of the HVAC (heating, ventilating and cooling) systems be determined. In some cases it was necessary to make adjustments to components to obtain a performance as set forth in the criteria or guidelines. The following sections describe the procedure and testing.

##### 5.4.1. Air Distribution System

In an attempt to obtain uniform temperature conditions in all rooms for both the heating and cooling conditions, it was necessary to balance the air distribution system by controlling the air delivery rate to each room by adjustments to the respective supply register dampers. Prior to each cyclic test, the system was operated and temperatures were measured at the center of each room. Damper adjustments were made. Time was allowed for the system to stabilize at a given condition and the process was repeated until a fairly uniform condition was achieved. To obtain nearly uniform temperature conditions for the winter heating cycles it was necessary to close off the registers in the two upstairs bedrooms. For the summer cooling cycles, the registers in the upstairs bedrooms were fully open.

The forced air blower of the air distribution system had two speeds. Operation of the blower at high speed occurred for summer cooling and "fan-on only" conditions that are obtained from manual switches located above the thermostat control. The low speed occurred during heating or furnace operation. Subsequent to the balancing of the system, air flow rates were determined at the air return for both the high and low speeds. The procedure for testing was to place an aluminum extension duct (fig. 16) in front of the return air register to confine the air flow prior to entering the register so that velocity measurements could be made. Air velocities were measured with a vane anemometer at the center of 12 subareas of the duct. The velocity readings were numerically integrated across the field of flow to give air flow rates. Air flow rates for high and low speeds were 1050 and 800 ft<sup>3</sup> min<sup>-1</sup>, respectively.

Velocity measurements at various locations within the house were made with two instruments. One instrument was a hot-wire anemometer capable of measuring velocities above about 75 ft min<sup>-1</sup>, and the other a hot-wire low velocity anemometer for velocities below 60 ft min<sup>-1</sup>. The various locations include the velocities at supply registers, around the globe thermometers, the occupied zone, living room windows, and at cracks at the bottom of the doors.

For velocities at the supply registers, velocity scans were made with the sensing element 2 in from the register. With a low-speed fan operation

the average velocities in feet per minute were: living room, 878; family room, 415; kitchen, 678; bedroom 1, 320; bedroom 2, 355; bedroom 3, 226; bedroom 4, 166; bathroom 1, 326; and bathroom 2, 116.

A velocity scan was made of the occupied zone which is defined as the zone from 3 in to 6 ft above the floor and 2 ft from the wall. With low-speed fan operation, no velocities exceeding 45 ft min<sup>-1</sup> were found. With high speed operation, two locations had velocities exceeding 45 ft min<sup>-1</sup>, one at the 6-ft level between the living and family room and 2 ft from the wall with the supply register of the family room, and the other 5 in from the floor and 2 ft from the entrance to bedroom 4. The velocities were 60 and 90 ft min<sup>-1</sup> for these locations, respectively.

Scans were made near the surface of the globe thermometers indicating that velocities were less than 10 ft min<sup>-1</sup> with and without fan operation.

At the center of the middle window in the living room, velocity measurements were made for 1/2-, 1- and 2-in distances from the window. For a thermostated inside temperature of 75 °F and an outside temperature of 20 °F, the velocity of the air (in ft min<sup>-1</sup>) flowing down the window was

distance from window, in	fan off	fan on
1/2	30-60	± 60
1	15-40	45-50
2	0-20	20-30

Velocity measurements were also made 2 in from and at a level with the nominal 1/16-in cracks at the bottom of the doors. Average velocities were 40 ft min<sup>-1</sup>

#### 5.4.2. Air Cooling Unit

A test was performed on the cooling unit supplied with the test house to determine the cooling capacity. With the unit operating continuously, readings were taken of air temperatures at the inlet and outlet of the unit, air velocities at the return of the air distribution system, relative humidities, pertinent watt-hour meters and air temperatures at the inlet and outlet of the condenser of the cooling unit. The air temperature difference across the cooling unit was 21.1 °F,

the air flow was 1004 cfm, the average room air temperature and relative humidity was 74.1 °F and 33.4 percent, respectively, and the average outside air temperature was 94.3 °F. There was no condensate from the cooling unit. For these conditions the cooling capacity of the unit was 22,900 Btu h<sup>-1</sup>.

The rate of electric energy consumption of the refrigeration unit was 3452 W, and that by the blower of the air distribution system was 504 W. The coefficient of performance for the refrigeration unit and the total system was 1.97 and 1.69, respectively, for the conditions of the test.

#### 5.4.3. Gas-Fired Furnace

A test was performed on the gas furnace to determine its efficiency under intermittent operation. The heat delivered to the house,  $q$ , by the furnace was computed for each operation of the forced air blower by the relation

$$q = \rho C_p \dot{V} \int_0^L (T_s - T_r) dt \quad (1)$$

where

$\rho$	= density of the air, lbm ft <sup>-3</sup>
$\dot{V}$	= air delivery rate, ft <sup>3</sup> min <sup>-1</sup>
$C_p$	= specific heat of air, Btu lb <sup>-1</sup> °F <sup>-1</sup>
$T_s$	= supply air temperature, °F
$T_r$	= return air temperature, °F
$t$	= time, h
$L$	= total time for blower operation, h

For the test, the return and supply air temperatures were recorded every 20 s for three heating cycles, for which 18 ft<sup>3</sup> of gas was consumed. Figures 36 and 37 show the results for one of these cycles. The gas input energy was 18,360 Btu with a higher heating value of 1020 Btu ft<sup>-3</sup> for the gas. The integral was evaluated for each blower on cycle, giving a net heat delivery of 11,788 Btu. The resulting efficiency is

$$\eta = \frac{11788 \times 100}{18360} = 64.2 \text{ percent}$$

The above calculated efficiency is defined for heat supplied to the air distribution system when the blower is operating and does not account for heat that may be transferred to the system by gravity effects when the blower is not operating. This would indicate that the calculated efficiency is low, but intuitively the gravity effects would at best make a very small increase.

An evaluation was made of the heat flowing up the furnace stack when the furnace and blower were not operating. Of the 52 min of three cycles, the blower and furnace were not operating for 35.5 min. In another determination, the pilot light consumed  $1.5 \text{ ft}^3 \text{ h}^{-1}$  for the off condition. If it could be assumed that during furnace operations the efficiency was 80 percent, then the flues losses during these periods are  $0.2 \times (18 - 1.5 \times 35/60) \times 1020 = 3491 \text{ Btu}$ . This leaves  $18,360 - 11,788 - 3491 = 3081 \text{ Btu}$  which must be accounted for by flue losses during the time when the furnace is not operating. During this period, the average temperature of the flue gases was about  $145 \text{ }^\circ\text{F}$  and the average velocity at the exit to the flue was  $550 \text{ ft min}^{-1}$ . For a  $51 \text{ }^\circ\text{F}$  crawl space temperature the heat loss to the flue during the 35.5 min is  $2883 \text{ Btu}$  which for this rough calculation indicates an unaccounted for  $198 \text{ Btu}$  and a possible increase in the efficiency to 65.2 percent.

Another rough estimate of the efficiency of the gas furnace with intermittent operation can be made from the tests where gas and electric heating were used (simulated Kalamazoo weather cycle). For these tests the heating load was fairly constant during the period from 0000 to 0600. For the electric heating test, the average energy input was  $22,050 \text{ Btu h}^{-1}$  with a temperature difference between inside and outside of  $74 \text{ }^\circ\text{F}$ ; for the gas heating test the values were  $32,100 \text{ Btu h}^{-1}$  and  $71 \text{ }^\circ\text{F}$ , giving a value for efficiency as

$$\eta = \frac{22,050 \times 71 \times 100}{32,100 \times 74} = 65.9 \text{ percent.}$$

For computer predictions of the total energy requirements a value of 65 percent for the efficiency of the gas-fired furnace under intermittent operation was used.

## 5.5. Thermal and Physical Properties

The thermal and physical properties of the building materials needed for use in the computer program were obtained from available literature and are presented in the following table.

TABLE 5. *Thermal and physical properties*

	Thermal conductivity $\text{Btu h}^{-1}$ $\text{ft}^{-1} \text{ F}^{-1}$	Density $\text{lb ft}^{-3}$	Specific heat $\text{Btu lb}^{-1}$ $\text{F}^{-1}$
Gypsum board	.12	58.	.26
Glass fiber insulation	.023	2.0	.22
Plywood	.08	34.	.38
Roofing felt	.046	63.	.35
Asphalt shingles	.084	73.	.2
Wood member	.07	26.	.38
Redwood	.07	25.5	.387
Nylon carpet	.07	20.	.21
Wood fiber board	.028	15.	.34
Asphalt tile	.09	80.	.21

The coefficients of heat transfer at the inside and outside surfaces were the most difficult of the numerous parameters to define for this experimental work. Values given in literature are usually determined from steady-state conditions whereas these test conditions were dynamic and the coefficients vary with orientation of surfaces, direction of heat flow, temperature of surface and air motion at the surfaces. Values for the surface coefficients of heat transfer at the various surfaces (except for windows) were selected as shown in the following table and used in the computer program as constants for the time period of a test.

TABLE 6. *Selected heat transfer coefficients,*  
 $\text{Btu h}^{-1} \text{ ft}^{-2} \text{ F}^{-1}$

	Inside Surface	Outside Surfaces
Wall	1.10	1.47
Roof	1.64	2.00
Floor	1.08	1.10

In general, these values are based on a value of 0.9 for the radiation component of heat transfer and time-averaged temperature differences

between surfaces and adjacent air. Reasonable variations in these coefficients as high as 20 percent have shown a negligible effect on results from the computer program, due to the fact that the thermal resistance of surface films is generally comparatively small.

The above statement is not true for the double-pane windows used in all tests because the surface films comprise a larger portion of the overall thermal resistance due to the relatively high thermal conductance of the two window glasses. Because temperature measurements were made on the inside and outside of all windows, it is possible to determine an average thermal transmittance for the windows, if the thermal conductance of the glass and airspace can be reasonably estimated.

Several measurements were made to determine the thicknesses of the glass and airspace. The thickness of the airspace was 0.2 in and that for the glass was 0.125 in. Due to the small thickness of the airspace, the convective effect was assumed negligible and the heat transfer due to conduction was taken to be  $0.74 \text{ Btu h}^{-1} \text{ ft}^{-2} \text{ F}^{-1}$ . The conductance of the airspace is the sum of the conduction, convection, and radiation components, or

$$C_a = 0.74 + .00617 \left( \frac{T_a + 460}{100} \right)^3 \quad (2)$$

where  $T_a$  is the average temperature of the airspace. The thermal conductance of the two panes of glass and airspace as series resistance is given from the relationship

$$\frac{1}{C} = \frac{1}{C_a} + \frac{0.25}{4} \quad (3)$$

The air-to-air thermal transmittance is then calculated from the relationship

$$U = \frac{C(T_{wi} - T_{wo})}{T_{ai} - T_{ao}} \quad (4)$$

where the subscripts  $i$  and  $o$  are inside and outside conditions, respectively, the subscript  $w$  refers to window surfaces, and the subscript  $a$  refers to air temperatures. Values of  $U$  were calculated for the eight window systems of the test house for each scan of several tests and averaged on an area

basis. A plot of the results of these calculations against air temperature difference between inside and outside shows some scatter but seems to indicate that the thermal transmittance for the windows is invariant with the temperature difference. An average value of thermal transmittance  $U=0.46 \text{ Btu h}^{-1} \text{ ft}^{-2} \text{ F}^{-1}$  was used for the computer predictions.

For the computer program, the heat capacity effects of the doors, windows, and window panes were assumed to be negligibly small and only the thermal resistance of these components were used. The thermal resistance for doors was calculated by series resistance using surface heat transfer coefficients for walls from table 6. The thermal transmittance of the aluminum window frames was assumed to be  $0.65 \text{ Btu h}^{-1} \text{ ft}^{-2} \text{ F}^{-1}$ , where the resistance to heat flow through the framing material is assumed to be negligibly small.

The areas used for computing heat flows through the building components were the inside areas of each of the components. These areas and their respective calculated thermal transmittance are summarized in table 7 below.

TABLE 7. Areas and thermal transmittances of building components

Building components		Thermal transmittance	
		Area ft <sup>2</sup>	Btu h <sup>-1</sup> ft <sup>-2</sup> F <sup>-1</sup>
Roof	Insulation	734.3	.045
	joist	83.7	.110
Walls	Insulation	1108.8	.063
	stud	166.1	.138
Carpet floor	Insulation	468.2	.033
	joist	54.3	.086
Tile floor	Insulation	247.7	.034
	joist	28.8	.087
Windows		137	.46
Doors		36.4	.20
Aluminum framing		21	.65
Party wall	Insulation	208.8	.019
	stud	31.2	.022

## 5.6. Description of Tests

The following sections give a brief, identifying description of the principal tests performed on the test house. For most tests, it was necessary to maintain cyclic temperature patterns for a period of 2 to 3 days before a final set of data was taken. This conditioning period was deemed sufficient to eliminate transient heat flows thereby giving only heat flows that occur in a steady periodic condition. The temperatures occurring in the crawl space are an exception to this, because they are affected by the temperature of the earth below. A discussion of this will be found in another section.

A complete set of data for each test consisted of recording the digital output from analog signals of 241 sensing elements (thermocouples, etc.) every 30 min for the duration of a test. The recorded data was fed into a data reduction computer program to process the data into temperatures, relative humidities, etc. The converted data was then transferred to magnetic tape for use in analyses, and plotting as temperature and heat flow patterns.

### 5.6.1. Description of Winter Tests

A summary of the tests performed on the test house that simulate winter conditions is given in the following table.

TABLE 8.

Test	Outside temp. weather cycle	Range °F	Simulated	
			Type of heating	occu-pancy
1	Kalamazoo	1 - 38	Electric	yes
2	Kalamazoo	1 - 38	Gas	yes
3*	Kalamazoo	1 - 38	Electric	no
4	Macon	27 - 65	Gas	yes
5*	Macon	20 - 65	Electric	no
6	BSS 45	17 - 70	Electric	no
7	Steady state	28	Electric	no

\*Night temperature setback test.

The outdoor temperature patterns for Kalamazoo and Macon were the corresponding averaged sol-air temperature cycles defined in section 5.1. The cycle termed "BSS 45" is shown in the section on discussion for test 6 and refers to a simulated outdoor weather cycle used in tests

on an experimental masonry building [2]. Simulated occupancy of tests 1, 2, and 4 refers to a winter operating schedule as defined in section 5.2. Tests with no simulated occupancy were performed without the heat generating loads due to appliances and lighting. For tests employing electric resistance heating, both the combustion air inlet and the chimney flue were sealed.

Tests 3 and 5 were special purpose tests for determining the reduction of energy usage due to "nighttime setback" of the thermostat. Generally these tests were performed for four identical diurnal cycles in which during two of the cycles the thermostat control was moved from a setting of 75 to 65 °F for a period of 8 h and then reset to 75 °F again. During the other two cycles the thermostat setting was unchanged. The difference in the readings for the energy consumption during the appropriate time periods gives the reduction in energy consumption due to "nighttime setback."

For the steady-state test 7, the outdoor air temperature was maintained continuously at about 28 °F for a 4-day period. The rate of heat output of the electric resistance heating elements was adjusted to provide a continuous operation of the heaters and fan and an indoor temperature of about 75 °F. The purpose of this test was to provide information concerning the thermal transmittance of the house and its components in order to corroborate thermal property values used in the prediction analysis.

### 5.6.2. Description of Other Tests

Three additional tests were performed; namely, a pull-down test, a summer cooling test, and a fall test. A pull-down test (test 8) is defined as a test for which the inside air temperature reduction of a test house is obtained in response to a sudden decrease in the outside air temperature. The lower level outdoor temperature is maintained for a prolonged period of time and the temperature inside the house drops as heat is lost.

Tests 9 and 10 were performed with simulated occupancy schedules. Test 9 was a summer cooling test using the outside air temperature cycle computed for the Kalamazoo design condition of figure 33. Test 10 was a fall test using the outside air temperature cycle computed for the Macon condition of figure 31.

## 6. Results and Discussion

In the following sections, results and discussion are presented for various aspects of 10 tests, such as the comparison of measured and computer-predicted heating and cooling loads, performance characteristics of the heating, ventilating system, and special purpose tests—pull-down, steady-state and nighttime setback of the thermostat.

### 6.1. Winter Heating Tests

For the winter tests 1, 2, 4, and 6, the test house was exposed to a dynamic daily sol-air temperature cycle, while the interior of the test house was maintained at approximately 75 °F by the operation of its furnace system. During these tests the rate of energy input to the furnace system and the rate of electrical input energy (other than heating energy) were measured, and these values were compared to corresponding predicted values of the NBSLD program. For tests 1, 2, and 4 the activities and occupancy of a six member family were simulated with the operating schedule described in section 5.2. Test 6 was performed without simulated occupancy.

The measured indoor temperature, obtained by averaging the temperatures sensed by the indoor air thermocouples located on the thermocouple strings of the center of the rooms, contained many fluctuations due to the intermittent operation of the furnace system. It was, therefore, necessary to apply a harmonic analysis to these sets of data. By maintaining only the first four terms in the resulting series, a smoothed variation of inside air temperature with time was obtained for each of these sets of data. The outside air and the crawl space temperatures needed for the analysis were obtained by averaging the temperatures sensed by the outside air thermocouples and crawl space thermocouples, respectively.

In test 1, the test house was exposed to a Kalamazoo winter design day (sec. 5.1.). The measured daily variation in the outside air, crawl space air, and the inside air temperature is given in figure 38. For this test the test house was heated with electric resistance heating elements located in the warm air outlet of the furnace system. A comparison between the measured and

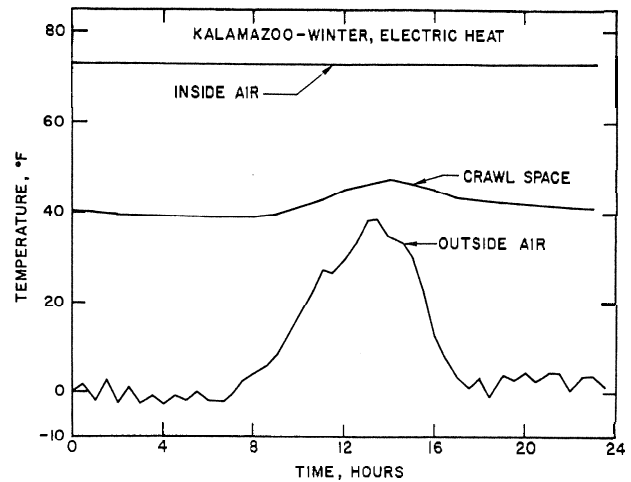

FIGURE 38. Measured daily variation in the outside, crawl space and the inside air temperature for test 1.

calculated rate of energy input to the furnace system is given in figure 39. The agreement between the measured and predicted peak heating energy input rates is very good. The predicted peak value is 4.5 percent higher than the measured value. A comparison between the measured and predicted rate of electrical energy input (other than heating energy) is given in figure 40. This is the electrical energy required for the lighting, equipment, and simulating the heat release of the occupants. Since exact values for the hourly electrical energy consumption for lighting, equipment, and occupancy were fed into the NBSLD program, difference, between these

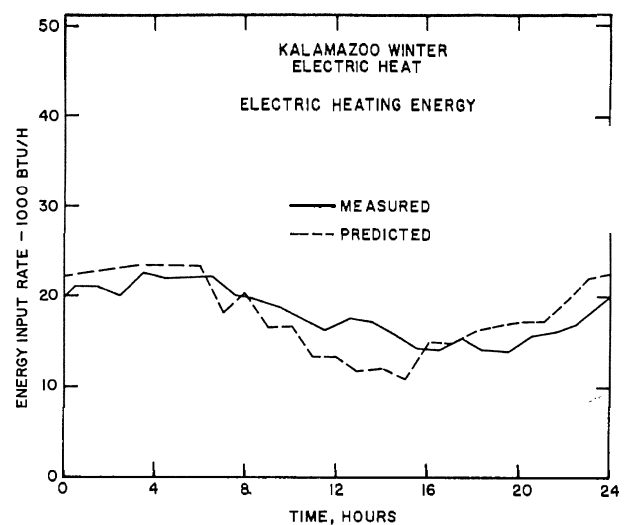

FIGURE 39. A comparison between the measured and calculated rates of energy input to the furnace system for test 1.



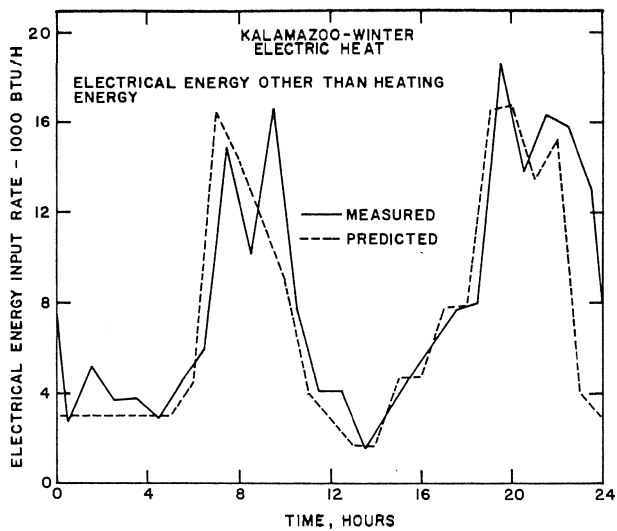

FIGURE 40. A comparison between the measured and calculated rates of electrical energy input (other than heating energy) for test 1.

two electrical input rate profiles should be attributed to the predictive capability of the mathematical model used to calculate energy for hot water heating. The mathematical model contains algorithms for converting hot water consumption into energy requirements for hot water heating. A comparison between the measured and predicted rate of total energy input to the test house is given in figure 41.

Test 2 was identical to test 1, except that the test house was heated with its gas-fired furnace system, instead of electrical heaters. The measured daily variations in the outside air, crawl space air, and the inside air temperatures for this test are given in figure 42. A comparison

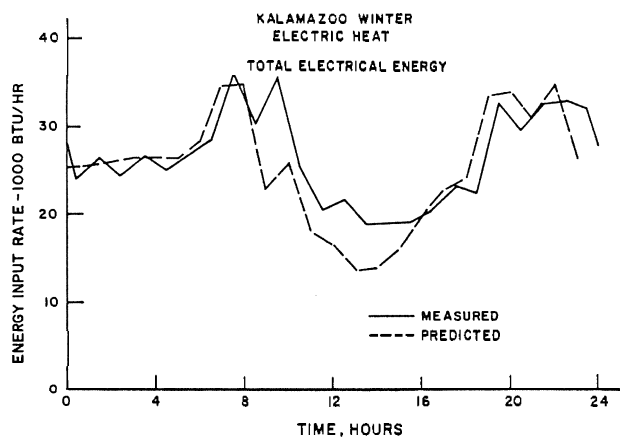

FIGURE 41. A comparison between the measured and calculated rates of total energy input to the test house for test 1.

between the measured and predicted rates of energy input to the furnace system are presented in figure 43. For the case of a gas-fired furnace system, the NBSLD program calculates the rate of gas energy input by dividing the heating load by the efficiency of the gas furnace system. The efficiency of the gas furnace system was determined by laboratory measurements to be 0.65, and this value was used in the computer program. A comparison between the measured and predicted rates of electrical energy input (other than heating energy) is given in figure 44, and a comparison between measured and predicted rates of total energy input to the test house are presented in figure 45.

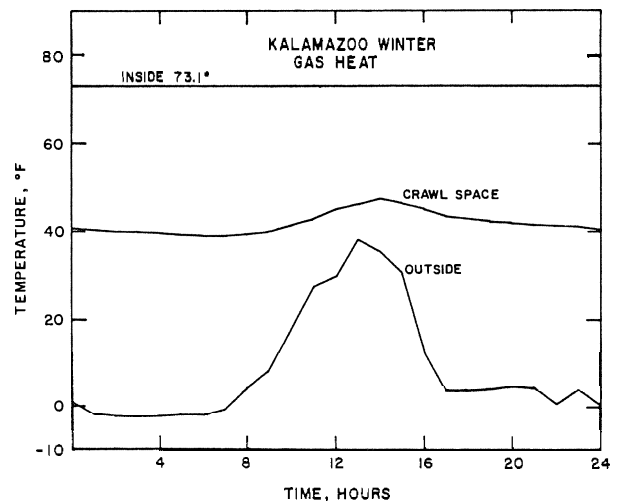

FIGURE 42. Measured daily variation in the outside air, crawl space air, and the inside air temperature for test 2.

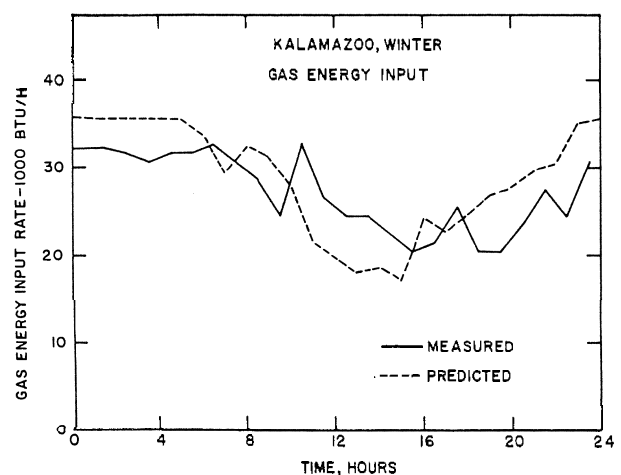

FIGURE 43. A comparison between the measured and calculated rates of energy input to the furnace system for test 2.

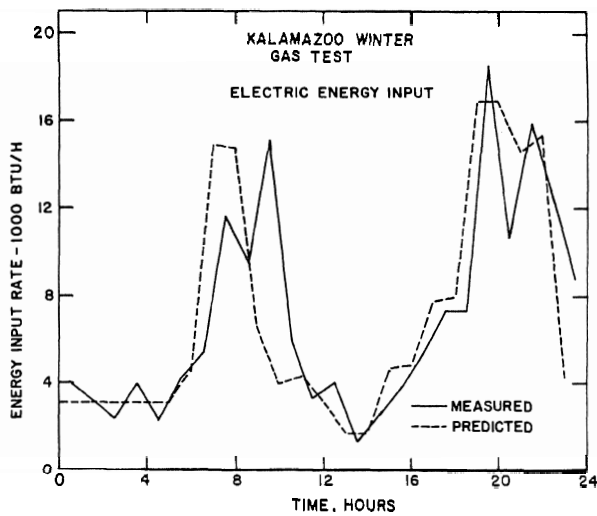

FIGURE 44. A comparison between the measured and calculated rates of electrical energy input (other than heating energy) for test 2.

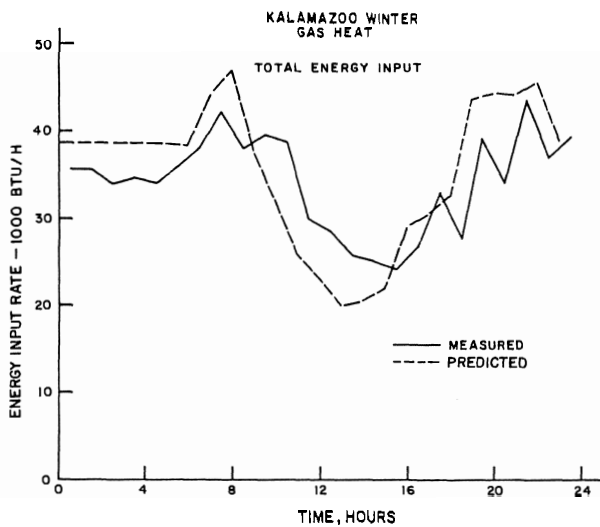

FIGURE 45. A comparison between the measured and calculated rates of total energy input to the test house for test 2.

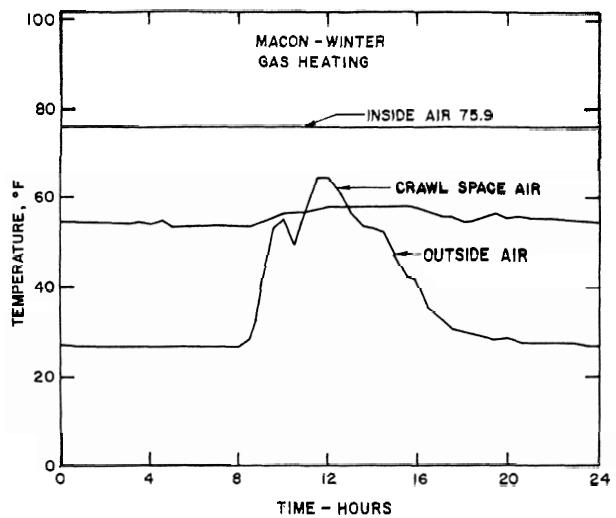

FIGURE 46. Measured daily variation in the outside air, crawl space air, and the inside air temperature for test 4.

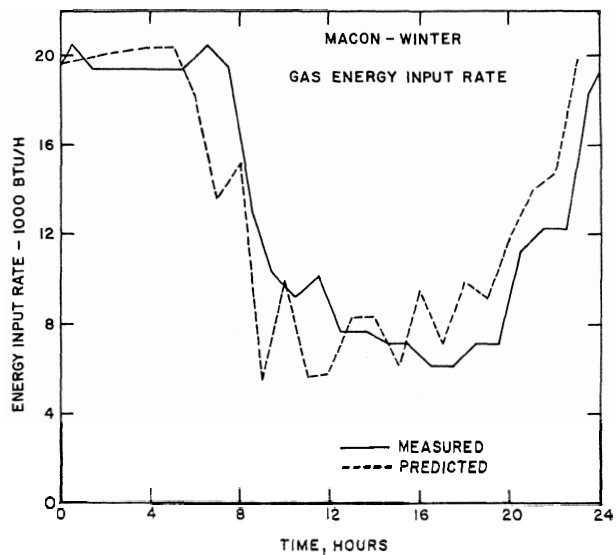

FIGURE 47. A comparison between the measured and calculated rates of energy input to the furnace system for test 4.

For test 4 the test house was heated with its gas furnace system and exposed to a Macon design day temperature cycle. Measured daily variations for this test are given in figure 46. Comparisons between measured and predicted values for the rates of energy input to the furnace system, rates of electrical energy (other than heating energy), and rate of total energy input to the test house are given in figures 47, 48, and 49, respectively.

For test 6, the test house was exposed to an outside air temperature cycle (fig. 50) similar to that used for tests on an experimental masonry

building (test 10, BSS 45 [2]). Heating was accomplished with electric heaters. This test was performed without simulated occupancy, so that the rate of heat loss from the test house was equal to the rate of total energy supplied to the house. A comparison between measured and predicted heat loss rate for test 6 is shown in figure 51. Also shown in this figure is the time-varying heat loss rate that is calculated by a steady-state procedure (see equation (5) given below). A phase difference between measured and predicted heating load was observed as the heat loss rate decreased to a mini-

mum. This phase difference was also observed in tests on an experimental masonry building [2].

It was pointed out in reference [2] that steady-state procedures may predict maximum heat loss rates that are too high, since these methods do not take into account the dampening effect caused by the thermal mass of a building. The maximum heat loss rates for tests 1, 2, 4, and 6 were calculated by the steady-state relation:

$$q = (T_i - T_o) [\sum U_n A_n + 1.08V] + (T_i - T_c) \sum U_m A_m \quad (5)$$

where

- $q$  = heat loss rate, Btu h<sup>-1</sup>
- $U$  = thermal transmittance, Btu h<sup>-1</sup> ft<sup>-2</sup> F<sup>-1</sup>
- $A$  = surface area, ft<sup>2</sup>
- $T_i$  = inside air temperature, °F
- $T_o$  = minimum outside sol-air temperature, °F
- $T_c$  = crawl space temperature, °F
- $V$  = air infiltration rate, ft<sup>3</sup> min<sup>-1</sup>

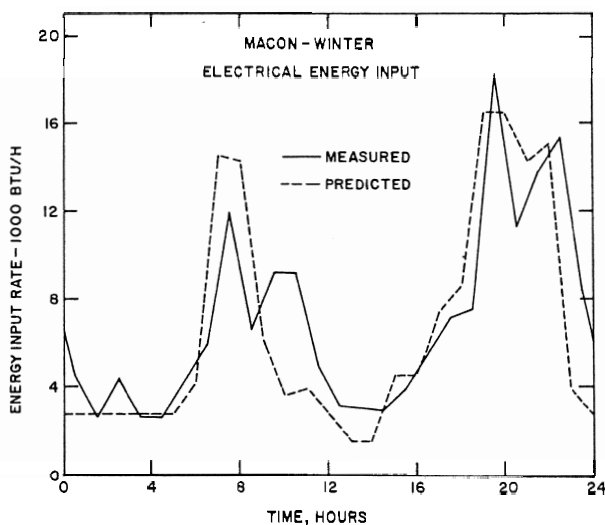

FIGURE 48. A comparison between the measured and calculated rates of electric energy input (other than heating energy) for test 4.

The subscript  $n$  refers to the building components such as walls and windows, and the subscript  $m$  refers to the components of the floor as given in table 7. Air infiltration rates were based on the results given in appendix A. These steady-state

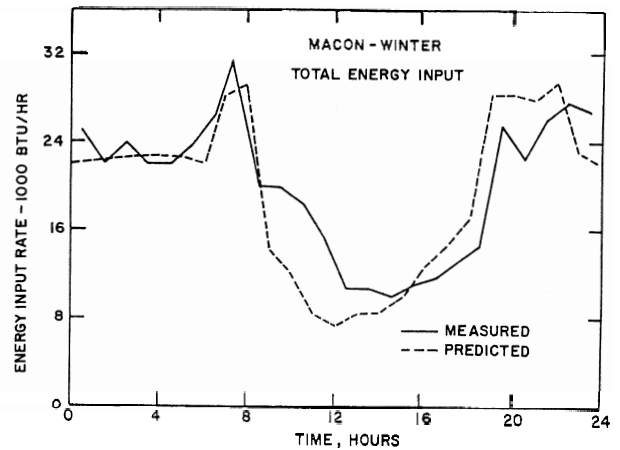

FIGURE 49. A comparison between the measured and calculated rates of total energy input to the test house for test 4.

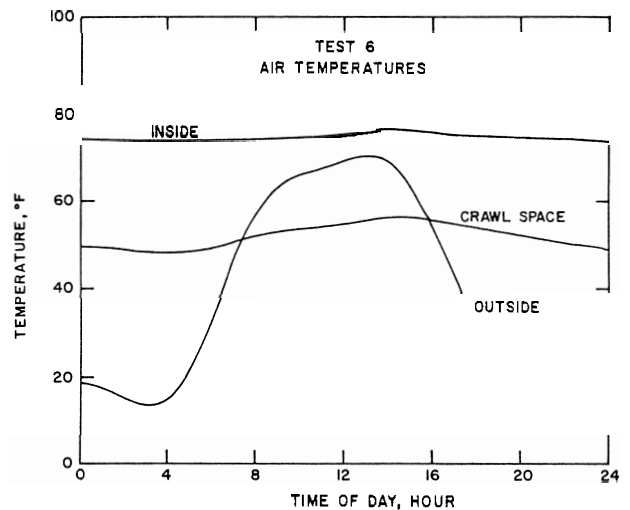

FIGURE 50. Measured daily variations in the outside air, crawl space air, and the inside air temperature for test 6.

heat loss rates are compared to corresponding values calculated by the NBSLD computer program and corresponding measured values in table 9. The measured heat loss rates were taken

TABLE 9. Maximum heat loss rates, Btu h<sup>-1</sup>.

Test no.	Steady-state procedure	NBSLD method	Measured values
1	27,422	27,310	26,080
2	25,767	25,600	24,100*
4	16,193	15,697	14,950*
6	20,514	17,950	17,400

\*Based on efficiency of .65 for gas-fired furnace

to be equal to the total amount of heat released inside the test house at the time of the maximum heat loss rate.

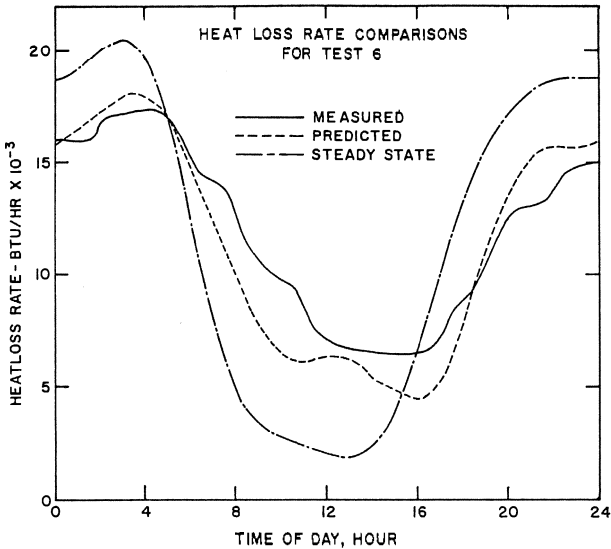

FIGURE 51. A comparison between the measured rates of heat loss for test 6 to the corresponding values by NBSLD program and steady-state procedures.

## 6.2. Summer Cooling Test

Test 9 was a summer cooling test where the outside air temperature varied in a manner similar to the sol-air temperature calculated for the Kalamazoo summer condition described in section 5.1.2. The average inside, outside and crawl space temperatures for this test are shown in figure 52, and the rate of condensate collection is shown on figure 53. The average relative humidity in the house was about 42 percent, being somewhat higher in the evening hours when baths and showers were used. The dew point temperature of the outside air was maintained at about 62 °F, except for the period from 1000 to 1600 where it was maintained at about 71 °F.

For the time period from 1130 to 2130 the cooling system was operating continuously for which the power consumption of the air conditioning unit was about 3978 W (13,578 Btu·h<sup>-1</sup>). The air temperatures entering and leaving the condenser coil averaged 99 and 140 °F, respectively, during this time period. An

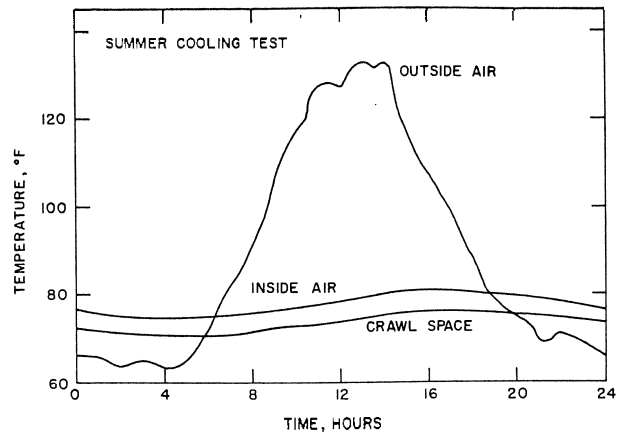

FIGURE 52. Measured daily variation in outside, inside crawl space air temperature for test 9.

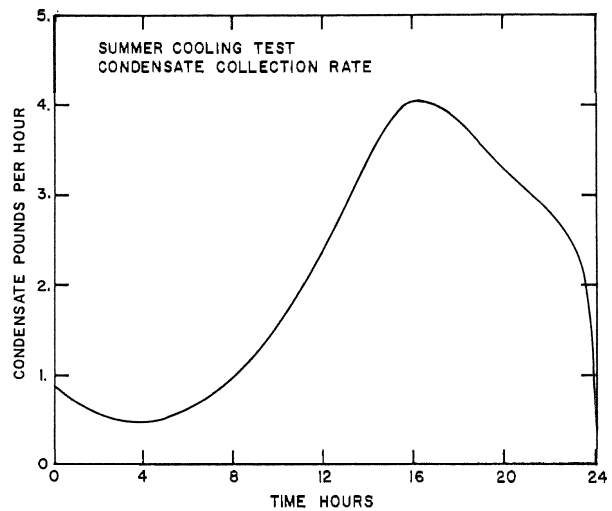

FIGURE 53. Condensate collection rate for test 9.

approximate value for heat removed by the evaporator of 20,000 Btu·h<sup>-1</sup> was determined from temperature drop across the evaporator, condensation and heat from the blower. This gives a coefficient of performance for the refrigeration unit of 1.47.

This gives a considerably lower value than the value of 1.97 previously stated for a test performed on this unit. During that test the power consumption was 3452 W and the entering and leaving condenser temperatures were 97 and 125 °F, respectively. This indicates for the summer test that the condenser was operating at a much higher temperature and, therefore, at a reduced efficiency. A rule of thumb calculation for the

coefficient of performance would be  $1.97 \times (3452/3987)^2 = 1.48$ , which is close to the value derived from the approximate heat balance.

For the summer operating condition described in section 5.1.2. and using a coefficient of performance of 1.47, the computer predicted energy use by the cooling equipment is shown in figure 54 as well as that measured during the test. For the time period 1200 to 2200 the predicted values lie below the measured curve. An explanation for a portion of this discrepancy may be an unaccounted for heat gain to the kitchen area from the refrigeration compressor and condenser unit that was located in a closet in the kitchen. Noticeably high air temperatures were recorded in the vicinity of this unit.

### 6.3. Fall Test

The outdoor air temperature for test 10 varied in a manner similar to the sol-air temperature calculated for the Macon fall condition described by figure 30. The average inside, outside and crawl space temperature are shown in figure 55. Tests were performed concurrently with this test involving the use of the plumbing system of the house. For this reason, the operating schedule was as shown in figure 56, which reflects an increased usage of the washer, dryer, and dishwasher and an increase in door openings. But to a high liberation of water vapor from the washer, dryer, and dishwasher, the condensation collection rate was as high as 3 lb/h during the daytime hours.

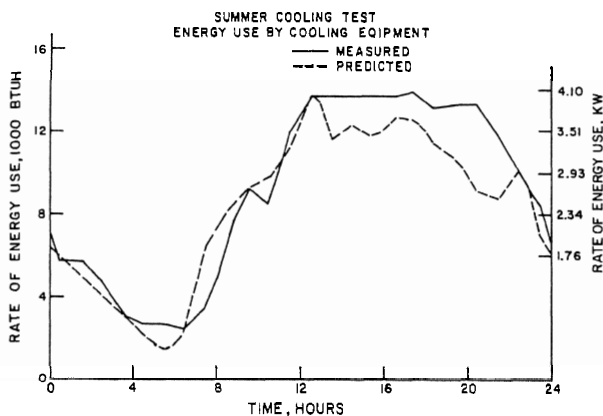

FIGURE 54. Energy consumed by air cooling equipment for test 9.

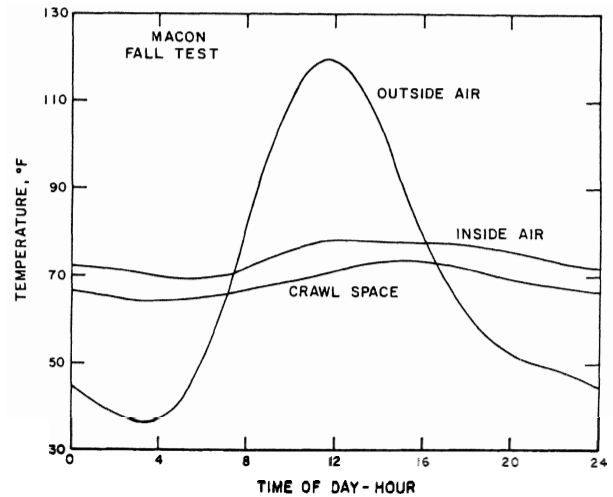

FIGURE 55. Measured daily variation in inside, outside, and crawl space air temperatures for test 10.

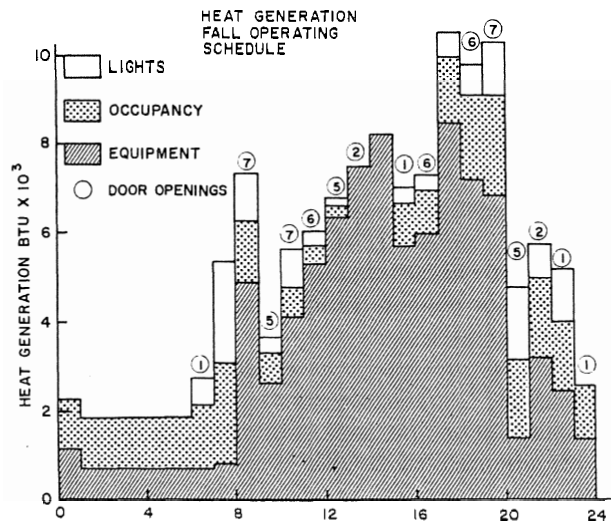

FIGURE 56. Operating schedule for Macon fall (test 10).

During this test, only the air cooling unit was used. It was not deemed necessary to use the heating unit because the inside air temperature did not drop below 69 °F at night. Shown in figure 57 is the computer predicted energy use by the air cooling equipment as well as that measured during the test. As in the summer cooling test, the predicted values lie below the peak measured value and appear to be out of phase as is also shown in the winter heating tests.

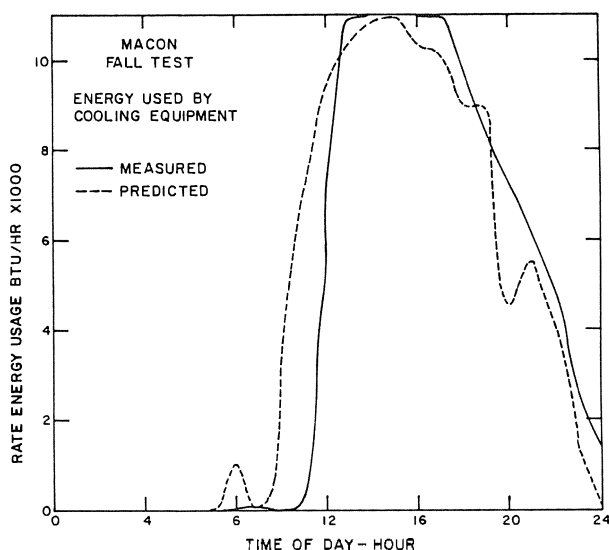

FIGURE 57. Energy consumed by air cooling equipment for test 10.

#### 6.4. Comparison Summary of Predicted and Measured Energy Consumption

Of particular interest is the capability of the NBSLD program to predict maximum heating and cooling loads, since these values are used to select appropriately sized heating and cooling equipment. Also of interest, is the capability of the NBSLD program to predict daily heating and cooling energy requirements, so that energy consumption for heating and cooling may be determined.

Comparisons between measured and calculated maximum heating and cooling energy consumption for the computer validation tests are summarized in table 10.

From table 10, it can be seen that NBSLD predicted maximum heating and cooling consumption rates within a difference of 9.2 percent from the measured values. The average difference for predicting maximum energy input rates was 2.9 percent. In predicting daily energy requirements the maximum difference was 8.2 percent, whereas the average difference was 4.5 percent.

#### 6.5. Pull-Down Test

In the pull-down test the townhouse was maintained at a constant chamber air temperature of 77 °F for 3 days to obtain a uniform temperature throughout the house. The chamber air temperature was reduced from 77 to 33 °F in 3 h and maintained at 33.6 °F for an additional 93 h. Inside the house the blower of the air distribution system was operated continuously to provide mixing of the inside air. The internal heat generation rate by the blower and instrumentation located inside the house was constant at 685 W or 2339 Btu/h<sup>-1</sup>. The temperature inside the house decreased as the house lost heat to the chamber air.

Figure 58 is a plot of the measured values for the inside, outside, and crawl space temperatures. The measured inside air temperature at any instant of time was obtained by averaging temperatures recorded from thermocouples located at the geometric center of the rooms. Two days were required to reduce the inside air temperature from 77 to 53 °F and an additional 2 days were required to drop the temperature from 53 to 49 °F. The slow decrease

TABLE 10. Comparison summary of predicted and measured energy consumption

Test	Maximum heating/cooling energy consumption, Btu/hr			Daily heating/cooling energy consumption, Btu per day		
	Predicted	Measured	% difference	Predicted	Measured	% difference
Heating Test 1	23,400	22,600	+ 4.0	434,000	436,000	- 0.5
Heating Test 2	35,700	32,700	+ 9.2	684,000	652,000	+ 4.9
Heating Test 4	20,300	20,400	- 0.5	319,000	327,000	- 2.5
Heating Test 6	18,000	17,400	+ 3.4	273,000	286,000	- 4.3
Summer cooling test	13,600	13,600	0.0	201,100	219,100	- 8.2
Fall test	10,950	11,000	- 0.45	107,300	100,650	+ 6.61

in temperature is attributed to decreased temperature difference between inside and outside, to the large amount of internal mass (interior walls, floors, and furnishings) which release heat at a slow rates and to the crawl space temperature which in latter portions of the test was greater than the inside air temperature indicating that heat was flowing into the house from the crawl space. The earth below the crawl space takes a long time to come into equilibrium with the outside air temperature and is therefore able to maintain the crawl space at a temperature above the outside temperature for fairly long periods of time. This was observed for all tests.

An initial computer prediction for the pull-down test assumed that the air infiltration rate was constant at 0.75 air changes per hour and that the internal furnishings (8200 lb) was simulated by an equivalent weight of wood 2-in-thick with a surface area of 1892 ft<sup>2</sup>. The results for the initial prediction are shown in figure 58. Subsequent testing (app. A) showed that air infiltration behaved by the relation,

$$I = 0.117 + 0.0108 \Delta T \quad (6)$$

where  $\Delta T$  is the temperature difference between inside and outside. With this correction, the predicted temperature variation is also shown on figure 58. This indicates that the thermal mass was coming into thermal equilibrium with the inside air at too fast a rate. The agreement shown on figure 58 was found by assuming an equivalent weight of wood with 1.5 ft thickness with a surface area of 210 ft<sup>2</sup>.

From the thermal point of view a building can be defined by thermal behavior parameters such as the equivalent thermal resistance of the building or the thermal time constant of the building as a whole. As a parameter, the thermal resistance defines the ability of the building to restrain heat flows with an applied temperature difference between the inside and outside. For the case of a dynamic outside temperature variation, thermal resistance values are not a sufficient characterization and the heat capacity of building elements must be considered. The thermal time constant is a dynamic parameter defined as the time in which the internal air temperature reaches 63 percent of its steady-state value when an external step

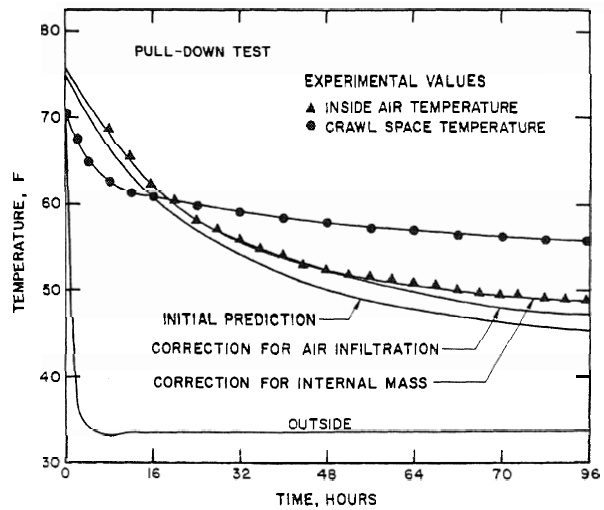

FIGURE 58. Measured and predicted temperatures for pull-down (test 8).

function is applied. From the results of the pull-down test, the thermal time constant for the test house is approximately 24 h.

## 6.6. Nighttime Setback Tests

Tests 3 and 5 were special purpose tests to determine the reduction in energy usage due to lowered inside temperature at night. To provide meaningful results it was necessary that the test house be exposed to identical diurnal outside air temperature cycles and operation during each test. Outside air temperatures for the periods of the tests are shown on figures 59 and 60 which are the simulated weather cycles for Kalamazoo, Mich. and Macon, Ga., respectively. Also on these plots are shown the temperatures at the thermostat and in the crawl space below the house. The cycles as shown in these plots are from 10 p.m. (2200) to 10 p.m. the next day.

The first cycle is with no "setback" of the thermostat and the indoor air temperature is maintained at about 75 °F continuously. At the start of the second cycle the thermostat was lowered 10 °F from 75 to 65 °F and the indoor air temperature dropped as shown until the thermostat called for heat. After an 8-h period, the thermostat was raised to 75 °F calling for continuous heating in the house until the indoor air temperature reached 75 °F. The third cycle is a repeat of the second cycle. Before each of the

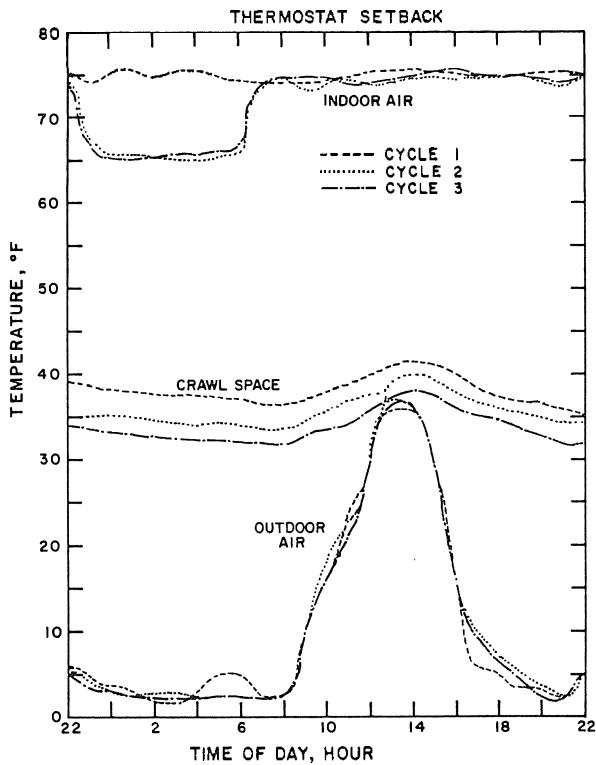

FIGURE 59. Cyclic variations for outside thermostat and crawl space air temperature for test 3.

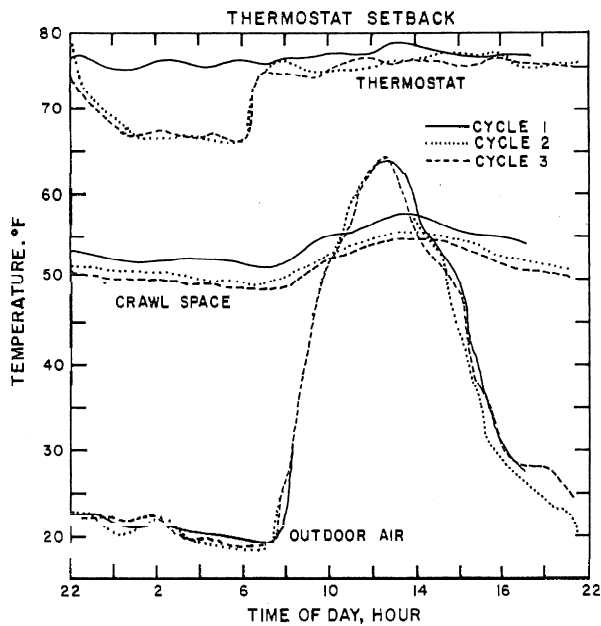

FIGURE 60. Cyclic variations for outside thermostat and crawl space air temperature for test 5.

two night setback tests, the chamber was maintained at 35 °F and the indoor temperature at 75 °F for 2 days, and then one complete diurnal cycle of outdoor temperature preceded the three cycles. The purpose was to eliminate transient heat flows and insure steady periodic conditions. Table 11 is a summary of the results for the night setback tests. For each cycle, measurements were recorded of the electrical energy usage. The percent energy reduction is taken as the difference between the energy usage without setback and with setback divided by the energy usage without setback multiplied by 100.

The furnace on-time in minutes for each hour was determined from recordings of an event meter. Results for the two tests are shown in figures 61 and 62. An approximate method for calculating energy reduction is to substitute total furnace on-time for energy usage.

Because these tests were performed under steady-periodic conditions, the total amount of heat for any diurnal cycle may be calculated using eq (5) and the average temperature differences given in table 11. Results of the calculations are given in table 11. Note that at the smaller inside to outside temperature differences (Macon cycles) the calculated reduction in energy usage does not compare as favorably with the measured reductions and the heat on-time reductions. The reason for this is believed to be the sensitivity of the air infiltration term in eq (5) at the smaller inside to outside temperature difference.

The calculated values of KWH are within 2 percent of the measured values and it appears reasonable that corrections can be made to the measured values due to the change in the average crawl space temperature from cycle to cycle. Adjustments can be made by using the differences between the last term of eq (5) for the various cycles. The adjusted values for percent energy savings are also given in table 11.

Using cycle number 1 as the control condition, the average outside air temperature for the other two cycles did not vary by more than 1 °F. This is not true for the average crawl space temperature which decreased from cycle to cycle. The reason for this is that the earth below the crawl space takes a long time to come into equilibrium with the outside air temperature cycle and is, therefore, able to maintain the crawl space at



TABLE 11. Results of nighttime setback tests

	Test No. 3 Kalamazoo Cycles			Test No. 5 Macon Cycles			
	1	2	3	1	2	3	
Duration of setback, hours per day	0	8	8	0	8	8	
Cycle measured energy usage, KWH	156.5	142.4	144.9	102.5	90.7	92.3	
Reduction in energy usage	%	-	9.0	7.4	-	11.5	10.0
Heat on-time, min. daily cycle	846	765.5	781.2	562	496	503	
Approx. reduction in energy usage	%	-	9.5	7.7	-	11.7	10.5
Calculated energy usage, eq (5), KWH	158.5	144.6	146.4	100.5	92.0	91.7	
Calculated reduction in energy usage	%	-	8.8	7.6	-	8.5	8.8
Temperature at thermostat	°F						
Average during cycle		7.53	71.4	71.8	76.1	73.1	72.7
Average before setback		-	74.7	74.3	-	76.0	75.5
Average setback (heat on)		-	65.9	65.9	-	66.9	66.1
Effective setback		-	8.8	8.4	-	9.1	9.4
Outside air temperature	°F						
Average during cycle		10.1	10.8	10.7	34.0	33.4	33.8
Average during setback		-	2.9	2.5	-	20.6	20.9
Average crawl space temperature	°F	47.6	45.6	43.5	53.7	52.2	51.4
Temperature difference	°F						
Inside to outside		65.2	60.6	61.1	42.1	39.7	38.9
Inside to crawl space		27.7	25.8	28.3	22.4	20.9	22.9
Adjusted reduction of energy usage for cycle to cycle change in crawl space temperature	%		9.3	7.9	-	11.8	10.4

temperatures above the mean temperature of the outside air for fairly long periods of time. The effect of the decreasing crawl space temperature during the test period was to increase the heat loss from the test house. Therefore, the measured energy savings would have been larger, if the crawl space temperature variation had been maintained the same for each 24-h period.

### 6.7. Steady-State Winter Test

For the steady-state winter test (test 7), the outside air temperature was maintained at approximately 27.9 °F for a 4-day period. The average crawl space temperature for the last day was 54.2 °F. The rate of heat input to the electric heaters was adjusted so that a continuous

operation of the system maintained an average of 74.6 °F inside the house. The simulated party wall was maintained at 75 °F over its surface. The first 3 days of this test were provided in order to eliminate transient heat flows and insure near steady-state conditions for the fourth day. The constant rate of heat input to the house was 15,300 Btu·h<sup>-1</sup>.

From the values given in table 7 for the thermal transmittances and areas of the various surfaces, temperature differences and air infiltration rates given in appendix A, it is possible to determine a calculated heat loss for the house. Neglecting the heat loss due to air infiltration, the calculated value involving conduction heat flow is 10,606 Btu h<sup>-1</sup>. If the remaining heat loss, 4724 Btu h<sup>-1</sup>, is considered to be due to air

infiltration, the air change rate is calculated to be .61 air changes per hour. Air infiltration tests show that for a temperature difference,  $74.6 - 27.9 = 46.7$  °F, the rate is about 0.63 air changes per hour, which gives a heat loss of  $4893 \text{ Btu h}^{-1}$ . The unaccounted loss is  $169 \text{ Btu h}^{-1}$  or 1.1 percent of the total heat loss.

Using the thermal transmittance values given in table 7, heat fluxes were calculated and compared to heat flux rates measured by heat flow meters. Values are given in the following table.

Building surface		Heat flow ( $\text{Btu h}^{-1} \text{ft}^{-2}$ )	
		Calculated	Measured
Ceiling	Insulation	2.08	2.39
	joist	5.15	4.13
Walls	Insulation	2.96	2.97
	stud	6.44	4.47
Carpet	Insulation	.65	1.24
Floor	joist	1.69	1.26

The agreement between measured and calculated values is good for heat flow through the glass fiber insulation in walls and ceiling. The measured values are consistently lower for heat flow across wood through members. This may be due in part to thermal resistance of the heat flow meter being placed in series with the relatively high conductive wood through members. In addition, the heat flow pattern spreads upon entering and leaving a through member. This two dimensional effect causes the heat flow meter to see only a portion of total heat flow through the through member, and thus indicates a lower heat flow rate. For heat flow through the carpeted floor with insulation, the calculated value was about one-half the value measured by the heat flow meter. This is believed to be due to the uncertainty of measurement using heat flow meters at relatively low heat flux rates. Multiplying the calculated values by their respective areas (table 7) and summing gives a value of  $6994 \text{ Btu h}^{-1}$  and the corresponding measured summation is  $6868 \text{ Btu h}^{-1}$  for the opaque areas of the house. Thus, the use of heat flow meters on all opaque areas of the house when taken together as a whole yielded a reasonably good comparison.

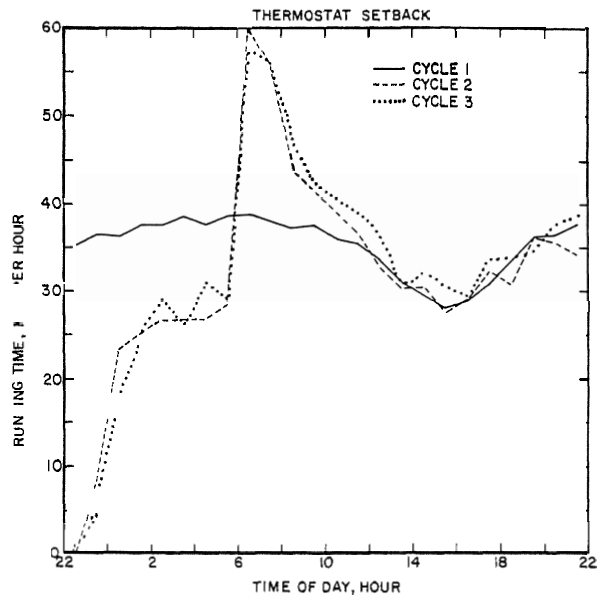

FIGURE 61. Furnace system on time for test 3.

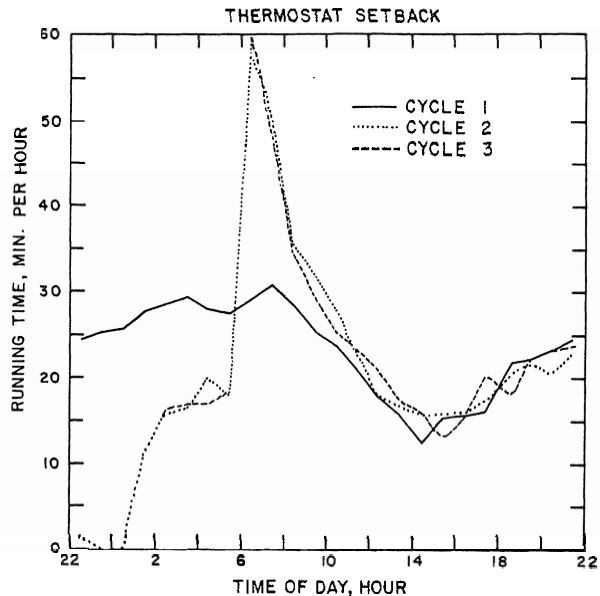

FIGURE 62. Furnace system on time for test 5.

The average temperature drop across the inside and outside surfaces of the double pane windows was  $15.6$  °F. The conductance of the double pane window calculated from eq (3) gives  $1.42 \text{ Btu h}^{-1} \text{ft}^{-2} \text{F}^{-1}$  and a heat flux of  $22.15 \text{ Btu h}^{-1} \text{ft}^{-2}$ . Based on this value, the thermal transmittance for windows,  $U = 22.15/46.7 = 0.47 \text{ Btu h}^{-1} \text{ft}^{-2} \text{F}^{-1}$ . The value used in previous calculations was  $U = 0.46 \text{ Btu h}^{-1} \text{ft}^{-2} \text{F}^{-1}$ .

### 6.8. Temperature Distribution During Winter Tests

Density differences cause warm air to rise in a room so that in the absence of other driving forces there will be a temperature gradient from floor to ceiling in a room. In the test house studied in this report the warm air outlets were located in the walls near the ceiling level, except in upstairs bedroom 4 where the outlet was located in a wall close to the floor level.

During operation of the system for winter heating, warm air was introduced into all but one room at the ceiling level. The warm air due to its decreased density tended to remain at the ceiling level giving fairly large temperature differences from floor to ceiling. This is shown in figure 63 where temperatures at various distances above the floor level are given as a function of time for the downstairs rooms during test 1. For this test the floor to ceiling temperature difference averaged 18 to 20 °F where the nighttime temperature in the kitchen was as low as 55 °F at the 3-in level. The vertical temperature difference in the occupied region from the 3-in to the 72-in level averaged 12 to 15 °F. Similar temperature gradients were found for all winter tests. For test 1, the upstairs bedrooms were able

to maintain small temperature gradients as shown in figure 64.

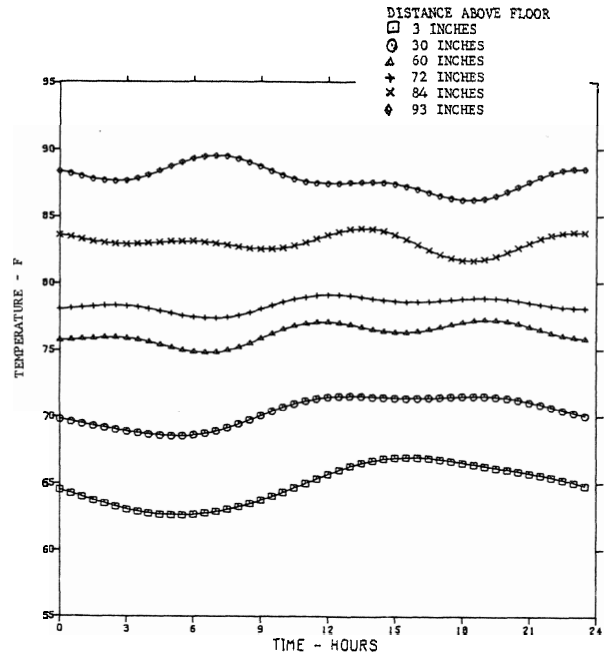

FIGURE 63b. (Family room).

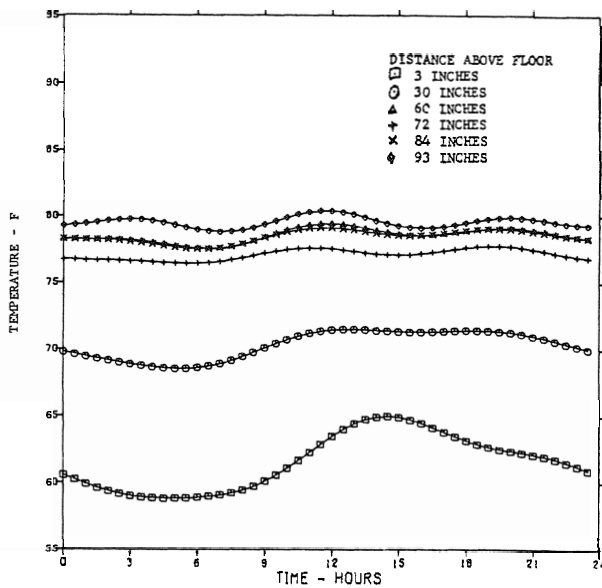

FIGURE 63a. Downstairs temperatures at various levels for test 1 (living room).

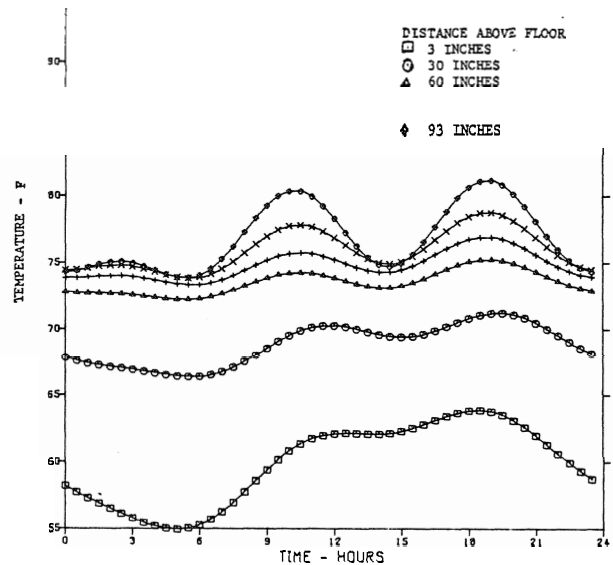

FIGURE 63c. (Kitchen).

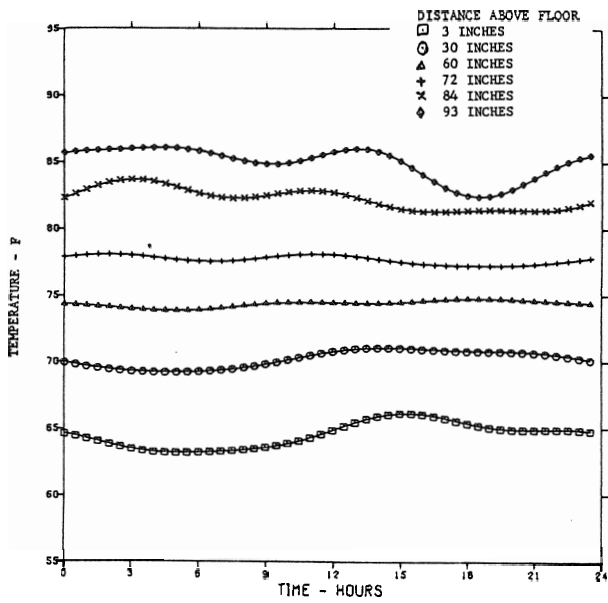

FIGURE 63d. (Bedroom 1).

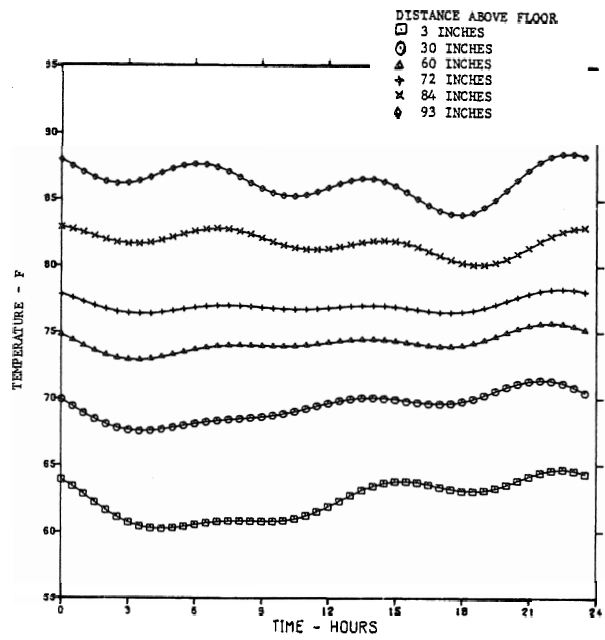

FIGURE 63f. (Bathroom 1).

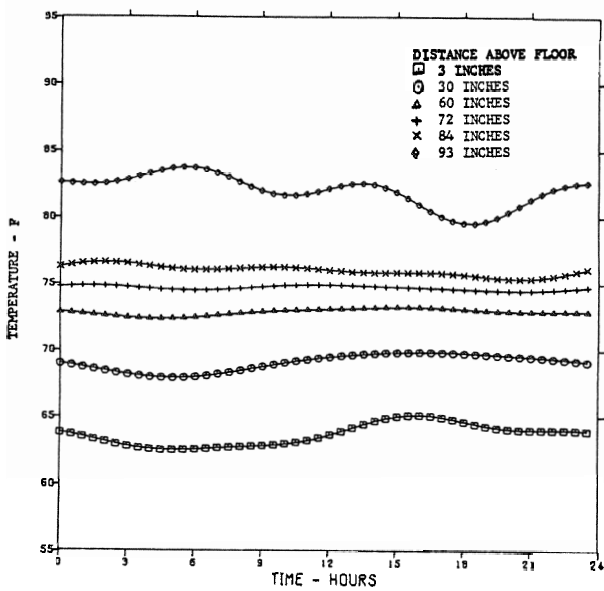

FIGURE 63e. (Bedroom 2).

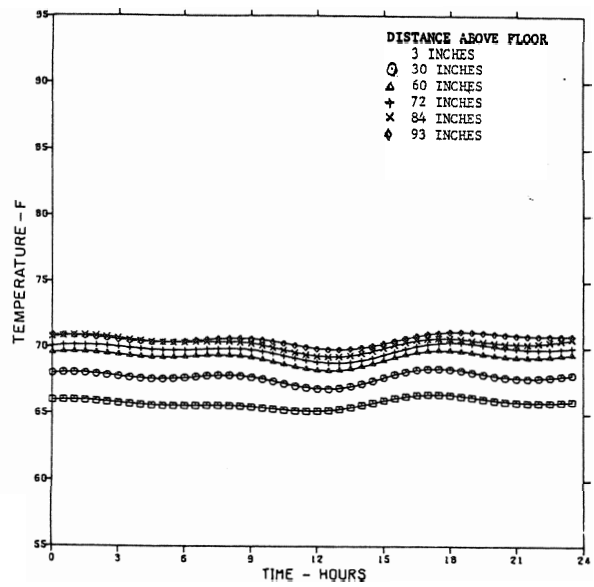

FIGURE 64a. Upstairs temperatures at various levels (Bedroom 3).

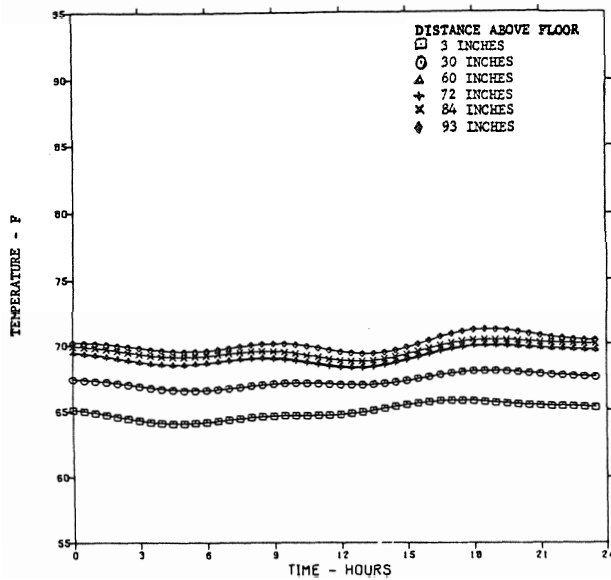

FIGURE 64b. (Bedroom 4).

During test 2 a temperature scan was made during an operation of the furnace system to determine the effect of heating operation on the vertical temperature difference. Figure 65 shows temperature profiles at the center of the kitchen for times corresponding to the start of system operation, 2 min after start-up, and 4 min after start-up. Four minutes of operation increased the floor-to-ceiling temperature difference from 15 1/2 to 22 1/2 °F.

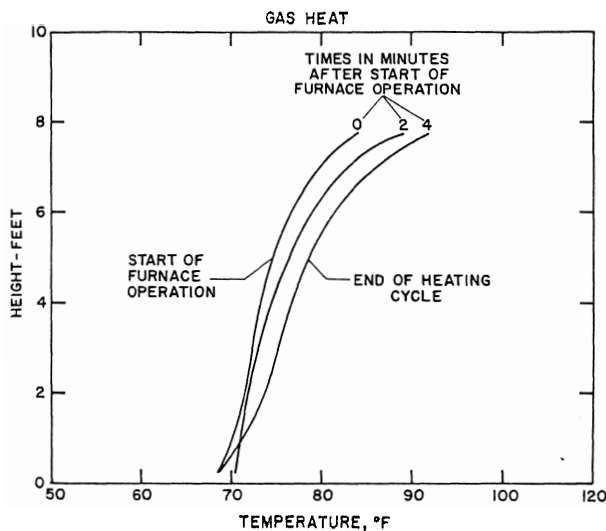

FIGURE 65. Vertical temperature distribution at center of kitchen during furnace operation for test 2.

The mean temperature difference across the upstairs and downstairs occupied zones of the test house for test 2 (gas heat) are compared with the corresponding values of test 1 (electric heat). The occupied zone is defined as the indoor space 3 to 72 in above the floor and 2 ft from the exterior walls. The mean temperature difference across the upstairs occupied zone was calculated by taking the arithmetic average of the temperature differences between the 72- and 3-in levels at the center of the two upstairs bedrooms. The mean temperature difference across the downstairs occupied zone was similarly calculated. The outside air temperature cycles for these tests were practically identical, although there was a tendency of the outside air temperatures for test 2 (gas heat) to be approximately 2 °F higher than for test 1 (electric heat).

Figure 66 is a plot of the mean temperature differences across the upstairs occupied zone (lower set of curves) and the downstairs occupied zone (upper set of curves) for these tests. The outside air temperature cycle for test 2 (gas heat) is also included on this graph. The dips in the mean temperature difference curves for the downstairs occupied zone should be attributed to a reduction in furnace operation and air infiltration during warmer periods of the day. The

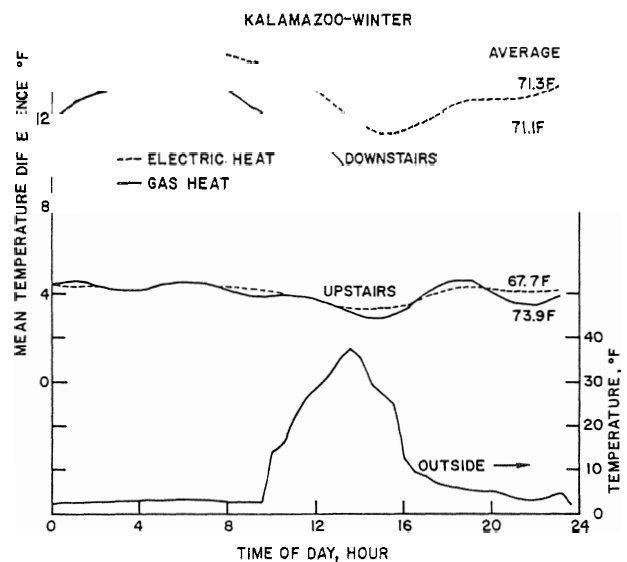

FIGURE 66. Mean temperature difference of occupied zones for tests 1 (electric) and 2 (gas).

percentage of furnace operation for these tests is plotted versus time in figure 67. Comparing the upstairs temperature difference curves, the temperature difference curve for test 1 (electric heat) is consistently higher than the corresponding curve for test 2 (gas heat). For the electric heat test the rate of heat output of the system was intentionally made lower, so that during periods of cold outside temperature, the heating system would operate a greater percentage of the time. The greater amount of operating time for test 1 (electric heat) causes the temperature difference across the downstairs occupied zone to be consistently larger. The temperature difference across the upstairs occupied zone for both gas and electric heat was very nearly a constant value of 4 °F. The dips in these curves during periods of warm outside temperature was much less pronounced than the corresponding curves for the downstairs. For these tests the upstairs supply register dampers were closed in order to achieve a balanced temperature distribution throughout the test house.

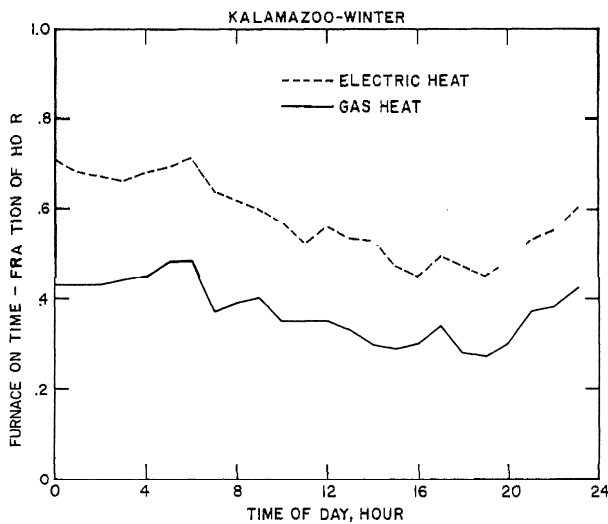

FIGURE 67. Heating system on-time for test 1 (electric) and test 2 (gas).

## 6.9. Mean Radiant Temperature

One of the factors affecting human comfort is the radiation exchange between a person and his surroundings. The radiation environment is

usually expressed in terms of its mean radiant temperature (MRT) which is defined as the temperature of a uniform black enclosure in which a solid body or occupant would exchange the same amount of radiant energy as in the existing nonuniform environment. At thermal equilibrium the heat gained or lost by radiation to a Vernon globe thermometer must equal the heat lost or gained by convection. In terms of heat transfer relationships:

$$T_w^4 = T_g^4 + 0.103 \times 10^9 \sqrt{W} (T_g - T_a) \quad (7)$$

where

- $T_w$  = mean radiant temperature, °F abs  
(black body equivalent)
- $T_g$  = globe temperature, °F abs
- $W$  = air velocity, fpm
- $T_a$  = globe, ambient air temperature, °F abs

Under the dynamic test conditions of this study and the intermittent operation of the furnace and air conditioning system, the recorded instantaneous ambient air temperatures possessed random fluctuations. The air temperature which should be used in the above equation is the average temperature for a time period. This may be achieved by applying a harmonic analysis to the data for the air temperature adjacent to a globe thermometer and using only the first four harmonics of the resulting series. Air velocities in the vicinity of the globe thermometers were measured and found to be in the range of 7 to 10 fpm. An air velocity of 8 fpm was used in the mean radiant temperature analysis.

The daily variation of the MRT in the living room, family room, and the kitchen for winter heating test 2 is plotted in figure 68. The peak MRT values occurring at 2000 h in the living room and family room are due to the delayed effect of the maximum outdoor temperature being propagated through the wall and roof surfaces. The peaks at 0930 and 2000 h in the kitchen are attributed to cooking activities. The operation of the oven and burners increases room surface temperatures through radiation exchange with these surface temperatures and through an increase in the room air temperature which

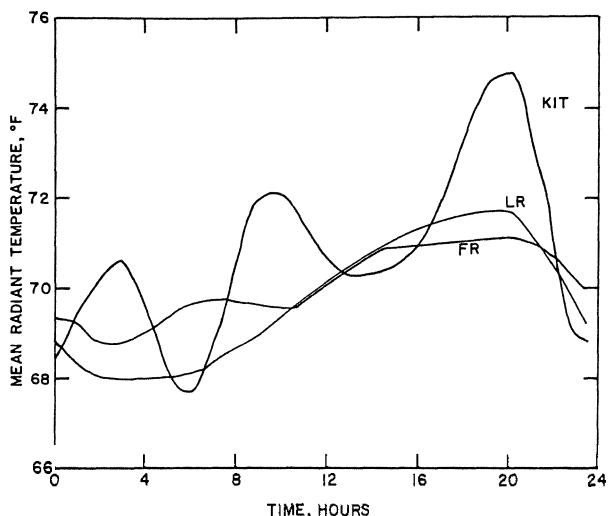

FIGURE 68. Calculated MRT in the living room, family room and kitchen for test 2.

transfer heat by convection to these surfaces. The daily variation in the MRT in the four bedrooms is plotted in figure 69.

The difference between the MRT and the ambient air temperatures is plotted in figure 70. The ambient air temperature used was the temperature measured at the 30-in level, since this is the level at which the globe thermometers were placed. Notice that there was a tendency for the MRT to be higher than the ambient temperature in the downstairs rooms, whereas a reversed behavior was observed in the upstairs rooms.

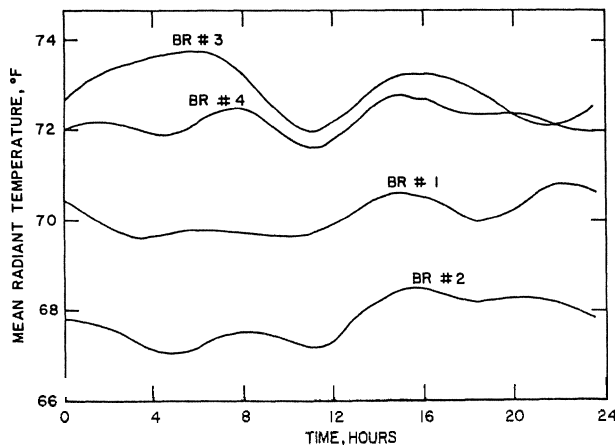

FIGURE 69. Calculated MRT in bedrooms for test 2.

Referring to the temperature distribution curves given in figures 63 and 64, inside air temperatures as high as 87 were measured at the 84-in level. This high-temperature air warmed the ceiling surfaces and caused the MRT for the downstairs rooms to be higher than the observed ambient temperatures.

### 6.10. Humidity Analysis

For the winter conditions the indoor relative humidity was maintained at very nearly a constant value by the humidifier attached to the furnace system. The humidifier had a limit control which monitored the relative humidity of the air

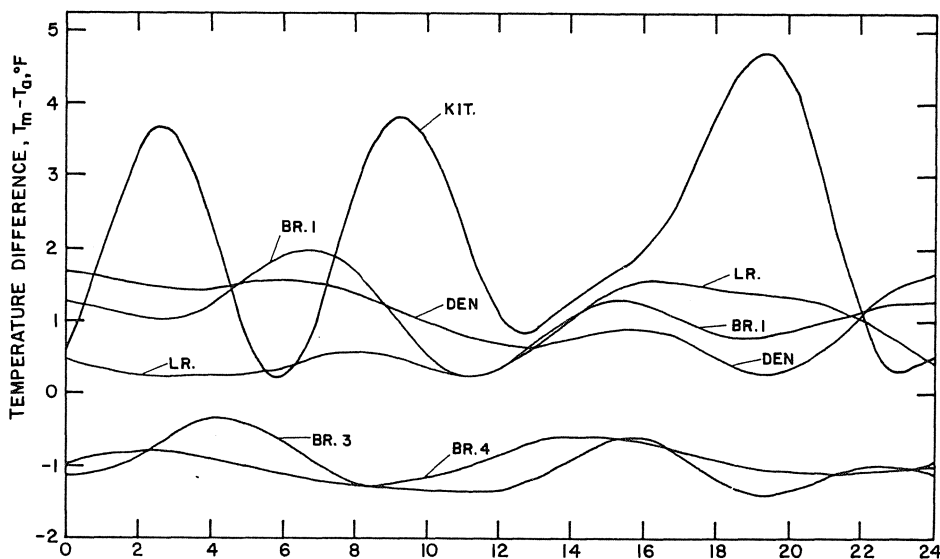

FIGURE 70. Difference between MRT and adjacent air temperatures for test 2.

in the return of the furnace system. When the relative humidity was below some prescribed set point, this limit control caused the humidifier to add moisture to the house during the operation of the furnace system. The relative humidities in the living room, kitchen, master bedroom, and downstairs bathroom for the Kalamazoo winter test with electric heat (test 1) are plotted versus time in figure 71. The two sharp peaks at 2100 and 2200 h in the bathroom are due to a bath and shower, respectively. Notice that the relative humidity is slightly higher in the upstairs master bedroom compared to the downstairs rooms. There is a tendency for warm air to rise in the house, causing air exfiltration from the window cracks and vent opening of the second floor. This upward warm air movement transports water vapor, causing the relative humidity to be higher in the upstairs rooms of the house.

The rate of air infiltration and the rate of water consumption by the humidifier is plotted versus time in figure 72. The rate of air infiltration was calculated from the linear relationship between the rate of air infiltration and the difference in temperature between indoor and outdoor air (see app. A). Notice that there is a tendency for the rate of water consumption by the humidifier to decline during periods of low infiltration.

The exfiltration of indoor air transports water vapor from the house. The daily mass,  $M$ , of water lost through exfiltration may be calculated by the relation:

$$M = \int_0^{24} I \rho V (\omega_i - \omega_o) dt \quad (8)$$

where

- $I$  = rate of air infiltration, air changes per h
- $\rho$  = density of air,  $\text{lbm ft}^{-3}$
- $V$  = inside volume of house,  $\text{ft}^3$
- $\omega_i$  = indoor humidity ratio,  $\text{lbm water vapor per lbm of dry air}$
- $\omega_o$  = outdoor humidity ratio,  $\text{lbm water vapor per lbm of dry air}$
- $t$  = time, h

During Kalamazoo winter test with electric heat (test 4), the outdoor humidity ratio was

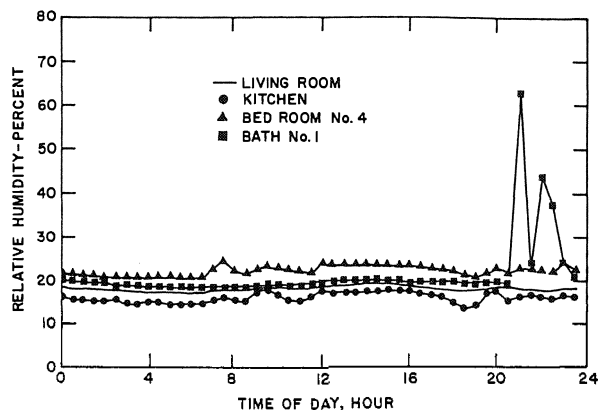

FIGURE 71. Measured daily variations of relative humidity for test 1.

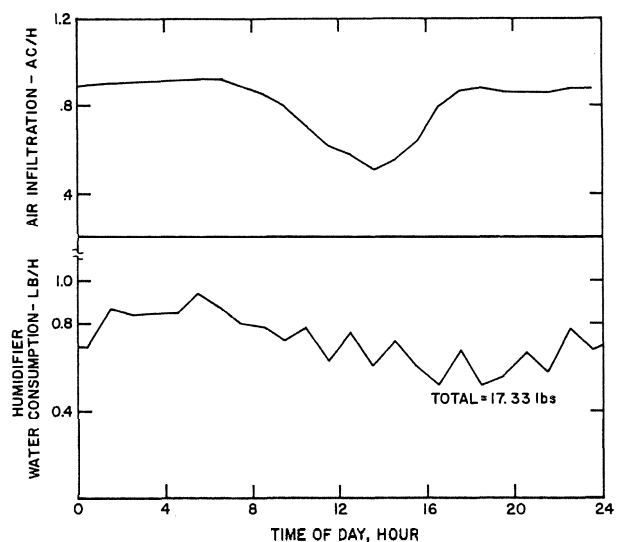

FIGURE 72. Daily variation in the rate of air infiltration and the rate of humidifier water consumption for test 1.

maintained at approximately a constant value of 0.0006. This value corresponds to a dew point of  $-5$  °F. The indoor relative humidity was maintained at an average value of 20.5 percent at an indoor temperature of 73 °F. This corresponds to an indoor humidity ratio of 0.0035. Substituting the indoor and outdoor humidity ratios, the volume of the house ( $V = 9240 \text{ ft}^3$ ), the density of air at room temperature ( $\rho = 0.074 \text{ lbm/ft}^3$ ), and the rate of air infiltration  $I$  as a function of time, the above expression may be integrated over a 24-h period to give the daily mass of water lost from the house



due to air exfiltration. This integration was performed giving a daily loss of water of 29.2 lbm. The net water supplied by the humidifier over this time period was 17.3 lbm. The difference between the water loss by air exfiltration and the water supplied by the humidifier, 11.9 lbm, must be equal to the water given off by occupant-related activities relating to water usage such as baths, showers, dishwasher operation, etc. Since the net daily hot water supply was 901 lbm, water given off by occupant-related activities was slightly greater than one percent of the net daily hot water consumption.

For the Kalamazoo winter test with gas heat (test 2) the outdoor humidity ratio was maintained at an average value of 0.0008. The indoor humidity ratio was maintained at a constant value of 0.0042 corresponding to a relative humidity of 22.7 percent at an indoor temperature of 74 °F. The water lost by exfiltration calculated by eq (8) was 34.2 lbm. The water supplied by the humidifier during a 24-h period was 17.7 lbm. The difference in these values (16.5 lbm) is equal to the water introduced by occupancy-related activities relating to hot water usage. This value, 16.5, seems somewhat high, but studies [6] have shown that the average daily production of water vapor for a family of four may be as much as 25 lbm excluding such appliances as humidifiers, and automatic washers and dryers.

The above moisture balances do not take into account window condensation. The effect of including window condensation in the analysis would be to increase the estimated moisture release from occupancy-related activities.

For the Kalamazoo winter tests, visual observations were made of the visible condensation, frost and ice formation on windows and frames. Ice formations were found on the lower surfaces of aluminum frames for all windows of the first floor except in the kitchen. In some cases the ice extended a short distance up the frame becoming condensation on the frame halfway up the window. There was no condensation or ice formation on the upper half of the frames. Depending upon the outside temperature there was frost or condensation on the glass of the window. These formations occurred in patches, usually in corners, and predominately in the lower half of the window.

## 7. Conclusions

On a full-scale four-bedroom townhouse a comparison was made between measured values of energy consumption and values predicted using the NBS Load Determination Computer Program. The test house was placed in an environmental chamber and exposed to various dynamic temperature cycles to simulate winter, fall, and summer conditions. During the tests the activities and occupancy of a six-member family were simulated. The rates of heating and cooling input energy were measured, and these values were compared to corresponding predicted values of the NBSLD computer program. For the computer validation tests, NBSLD predicted maximum heating and cooling consumption rates within a difference of 9.2 percent from the measured values. The average difference for predicting maximum energy input rates was 2.9 percent. In predicting daily energy requirements, the maximum difference was 8.2 percent, whereas the average difference was 4.5 percent. Thus, the NBSLD computer program may be used with confidence for predicting peak heating and cooling loads and energy requirements for a domestic dwelling.

Separate tests were performed to investigate the energy savings achieved by night temperature setback. An 8-h 10 °F night temperature setback produced an 11 percent savings in energy for a design day at Macon, Ga., and a 9 percent savings for a design day at Kalamazoo, Mich.

Experimental measurements under controlled laboratory conditions corroborated the earlier finding that the rate of air infiltration for a building is linearly related to the difference in temperature between the inside and outside.

And finally, it was found that the practice of placing the furnace warm air outlets at the ceiling level caused large temperature gradients to exist in the living space of a house. Temperature gradients as high as 25 °F were observed for the most severe winter condition.

## 8. Nomenclature and Conversion Factors

- A surface area, ft<sup>2</sup>
- c tracer gas concentration, parts per million

*C* thermal conductance, Btu h<sup>-1</sup> F<sup>-1</sup>  
*C<sub>p</sub>* specific heat of air, Btu lbm<sup>-1</sup> F<sup>-1</sup>  
*CR* common ratio, dimensionless  
*E<sub>c</sub>* rate of cooling energy input, Btu h<sup>-1</sup>  
*E<sub>h</sub>* rate of heating energy input, Btu h<sup>-1</sup>  
*I* rate of air infiltration, h<sup>-1</sup>  
*M* mass of water lost by exfiltration, lbm  
*N* number of significant terms of series  
*P* number of surfaces, dimensionless  
*q* rate of heat transfer, Btu h<sup>-1</sup>  
*Q* total amount of tracer gas in house, lbm  
*t* time, h  
*T* temperature, F  
*TI* temperature history of inside surface, F  
*TO* temperature history of outside surface, F  
*U* air-to-air thermal transmittance,  
 Btu h<sup>-1</sup> F<sup>-1</sup> ft<sup>-2</sup>  
*V* volume of house, ft<sup>3</sup>  
*Ṁ* air movement rate, ft<sup>3</sup> h<sup>-1</sup>  
*W* air velocity, ft h<sup>-1</sup>  
*X* response factor at inside surface,  
 Btu h<sup>-1</sup> ft<sup>-2</sup> F<sup>-1</sup>  
*Y* response factor at outside surface,  
 Btu h<sup>-1</sup> ft<sup>-2</sup> F<sup>-1</sup>

#### Greek Symbols

$\delta$  standard deviation, dimensionless  
 $\eta$  furnace efficiency, dimensionless  
 $\rho$  density of air, lbm ft<sup>-3</sup>  
 $\phi$  coefficient of performance, dimensionless  
 $\omega$  humidity ratio

#### Subscripts and Superscripts

*a* air space or air property  
*b* electric lighting  
*c* crawl space air  
*d* door  
*e* equipment  
*g* globe thermometer  
 HWH hot water heater  
*i* inside air or inside surface  
*j* time index of summation  
*l* latent  
*L* total heat loss  
*m* surface index of summation  
*n* surface index of summation or current  
 time interval index  
*o* outside air or outside surface or occupancy  
*P* number of surfaces  
*r* return air or surface index of summation  
*s* supply air  
*w* mean radiant property or window

#### Conversion factors to metric (S.I.) units

Physical quantity	Symbol	To convert from	To	Multiply by
Length	x	ft <sup>2</sup>	meter	3.04* × 10 <sup>-1</sup>
Area		ft <sup>3</sup>	m <sup>3</sup>	9.290 × 10 <sup>-2</sup>
Volume		ft <sup>3</sup>	m	2.832 × 10 <sup>-2</sup>
Temperature		Fahrenheit	Celsius	$t_c = (t_f - 32)/1.8$
Temperature difference		Fahrenheit	Kelvin	$K = (\Delta T_f)/1.8$
Mass		lbm	kg	4.536 × 10 <sup>-1</sup>
Density	$\rho$	lbm ft <sup>3</sup>	kg/m <sup>3</sup>	1.602 × 10 <sup>1</sup>
Thermal conductivity	<i>k</i>	Btu h ft <sup>2</sup> (F in)	W/mk	1.442 × 10 <sup>-1</sup>
U-value	<i>U</i>	Btu h ft <sup>2</sup> F	W/m <sup>2</sup> K	5.678
Thermal resistance	<i>R</i>	F Btu h ft <sup>2</sup>	1.761 × 10 <sup>-1</sup>	
Heat flow	<i>q/A</i>	Btu h ft <sup>2</sup>	W/m <sup>2</sup>	3.155
Heat flow		Btu h	W	2.931 × 10 <sup>-1</sup>
Heat flow		ton (of refrigeration)	W	3.517 × 10 <sup>3</sup>
Flow		cfm	m <sup>3</sup> /s	4.719 × 10 <sup>-4</sup>
Velocity		fpm	m/s	5.08 <sup>0</sup> × 10 <sup>-3</sup>
Cooling efficiency		Btu h kW		2.931 × 10 <sup>-4</sup>
Specific heat		Btu lbm	j/kg.K	4.187 × 10 <sup>3</sup>

\*Exact value; others are rounded to fourth place.

The authors wish to thank D. R. Showalter, J. D. Allen, and J. W. Grimes for their technical assistance in the installation of the instrumentation and day-to-day operation of the experiments. The very helpful suggestions and comments made during review of this paper by P. R. Achenbach are gratefully acknowledged.

### 9. References

- [1] Kusuda, T., National Bureau of Standards Heating and Cooling Load Determination Program, Building Science Series in progress.
- [2] Peavy, B. A., Powell, F. J., and Burch, D. M., Dynamic thermal performance of an experimental masonry building, Nat. Bur. Stand. (U.S.), Bldg. Sci. Ser. 45, 103 pages (July 1973).
- [3] Kusuda, T., Thermal response factors for multi-layer structures of various heat conduction systems, ASHRAE Transactions, pp. 250-269, Part I, 1969.
- [4] Bahnfleth, D. R., Moseley, T. T., and Harris, W. S., Measurement of Infiltration in Two Residences, Part I: Technique and Measured Infiltration, Part II: Comparison of Variables Affecting Infiltration, ASHRAE Transactions, Vol. 63, pp. 439-452, 1957.
- [5] Procedures for Determining Heating and Cooling Loads for Computerized Energy Calculations, The Task Group on Energy Requirements for Heating and Cooling, ASHRAE, 345 East 47th Street, New York, 1971.
- [6] Hite, S. C. and Dray, Research in Home Humidity Control, Purdue University Engineering Experiment Station Research Series No. 106, November 1948.

## Appendix A

### Air Infiltration Measurements on the Four-Bedroom Townhouse

#### 1. Introduction

Air leakage is one of the important paths by which a house gains or loses heat. To determine the rate of exchange between the house and its surroundings the rate of disappearance of a tracer gas was measured. This is a common method of measuring infiltration rates, and a number of gases have been used for the purpose. These include helium [1, 2],<sup>1</sup> and ethane [3] as well as other gases. More recently sulfur hexafluoride [4] has been used for the purpose, and this gas was used in the present measurements because it is relatively nontoxic, nonflammable, and may be conveniently measured in concentrations of the order of 5 to 20 ppb.

#### 2. Theory

The principle of the tracer method for measuring air exchange may be outlined briefly by considering the average rate,  $v_o$ , at which air leaks into a house, and which must equal the average rate at which air leaks out unless there is some steady buildup or decrease in pressure. The rate of change in the total amount of tracer in the house may be expressed by the relationship,

$$\frac{dQ}{dt} = (C_o - C_i) v_o, \quad (\text{A-1})$$

where  $Q$  is the total amount of tracer in the house at time  $t$ ,  $C_o$ , and  $C_i$  are concentrations of tracer in the outside and inside air respectively,  $v_o$  is the volume rate at which air enters and leaves the

house. If  $V$  is the total volume of the house, equation (A-1) becomes

$$\frac{1}{V} \frac{dQ}{dt} = \frac{dc_i}{dt} = (C_o - C_i) \frac{v_o}{V}, \quad (\text{A-2})$$

where  $v_o/V$  is the infiltration rate expressed in air changes per unit time. If the outside concentration of tracer is small enough to be neglected, eq (A-2) reduces to

$$\frac{dC_i}{dt} = -C_i \frac{v_o}{V} \quad (\text{A-3})$$

which in integrated form becomes

$$C_i = C_{ioe} - \frac{v_o t}{V}$$

or

$$\log_e \left( \frac{C_i}{C_{io}} \right) = 2.303 \log_{10} \left( \frac{C_i}{C_{io}} \right) = - \frac{v_o}{V} t, \quad (\text{A-4})$$

where  $C_{io}$  is the concentration of tracer at time  $t = 0$ . Thus if  $\log C_i/C_{io}$  is plotted against time the idealized relationship calls for a straight line of slope  $-v_o/2.303V$ . Since the air exchange rate,  $I$ , is usually expressed in air changes per hour while flow rate,  $v_o$ , is measured in cfm,

$$I = \frac{60 v_o}{V} = -2.303 \times 60 \times \text{slope}. \quad (\text{A-5})$$

One of the tacit assumptions of this derivation is that air leaving the house has the same average tracer concentration as the air in the house. Also, it is assumed that sampling is representative. Both of these assumptions are approximations.

<sup>1</sup>Figures in brackets indicate the literature references given at the end of this appendix.

### 3. Measurement Techniques<sup>2</sup>

Sulfur hexafluoride (SF<sub>6</sub>) concentrations were measured with a Panatek Model 2000 leak detector operated in the chromatographic mode. In this mode, oxygen, which is also an electron capturing gas, is separated from SF<sub>6</sub> and the tracer is measured separately by means of the detector. If  $I_0$  is the standing current with pure carrier gas and  $I$  the current when a small amount of SF<sub>6</sub> is present, the response is treated as logarithmic. That is,

$$\log \frac{I}{I_0} = -kC \quad (\text{A-6})$$

where  $C$  is the concentration of tracer, and  $k$  is an arbitrary constant. In the chromatographic mode,  $I_0$  is a more or less steady standing current while  $I$  is the trough of a deflection. To accommodate for drift in the response of the detector with time and to minimize ballistic errors the instrument was usually calibrated three or four times during the course of each air exchange measurement with air containing 13.8 ppb SF<sub>6</sub>. Tracer concentrations in the house were usually in the range of  $13.8 \pm 5$  ppb.

Air samples were taken at recorded times and analyzed for SF<sub>6</sub>. Three different methods of sampling were compared. In method 1, samples were collected manually with a hand pump and a balloon, going from room to room in a timed sequence. The upstairs and downstairs were analyzed separately. In method 2, samples were collected through a sampling network consisting of 16 polyethylene tubes (6 mm i.d.) of identical length. One or more tubes extended to each of the rooms and hallways and all converged in a small pump with a capacity of 12 liters per min. In method 3, samples were drawn directly from the return air to the blower of the air distribution system. When infiltration measurements are made in occupied houses it is usually not possible to use methods 1 and 2, and method 3 is commonly used [3]. Data was analyzed separately for each method and also pooled for the three methods.

<sup>2</sup>Certain commercial materials and instruments are identified in this report in order to specify the experimental procedure adequately. Such identification does not imply recommendation or endorsement by the National Bureau of Standards, nor does it imply that the equipment is necessarily the best for the purpose.

### 4. Results and Discussion

A number of measurements were made under conditions of electric heat with an indoor temperature maintained at about 75 °F, and outside temperature maintained at different selected values. The results, showing infiltration as a function of the difference between inside and outside temperature are given in table A-1 for three methods of sampling.

TABLE A-1. Air exchange rate as a function of temperature difference between inside and outside

Temperature difference between inside and outside °F	Air changes per h		
	Method 1 (Hand sampling)	Method 2 (Network sampling)	Method 3 (Return air sampling)
52.3	0.61	0.59	0.61
52.1	.74	.74	.82
51.1	.68	.70	.70
49.3	.64	.72	.66
49.1	.55	.57	—
39.5	.46	.51	.60
36.8	.43	.55	.52
23.6	.45	.50	.50
23.6	.48	.28	.42
14.5	.17	—	.16
14.3	.29	.24	.33
9.6	.17	—	.22

The results show that when wind velocity is eliminated as a variable a strong correlation is obtained between infiltration rate and temperature difference,  $\Delta T$ . The temperature effect has also been observed by others [1,3,5]. The data in table A-1 also shows considerable scatter. A best fit straight line was obtained to correlate the data for each of the sampling methods. The equations and corresponding root mean square deviations for the three methods of sampling are given below:

$$\begin{aligned} \text{hand:} &= 0.113 + 0.0104\Delta T, \delta = 0.070 \\ \text{network:} &= 0.117 + 0.0108\Delta T, \delta = 0.072 \\ \text{return:} &= 0.124 + 0.0114\Delta T, \delta = 0.071 \end{aligned}$$

where  $\delta$  is the root mean square deviation. While there is considerable scatter in individual points,

overall agreement between the three methods of sampling is fairly close. For pooled data for all three sampling methods the equation is

$$I = 0.117 + 0.0108\Delta T, \delta = 0.074.$$

The pooled data and the corresponding least squares line are presented in figure A-1.

The effect of sealing doors and ducts was also measured, and the results are given in table A-2. The effect of sealing exhaust fan openings and doors was insufficient to outweigh the effect of inside/outside temperature difference. However, at a temperature difference near 50 °F data obtained with sealed openings averaged about 0.1 of an air change per hour less than that obtained with normal operation. It was noted by Elkins and

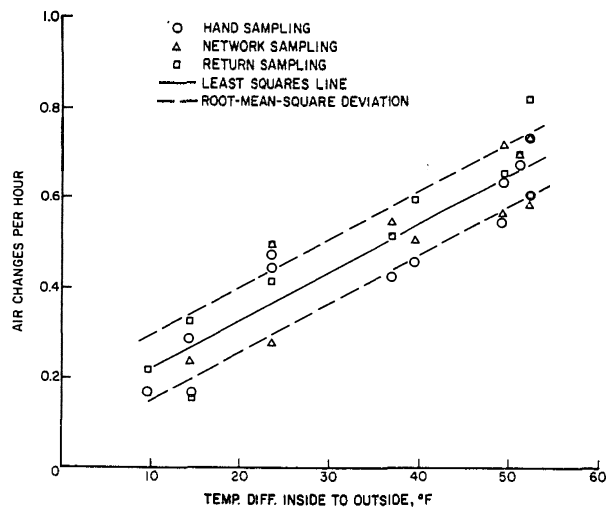

FIGURE A-1. Air exchange rate as a function of difference in temperature between inside and outside of townhouse.

TABLE A-2. Effect of sealing doors and vents in air infiltration rates

Conditions	Temperature difference between inside and outside °F	Air changes per hour		
		Method 1 (Hand sampling)	Method 2 (Network sampling)	Method 3 (Return air sampling)
Kitchen, bathroom and clothes dryer fan ducts sealed	52.4	.68	.48	.55
Kitchen, bathroom and clothes dryer fan ducts sealed	50.9	.58	.60	.58
Kitchen, bathroom, and clothes dryer fan ducts sealed. Doors also sealed.	49.5	.67	.48	.75

TABLE A-3. The effect of operating exhaust fans

Conditions	Temperature difference between inside and outside °F	Air changes per hour		
		Method 1 (Hand sampling)	Method 2 (Network sampling)	Method 3 (Return air sampling)
Kitchen fan on	52.6	0.77	0.88	0.88
Kitchen fan on	51.2	.98	1.16	1.10
Upstairs bathroom fan on	51.2	.85	.92	.89
Upstairs bathroom fan on	48.0	.88	.90	.87
Operate clothes dryer	51.6	.92	1.05	1.12

Wensman [3] that opening doors under conditions of very low wind velocity had little effect on air exchange rate. The results in tables A-1 and A-2 would tend to confirm this observation.

The infiltration rate during operating of the kitchen or bathroom exhaust fans or the clothes dryer are given in table A-3. They result in an increase in infiltration rate as might be expected. Data showing the effect of operating the main circulating fan is not shown. This fan was an integral part of the heating and cooling system and could not be turned off without turning off the furnace or air conditioner. When this was done and the house temperature allowed to drift, infiltration rates lower than those shown in table A-1 or figure A-1 were obtained. However, if the heating or cooling system were on, it made little difference whether the fan operated continuously or intermittently.

### 5. References

- [1] Bahnfleth, D. R., Moseley, T. T., and Harris, W. S., Measurement of infiltration in two residences, Part I: Technique and measured Infiltration, Part II: Comparison of variables affecting infiltration, Amer. Soc. Heating and Air Conditioning Eng. **63**, 439-452 (1957).
- [2] Coblenz, Carl W. and Achenbach, P. R., Design and performance of a portable infiltration meter, Amer. Soc. of Heating and Air Conditioning Eng. **63**, 477-482 (1957).
- [3] Elkins, R. H. and Wensman, C. E., Natural Ventilation of Modern Tightly Constructed Homes, paper presented at the American Gas Association of Gas Technology Conference on Natural Gas Research and Technology, Chicago, Ill., February 28-March 3, 1971.
- [4] Drivas, P. J., Simonds, P. G., and Shair, F. H., Experimental characterization of ventilation systems in buildings, Env. Sci. and Tech. **6** (7), 609-614 (1972).
- [5] Coblenz, C. W. and Achenbach, P. R., Field measurements of air infiltration in ten electrically-heated houses, Amer. Soc. Heating, Refrigerating and Air-Conditioning Eng. **69**, 358-365 (1963).

## Appendix B

### Interior Noise Levels in the Four-Bedroom Townhouse

Donald S. Blomquist\*

#### 1. Objective

The objective of these tests was to obtain information regarding interior noise levels due to the heating and air conditioning unit and two garbage disposal units.

#### 2. Test Procedure

All tests were performed in accordance with the procedures outlined in American National Standard Methods for Measurement of Sound Pressure Levels, S1.-13-1971.

Measurements of the noise levels due to mechanical equipment were carried out for comparison with the "noise criteria (NC) curves" given by Beranek (p. 564 in "Noise and Vibration Control", McGraw-Hill, 1971). The following locations and equipment were measured.

1. Living room: heater on.
2. Front bedroom, second floor: heater on.
3. Back bedroom, second floor: heater on.
4. Front bedroom, first floor: heater on.
4. Kitchen: heater on.
6. Kitchen: air conditioner on.
7. Kitchen: exhaust fan on.
8. Kitchen: two different garbage disposers on.

A total of six microphones, in a modified spherical array was used for all tests except the Garbage Disposal tests where one microphone was positioned over the sink at a height of 5 ft above the floor.

Temporal averages of sound pressure levels were obtained using a real time analyzer set to an integration time of 20 s. The digital output of the real time analyzer was connected to a mini-computer which switched the microphones,

averaged the signals from the different microphones, and combined the 1/3-octave band data into 1/1-octave bands for comparison with the NC-curves. Using this procedure, the statistical error due to temporal averaging is less than 1.2 dB (at a confidence level of 95%).

The uncertainty in measured sound pressure level, due to random and systematic uncertainties associated with the overall data acquisition system, is estimated (95% confidence level) to be less than  $\pm 1$  dB.

For all measurements the background noise (measured with the equipment off) was at least 10 dB below the operating noise with the equipment. Thus, the effect of any background noise on the measurement is less than 0.5 db.

For testing of garbage disposers unpopcorn was used as a load.

Extensive measurements were made on this housing system as part of Operation BREAKTHROUGH testing; these measurements include noise reduction and impact isolation of the interior walls and floors. The results of these tests are reported in NBSIR 73-191, "Acoustical Evaluation of a Single Family Attached Wood-Frame Modular Housing System Constructed on an Operation BREAKTHROUGH Prototype Site," 1973.

#### 3. Results

Results of the measurements are shown in figures B-1 through B-8. Figure B-1 shows the 1/1 octave band noise levels in the living room with the heating system operating. Figures B-2 through B-4 show the noise levels in the bedroom due to the heating system. Figures B-5 and B-6 are the results in the kitchen for the heating and air conditioning system, respectively. Figure B-7 shows the noise level due to the kitchen exhaust fan (without the HVAC system on). Figure B-8 shows the noise level (at a single position) for

\*Applied Acoustics Section, Mechanics Division, Institute for Basic Standards, National Bureau of Standards, Washington, D.C. 20234.



two models of garbage disposers produced by the same manufacturer, one being the most expensive and the second the least expensive.

These results are summarized in table B-1. In "A Guide to Airborne, Impact and Structure Borne Noise-Control in Multifamily Dwelling," U.S. Department of Housing and Urban Development, Washington, D.C., 1963, the following recommendations were made for interior noise:

1. for residential urban and suburban areas considered to have the average noise environment, interior noise environments should not exceed NC 25-30 characteristics.
2. for residential urban and suburban areas considered to be "noisy locations" interior noise environments should not exceed NC-35 characteristics.

TABLE B-1. The measured noise criteria characteristics of the housing system

Equipment	Room measured	NC
Heater on	living room	<55
Heater on	front bedroom	<40
Heater on	back bedroom	<45
Heater on	front bedroom (first floor)	<40
Heater on	kitchen	<55
Air conditioning on	kitchen	<55
Exhaust fan on	kitchen	<60
Inexpensive garbage disposal	kitchen	<65
Expensive garbage disposal	kitchen	<70

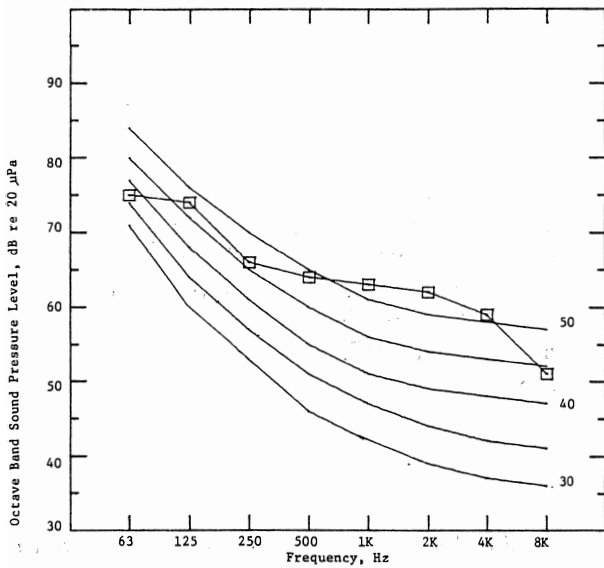

FIGURE B-1. The symbols show the octave band sound pressure levels in the living room with the heating system operating.

The numbered curves are "noise criteria curves,"

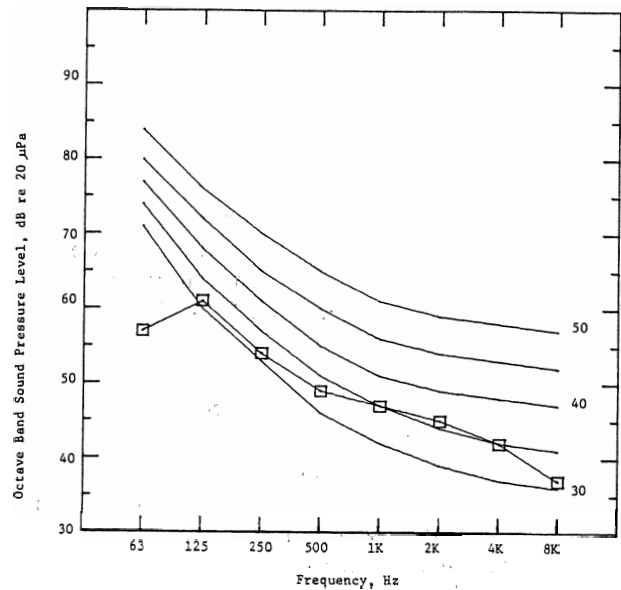
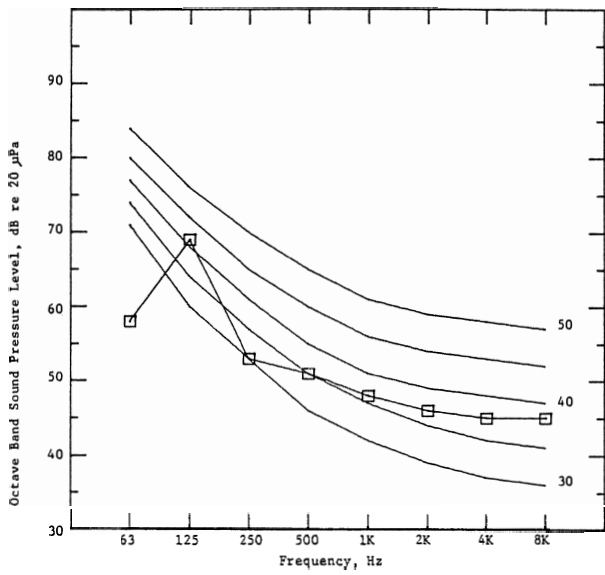

FIGURE B-2. The symbols show the octave band sound pressure levels in the front bedroom (second floor) with the heating system operating.

The numbered curves are "noise criteria curves,"



**FIGURE B-3.** The symbols show the octave band sound pressure levels in the back bedroom (second floor) with the heating system operating.

The numbered curves are "noise criteria curves,"

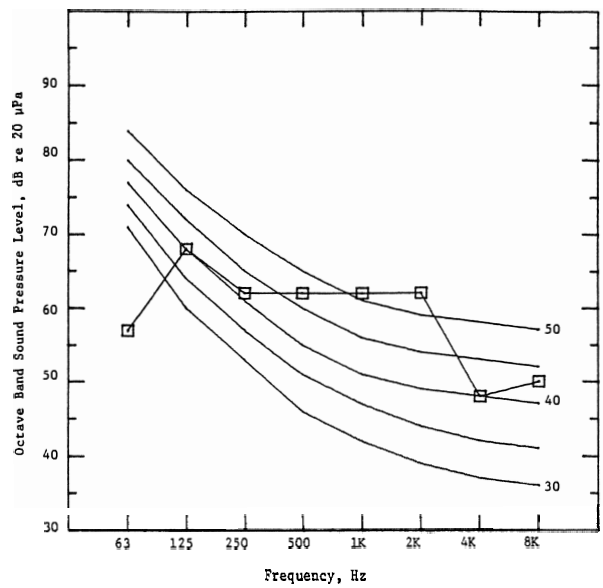

**FIGURE B-5.** The symbols show the octave band sound pressure levels in the kitchen with the heating system operating.

The numbered curves are "noise criteria curves."

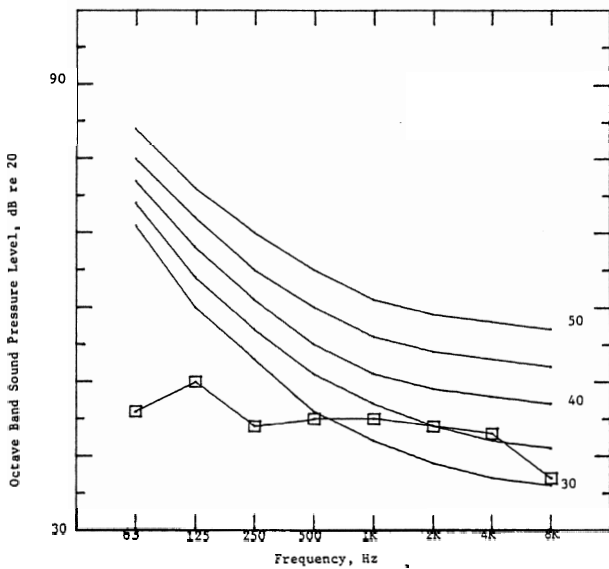

**FIGURE B-4.** The symbols show the octave band sound pressure levels in the front bedroom (first floor) with the heating system operating.

The numbered curves are "noise criteria curves."

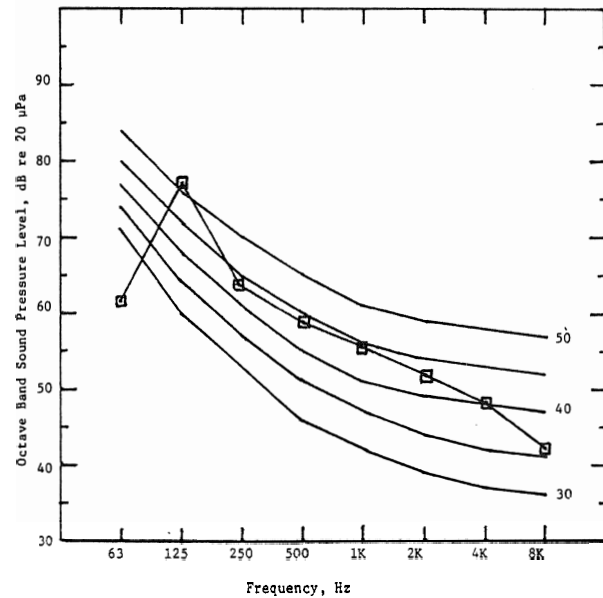

**FIGURE B-6.** The symbols show the octave band sound pressure levels in the kitchen with the air conditioning system operating.

The numbered curves are "noise criteria curves."

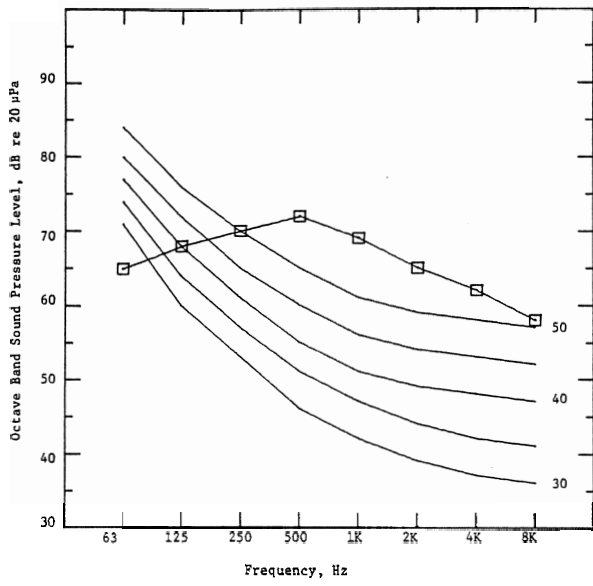

FIGURE B-7. The symbols show the octave band sound pressure levels in the kitchen with the exhaust fan operating.  
The numbered curves are "noise criteria curves."

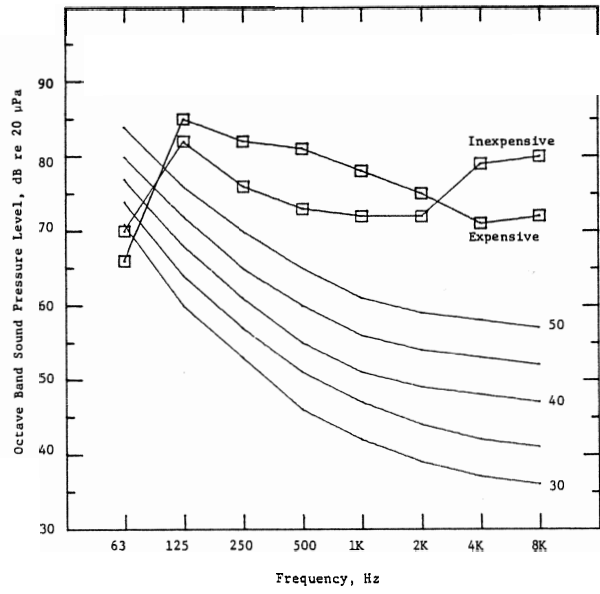

FIGURE B-8. The symbols show the octave band sound pressure levels in the kitchen with two different garbage disposers operating.  
The numbered curves are "noise criteria curves."

## Appendix C

### Mathematical Simulation for the Test House

The mathematic model used in the computer a building treats the building as a one-room enclosure. The various external wall, floor, and ceiling surfaces are treated as separate heat flow paths. The internal wall and ceiling partitions, the internal furnishings, and equipment are treated as plane slabs. Other assumptions made in the thermal analysis are:

1. The conduction heat transfer through components of the test house is one-dimensional. Heat conduction through thermal bridges such as wall stud is treated as a separate heat flow path with no lateral heat flow between adjacent components.
2. The heat-transfer coefficient for the inside and outside surfaces of the building is constant.
3. All building materials are homogeneous, having constant thermal and physical properties.
4. Heat and mass transfer of water in vapor or liquid form or the latent heats of condensation, freezing and evaporation is neglected, since the dew point temperature of the outside air was maintained below that for any temperature in a daily cycle.
5. The temperature distribution inside the house is uniform.

Using the above assumptions for simulating the thermal behavior of the test house may be derived. The Response Factor Method predicts the rate of heat conduction,  $q_n$ , at the current time interval,  $n$  into the surface of a solid as the sum of the response caused by a series of individual temperature pulses occurring at the bounding surface for preceding time intervals, or

$$q_n/A = \sum_{j=0}^N (X_j TI_{n-j} - Y_j TO_{n-j}) + (q_{n-1}/A) CR. \quad (C-1)$$

The values of the Response Factors,  $X_j$  and  $Y_j$ , and the number of significant series terms,  $N$

depend upon the type of structure and are precalculated in a separate routine in the computer program. The last term in the above equation represents the effect of the preceding rate of heat flow on the present value. The methodology dealing with the calculation of the Response Factors is discussed by Kusuda [3].

For a surface having negligible heat capacity such as windows and most doors of a building, the rate of heat conduction,  $q_n$  is given by the relation

$$q_n/A = U (Ti_n - TO_n) \quad (C-2)$$

The heat loss due to air infiltration is given by

$$q_n = \rho C_p VI (TI_n - TO_n). \quad (C-3)$$

The time dependent heat loss from a building is then equal to the sum of the rates of heat conduction through the surfaces having significant heat capacity, plus the sum of the heat flows through the windows and doors, plus the heat loss due to air infiltration. The net heat loss may be expressed by the relation

$$\begin{aligned} q_L = & \sum_{k=1}^P A_k [\sum_{j=0}^N (X_j^k TI_{n-j} - Y_j^k TO_{n-j}) + q_{n-1}^k CR^k] \\ & + U_d A_d (TI_n - TO_n) + U_w A_w (TI_n - TO_n) \\ & + \rho C_p VI (TI_n - TO_n). \end{aligned} \quad (C-4)$$

Notice that the heat flows through windows and doors have been lumped into separate terms in the above equation. If a building had different types of windows and/or doors, then each type would have to be handled by a separate term in this equation. In addition, when the first term applies to a floor surface over a crawl space, then the temperature  $TO$  would be the temperature of the crawl space air.

The indoor activities of a family such as hot water consumption, the operation of household appliances, etc., release a significant amount of heat and will contribute to the heating and cooling loads of a domestic dwelling. In particular, the heat release by occupant-related activities,  $q_p$ , over some time interval is given by

$$q_p = q_b + q_a + q_c + q_{HWH} \quad (C-5)$$

where

- $q_b$  = energy for electric lighting
- $q_a$  = heat given off by household appliances
- $q_c$  = sensible heat released by the occupants
- $q_{HWH}$  = heat release due to hot water consumption

The input energies supplied to the appliances with the exception of the hot water heater are considered to be instantaneous heat releases to the house. The heat release for the hot water heater is taken to be equal to the jacket skin loss without hot water consumption. When hot water is used, the additional heat release from activities such as baths, showers, etc., is taken into account by multiplying the jacket skin loss by a factor 1.833.

For the present study the activities of a six-member family were simulated, so that internal heat generation from occupant-related activities would be realistic. The sensible body heat given

off by the occupants were simulated with light bulbs. For the computer simulation it was possible to input to the computer program exact values for the energies for lighting,  $q_b$ , occupant body heat,  $q_c$ , and equipment,  $q_a$ . If this building simulation program were run on a house for which the schedule of indoor activities was not available, then it would be necessary to make reasonable estimates for these energies based on engineering judgment.

The heating load is equal to the difference between the calculated heat loss,  $q_L$  and the heat released by occupant-related activities,  $q_p$ . The energy required by a heating plant to overcome this heating load is equal to the heating load divided by the efficiency,  $\eta$  of the heating plant, or

$$E_H = (q_L - q_p)/\eta \quad (C-6)$$

In air conditioning applications the sensible cooling load,  $q_s$  is equal to the sum of the calculated heat gain (negative of the calculated heat loss,  $q_L$  and heat generated by occupant-related activities,  $q_p$ . The energy required by the cooling equipment to overcome this cooling load is equal to the sum of sensible cooling load,  $q_s$  and the latent cooling load,  $q_l$  divided by the coefficient of performance,  $\phi_c$  of the cooling equipment, or

$$E_c = (q_s + q_l)/\phi_c \quad (C-7)$$

U. S. DEPT. OF COMM. BIBLIOGRAPHIC DATA SHEET	1. PUBLICATION OR REPORT NO. NBS BSS - 57	2. Gov't Accession No.	3. Recipient's Accession No.
4. TITLE AND SUBTITLE Comparison of Measured and Computer-Predicted Thermal Performance of a Four Bedroom Wood-Frame Townhouse		5. Publication Date April 1975	6. Performing Organization Code
7. AUTHOR(S) B. A. Peavy, D. M. Burch, C. M. Hunt, and F. J. Powell		8. Performing Organ. Report No.	
9. PERFORMING ORGANIZATION NAME AND ADDRESS NATIONAL BUREAU OF STANDARDS DEPARTMENT OF COMMERCE WASHINGTON, D.C. 20234		10. Project/Task/Work Unit No.	
		11. Contract/Grant No.	
12. Sponsoring Organization Name and Complete Address (Street, City, State, ZIP) Same as 9. and Department of Housing and Urban Development 451 7th Street, S. W. Washington, D. C. 20410		13. Type of Report & Period Covered Final FY 74-75	
		14. Sponsoring Agency Code	
15. SUPPLEMENTARY NOTES Library of Congress Catalog Card Number: 74-20830			
16. ABSTRACT (A 200-word or less factual summary of most significant information. If document includes a significant bibliography or literature survey, mention it here.) Measurements of the dynamic heat transfer in a four bedroom townhouse were made under controlled conditions in a large environmental chamber to explore the validity of a computer program developed at NBS, labelled NBSLD, for predicting heating and cooling loads and inside air temperatures. This study was supported jointly by the Department of Housing and Urban Development and the National Bureau of Standards, and is a part of a broader research program supported by both agencies to improve performance test procedures and criteria for housing. The test house was a factory-produced four bedroom townhouse of modular design and of lightweight (wood) construction. Tests were performed with simulated outside summer, winter and fall diurnal temperature cycles. The inside temperature was maintained at about 75 °F. Also during the tests, the activities of a six-member family were simulated. The time-varying energy requirements were measured, and these values were compared with computer predicted values. For example, the disparity between predicted and measured daily heating energy requirements averaged 3.1% with a maximum departure of 4.9% for five tests. The computer program NBSLD was experimentally validated for predicting the peak heating and cooling loads and the energy requirements for the test house. The air leakage of the house was measured by a tracer gas technique over a range of outdoor conditions, and algorithms were developed to account for its effect on heating loads and energy requirements. (Continued)			
17. KEY WORDS (six to twelve entries; alphabetical order; capitalize only the first letter of the first key word unless a proper name; separated by semicolons) air leakage measurement; building heat transfer; computer programs; dynamic thermal performance; heat flow analysis; heating and cooling loads; temperature predictions; thermal analysis; thermostat setback; transient heat flows			
18. AVAILABILITY <input checked="" type="checkbox"/> Unlimited <input type="checkbox"/> For Official Distribution. Do Not Release to NTIS <input checked="" type="checkbox"/> Order From Sup. of Doc., U.S. Government Printing Office Washington, D.C. 20402, SD Cat. No. C13:29/2:57 <input type="checkbox"/> Order From National Technical Information Service (NTIS) Springfield, Virginia 22151		19. SECURITY CLASS (THIS REPORT) UNCLASSIFIED	21. NO. OF PAGES 62
		20. SECURITY CLASS (THIS PAGE) UNCLASSIFIED	22. Price \$1.20

Separate tests were also performed to investigate the energy savings achieved by night temperature setback. An 8-h 9 °F setback from 75 °F produced an 11 percent diurnal savings in energy for an average nighttime temperature of 20 °F and a 9 percent savings in energy was achieved for the same setback when the average nighttime temperature was 2 °F.

